



(11) **EP 1 050 264 B1**

(12) **EUROPEAN PATENT SPECIFICATION**

(45) Date of publication and mention of the grant of the patent:  
**12.03.2008 Bulletin 2008/11**

(51) Int Cl.:  
**A61B 5/00** <sup>(2006.01)</sup> **A61B 5/03** <sup>(2006.01)</sup>  
**A61M 27/00** <sup>(2006.01)</sup>

(21) Application number: **00109256.8**

(22) Date of filing: **28.04.2000**

(54) **Implantable acoustic bio-sensing system and method**

Implantierbare Vorrichtung zur Erfassung von Biosignalen mit akustischer Übertragung

Dispositif de détection de signaux biologiques utilisant une liaison acoustique

(84) Designated Contracting States:  
**AT BE CH CY DE DK ES FI FR GB GR IE IT LI LU MC NL PT SE**

(30) Priority: **03.05.1999 US 303644**

(43) Date of publication of application:  
**08.11.2000 Bulletin 2000/45**

(73) Proprietor: **Remon Medical Technologies Ltd.**  
**Seasarea 38900 (IL)**

(72) Inventors:  
• **Porat, Yariv**  
**Haifa 34366 (IL)**

• **Penner, Avi**  
**Tel Aviv 69127 (IL)**  
• **Doron, Eyal**  
**Kiryat Yam 29500 (IL)**

(74) Representative: **Pfenning, Meinig & Partner GbR**  
**Patent- und Rechtsanwälte**  
**Joachimstaler Strasse 12**  
**10719 Berlin (DE)**

(56) References cited:  
**WO-A-97/33513** **US-A- 4 198 987**  
**US-A- 4 473 769** **US-A- 4 494 950**  
**US-A- 5 704 352** **US-A- 5 749 909**

**EP 1 050 264 B1**

Note: Within nine months from the publication of the mention of the grant of the European patent, any person may give notice to the European Patent Office of opposition to the European patent granted. Notice of opposition shall be filed in a written reasoned statement. It shall not be deemed to have been filed until the opposition fee has been paid. (Art. 99(1) European Patent Convention).

**Description**FIELD AND BACKGROUND OF THE INVENTION

5 **[0001]** The present invention relates to a biosensing system and method for monitoring internal physiological conditions of a patient. More particularly, the present invention relates to a biosensor system implantable in a patient's body that includes at least one sensor, an active acoustic transducer and a miniature processor. The sensor is used to monitor a physiological condition of the patient and relay information pertaining to the physiological condition through the miniature processor to the active acoustic transducer. The active acoustic transducer transmits this information out of the patient's  
10 body as an acoustic signal. Transmission of an acoustic signal from the transducer is triggered by an externally generated acoustic interrogation and energizing signal, which is produced by a second acoustic transducer positioned externally, yet in intimate contact with, the patient's body. The miniature electronic processor is utilized for the various required functions such as conditioning, digitization and amplification of the sensor signals. The biosensor of the present invention can also include a shunt and a monitoring device embedded in the walls of the shunt for permitting identification and  
15 non-invasive testing of the operation of the shunt via the acoustic transducer.

**[0002]** Many medical conditions require the monitoring and measurement of internal physiological conditions of a patient. For example, hydrocephalus, which is a brain condition where cerebrospinal fluid accumulates at abnormally high pressures in ventricles or chambers of a patient's brain, may require monitoring of the intra-cranial fluid pressure of the patient.

20 **[0003]** Implantable devices for monitoring internal physiological conditions of a patient are known in the art. One such prior art device includes an implantable pressure sensor that transmits pressure signals out of the patient by mechanism of a wire or contact passing through the patient's skull (see, for example, U.S. Pat. No. 4,677,985). These types of devices are generally unsatisfactory due to increased risk of infection and patient discomfort caused by the externally extending wire.

25 **[0004]** Monitoring devices that are completely implantable within a patient are also known in the art. One such prior art device is described in U.S. Pat. No. 4,471,786 and includes a sensor for sensing a physiological condition of the patient and a transmitter and battery assembly for transmitting the sensor signals out of the patient's body. These types of devices are also unsatisfactory for many types of medical conditions since the batteries are bulky and must be periodically replaced, thus necessitating additional surgery.

30 **[0005]** Implantable monitoring devices that do not require batteries have also been developed. Such devices (see, for example, U.S. Pat. Nos. 3,943,915 and 4,593,703) employ sensors coupled with frequency tuned Lumped-Constant (L-C) circuits. The sensors mechanically translate changes in sensed physiological condition to the inductor or capacitor of the tuned L-C circuit for changing the reactance of the L-C circuit. This change in reactance alters the resonant frequency of the circuit, which is then detected by an external receiver and converted to a signal representative of the  
35 monitored physiological condition.

**[0006]** Although these L-C type implantable monitoring devices are superior to battery operated devices in some respects, they also suffer from several limitations that limit their utility. For example, the L-C circuits are difficult to calibrate once implanted, are inherently single-channel, and are only sensitive in a particular range of measurements. Thus, L-C type monitoring devices are not always accurate after they have been implanted for a long period of time and are not  
40 suitable for use with sensors that have a wide sensing range. In addition, no processing power is provided.

**[0007]** Another implantable monitoring device that does not utilize wire connection or a battery supply makes use of large electromagnetic antennae to provide the energy required for the data processing inside the body. These antennas are big and risky to implant. Also, due to the high absorption of electromagnetic energy by human tissue, only subcutaneous implants are used, and energy into the depth of the body is realized by wiring coupling. Only small amounts of  
45 electromagnetic energy can be transmitted from an external antenna directly to a monitoring device deep in the body.

**[0008]** A general limitation of all of the above-described prior art implantable monitoring devices is that they are operable for sensing or monitoring only one physiological condition. Thus, if a doctor wishes to monitor, e.g., both the pressure and the temperature of the fluid in the ventricles of a patient's brain, two such devices must be implanted.

50 **[0009]** Furthermore, these prior art implantable devices merely monitor a physiological condition of the patient and transmit a signal representative of the condition out of the patient's body, but do not perform any processing or conversion of the signals.

**[0010]** In addition, due to inherent design limitations, these devices cannot be utilized for alleviating the underlying cause of the physiological condition monitored. For example, intra-cranial pressure sensors designed for use with patients suffering from hydrocephalus merely detect when fluid pressure levels within the patient's brain are high, but are not  
55 operable for reducing the amount of cerebrospinal fluid accumulated in the patient's brain. Thus, once these prior intra-cranial pressure sensors determine that the pressure in the patient's brain is too high, surgery must be performed to alleviate the condition.

**[0011]** An improved implantable biosensor for monitoring and alleviating internal physiological condition such as in-

tracranial pressure has been described in U.S. Pat. No. 5,704,352 which discloses a biosensor system which includes at least one sensor for monitoring a physiological condition of the patient and a passive radio frequency transducer that receives sensor signals from the sensor or sensors, digitizes the sensor signals, and transmits the digitized signals out of the patient's body when subjected to an externally generated electromagnetically interrogation and energizing signal. The biosensor system described also includes a shunt, and as such it can be used for alleviating intracranial pressure monitored by the sensors of the biosensor.

**[0012]** Although this biosensor system presents a major advance over the above mentioned prior art devices and systems, it suffers from limitations inherent to the radio frequency transducer utilized thereby. Since this transducer requires the use of an antenna to receive and transmit signals, it possesses limited reception and transmission capabilities due to the directional nature of such antennas. In addition, due to the high absorption of electromagnetic energy by human tissue, deeply embedded implants cannot be realized by this system and as a result, the intra body positioning of such a biosensor is limited to regions close to the skin which are accessible to electromagnetic signals, thus greatly limiting the effectiveness of such a system.

**[0013]** In WO 97/33513 a bio-sensing transponder for implantation in an organism including human is disclosed. The bio-sensing transponder comprises a biosensor for sensing one or more physical properties related to the organism after the device has been implanted and a transponder for wirelessly transmitting data corresponding to the sensed parameter value to a remote reader. Energy may be provided in the form of ultrasonic vibration, while a piezo-electronic transducer is utilized to transmit data from a control circuit to a remote ultrasonic reader or to generate electric potentials.

**[0014]** There is thus a widely recognized need for, and it would be highly advantageous to have, a biosensor system for monitoring and alleviating internal physiological conditions, such as intra-cranial pressure, devoid of the above limitations.

#### SUMMARY OF THE INVENTION

**[0015]** It is therefore an object of the present invention to provide a biosensor which can be used for non-invasive monitoring of body parameters.

**[0016]** It is another object of the present invention to provide such a biosensor which does not require wiring or an integral power source.

**[0017]** It is yet another object of the present invention to provide a biosensor which is less sensitive to extracorporeal positional effect when energized as compared to prior art devices.

**[0018]** It is still another object of the present invention to provide a biosensor which is effectively operable from any depth within the body.

**[0019]** To realize and reduce down to practice these objectives, the biosensor according to the present invention takes advantage of the reliable conductivity of acoustic radiation within water bodies, such as a human body and of an acoustic activatable piezoelectric transducer.

**[0020]** According to one aspect of the present invention there is provided an implantable biosensor system for monitoring a physiological condition in a patient, the biosensor system comprising:

(a) at least one sensor for sensing at least one parameter of a physiological condition and for generating electrical sensor signals representative of the physiological condition; and

(b) a processor

(c) a first acoustic activatable transducer being directly or indirectly coupled with said at least one sensor, said first acoustic activatable transducer being for converting a received acoustic interrogation signal from outside the patient's body into an electrical power for energizing said processor, said first acoustic activatable transducer further being for converting said electrical sensor signals of said at least one sensor into acoustic signals receivable out of the patient's body, such that information pertaining to said at least one parameter of the physiological condition can be relayed outside the patient's body upon generation of an acoustic interrogation signal, said first acoustic activatable transducer having dimensions, and further having a resonant wavelength which is significantly larger than said dimensions,

wherein said first acoustic activatable transducer includes:

(i) a cell member having a cavity;

(ii) a substantially flexible piezoelectric layer attached to said cell member, said piezoelectric layer having an external surface and an internal surface, said piezoelectric layer featuring such dimensions so as to enable fluctuations thereof at its resonance frequency upon impinging of said acoustic interrogation signal; and

(iii) a first electrode attached to said external surface and a second electrode attached to said internal surface.

[0021] According to further features in preferred embodiments of the invention described below, the biosensor system further comprising a processor coupling between the at least one sensor and the first acoustic activatable transducer, the processor being for converting the electrical sensor signals into converted electrical signals representative of the physiological condition, the processor being energized via the electrical power.

5 [0022] According to another aspect of the present invention there is provided an implantable biosensor system for monitoring and alleviating a physiological condition in a patient, the biosensor system comprising (a) a shunt having a fluid passageway and being operable for draining fluid through the fluid passageway from a portion of a patient's body; (b) a monitoring and operating mechanism coupled with the shunt for non-invasively monitoring the physiological condition and operating the shunt, the monitoring and operating mechanism including at least one sensor for sensing at least one  
10 parameter of the physiological condition and for generating electrical sensor signals representative of the physiological condition; and (c) a first acoustic activatable transducer being directly or indirectly coupled with the at least one sensor, the first acoustic activatable transducer being for converting a received acoustic interrogation signal from outside the patient's body into an electrical power for energizing the at least one sensor and for operating the shunt upon command, the first acoustic activatable transducer further being for converting the electrical sensor signals into acoustic signals  
15 receivable out of the patient's body, such that information pertaining to the at least one parameter of the physiological condition can be relayed outside the patient's body upon generation of an acoustic interrogation signal and the shunt is operable upon command.

[0023] According to still further features in the described preferred embodiments the monitoring and operating mechanism further includes a processor coupled with the at least one sensor, the processor serves for converting the electrical  
20 sensor signals to converted electrical signals representative of the physiological condition.

[0024] According to still further features in the described preferred embodiments the command is an acoustic operation signal provided from outside the body.

[0025] According to still further features in the described preferred embodiments the shunt is a cerebrospinal fluid shunt for draining cerebrospinal fluid from the patient's brain.

25 [0026] According to still further features in the described preferred embodiments the at least one sensor includes a first pressure sensor positioned within the fluid passageway for sensing the pressure of the cerebrospinal fluid in the patient's brain and for generating a first pressure signal representative of that pressure.

[0027] According to still further features in the described preferred embodiments the at least one pressure sensor includes a second pressure sensor positioned at a distance from the first pressure sensor and being for sensing the  
30 pressure of the cerebrospinal fluid when flowing through the shunt and for generating a second pressure signal representative of that pressure.

[0028] According to still further features in the described preferred embodiments the processor receives the first and second pressure signals from the first and second pressure sensors and calculates the flow rate of cerebrospinal fluid through the shunt.

35 [0029] As described in the above embodiments the first acoustic activatable transducer includes (i) a cell member having a cavity; (ii) a substantially flexible piezoelectric layer attached to the cell member, the piezoelectric layer having an external surface and an internal surface, the piezoelectric layer featuring such dimensions so as to enable fluctuations thereof at its resonance frequency upon impinging of the acoustic interrogation signal; and (iii) a first electrode attached to the external surface and a second electrode attached to the internal surface.

40 [0030] According to still further features in the described preferred embodiments the piezoelectric layer is of a material selected from the group consisting of PVDF and piezoceramic.

[0031] According to still further features in the described preferred embodiments the processor includes a conditioner and a digitizer for converting the electrical sensor signal to the converted electrical signal.

45 [0032] According to still further features in the described preferred embodiments the converted electrical signal is a digital signal.

[0033] According to still further features in the described preferred embodiments the processor, the first acoustic activatable transducer and the at least one sensor are co-integrated into a single biosensor device.

[0034] According to still further features in the described preferred embodiments the biosensor system further comprising (c) an extracorporeal station positionable against the patient's body the extracorporeal station including an interrogation signal generator for generating the acoustic interrogation signal, the interrogation signal generator including  
50 at least one second transducer for transmitting the interrogation signal to the first acoustic activatable transducer and for receiving the receivable acoustic signals from the first acoustic activatable transducer.

[0035] According to still further features in the described preferred embodiments the processor includes a memory device for storing the electrical sensor signals and an analyzer for analyzing the electrical sensor signals.

55 [0036] According to still further features in the described preferred embodiments the processor includes a programmable microprocessor.

[0037] According to still further features in the described preferred embodiments the at least one sensor is selected from the group consisting of a pressure sensor, a temperature sensor, a pH sensor, a blood sugar sensor, a blood

oxygen sensor, a motion sensor, a flow sensor, a velocity sensor, an acceleration sensor, a force sensor, a strain sensor, an acoustics sensor, a moisture sensor, an osmolarity sensor, a light sensor, a turbidity sensor, a radiation sensor, an electromagnetic field sensor, a chemical sensor, an ionic sensor, and an enzymatic sensor.

**[0038]** According to still further features in the described preferred embodiments the first acoustic activatable transducer is capable of transmitting an identification code identifying the transducer.

**[0039]** Not belonging to the present invention there is provided a method for non-invasive monitoring of a physiological condition within a patient's body, the method comprising the steps of (a) sensing at least one parameter associated with the physiological condition via at least one sensor implanted within the patient's body to thereby obtain information pertaining to the physiological condition as an electrical output; (b) converting the electrical output into an acoustic signal via an acoustic transducer and thereby acoustically relaying the information to outside the patient's body; and (c) relaying an acoustic interrogation signal from outside the patient's body for activating the at least one sensor.

**[0040]** Not belonging to the present invention there is provided a method for non-invasive monitoring and alleviating of a physiological condition within a patient's body, the method comprising the steps of (a) sensing at least one parameter associated with the physiological condition via at least one sensor implanted within the patient's body to thereby obtain information pertaining to the physiological condition as an electrical output; (b) converting the electrical output into an acoustic signal via an acoustic transducer and thereby acoustically relaying the information to outside the patient's body; and (c) relaying an acoustic interrogation signal from outside the patient's body for activating the at least one sensor and further for activating a shunt for alleviating the physiological condition.

**[0041]** The present invention successfully addresses the shortcomings of the presently known configurations by providing a biosensor which can be used for non-invasive monitoring of body parameters, which does not require wiring, which does not require an integral power source, which can be effectively positioned at any location and depth within the body and which is much less subject to interrogation positional effect as compared with prior art devices.

#### BRIEF DESCRIPTION OF THE DRAWINGS

**[0042]** The invention is herein described, by way of example only, with reference to the accompanying drawings, wherein:

FIG. 1a is a longitudinal cross section of a transducer element according to the present invention taken along lines A-A in Figures 2a-2e;

FIG. 1b is a longitudinal cross section of a transducer element according to the present invention taken along lines B-B in FIGs. 2a-2e;

FIG. 2a is a cross section of a transducer element according to the present invention taken along line C-C in FIG. 1a;

FIG. 2b is a cross section of a transducer element according to the present invention taken along line D-D in FIG. 1a;

FIG. 2c is a cross section of a transducer element according to the present invention taken along line E-E in FIG. 1a;

FIG. 2d is a cross section of a transducer element according to the present invention taken along line F-F in FIG. 1a;

FIG. 2e is a cross section of a transducer element according to the present invention taken along line G-G in FIG. 1a;

FIG. 3 shows the distribution of charge density across a piezoelectric layer of a transducer element resulting from the application of a constant pressure over the entire surface of the layer;

FIG. 4 shows the results of optimization performed for the power response of a transducer according to the present invention;

FIG. 5 shows a preferred electrode shape for maximizing the power response of a transducer according to the present invention;

FIG. 6 is a longitudinal section of another embodiment of a transducer element according to the present invention capable of functioning as a transmitter;

FIG. 7a-7f are schematic views of possible configurations of transmitters according to the present invention including parallel and anti-parallel electrical connections for controllably changing the mechanical impedance of the piezoelectric layer;

FIG. 8 is a longitudinal section of a transmitter element according to the present invention including an anti-parallel electrical connection;

FIG. 9 is a longitudinal section of another embodiment of a transmitter element according to the present invention;

FIG. 10 is a block diagram depicting the intrabody and extracorporeal components of the biosensor system according to the present invention;

FIG. 11 is a schematic depiction of components of the biosensor system according to one embodiment of the present invention;

FIG. 12 is a longitudinal section of a shunt system including an acoustic transducer and pressure sensors according to another embodiment of the present invention;

FIG. 13 is a schematic depiction of the transducer and pressure sensors of Figure 12 isolated from the shunt; and

FIG. 14 is a block diagram of the extracorporeal station components according to the present invention implemented within a helmet.

#### DESCRIPTION OF THE PREFERRED EMBODIMENTS

5 [0043] The present invention is of an intrabody bio-sensing system which can be used for both monitoring and alleviating physiological conditions within a patient's body. Specifically, the biosensor system of the present invention incorporates an active acoustic transducer communicating with sensors and optionally with a shunt implanted within the patient's body for monitoring and alleviating, for example, intra-cranial pressure of a patient suffering from hydrocephalus.

10 [0044] The principles and operation of an implantable biosensor system according to the present invention may be better understood with reference to the drawings and accompanying descriptions.

15 [0045] Before explaining at least one embodiment of the invention in detail, it is to be understood that the invention is not limited in its application to the details of construction and the arrangement of the components set forth in the following description or illustrated in the drawings. The invention is capable of other embodiments or of being practiced or carried out in various ways. Also, it is to be understood that the phraseology and terminology employed herein is for the purpose of description and should not be regarded as limiting. For purposes of better understanding the system according to the present invention, as illustrated in Figures 10-14 of the drawings, reference is first made to the construction and operation of a transducer as described in U.S. Pat. application No. 09/000,553.

20 [0046] Referring now to the drawings, Figures 1a, 1b and 2a-2e illustrate a preferred embodiment of a transducer element according to the present invention which is referred to herein as transducer element 1. Transducer element 1 serves for converting received acoustic signals into electrical power and for converting electrical power to transmitted acoustic signals. As shown in the figures, the transducer element 1 includes at least one cell member 3 including a cavity 4 etched into a substrate and covered by a substantially flexible piezoelectric layer 2. Attached to piezoelectric layer 2 are an upper electrode 8 and a lower electrode 6, the electrodes for connection to an electronic circuit.

25 [0047] The substrate is preferably made of an electrical conducting layer 11 disposed on an electrically insulating layer 12, such that cavity 4 is etched substantially through the thickness of electrically conducting layer 11.

30 [0048] Electrically conducting layer 11 is preferably made of copper and insulating layer 12 is preferably made of a polymer such as polyimide. Conventional copper-plated polymer laminate such as KAPTON™ sheets may be used for the production of transducer element 1. Commercially available laminates such as NOVACLAD™ may be used. Alternatively, the substrate may include a silicon layer, or any other suitable material. Alternatively, layer 11 is made of a non-conductive material such as PYRALIN™.

35 [0049] Preferably, cavity 4 is etched into the substrate by using conventional printed-circuit photolithography methods. Alternatively, cavity 4 may be etched into the substrate by using VLSI/micro-machining technology or any other suitable technology.

40 [0050] Piezoelectric layer 2 may be made of PVDF or a copolymer thereof. Alternatively, piezoelectric layer 2 is made of a substantially flexible piezoceramic. Preferably, piezoelectric layer 2 is a poled PVDF sheet having a thickness of about 9-28 μm. Preferably, the thickness and radius of flexible layer 2, as well as the pressure within cavity 4, are specifically selected so as to provide a predetermined resonant frequency. When using the embodiment of Figures 1a and 1b, the radius of layer 2 is defined by the radius of cavity 4.

45 [0051] By using a substantially flexible piezoelectric layer 2, the invention described in U.S. Pat. application No. 09/000,553 allows to provide a miniature transducer element whose resonant frequency is such that the acoustic wavelength is much larger than the extent of the transducer. This enables the transducer to be omnidirectional even at resonance, and further allows the use of relatively low frequency acoustic signals which do not suffer from significant attenuation in the surrounding medium.

50 [0052] Prior art designs of miniature transducers, however, rely on rigid piezoceramic usually operating in thickness mode. In such cases the resonant frequency relates to the size of the element and speed of sound in the piezoceramic, and is higher by several orders of magnitude.

[0053] The invention described in U.S. Pat. application No. 09/000,553 provides a transducer which is omnidirectional, i.e., insensitive to the direction of the impinging acoustic rays, thereby substantially simplifying the transducer's operation relative to other resonant devices. Such a transducer element is thus suitable for application in confined or hidden locations, where the orientation of the transducer element cannot be ascertained in advance.

55 [0054] According to a specific embodiment, cavity 4 features a circular or hexagonal shape with radius of about 200 μm. Electrically conducting layer 11 preferably has a thickness of about 15 μm. Cell member 3 is preferably etched completely through the thickness of electrically conducting layer 11. Electrically insulating layer 12 preferably features a thickness of about 50 μm. The precise dimensions of the various elements of a transducer element according to the invention described in U.S. Pat. application No. 09/000,553 may be specifically tailored according to the requirements of the specific application.

[0055] Cavity 4 preferably includes a gas such as air. The pressure of gas within cavity 4 may be specifically selected

so as to predetermine the sensitivity and ruggedness of the transducer as well as the resonant frequency of layer 2.

[0056] As shown in Figure 2b, an insulating chamber 18 is etched into the substrate, preferably through the thickness of conducting layer 11, so as to insulate the transducer element from other portions of the substrate which may include other electrical components such as other transducer elements etched into the substrate. According to a specific embodiment, the width of insulating chamber 18 is about 100 μm. As shown, insulating chamber 18 is etched into the substrate so as to form a wall 10 of a predetermined thickness enclosing cavity 4, and a conducting line 17 integrally made with wall 10 for connecting the transducer element to another electronic component preferably etched into the same substrate, or to an external electronic circuit.

[0057] As shown in Figures 1a and 1b, attached to piezoelectric layer 2 are upper electrode 8 and lower electrode 6. As shown in Figures 2c and 2e, upper electrode 8 and lower electrode 6 are preferably precisely shaped, so as to cover a predetermined area of piezoelectric layer 2. Electrodes 6 and 8 may be deposited on the upper and lower surfaces of piezoelectric membrane 2, respectively, by using various methods such as vacuum deposition, mask etching, painting, and the like.

[0058] As shown in Figure 1a, lower electrode 6 is preferably made as an integral part of a substantially thin electrically conducting layer 14 disposed on electrically conducting layer 11. Preferably, electrically conducting layer 14 is made of a NickelCopper alloy and is attached to electrically conducting layer 11 by mechanism of a sealing connection 16. Sealing connection 16 may be made of indium. According to a preferred configuration, sealing connection 16 may feature a thickness of about 10 μm, such that the overall height of wall 10 of cavity 4 is about 20-25 μm.

[0059] As shown in Figure 2c, electrically conducting layer 14 covers the various portions of conducting layer 11, including wall 10 and conducting line 17. The portion of conducting layer 14 covering conducting line 17 is for connection to an electronic component, as further detailed hereinunder.

[0060] According to a preferred embodiment, electrodes 6 and 8 are specifically shaped to include the most energy-productive region of piezoelectric layer 2, so as to provide maximal response of the transducer while optimizing the electrode area, and therefore the cell capacitance, thereby maximizing a selected parameter such as voltage sensitivity, current sensitivity, or power sensitivity of the transducer element.

[0061] The vertical displacement of piezoelectric layer 2, Ψ, resulting from a monochromatic excitation at angular frequency ω is modeled using the standard equation for thin plates:

$$(\nabla^2 - \gamma^2)(\nabla^2 + \gamma^2)\Psi - \frac{3(1 - \nu^2)}{2Qh^3} P + \frac{3iZ\omega(1 - \nu^2)}{2Qh^3} \bar{\Psi} = 0$$

wherein Q is the Young's modulus representing the elasticity of layer 2; h the half-thickness of layer 2; ν is the Poisson ratio for layer 2; γ is the effective wavenumber in the layer given by:  $\gamma^4 = 3\rho(1 - \nu^2)\omega^2/Qh^2$ ,

wherein ρ is the density of layer 2 and ω is the angular frequency of the applied pressure (wherein the applied pressure may include the acoustic pressure, the static pressure differential across layer 2 and any other pressure the transducer comes across); Z is the mechanical impedance resulting from the coupling of layer 2 to both external and internal media of cavity 4, wherein the internal medium is preferably air and the external medium is preferably fluid; P is the acoustic pressure applied to layer 2, and  $\bar{\Psi}$  represents the average vertical displacement of layer 2.

[0062] When chamber 4 is circular, the solution (given for a single frequency component ω) representing the dynamic displacement of a circular layer 2 having a predetermined radius a, expressed in polar coordinates, is:

$$\Psi(r, \varphi) = \frac{I_1(\gamma a)[J_0(\gamma r) - J_0(\gamma a)] + J_1(\gamma a)[I_0(\gamma r) - I_0(\gamma a)]}{2h\rho\omega^2 L_0(\gamma a) + i\omega Z L_2(\gamma a)} P$$

$$L_0(z) = I_0(z)J_1(z) + J_0(z)I_1(z), \quad L_2(z) = J_2(z)I_1(z) - I_2(z)J_1(z)$$

$$Z = \frac{P_A}{i\omega H_A} + i \left[ \frac{4}{3\pi} + \frac{1}{6} \right] \omega \rho_w a$$

wherein Ψ(r,φ) is time-dependent and represents the displacement of a selected point located on circular layer 2, the

specific location of which is given by radius  $r$  and angle  $\varphi$ ;  $J$  and  $I$  are the normal and modified Bessel functions of the first kind, respectively;  $P_A$ ,  $H_A$ , are the air pressure within cavity **4** and the height of chamber **4**, respectively; and  $\rho_w$  is the density of the fluid external to cavity **4**.

[0063] The first term of the impedance  $Z$  relates to the stiffness resulting from compression of air within cavity **4**, and the second term of  $Z$  relates to the mass added by the fluid boundary layer. An additional term of the impedance  $Z$  relating to the radiated acoustic energy is substantially negligible in this example.

[0064] The charge collected between electrodes **6** and **8** per unit area is obtained by evaluating the strains in layer **2** resulting from the displacements, and multiplying by the pertinent off-diagonal elements of the piezoelectric strain coefficient tensor,  $e_{31}$ ,  $e_{32}$ , as follows:

$$Q(r, \varphi, t) = e_{31} \left( \frac{\partial \Psi}{\partial x} \right)^2 + e_{32} \left( \frac{\partial \Psi}{\partial y} \right)^2$$

wherein  $Q(r, \varphi, t)$  represents the charge density at a selected point located on circular layer **2**, the specific location of which is given by radius  $r$  and angle  $\varphi$ ;  $x$  is the stretch direction of piezoelectric layer **2**;  $y$  is the transverse direction (the direction perpendicular to the stretch direction) of layer **2**;  $e_{31}$ ,  $e_{32}$ , are off-diagonal elements of the piezoelectric strain coefficient tensor representing the charge accumulated at a selected point on layer **2** due to a given strain along the  $x$  and  $y$  directions, respectively, which coefficients being substantially dissimilar when using a PVDF layer.  $\Psi$  is the displacement of layer **2**, taken as the sum of the displacement for a given acoustic pressure  $P$  at frequency  $f$ , and the static displacement resulting from the pressure differential between the interior and exterior of cavity **4**, which displacements being extractable from the equations given above.

[0065] The total charge accumulated between electrodes **6** and **8** is obtained by integrating  $Q(r, \varphi, t)$  over the entire area  $S$  of the electrode:

$$Q = \int_S Q(r, \varphi, t) d\bar{x}$$

[0066] The capacitance  $C$  of piezoelectric layer **2** is given by:  $C = \frac{\epsilon}{2h} \int_S d\bar{x}$ , wherein  $\epsilon$  is the dielectric constant of piezoelectric layer **2**; and  $2h$  is the thickness of piezoelectric layer **2**.

[0067] Accordingly, the voltage, current and power responses of piezoelectric layer **2** are evaluated as follows:

$$V = \frac{2h \int_S Q(r, \varphi, t) d\bar{x}}{\epsilon \int_S d\bar{x}}, \quad I = 2i\omega \int_S Q(r, \varphi, t) d\bar{x}, \quad W = \frac{4ih \left[ \int_S Q(r, \varphi, t) d\bar{x} \right]^2}{\epsilon \int_S d\bar{x}}$$

[0068] The DC components of  $Q$  are usually removed prior to the evaluation, since the DC currents are usually filtered out. The values of  $Q$  given above represent peak values of the AC components of  $Q$ , and should be modified accordingly, so as to obtain other required values such as RMS values.

[0069] According to the above, the electrical output of the transducer expressed in terms of voltage, current and power responses depend on the AC components of  $Q$ , and on the shape  $S$  of the electrodes. Further, as can be seen from the above equations, the voltage response of the transducer may be substantially maximized by minimizing the area of the electrode. The current response, however, may be substantially maximized by maximizing the area of the electrode.

[0070] Figure 3 shows the distribution of charge density on a circular piezoelectric layer **2** obtained as a result of pressure (acoustic and hydrostatic) applied uniformly over the entire area of layer **2**, wherein specific locations on layer **2** are herein defined by using Cartesian coordinates including the stretch direction ( $x$  direction) and the transverse direction ( $y$  direction) of layer **2**. It can be seen that distinct locations on layer **2** contribute differently to the charge density.

The charge density vanishes at the external periphery **70** and at the center **72** of layer **2** due to minimal deformation of these portions. The charge density is maximal at two cores **74a** and **74b** located symmetrically on each side of center **72** due to maximal strains (in the stretch direction) of these portions.

**[0071]** A preferred strategy for optimizing the electrical responses of the transducer is to shape the electrode by selecting the areas contributing at least a selected threshold percentage of the maximal charge density, wherein the threshold value is the parameter to be optimized. A threshold value of 0 % relates to an electrode covering the entire area of layer **2**.

**[0072]** Figure 4 shows the results of an optimization performed for the power response of a transducer having a layer **2** of a predetermined area. As shown in the Figure, the threshold value which provides an optimal power response is about 30 % (graph b). Accordingly, an electrode which covers only the portions of layer **2** contributing at least 30 % of the maximal charge density yields a maximal power response. The pertinent voltage response obtained by such an electrode is higher by a factor of 2 relative to an electrode completely covering layer **2** (graph a). The current response obtained by such electrode is slightly lower relative to an electrode completely covering layer **2** (graph c). Further as shown in the Figure, the deflection of layer **2** is maximal when applying an acoustic signal at the resonant frequency of layer **2** (graph d).

**[0073]** A preferred electrode shape for maximizing the power response of the transducer is shown in Figure 5, wherein the electrode includes two electrode portions **80a** and **80b** substantially covering the maximal charge density portions of layer **2**, the electrode portions being interconnected by mechanism of a connecting member **82** having a minimal area. Preferably, portions **80a** and **80b** cover the portions of layer **2** which yield at least a selected threshold (e.g. 30 %) of the maximal charge density.

**[0074]** According to the present invention any other parameter may be optimized so as to determine the shape of electrodes **6** and **8**. According to further features of the invention described in U.S. Pat. application No. 09/000,553, only one electrode (upper electrode **8** or lower electrode **6**) may be shaped so as to provide maximal electrical response of the transducer, with the other electrode covering the entire area of layer **2**. Since the charge is collected only at the portions of layer **2** received between upper electrode **8** and lower electrode **6**, such configuration is operatively equivalent to a configuration including two shaped electrodes having identical shapes.

**[0075]** Referring now to Figure 6, according to another embodiment chamber **4** of transducer element **1** may contain gas of substantially low pressure, thereby conferring a substantially concave shape to piezoelectric membrane **2** at equilibrium. Such configuration enables to further increase the electrical response of the transducer by increasing the total charge obtained for a given displacement of layer **2**. The total displacement in such an embodiment is given by:  $\psi = P_0\psi_{DC} + P\psi_{AC} \cos\omega t$ , wherein  $P_0$  is the static pressure differential between the exterior and the interior of cavity **4**;  $\psi_{DC}$  is the displacement resulting from  $P_0$ ;  $P$  is the amplitude of the acoustic pressure; and  $\psi_{AC}$  is the displacement resulting from  $P$ .

**[0076]** Accordingly, the strain along the x direction includes three terms as follows:

$$S_{xx} = \left( \frac{\partial \psi}{\partial x} \right)^2 = P_0^2 \left( \frac{\partial \psi_{DC}}{\partial x} \right)^2 + P^2 \left( \frac{\partial \psi_{AC}}{\partial x} \right)^2 \cos^2 \omega t + 2P_0P \frac{\partial \psi_{DC}}{\partial x} \frac{\partial \psi_{AC}}{\partial x} \cos \omega t$$

wherein the DC component is usually filtered out.

**[0077]** Thus, by decreasing the pressure of the medium (preferably air) within cavity **4** relative to the pressure of the external medium (preferably fluid), the value of  $P_0$  is increased, thereby increasing the value of the third term of the above equation.

**[0078]** Such embodiment makes it possible to increase the charge output of layer **2** for a given displacement, thereby increasing the voltage, current and power responses of the transducer without having to increase the acoustic pressure  $P$ . Furthermore, such embodiment enables to further miniaturize the transducer since the same electrical response may be obtained for smaller acoustic deflections. Such embodiment is substantially more robust mechanically and therefore more durable than the embodiment shown in Figures 1a and 1b. Such further miniaturization of the transducer enables to use higher resonance frequencies relative to the embodiment shown in Figures 1a and 1b.

**[0079]** Preferably, a transducer element **1** according to the invention described in U.S. Pat. application No. 09/000,553 is fabricated by using technologies which are in wide use in the microelectronics industry, so as to allow integration thereof with other conventional electronic components as further detailed hereinunder. When the transducer element includes a substrate such as Copper-polymer laminate or silicon, a variety of conventional electronic components may be fabricated onto the same substrate.

**[0080]** According to a preferred embodiment, a plurality of cavities **4** may be etched into a single substrate **12** and covered by a single piezoelectric layer **2**, so as to provide a transducer element including a matrix of transducing cell members **3**, thereby providing a larger energy collecting area of predetermined dimensions, while still retaining the

advantage of miniature individual transducing cell members **3**. When using such configuration, the transducing cell members **3** may be electrically interconnected in parallel or serial connections, or combinations thereof, so as to tailor the voltage and current response of the transducer. Parallel connections are preferably used so as to increase the current output while serial connections are preferably used so as to increase the voltage output of the transducer.

5 **[0081]** Furthermore, piezoelectric layer **2** may be completely depolarized and then repolarized at specific regions thereof, so as to provide a predetermined polarity to each of the transducing cell members **3**. Such configuration enables to reduce the complexity of interconnections between cell members **3**.

**[0082]** A transducer element according to the invention described in U.S. Pat. application No. 09/000,553 may be further used as a transmitter for transmitting information to a remote receiver by modulating the reflection of an external impinging acoustic wave arrived from a remote transmitter.

10 **[0083]** Referring to Figure 6, the transducer element shown may function as a transmitter element due to the asymmetric fluctuations of piezoelectric layer **2** with respect to positive and negative transient acoustic pressures obtained as a result of the pressure differential between the interior and exterior of cavity **4**.

**[0084]** A transmitter element according to the present invention preferably modulates the reflection of an external impinging acoustic wave by mechanism of a switching element connected thereto. The switching element encodes the information that is to be transmitted, such as the output of a sensor, thereby frequency modulating a reflected acoustic wave.

15 **[0085]** Such configuration requires very little expenditure of energy from the transmitting module itself, since the acoustic wave that is received is externally generated, such that the only energy required for transmission is the energy of modulation.

20 **[0086]** Specifically, the reflected acoustic signal is modulated by switching the switching element according to the frequency of a message electric signal arriving from another electronic component such as a sensor, so as to controllably change the mechanical impedance of layer **2** according to the frequency of the message signal.

**[0087]** Preferably, a specific array of electrodes connected to a single cell member or alternatively to a plurality of cell members are used, so as to control the mechanical impedance of layer **2**.

25 **[0088]** Figures 7a-7g illustrate possible configurations for controllably change the impedance of layer **2** of a transmitter element. Referring to Figure 7a, a transmitter element according to the invention described in U.S. Pat. application No. 09/000,553 may include a first and second pairs of electrodes, the first pair including an upper electrode **40a** and a lower electrode **38a**, and the second pair including an upper electrode **40b** and a lower electrode **38b**. Electrodes **38a**, **38b**, **40a** and **40b** are electrically connected to an electrical circuit by mechanism of conducting lines **36a**, **36b**, **34a** and **34b**, respectively, the electrical circuit including a switching element (not shown), so as to alternately change the electrical connections of conducting lines **36a**, **36b**, **34a** and **34b**.

30 **[0089]** Preferably, the switching element switches between a parallel connection and an anti-parallel connection of the electrodes. A parallel connection decreases the mechanical impedance of layer **2**, wherein an anti-parallel connection increases the mechanical impedance of layer **2**. An anti-parallel connection may be obtained by interconnecting line **34a** to **36b** and line **34b** to **36a**. A parallel connection may be obtained by connecting line **34a** to **34b** and line **36a** to **36b**. Preferably, the switching frequency equals the frequency of a message signal arriving from an electrical component such as a sensor as further detailed hereinunder.

35 **[0090]** According to another embodiment shown in Figure 7b, upper electrode **40a** is connected to lower electrode **38b** by mechanism of a conducting line **28**, and electrodes **38a** and **40b** are connected to an electrical circuit by mechanism of conducting lines **27** and **29**, respectively, wherein the electrical circuit further includes a switching element. Such configuration provides an anti-parallel connection of the electrodes, wherein the switching element functions as an on/off switch, thereby alternately increasing the mechanical impedance of layer **2**.

40 **[0091]** In order to reduce the complexity of the electrical connections, layer **2** may be depolarized and then repolarized at specific regions thereof. As shown in Figure 7c, the polarity of the portion of layer **2** received between electrodes **40a** and **38a** is opposite to the polarity of the portion of layer **2** received between electrodes **40b** and **38b**. An anti-parallel connection is thus achieved by interconnecting electrodes **38a** and **38b** by mechanism of a conducting line **28**, and providing conducting lines **27** and **29** connected to electrodes **40a** and **40b**, respectively, the conducting lines for connection to an electrical circuit including a switching element.

45 **[0092]** According to another embodiment, the transmitting element includes a plurality of transducing cell members, such that the mechanical impedance of layer **2** controllably changed by appropriately interconnecting the cell members.

50 **[0093]** As shown in Figure 7d, a first transducing cell member **3a** including a layer **2a** and a cavity **4a**, and a second transducing cell member **3b** including a layer **2b** and a cavity **4b** are preferably contained within the same substrate; and layers **2a** and **2b** are preferably integrally made. A first pair of electrodes including electrodes **6a** and **8a** is attached to layer **2**, and a second pair of electrode including electrodes **6b** and **8b** is attached to layer **2b**. Electrodes **6a**, **8a**, **6b** and **8b** are electrically connected to an electrical circuit by mechanism of conducting lines **37a**, **35a**, **37b** and **35b**, respectively, the electrical circuit including a switching element, so as to alternately switch the electrical connections of conducting lines **37a**, **35a**, **37b** and **35b**, so as to alternately provide parallel and anti-parallel connections, substantially

as described for Figure 7a, thereby alternately decreasing and increasing the mechanical impedance of layers **2a** and **2b**.

**[0094]** Figure 7e illustrates another embodiment, wherein the first and second transducing cell members are interconnected by mechanism of an anti-parallel connection. As shown in the Figure, the polarity of layer **2a** is opposite to the polarity of layer **2b**, so as to reduce the complexity of the electrical connections between cell members **3a** and **3b**. Thus, electrode **6a** is connected to electrode **6b** by mechanism of a conducting line **21**, and electrodes **8a** and **8b** are provided with conducting lines **20** and **22**, respectively, for connection to an electrical circuit which includes a switching element, wherein the switching element preferably functions as an on/off switch, so as to alternately increase the mechanical impedance of layers **2a** and **2b**.

**[0095]** Figure 7f shows another embodiment, wherein the first and second transducing cell members are interconnected by mechanism of a parallel connection. As shown, electrodes **6a** and **6b** are interconnected by mechanism of conducting line **24**, electrodes **8a** and **8b** are interconnected by mechanism of conducting line **23**, and electrodes **6b** and **8b** are provided with conducting lines **26** and **25**, respectively, the conducting lines for connection to an electrical circuit including a switching element. The switching element preferably functions as an on/off switch for alternately decreasing and increasing the mechanical impedance of layers **2a** and **2b**.

**[0096]** Figure 8 shows a possible configuration of two transducing cell members etched onto the same substrate and interconnected by mechanism of an anti-parallel connection. As shown in the Figure, the transducing cell members are covered by a common piezoelectric layer **2**, wherein the polarity of the portion of layer **2** received between electrodes **6a** and **8a** is opposite to the polarity of the portion of layer **2** received between electrodes **6b** and **8b**. Electrodes **8a** and **8b** are bonded by mechanism of a conducting line **9**, and electrodes **6a** and **6b** are provided with conducting lines **16** for connection to an electrical circuit.

**[0097]** Another embodiment of a transmitter element according to the present invention is shown in Figure 9. The transmitter element includes a transducing cell member having a cavity **4** covered by a first and second piezoelectric layers, **50a** and **50b**, preferably having opposite polarities. Preferably, layers **50a** and **50b** are interconnected by mechanism of an insulating layer **52**. Attached to layer **50a** are upper and lower electrodes **44a** and **42a**, and attached to layer **50b** are upper and lower electrodes **44b** and **42b**. Electrodes **44a**, **42a**, **44b** and **42b** are provided with conducting lines **54**, **55**, **56** and **57**, respectively, for connection to an electrical circuit.

**[0098]** It will be appreciated that the above descriptions are intended only to serve as examples, and that many other embodiments are possible within the spirit and the scope of invention described in U.S. Pat. application No. 09/000,553.

**[0099]** As is detailed hereinunder, in preferred embodiments, the present invention exploits the advantages of the acoustic transducer described hereinabove and in U.S. Pat. application No. 09/000,553.

**[0100]** Thus, according to the present invention there is provided an implantable biosensor system, which is referred to hereinunder as biosensor **100**.

**[0101]** Biosensor **100** is implantable within a patient's body for monitoring a physiological condition therein. In the course of its operation, biosensor **100** relays, on command, information in the form of acoustic signals pertaining to a parameter or parameters associated with the physiological condition as these are sensed by an implanted sensor or sensors. Furthermore, biosensor **100** according to the present invention is designed to be energized via an external acoustic interrogation signal.

**[0102]** As such, biosensor **100** is wire and/or integral power source independent. In addition, since the human body is, in effect, a water body and further since acoustic radiation is readily propagatable, if so desired, within water bodies in all directions, biosensor **100** of the present invention provides advantages over the prior art in terms of effective implantable depth within the body and further in terms of interrogation signal positional effect.

**[0103]** As further detailed hereinunder, according to a preferred embodiment of the present invention biosensor system **100** incorporates a shunt for alleviating a monitored physiological condition.

**[0104]** As shown in Figure 10, and according to one embodiment of the present invention, when implanted in a monitoring or treatment intra body site, biosensor **100** of the present invention is employed for sensing or monitoring one or more parameters of a physiological condition within the patient and for transmitting acoustic signals representative of this physiological condition or these parameters out of the patient's body.

**[0105]** According to this embodiment of the present invention, biosensor **100** includes one or more sensors **112** for sensing, monitoring or measuring one or more parameters of the physiological conditions of the patient.

**[0106]** Biosensor **100** also includes an acoustic activatable transducer **114**. Transducer **114** serves for receiving electrical signals from sensors **112** and for converting such electrical signals into acoustic signals. Transducer **114** also serves for receiving externally generated acoustic interrogation signals and for converting such acoustic energy into electrical power which is used for energizing sensors **112** and for rendering biosensor **100** wire and integral power source independent.

**[0107]** As further shown in Figure 10, transducer **114** includes a receiving assembly **117** and a transmitting assembly **118**, preferably both are integrated into a single transceiver assembly.

**[0108]** According to a preferred embodiment of the present invention receiving assembly **117** and transmitting assembly **118** are assembled of transducer element **1**, the construction of which is further detailed hereinabove with regards to

Figures 1a, 1b and 2a-2e. Alternatively, a plurality of transducer elements **1** can also be utilized in various configurations (as shown in Figures 7b-f, 8 and 9 hereinabove) in the receiving assembly **117** and transmitting assembly **118** of biosensor **100** of the present invention. The components of transducer **114** can be formed from separate transducer element **1** units, although the integration of one transducer element **1** into a transceiver is preferred, due to the high degree of miniaturization required in biosensing devices.

**[0109]** According to a preferred embodiment of the present invention signals received and/or transmitted by biosensor **100** are processed by a processor **113**. Electrical signals generated by sensors **112** are processed through processor **113** and are forwarded in their processed or converted form to transducer **114**. In addition, acoustic signals received by transducer **114** and which are converted to electrical signals (and power) thereby, are preferably further processed by processor **113**.

**[0110]** To this end, processor **113**, preferably includes a conditioner **116** and, when necessary, a digitizer **119** for processing the electrical signals received thereby from sensors **112** and/or transducer **114**.

**[0111]** The acoustic interrogation signal is generated by an extracorporeal station **130** which includes an interrogator **115** and which is also illustrated in Figure 10, the operation and construction of which is described in further detail below.

**[0112]** Sensors **112** are operable for monitoring or detecting one or more physiological conditions within the patient's body, such as the pressure and/or the temperature of the cerebrospinal fluid in the cavities or ventricles of the patient's brain. Sensors **112** then generate sensor signals representative of these measured physiological parameters. The sensor signals are typically electrical analog signals but may also be digital, depending on the type of sensor employed. It will be appreciated that sensors having a built-in analog-to-digital converter are well known in the art.

**[0113]** Sensors **112** are preferably conventional in construction and may include, for example, pressure sensors, temperature sensors, pH sensors, blood sugar sensors, blood oxygen sensors, or any other type of physiological sensing, monitoring or measuring devices responsive to, for example, motion, flow, velocity, acceleration, force, strain, acoustics, moisture, osmolarity, light, turbidity, radiation, electromagnetic fields, chemicals, ionic, or enzymatic quantities or changes, electrical and/or impedance.

**[0114]** Examples of these and other sensor devices useful in context of the present invention are described in detail in the AIP Handbook of Modern Sensors by Jacob Fraden, hereby incorporated by reference.

**[0115]** In a preferred embodiment, sensors **112** are pressure sensor transducers such as the PVDF sensors described in U.S. Pat. application 09/161,658, which is incorporated herein by reference, or the MPX2000 series pressure sensors distributed by Motorola.

**[0116]** As mentioned above according to a preferred embodiment of the present invention transducer **114** is electrically coupled to sensors **112** through processor **113**. Processor **113** conditions the sensor signals via conditioner **116**, converts the sensor signals to a digital form (when so required) via digitizer **119**, and provides the processed or converted signal to transducer **114**. Upon a command, transducer **114** converts the processed electrical signals into corresponding acoustic signals which are concomitantly transmitted out of the patient's body, when subjected to an acoustic interrogation signal from station **130**.

**[0117]** In more detail, processor **113** is electrically connected to sensors **112** and both share a common miniature substrate such as is customary in the VLSI (Very Large Scale Integration) industry. Processor **113** directly receives sensors' **112** signals by, e.g., the shortest possible wiring.

**[0118]** Processor **113** serves several functions. As already mentioned, processor **113** conditions via conditioner **116** the signals received from sensors **112**. Such conditioning is necessary due to the miniature size and small capacitance of sensors **112**, and as such, conditioner **116** provides not only appropriate amplification and filtering, but also impedance reduction, so as to substantially reduce noise pickup and thereby improve the signal-to-noise ratio of biosensor **100**.

**[0119]** In addition, digitizer **119** is employed in processor **113** to convert the analog signals to digital signals and format the digitized signals as a binary data stream for transmission out of the patient by transducer **114** acoustic signals, which are received and interpreted by extracorporeal station **130**.

**[0120]** Processor **113** is also operable for coding and formatting a unique device identification number for transmission with the sensors' signals for use in identifying a specific transducer **114** and/or sensor **112**.

**[0121]** Preferably, processor **113** can be programmed to analyze the monitored signals before transmitting the signals out of the patient's body. To this end, processor **113** can be provided with a memory device and a programmable microprocessor. Many more tasks which are applicable to biosensor system **100** of the present invention can be provided by processor **113**, such as, for example, calculating a reading by correlating information derived from a plurality of sensors **112**.

**[0122]** For example, if biosensor **100** is provided with a pressure sensor and a temperature sensor for measuring both the pressure and temperature of the cerebrospinal fluid in the patient's brain, processor **113** can then be programmed to adjust the pressure signal transmitted out of the patient's body to compensate for higher or lower temperature readings as sensed by the temperature sensor and vice versa, thereby providing more accurate readings.

**[0123]** It will, however, be appreciated by one ordinarily skilled in the art that sole or additional/supplementary processing can be effected by processors present in extracorporeal station **130**.

[0124] Preferably, transmitting assembly 118 of transducer 114 employs modulations or other methods in modifying the transmitted acoustic signal, such modulation methods are well known in the art and are described in detail in, for example, U.S. Pat. No. 5,619,997 which is incorporated herein by reference.

5 [0125] Extracorporeal station 130 is located outside the patient's body and is designed for powering or energizing transducer 114 of biosensor 100 which is implanted within the patient's body, and for receiving the sensors' acoustic signals.

10 [0126] As illustrated in Figures 10-11, according to one embodiment of the present invention and as further detailed in the following sections, transducers 321 of station 130 are mounted within a helmet 310. Transducers 321 are coupled via wiring with a signal generator 126, a power amplifier 128, a modulator 132, a demodulator 133, a signal conditioner 134 and a recording and analyzing device 138.

15 [0127] Signal generator 126 and power amplifier 128 provide energy to extracorporeal transducer 321 for generating acoustic signals which propagate from the surface into the patient's body and energize intrabody acoustic transducer 114 when impinging thereon. Signal generator 126 and power amplifier 128 may be of any known type, including devices constructed in accordance with "Data Transmission from an Implantable Biotelemeter by Load-Shift Keying Using Circuit Configuration Modulator" by Zhengnian Tang, Brian Smith, John H. Schild, and P. Hunter Peckham, IEEE Transactions on Biomedical Engineering, vol. 42, No. 5, May, 1995, pp. 524-528, which is incorporated herein by reference.

20 [0128] As already mentioned, transducers 321 are preferably of a type functionally similar to transducer element 1, the construction of which is further described hereinabove in Figures 1a, 1b, 2a-2e, 7b-f, 8 and 9, each of which can serve as a transmitter, receiver or a transceiver, and are preferably constructed to comply with NCRP 113: Exposure criteria for medical diagnostic ultrasound 1992, parts I and II, provided that transducers 321 when serve as a powering transmitter is capable of transmitting sufficient energy in the form of an acoustic signal for energizing biosensor 100. Preferred transducers 321 include commercial piston type transducers.

25 [0129] Transducers 321 are electrically connected to power amplifier 128 and acoustically communicable with transducer 114. Transducers 321 transform and deliver the energy generated by generator 126 and power amplifier 128 to transducer 114 via the body of the patient, which serves in this respect as a water body.

[0130] Demodulator 133 is operatively coupled to transducers 321 and is provided for extracting digital data received thereby from transducer 114. An example of a demodulator 133 that can be used in interrogator 115 of extracorporeal station 130 is the MC1496 or MC1596 type demodulator distributed by Motorola.

30 [0131] Signal conditioner 134 is connected to demodulator 133 for converting the demodulated data to a format suitable for recording or storing in external devices. An example of a signal conditioner 134 that can be used in station 130 of the present invention is the ADM202 type conditioner distributed by Analog Devices. Signal conditioner 134 may be connected with conventional recording and/or analyzing devices such as computers, printers, and displays for recording, presenting and/or further analyzing the signals transmitted by biosensor 100.

35 [0132] Thus, and according to this embodiment of the present invention, biosensor 100 described hereinabove is implanted in a patient for sensing, monitoring or detecting one or more parameters associated with a physiological condition of the patient. When it is desired to collect information from the body of the patient, a control console 124 commands interrogator 115 to trigger an energizing signal output from signal generator 126. The energizing signal is then modulated with other commands originating from control console 124 that governs processor 113 of biosensor 100 and multiplexer-demultiplexer 381. The modulated signal is amplified by power amplifier 128 and sent to transducer 321 to energize and render biosensor 100 operative via transducer 114 thereof. The energy thus provided through the body of the patient is also used to provide transducer 114 with energy to produce an acoustic signal related to the information thus collected by sensors 112. To this end, transducers 321 of station 130 are placed in intimate physical contact with a portion of the patient's body preferably in which biosensor 100 is implanted. Station 130 generates an acoustic interrogation signal via transducers 321 for powering biosensor 100 and for retrieving via transducers 114 sensors' 112 signals as an acoustic signal generated by transducer 114. Interrogator 115 then demodulates sensors' 112 signals and delivers the signals to recording and analyzing device 138.

40 [0133] It will be appreciated that in cases where each of sensors 112 provides information pertaining to a specific parameter, specific information from each of sensors 112 can be accessed by station 130 by providing a unique identifying code for each sensor with the acoustic interrogation signal. Such a code would be interpreted by processor 113 to command the retrieval of information from any specific sensor of sensors 112.

45 [0134] Referring now to Figures 11-13. According to another preferred embodiment of the present invention and as best illustrated in Figure 12, biosensor 100 further includes a shunt 202 for draining fluid from a portion of a patient's body, and a monitoring device 204 which is further detailed hereinbelow with respect to Figure 13. According to a preferred embodiment, monitoring device 204 is embedded within the walls of shunt 202 for non-invasively monitoring the operation of shunt 202.

50 [0135] In more detail, shunt 202 according to this embodiment of the present invention is a cerebrospinal fluid shunt and is used for draining cerebrospinal fluid from a patient's brain, when so required. Cerebrospinal fluid shunt 202 is preferably formed of medical grade synthetic resin material and presents opposed ventricular 206 and distal 208 ends

connected by a fluid passageway **205** which includes a valve **105**. When shunt **202** is implanted in a patient, ventricular end **206** is positioned in a ventricular cavity of the patient's brain and distal end **208** is positioned in an organ or body cavity remote from the ventricular cavity so as to drain fluids from the patient's brain thereto.

**[0136]** As shown in Figure 11, an appropriate site to drain the cerebrospinal fluid out of the brain may be the abdomen cavity. A further appropriate site for drainage is immediately after valve **105**, in order to make the shunt tubing as short as possible and largely simplify the implantation thereof in surgery. Such drainage is effected via a tube **214** leading from shunt **202** to the patient's abdominal cavity. Another appropriate site for draining cerebrospinal fluid out of the patient's brain may be the patient's skull, close to the spine. In this case the drainage tube is much shorter, simplifying the implantation surgery and reducing the risk to the patient. In both case, valve **105** which forms a part of, and is operable by, biosensor **100** is preferably used for alleviating intracranial pressure via shunt **202**.

**[0137]** As best illustrated in Figure 12, monitoring device **204** is preferably formed or embedded within the sidewall of shunt **202**.

**[0138]** Referring to Figure 13, monitoring device **204** preferably includes one or more pressure sensors **212** and a transducer **214** which is electrically coupled with sensors **212**. Like sensors **112**, sensors **212** can include, for example, temperature sensors, pH sensors, blood sugar sensors, blood oxygen sensors, or any other type of physiological sensing, monitoring or measuring device responsive to, for example, motion, flow, velocity, acceleration, force, strain, acoustics, moisture, osmolarity, light, turbidity, radiation, electricity, electromagnetic fields, chemicals, ionic, or enzymatic quantities or changes.

**[0139]** According to a preferred embodiment of the present invention, sensors **212** are provided for sensing the pressure of the cerebrospinal fluid in shunt passageway **205** and are preferably spaced a distance apart from one another for sensing pressure at different points within passageway **205**. Sensors **212** may be placed anywhere within shunt **202** and may include piezoelectric or piezo-resistive transducers, silicon capacitive pressure transducers, variable-resistance laminates of conductive ink, variable conductance elastomeric devices, strain gauges or similar types of pressure sensitive devices.

**[0140]** Transducer **214** is also preferably formed or embedded within the sidewall of the shunt **202** and is coupled with sensors **212** for directly or indirectly (via a processor) receiving electrical pressure signals therefrom.

**[0141]** According to this embodiment of the present invention biosensor **100** which includes monitoring device **204** is implanted in a patient as illustrated generally in Figure 11 for draining or removing cerebrospinal fluid from the patient's brain for treating hydrocephalus. Monitoring device **204** which is preferably formed within the sidewalls of shunt **202** senses or detects the pressure of the cerebrospinal fluid within shunt **202** and delivers pressure signals to transducer **214**. Preferably such monitoring is performed by sensors **212** periodically. Such periodic readings can be stored and processed within a processor for later access.

**[0142]** When it is desired to collect information from sensors **212**, station **130** (or at least transducers **321** thereof) is placed adjacent a portion of the patient's body in which biosensor **100** is implanted. As described before, station **130** generates an interrogation signal delivered through transducers **321** for concomitantly powering biosensor **100** and retrieving data therefrom via transducer **214** in a fashion similar to as described above with respect to transducer **114**. Should the data collected indicate an abnormal intracranial pressure, valve **105** of shunt **202** is opened to drain cerebrospinal fluid therethrough. To this end station **130** can be commanded to provide power for the opening of valve **105**. This operation can be controlled either manually or by a preprogrammed processor.

**[0143]** According to another preferred embodiment of the present invention and as shown in Figures 11 and 14 there is provided a transducing assembly **351** which forms a part of station **130**. In one configuration, as best seen in Figure 11, assembly **351** is incorporated into a helmet **310**. Helmet **310** includes a plurality of transducers **321**, each may serve as a transmitter, receiver or transceiver, positioned at various locations so as to provide full transmittance/reception spatial coverage of the brain volume.

**[0144]** As shown in Figure 11, a cable bundle **350** physically connects assembly **351** to multiplexer/demultiplexer **381**, which is computer controlled. Multiplexer/demultiplexer **381** serves several functions, including (i) providing a transmittance signal to transducers **321** from power amplifier **128**; (ii) conveying sensors' **112** or **212** signals from the body to signal conditioner **134**; (iii) providing a computer-controlled multiplexing for transducers **321** when used as transmitters; (iv) providing multiplexing for transducers **321** when used as receivers; and/or (v) providing decoupling between the high power transmission signals from amplifier **128** and the low amplitude signals received from transmitting assembly **118** which is located within the body, into signal conditioner **134**. It will be appreciated that multiplexer/demultiplexer **381** both isolates and routes the transmitted and received signals.

**[0145]** According to a preferred embodiment of the present invention the operation of assembly **351** included within helmet **310** is effected following pre calibration of the required location of the transducers over the helmet by, preferably, applying a method which is based on a positioning model.

**[0146]** Such a positioning model allows for an accurate placement of the extracorporeal transducers such that acoustic insonifying of the brain volume is provided at an approximately uniform level throughout.

**[0147]** In addition, to achieve such uniformity a three dimensional acoustic propagation model of the skull and brain

can also be applied.

[0148] Employment of wide beam low frequency ultrasonic transducers may be advantageous in providing an economical coverage.

[0149] In addition, focusing the acoustic beams of the extracorporeal transducers on the intrabody transducer is also advantageous because in such cases narrow beam transducers of low frequency ultrasound can be efficiently utilized.

[0150] Thus, for appropriately positioning such extracorporeal transducers, either a positioning model or a converging (in-fire) spheroidal acoustic array model with scattering can be used to provide the positional information required. With each of the transducers configuration envisaged above, a first run calibration session is employed in which communication between the helmet (extracorporeal) transducers and the intrabody transducer is tested for maximal accuracy.

[0151] The present invention is advantageous over the existing art because it employs acoustic signals which are more readily propagatable in water bodies, such as the human body, as compared to radio frequency signals.

[0152] Although the invention has been described in conjunction with specific embodiments thereof, it is evident that many alternatives, modifications and variations will be apparent to those skilled in the art. Accordingly, it is intended to embrace all such alternatives, modifications and variations that fall within the scope of the appended claims.

## Claims

1. An implantable biosensor system for monitoring a physiological condition in a patient, the biosensor system comprising:

(a) at least one sensor for sensing at least one parameter of a physiological condition and for generating electrical sensor signals representative of the physiological condition; and

(b) a processor

(c) a first acoustic activatable transducer (1) being directly or indirectly coupled with said at least one sensor, said first acoustic activatable transducer (1) being for converting a received acoustic interrogation signal from outside the patient's body into an electrical power for energizing said processor, said first acoustic activatable transducer (1) further being for converting said electrical sensor signals of said at least one sensor into acoustic signals receivable out of the patient's body, such that information pertaining to said at least one parameter of the physiological condition can be relayed outside the patient's body upon generation of an acoustic interrogation signal, said first acoustic activatable transducer (1) having dimensions, and further having a resonant wavelength which is significantly larger than said dimensions,

wherein said first acoustic activatable transducer includes:

(i) a cell member (3) having a cavity (4);

(ii) a substantially flexible piezoelectric layer (2) attached to said cell member (3), said piezoelectric layer (2) having an external surface and an internal surface, said piezoelectric layer featuring such dimensions so as to enable fluctuations thereof at its resonance frequency upon impinging of said acoustic interrogation signal; and

(iii) a first electrode attached to said external surface and a second electrode attached to said internal surface.

2. The biosensor system of claim 1, wherein the processor is coupled between said at least one sensor and said first acoustic activatable transducer, said processor being for converting said electrical sensor signals into converted electrical signals representative of the physiological condition, said processor being energized via said electrical power.

3. The biosensor system of claim 1, wherein said piezoelectric layer is of a material selected from the group consisting of PVDF and piezoceramic.

4. The biosensor system of claim 2, wherein said processor includes a conditioner and a digitizer for converting said electrical sensor signal to said converted electrical signal.

5. The biosensor system of claim 2, wherein said converted electrical signal is a digital signal.

6. The biosensor system of claim 2, wherein said processor, said first acoustic activatable transducer and said at least one sensor are co-integrated into a single biosensor device.

7. The biosensor system of claim 1, further comprising:

(d) an extracorporeal station positionable against the patient's body said extracorporeal station including an interrogation signal generator for generating said acoustic interrogation signal, said interrogation signal generator including at least one second transducer for transmitting said interrogation signal to said first acoustic activatable transducer and for receiving said receivable acoustic signals from said first acoustic activatable transducer.

- 5
8. The biosensor system of claim 2, wherein said processor includes a memory device for storing said electrical sensor signals and an analyzer for analyzing said electrical sensor signals.
- 10
9. The biosensor system of claim 8, wherein said processor includes a programmable microprocessor.
11. The biosensor system of claim 1, further comprising a shunt operable by said electrical power generated by said first acoustic activatable transducer, said shunt having a tubular sidewall and opposed ends, wherein said at least one sensor and said first acoustic activatable transducer are embedded in said shunt sidewall.
- 15
11. The biosensor system of claim 1, wherein said at least one sensor is selected from the group consisting of a pressure sensor, a temperature sensor, a pH sensor, a blood sugar sensor, a blood oxygen sensor, a motion sensor, a flow sensor, a velocity sensor, an acceleration sensor, a force sensor, a strain sensor, an acoustics sensor, a moisture sensor, an osmolarity sensor, a light sensor, a turbidity sensor, a radiation sensor, an electromagnetic field sensor, a chemical sensor, an ionic sensor, and an enzymatic sensor.
- 20
12. The biosensor system of claim 1, wherein said first acoustic activatable transducer is capable of transmitting an identification code identifying said transducer.

25 **Patentansprüche**

1. Implantierbares Biosensorsystem zum Überwachen eines physiologischen Zustands in einem Patienten, welches Biosensorsystem aufweist:

- 30
- (a) zumindest einen Sensor zum Erfassen zumindest eines Parameters eines physiologischen Zustands und zum Erzeugen elektrischer Sensorsignale, die für den physiologischen Zustand repräsentativ sind;
- (b) einen Prozessor und
- (c) einen ersten akustischen aktivierbaren Wandler (1), der direkt oder indirekt mit dem zumindest einen Sensor gekoppelt ist, welcher erste akustische aktivierbare Wandler (1) vorgesehen ist zum Umwandeln eines empfangenen akustischen Abfragesignals von außerhalb des Körpers des Patienten in eine elektrische Energie zum Zuführen von Energie zu dem Prozessor, welcher erste akustische aktivierbare Wandler (1) weiterhin vorgesehen ist zum Umwandeln der elektrischen Sensorsignale des zumindest einen Sensors in akustische Signale, die aus dem Körper des Patienten heraus empfangbar sind, derart, dass Informationen, die sich auf den zumindest einen Parameter des physiologischen Zustands beziehen, bei Erzeugung eines akustischen Abfragesignals außerhalb des Körpers des Patienten weitergeleitet werden können, welcher erste akustische aktivierbare Wandler (1) Abmessungen und weiterhin eine Resonanzwellenlänge, die beträchtlich größer als diese Abmessungen ist, hat,
- 35
- 40

wobei der erste akustische aktivierbare Wandler enthält:

- 45
- (i) ein Zellenteil (3) mit einem Hohlraum (4) ;
- (ii) eine wesentlich flexible piezoelektrische Schicht (2), die an dem Zellenteil (3) angebracht ist, welche piezoelektrische Schicht (2) eine äußere Oberfläche und eine innere Oberfläche hat, welche piezoelektrische Schicht solche Abmessungen aufweist, um Schwankungen hiervon bei ihrer Resonanzfrequenz zu ermöglichen bei Auftreffen des akustischen Abfragesignals; und
- (iii) eine erste Elektrode, die an der äußeren Oberfläche angebracht ist, und eine zweite Elektrode, die an der inneren Oberfläche angebracht ist.
- 50

2. Biosensorsystem nach Anspruch 1, bei dem der Prozessor zwischen den zumindest einen Sensor und den ersten akustischen aktivierbaren Wandler gekoppelt ist, welcher Prozessor vorgesehen ist zum Umwandeln der elektrischen Sensorsignale in umgewandelte elektrische Signale, die für den physiologischen Zustand repräsentativ sind, welcher Prozessor über die elektrische Energie erregt wird.
- 55

## EP 1 050 264 B1

3. Biosensorsystem nach Anspruch 1, bei dem die piezoelektrische Schicht aus einem Material besteht, das aus der Gruppe bestehend aus PVDF und Piezokeramik ausgewählt ist.
- 5 4. Biosensorsystem nach Anspruch 2, bei dem der Prozessor eine Vorbehandlungsvorrichtung und einen Digitalisierer zum Umwandeln des elektrischen Sensorsignals in das umgewandelte elektrische Signal enthält.
5. Biosensorsystem nach Anspruch 2, bei dem das umgewandelte elektrische Signal ein digitales Signal ist.
- 10 6. Biosensorsystem nach Anspruch 2, bei dem der Prozessor, der erste akustische aktivierbare Wandler und der zumindest eine Sensor miteinander in eine einzige Biosensorvorrichtung integriert sind.
7. Biosensorsystem nach Anspruch 1, weiterhin aufweisend:
- 15 (d) eine außerhalb des Körpers befindliche Station, die an dem Körper des Patienten positionierbar ist, welche außerhalb des Körpers befindliche Station einen Abfragesignalgenerator zum Erzeugen des akustischen Abfragesignals enthält, welcher Abfragesignalgenerator zumindest einen zweiten Wandler zum Übertragen des Abfragesignals zu dem ersten akustischen aktivierbaren Wandler und zum Empfangen der empfangbaren akustischen Signale von dem ersten akustischen aktivierbaren Wandler enthält.
- 20 8. Biosensorsystem nach Anspruch 2, bei dem der Prozessor eine Speichervorrichtung zum Speichern der elektrischen Sensorsignale und eine Analysevorrichtung zum Analysieren der elektrischen Sensorsignale enthält.
9. Biosensorsystem nach Anspruch 8, bei dem der Prozessor einen programmierbaren Mikroprozessor enthält.
- 25 10. Biosensorsystem nach Anspruch 1, weiterhin aufweisend einen Shunt, der durch die von dem ersten akustischen aktivierbaren Wandler erzeugte elektrische Leistung betätigbar ist, welcher Shunt eine rohrförmige Seitenwand und entgegengesetzte Enden hat, wobei der zumindest eine Sensor und der erste akustische aktivierbare Wandler in der Seitenwand des Shunts eingebettet sind.
- 30 11. Biosensorsystem nach Anspruch 1, bei dem der zumindest eine Sensor ausgewählt ist aus der Gruppe bestehend aus einem Drucksensor, einem Temperatursensor, einem pH-Sensor, einem Blutzuckersensor, einem Blutsauerstoffsensor, einem Bewegungssensor, einem Strömungssensor, einem Geschwindigkeitssensor, einem Beschleunigungssensor, einem Kraftsensor, einem Beanspruchungssensor, einem akustischen Sensor, einem Feuchtigkeitssensor, einem Osmolaritätssensor, einem Lichtsensor, einem Trübungssensor, einem Strahlungssensor, einem elektromagnetischen Feldsensor, einem chemischen Sensor, einem ionischen Sensor und einem enzymatischen Sensor.
- 35 12. Biosensorsystem nach Anspruch 1, bei dem der erste akustische aktivierbare Wandler in der Lage ist, einen den Wandler identifizierenden Identifikationscode zu übertragen.
- 40

### Revendications

- 45 1. Système de biocapteur implantable pour surveiller une condition physiologique au niveau d'un patient, le système de biocapteur comprenant :
- (a) au moins un capteur pour détecter au moins un paramètre d'une condition physiologique et pour générer des signaux de capteur électriques représentatifs de la condition physiologique;
- (b) un processeur ; et
- 50 (c) un premier transducteur activable acoustique (1) qui est directement ou indirectement couplé avec ledit au moins un capteur, ledit premier transducteur activable acoustique (1) étant pour convertir un signal d'interrogation acoustique reçu depuis l'extérieur du corps du patient selon une puissance électrique pour activer ledit processeur, ledit premier transducteur activable acoustique (1) étant en outre pour convertir lesdits signaux de capteur électriques dudit au moins un capteur selon des signaux acoustiques pouvant être reçus à partir du corps du patient, de telle sorte qu'une information concernant ledit au moins un paramètre de la condition physiologique puisse être relayée à l'extérieur du corps du patient suite à la génération d'un signal d'interrogation acoustique, ledit premier transducteur activable acoustique (1) présentant des dimensions, et présentant en outre une
- 55 longueur d'onde résonante qui est significativement plus grande que lesdites dimensions,

dans lequel ledit premier transducteur activable acoustique inclut :

- (i) un élément de cellule (3) comportant une cavité (4) ;
- (ii) une couche piézoélectrique substantiellement flexible (2) liée audit élément de cellule (3), ladite couche piézoélectrique (2) comportant une surface externe et une surface interne, ladite couche piézoélectrique caractérisant lesdites dimensions de manière à permettre leurs fluctuations à sa fréquence de résonance suite à l'arrivée en incidence dudit signal d'interrogation acoustique ; et
- (iii) une première électrode liée sur ladite surface externe et une seconde électrode liée sur ladite surface interne.

5

10 **2.** Système de biocapteur selon la revendication 1, dans lequel le processeur est couplé entre ledit au moins un capteur et ledit premier transducteur activable acoustique, ledit processeur étant pour convertir lesdits signaux de capteur électriques selon des signaux électriques convertis représentatifs de la condition physiologique, ledit processeur étant alimenté via ladite puissance électrique.

15 **3.** Système de biocapteur selon la revendication 1, dans lequel ladite couche piézoélectrique est en un matériau choisi parmi le groupe constitué par du PVDF et une piézocéramique.

**4.** Système de biocapteur selon la revendication 2, dans lequel ledit processeur inclut un conditionneur et un numériseur pour convertir ledit signal de capteur électrique selon ledit signal électrique converti.

20

**5.** Système de biocapteur selon la revendication 2, dans lequel ledit signal électrique converti est un signal numérique.

**6.** Système de biocapteur selon la revendication 2, dans lequel ledit processeur, ledit premier transducteur activable acoustique et ledit au moins un capteur sont co-intégrés selon un unique dispositif de biocapteur.

25

**7.** Système de biocapteur selon la revendication 1, comprenant en outre :

- (d) une station extracorporelle qui peut être positionnée contre le corps du patient, ladite station extracorporelle incluant un générateur de signal d'interrogation pour générer ledit signal d'interrogation acoustique, ledit générateur de signal d'interrogation incluant au moins un second transducteur pour émettre ledit signal d'interrogation sur ledit premier transducteur activable acoustique et pour recevoir lesdits signaux acoustiques recevables depuis ledit premier transducteur activable acoustique.

30

**8.** Système de biocapteur selon la revendication 2, dans lequel ledit processeur inclut un dispositif de mémoire pour stocker lesdits signaux de capteur électriques et un analyseur pour analyser lesdits signaux de capteur électriques.

35

**9.** Système de biocapteur selon la revendication 8, dans lequel ledit processeur inclut un microprocesseur programmable.

**10.** Système de biocapteur selon la revendication 1, comprenant en outre un shunt actionnable par ladite puissance électrique générée par ledit premier transducteur activable acoustique, ledit shunt comportant une paroi latérale tubulaire et des extrémités opposées, dans lequel ledit au moins un capteur et ledit premier transducteur activable acoustique sont noyés dans ladite paroi latérale de shunt.

40

**11.** Système de biocapteur selon la revendication 1, dans lequel ledit au moins un capteur est choisi parmi le groupe constitué par un capteur de pression, un capteur de température, un capteur de pH, un capteur de sucre dans le sang, un capteur d'oxygène du sang, un capteur de mouvement, un capteur de circulation, un capteur de vitesse, un capteur d'accélération, un capteur de force, un capteur de contrainte, un capteur acoustique, un capteur d'humidité, un capteur d'osmolarité, un capteur de lumière, un capteur de turbidité, un capteur de rayonnement; un capteur de champ électromagnétique, un capteur chimique, un capteur ionique et un capteur enzymatique.

50

**12.** Système de biocapteur selon la revendication 1, dans lequel ledit premier transducteur activable acoustique peut émettre un code d'identification qui identifie ledit transducteur.

55

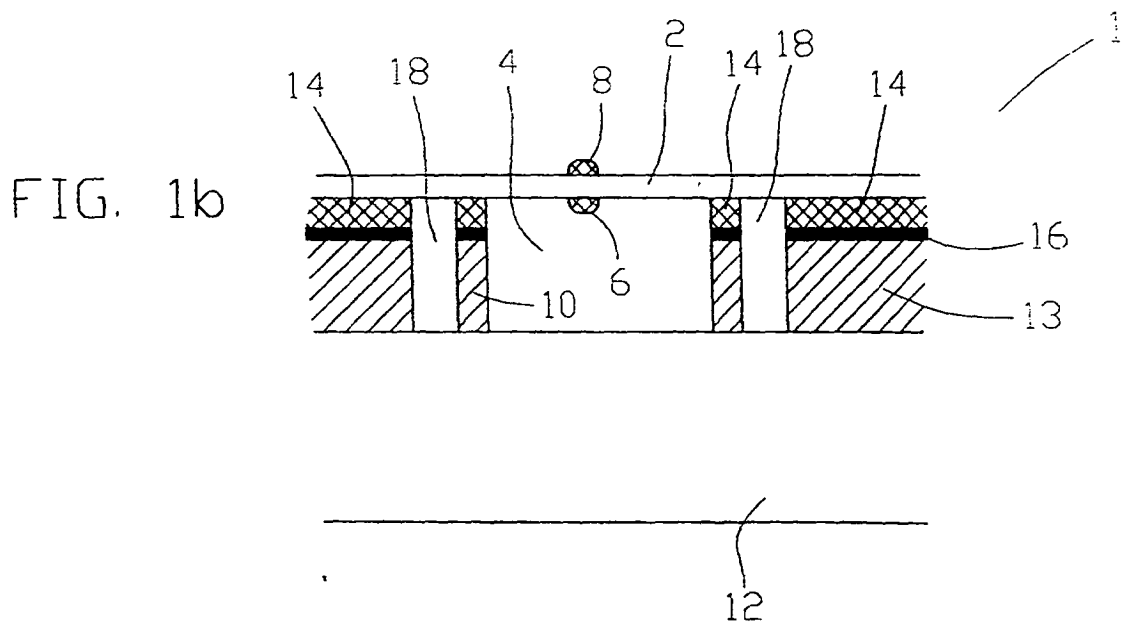
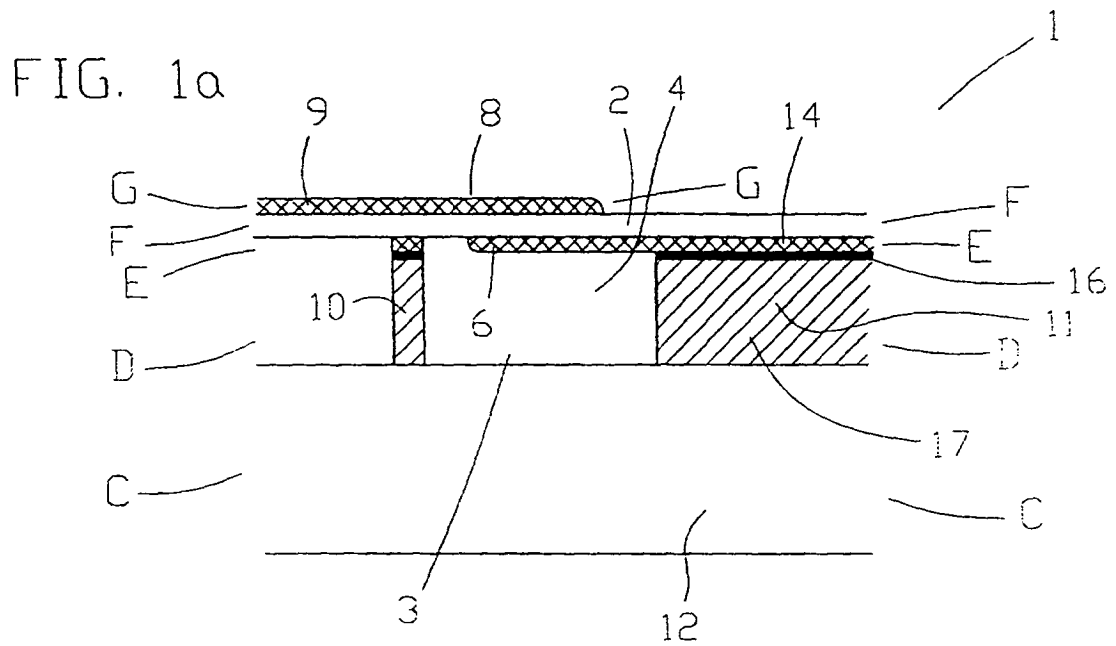

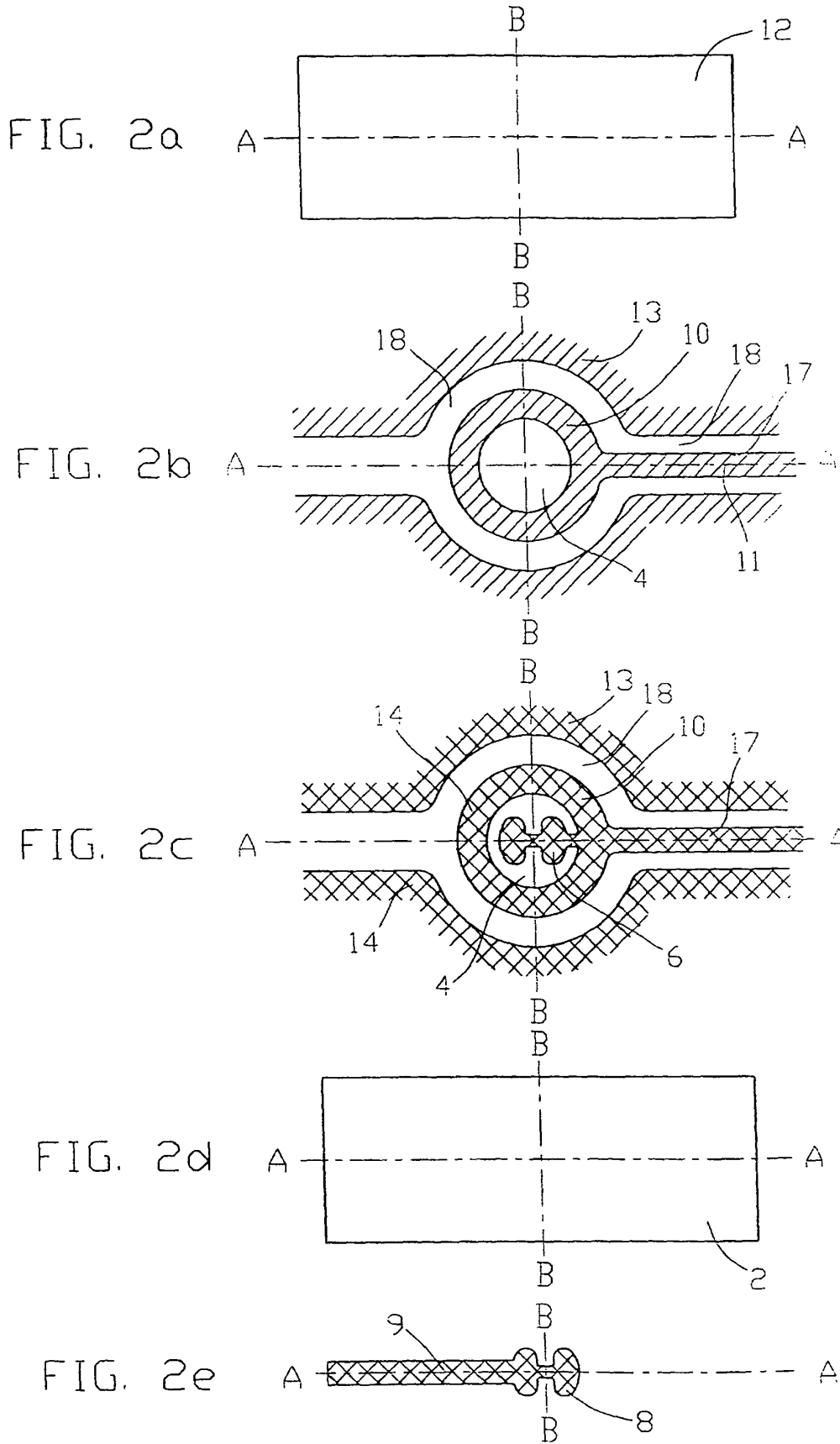

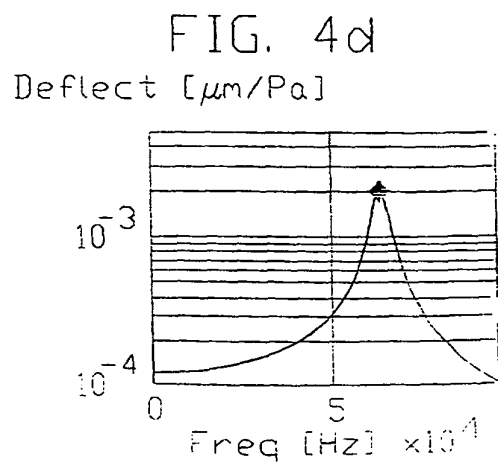
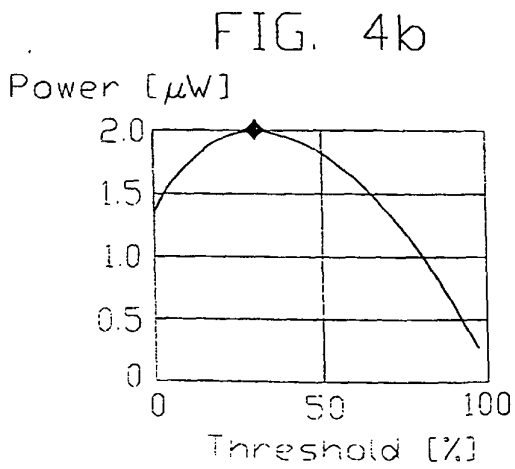
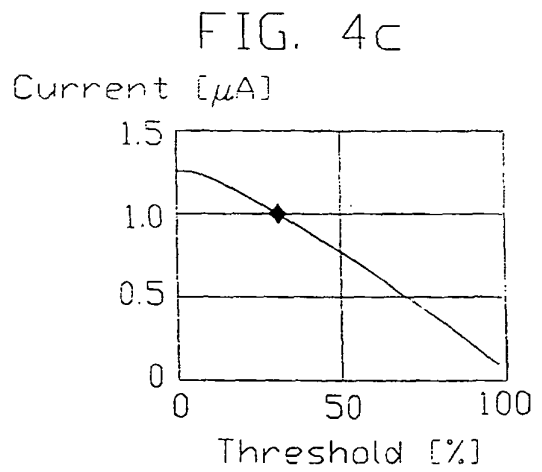
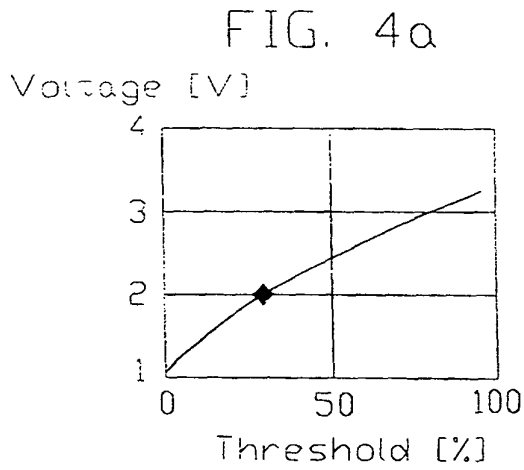
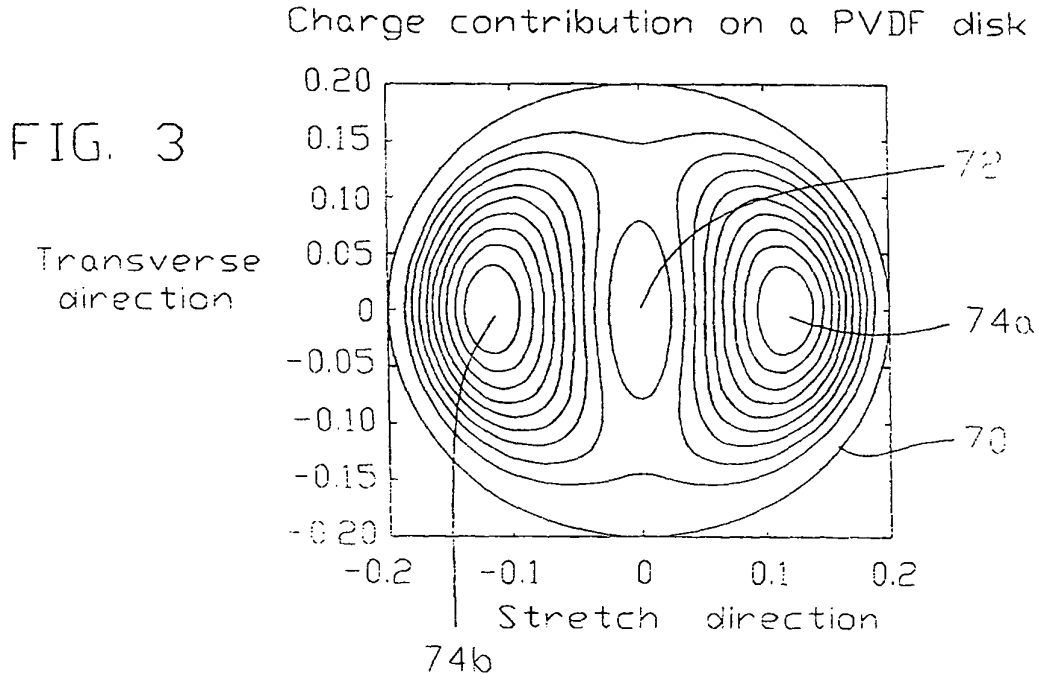

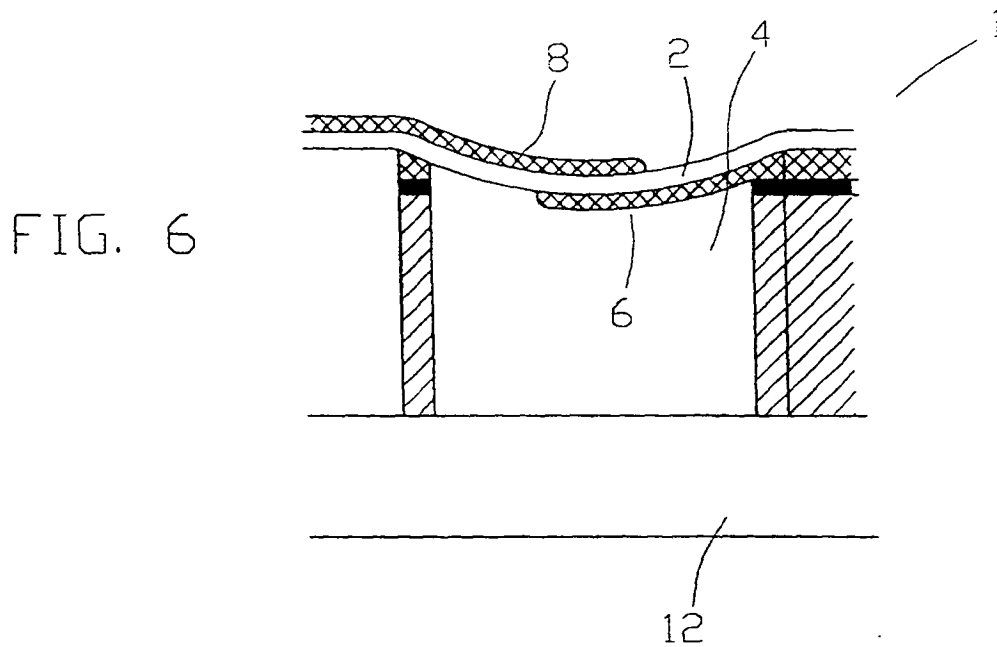
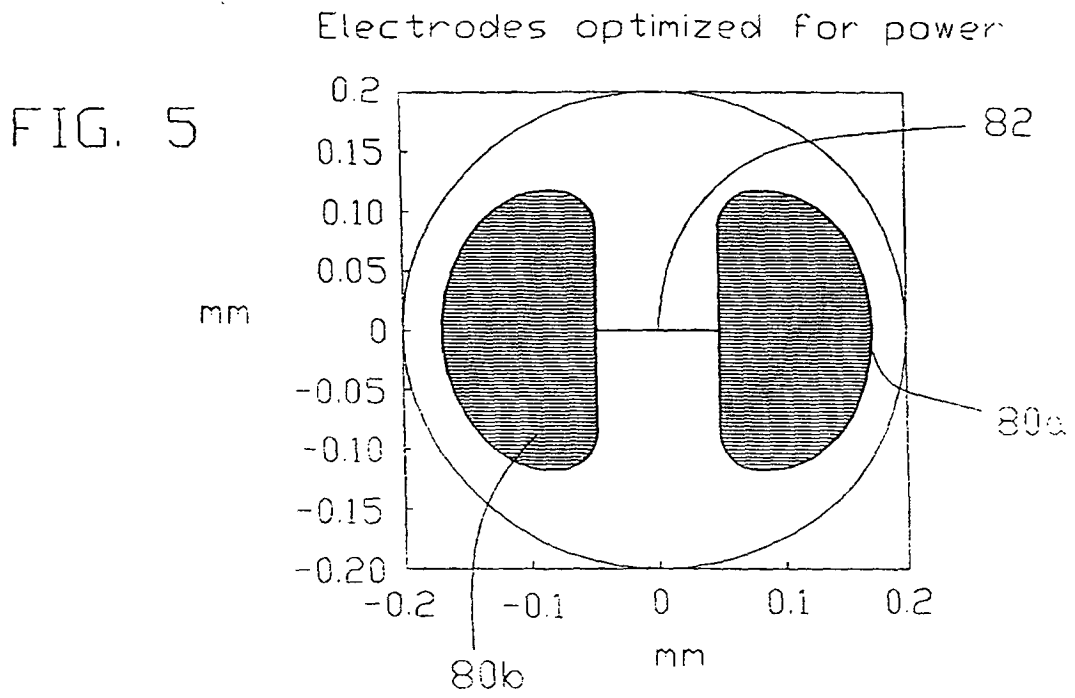

FIG. 7a

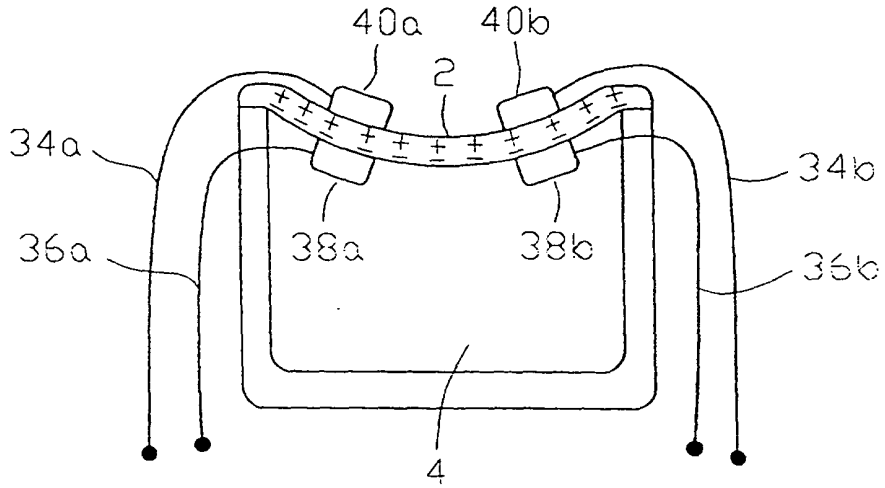

FIG. 7b

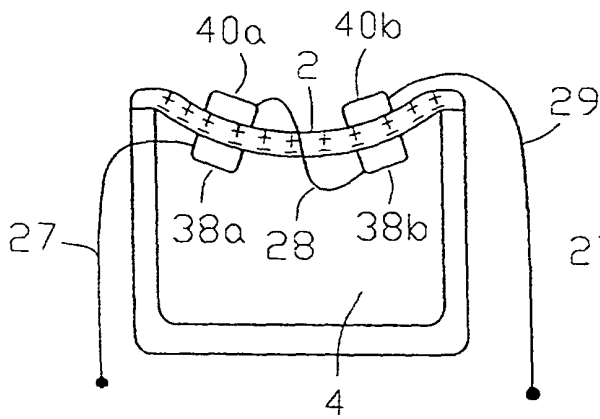

FIG. 7c

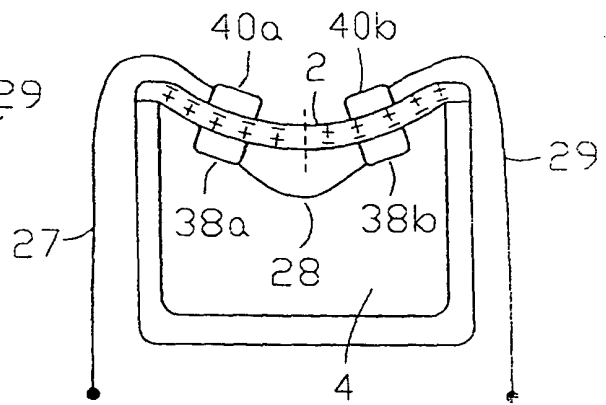

FIG. 7d

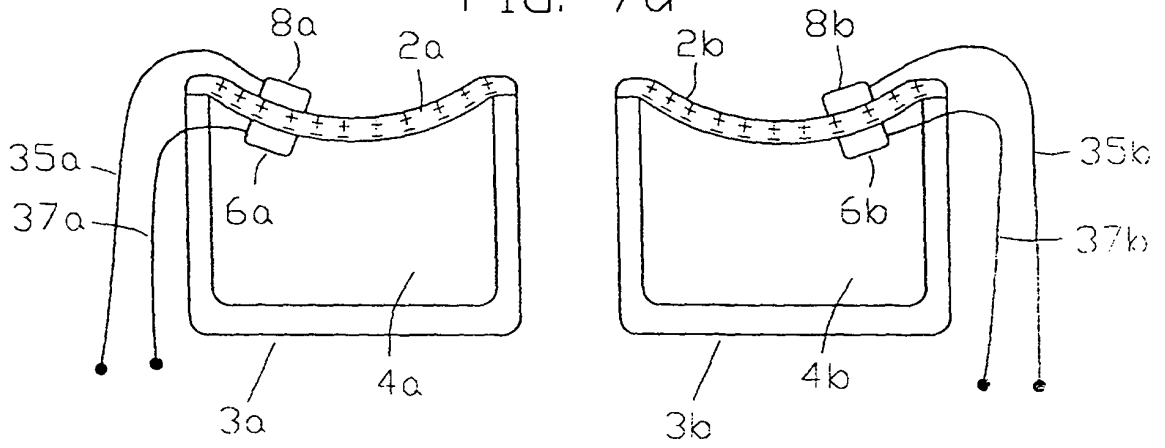

FIG. 7e

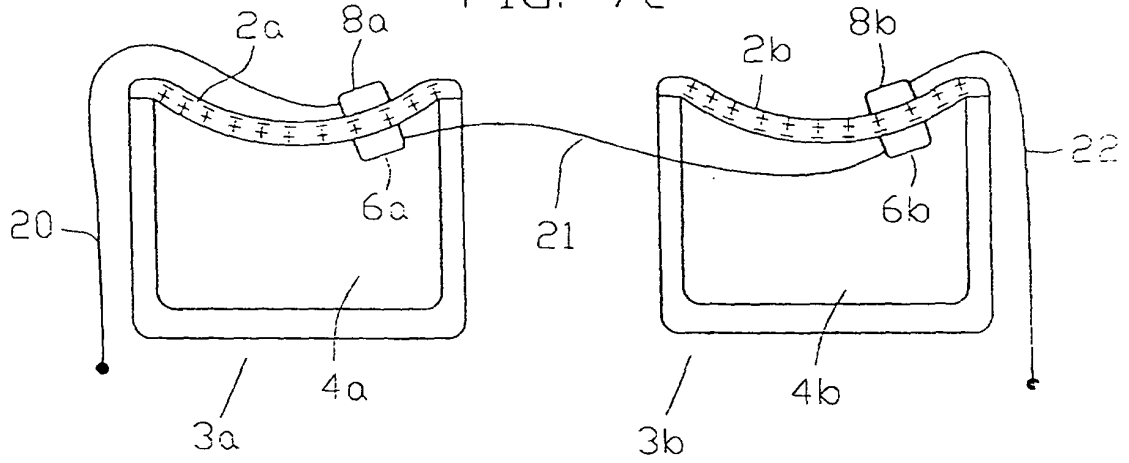

FIG. 7f

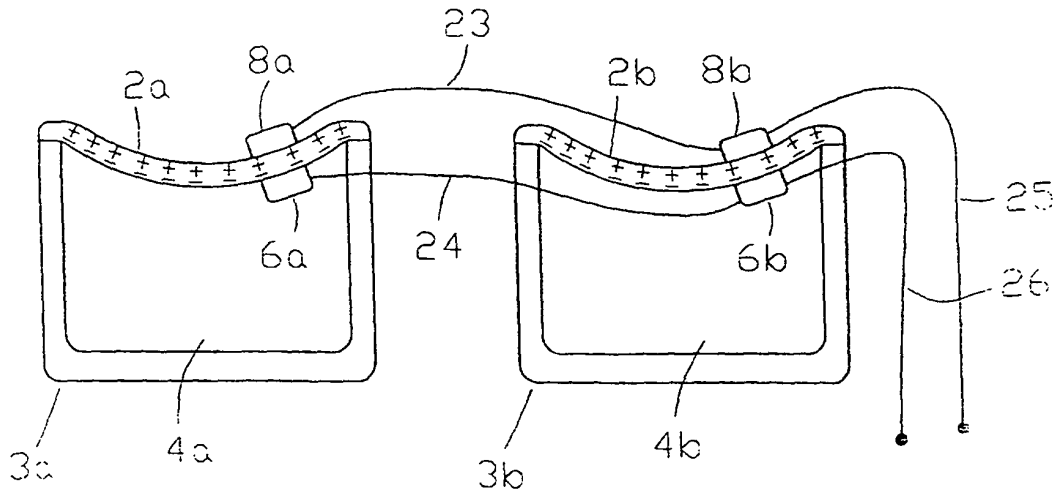

FIG. 8

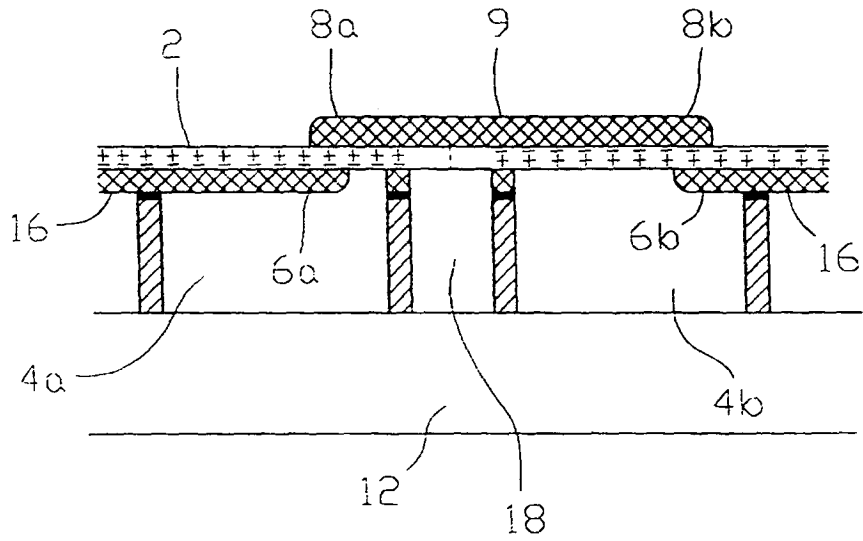
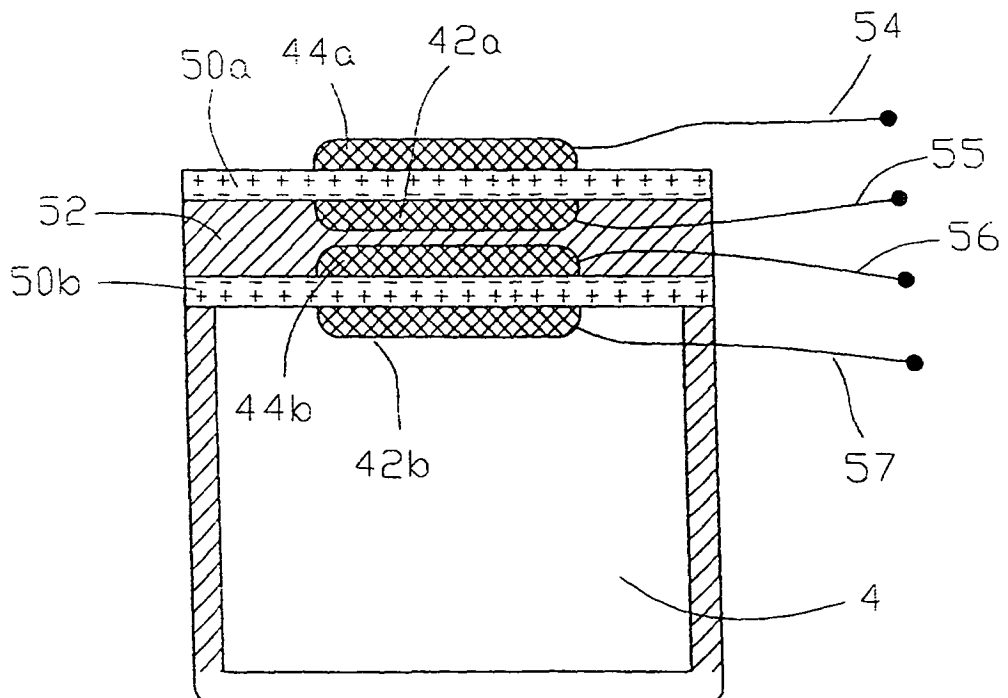

FIG. 9



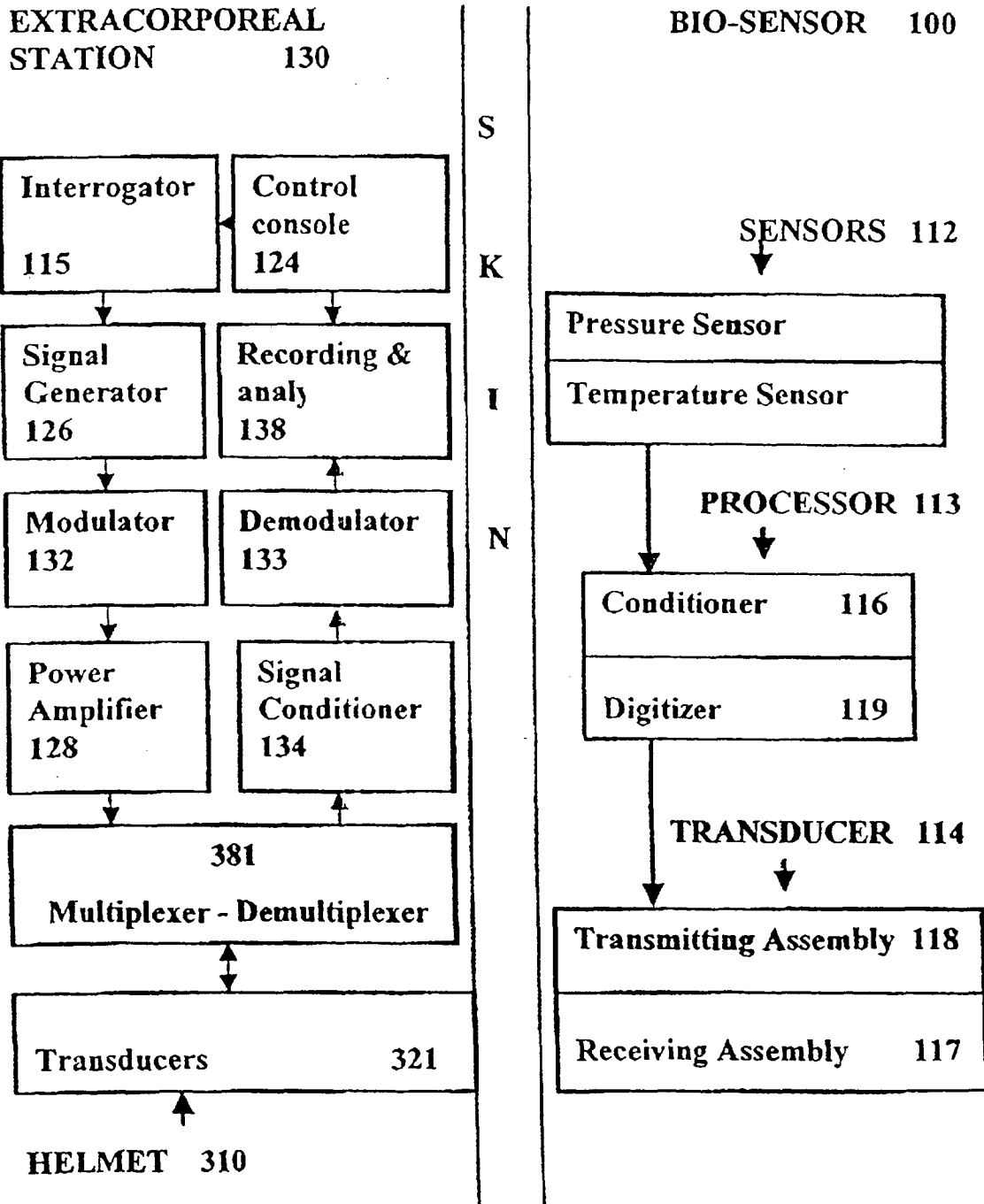
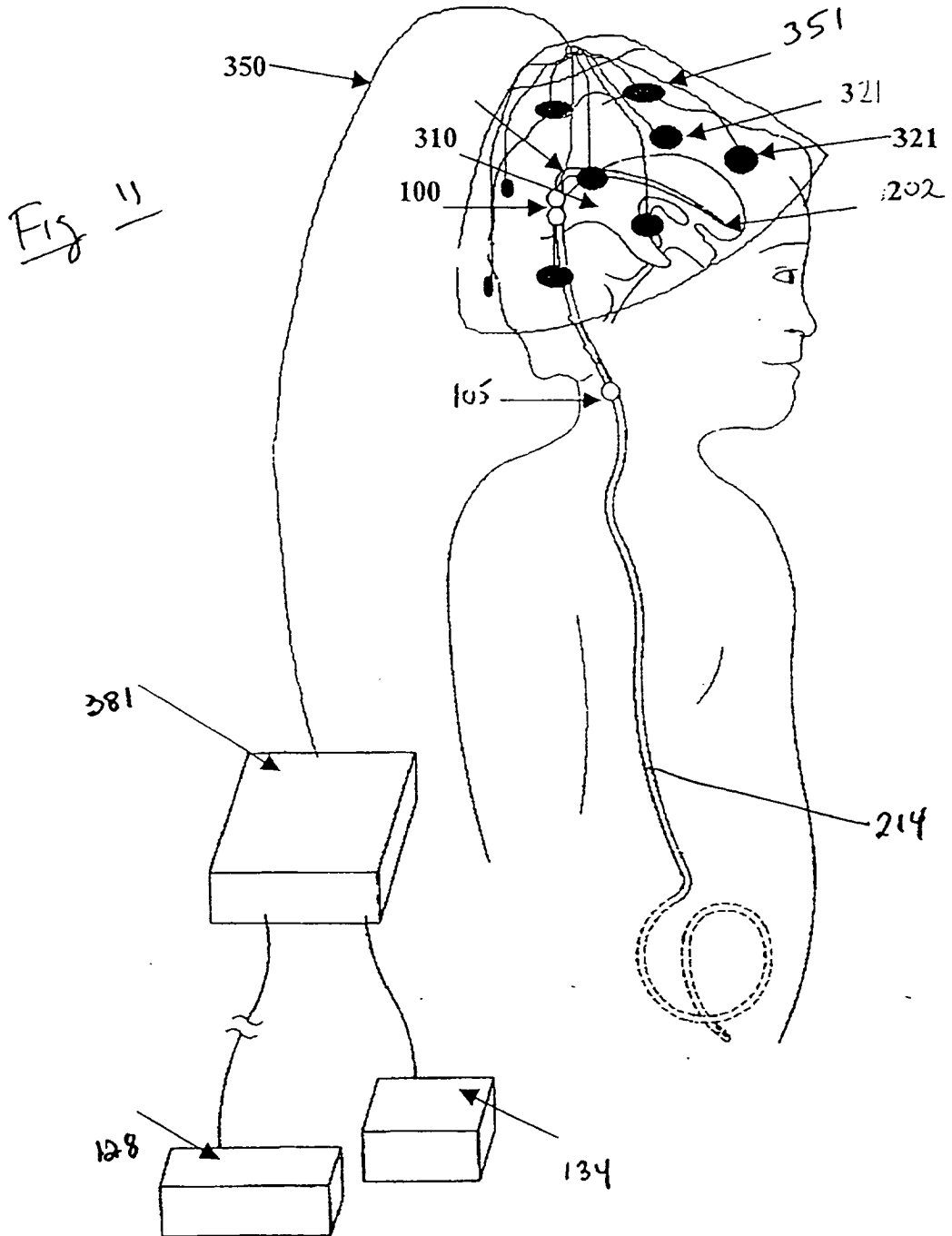

Fig 10



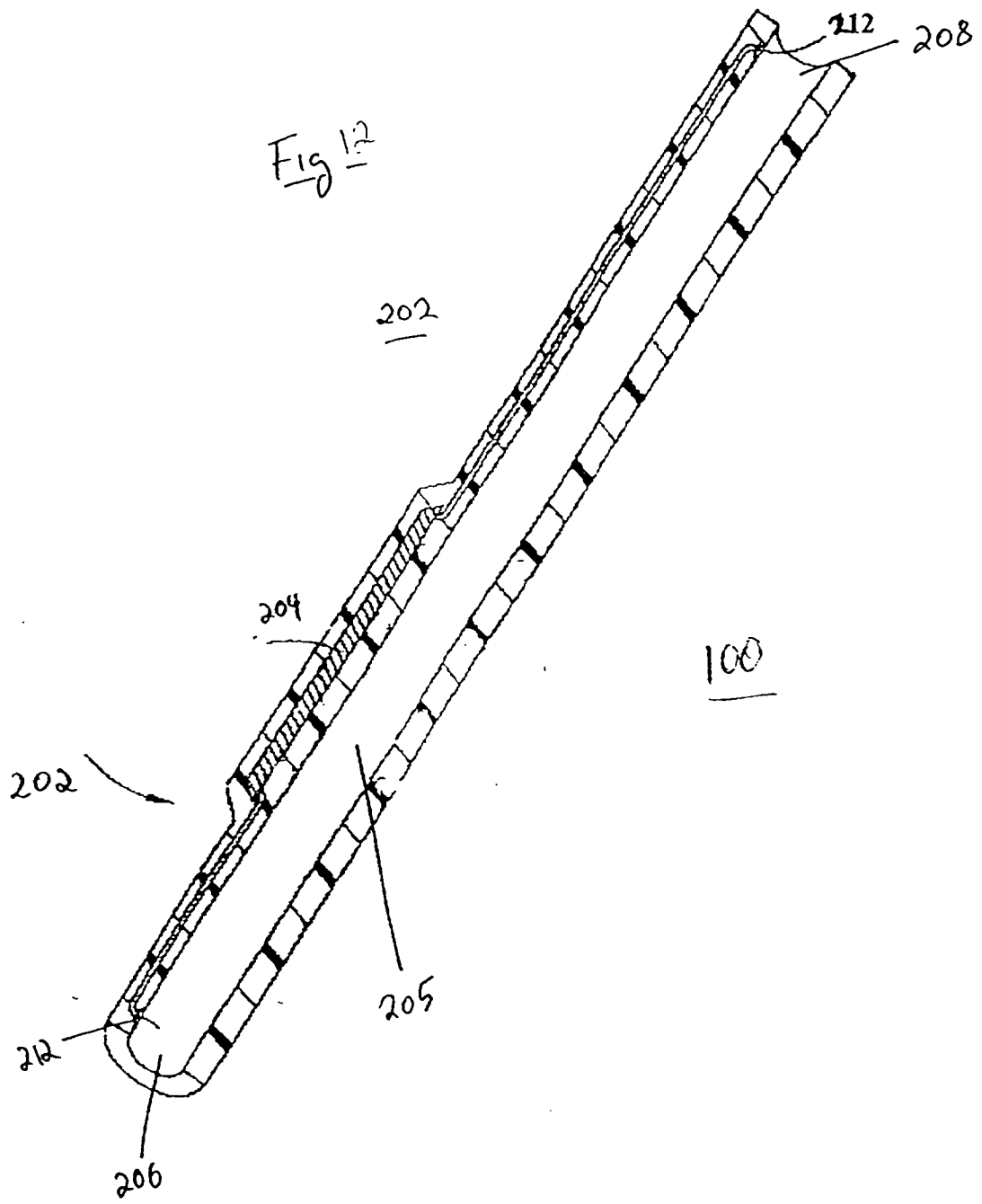
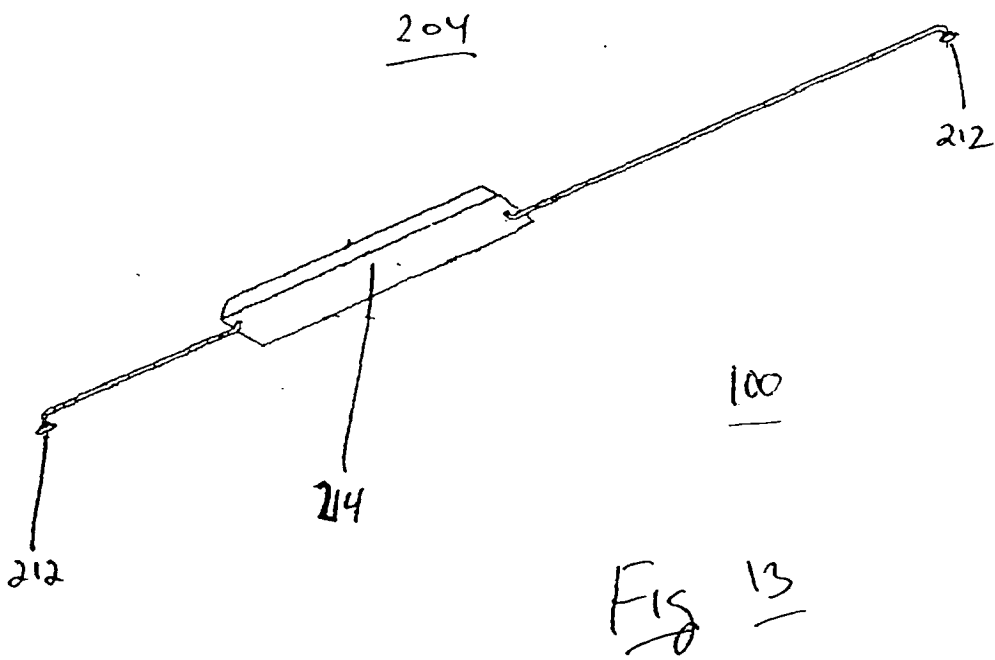

Fig 12



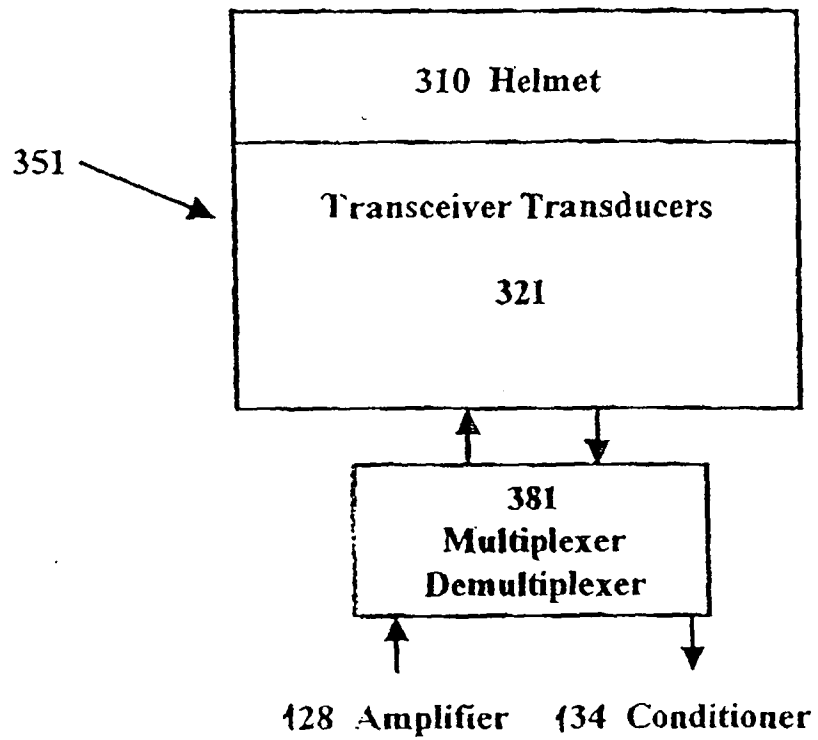

Fig 14

**REFERENCES CITED IN THE DESCRIPTION**

*This list of references cited by the applicant is for the reader's convenience only. It does not form part of the European patent document. Even though great care has been taken in compiling the references, errors or omissions cannot be excluded and the EPO disclaims all liability in this regard.*

**Patent documents cited in the description**

- US 4677985 A [0003]
- US 4471786 A [0004]
- US 3943915 A [0005]
- US 4593703 A [0005]
- US 5704352 A [0011]
- WO 9733513 A [0013]
- US 000553 A [0045] [0051] [0053] [0054] [0074] [0079] [0082] [0088] [0098] [0099]
- US 161658 A [0115]
- US 5619997 A [0124]

**Non-patent literature cited in the description**

- **ZHENGNIAN TANG ; BRIAN SMITH ; JOHN H. SCHILD ; P. HUNTER PECKHAM.** Data Transmission from an Implantable Biotelemeter by Load-Shift Keying Using Circuit Configuration Modulator. *IEEE Transactions on Biomedical Engineering*, May 1995, vol. 42 (5), 524-528 [0127]

专利名称(译)	植入式声学生物传感系统和方法		
公开(公告)号	<a href="#">EP1050264B1</a>	公开(公告)日	2008-03-12
申请号	EP2000109256	申请日	2000-04-28
[标]申请(专利权)人(译)	REMON医疗TECH		
申请(专利权)人(译)	REMON MEDICAL TECHNOLOGIES LTD.		
当前申请(专利权)人(译)	REMON MEDICAL TECHNOLOGIES LTD.		
[标]发明人	PORAT YARIV PENNER AVI DORON EYAL		
发明人	PORAT, YARIV PENNER, AVI DORON, EYAL		
IPC分类号	A61B5/00 A61B5/03 A61M27/00 A61B5/01 A61B5/0215 A61B5/026 G01F1/36 G01F1/72 H01L41/113 H04R3/00 H04R17/00		
CPC分类号	A61B5/02158 A61B5/0031 A61B5/026 A61B5/031 A61B5/413 A61B2562/028 A61M2205/3523 G01F1/36 G01F1/72 H01L41/1138 H04R17/00		
优先权	09/303644 1999-05-03 US		
其他公开文献	EP1050264A1		
外部链接	<a href="#">Espacenet</a>		

摘要(译)

提供了一种用于监测和任选地减轻患者生理状况的可植入生物传感器系统，其包括 (a) 至少一个传感器，用于感测生理状况的至少一个参数并且用于产生代表生理状况的电传感器信号；(b) 第一声可激活换能器直接或间接地与至少一个传感器耦合，第一声可激活换能器用于将接收到的声学询问信号从患者体外转换成电能以激励处理器，第一声学可激活换能器还用于将至少一个传感器的电传感器信号转换成可接收到患者体外的声学信号，使得关于生理状况的至少一个参数的信息可以在生成时传递到患者体外。声学询问信号。

$$(\gamma^2 - \gamma^2)(\gamma^2 + \gamma^2) \Psi - \frac{2(1 - \nu^2)}{2Qh^3} P + \frac{3iZ_0(1 - \nu^2)}{2Qh^3} \Psi = 0$$