



- (51) International Patent Classification:
G01S 11/12 (2006.01) A47C 27/00 (2006.01)
- (21) International Application Number:
PCT/US2014/047157
- (22) International Filing Date:
18 July 2014 (18.07.2014)
- (25) Filing Language: English
- (26) Publication Language: English
- (30) Priority Data:
13/945,554 18 July 2013 (18.07.2013) US
- (71) Applicant: BAM LABS, INC. [US/US]; 900 East Hamilton, Suite 525, Campbell, California 95008 (US).
- (72) Inventors: YOUNG, Steven J.; c/o BAM LABS, INC., 900 East Hamilton, Suite 525, Campbell, California 95008 (US). HEWITT, Carl; c/o BAM LABS, INC., 900 East Hamilton, Suite 525, Campbell, California 95008 (US). LUCKOW, Al; c/o BAM LABS, INC., 900 East Hamilton, Suite 525, Campbell, California 95008 (US).

(74) Agents: NESTL, Francine B. et al.; Young Basile Hanlon & Macfarlane P.C., 3001 West Big Beaver Road, Suite 624, Troy, Michigan 48084-3107 (US).

(81) Designated States (unless otherwise indicated, for every kind of national protection available): AE, AG, AL, AM, AO, AT, AU, AZ, BA, BB, BG, BH, BN, BR, BW, BY, BZ, CA, CH, CL, CN, CO, CR, CU, CZ, DE, DK, DM, DO, DZ, EC, EE, EG, ES, FI, GB, GD, GE, GH, GM, GT, HN, HR, HU, ID, IL, IN, IR, IS, JP, KE, KG, KN, KP, KR, KZ, LA, LC, LK, LR, LS, LT, LU, LY, MA, MD, ME, MG, MK, MN, MW, MX, MY, MZ, NA, NG, NI, NO, NZ, OM, PA, PE, PG, PH, PL, PT, QA, RO, RS, RU, RW, SA, SC, SD, SE, SG, SK, SL, SM, ST, SV, SY, TH, TJ, TM, TN, TR, TT, TZ, UA, UG, US, UZ, VC, VN, ZA, ZM, ZW.

(84) Designated States (unless otherwise indicated, for every kind of regional protection available): ARIPO (BW, GH, GM, KE, LR, LS, MW, MZ, NA, RW, SD, SL, SZ, TZ, UG, ZM, ZW), Eurasian (AM, AZ, BY, KG, KZ, RU, TJ, TM), European (AL, AT, BE, BG, CH, CY, CZ, DE, DK, EE, ES, FI, FR, GB, GR, HR, HU, IE, IS, IT, LT, LU, LV,

[Continued on next page]

(54) Title: DEVICE AND METHOD OF MONITORING A POSITION AND PREDICTING AN EXIT OF A SUBJECT ON OR FROM A SUBSTRATE

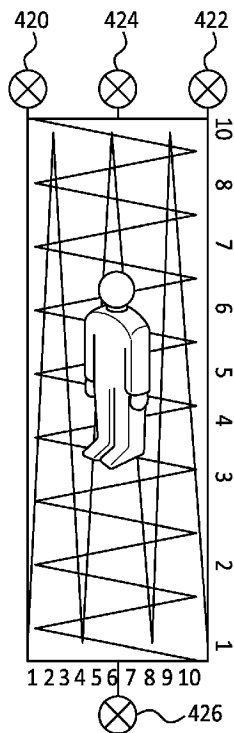

Figure 5A

(57) Abstract: Methods and devices for monitoring the position of a subject are disclosed. One such method includes sensing pressure waves generated by the subject moving on a divided bladder comprising interleaved portions, generating signals indicative of the pressure waves for each of the interleaved portions, and sending the signals to a processor. The method further includes determining the position of the subject based on the difference between the signals from each of the interleaved portions and generating a pattern for the subject. The pattern includes the presence and/or position of the subject over time. The method further includes predicting an action such as an exit of the subject from the divided bladder based on comparing a current pattern for the subject to previous patterns for the subject.

WO 2015/009999 A1



MC, MK, MT, NL, NO, PL, PT, RO, RS, SE, SI, SK,
SM, TR), OAPI (BF, BJ, CF, CG, CI, CM, GA, GN, GQ,
GW, KM, ML, MR, NE, SN, TD, TG).

— before the expiration of the time limit for amending the
claims and to be republished in the event of receipt of
amendments (Rule 48.2(h))

Published:

— with international search report (Art. 21(3))

**DEVICE AND METHOD OF MONITORING A POSITION AND
PREDICTING AN EXIT OF A SUBJECT ON OR FROM A SUBSTRATE**

FIELD OF THE INVENTION

[0001] The present disclosure pertains in general to a monitoring system for monitoring the presence, position, and pattern of movement of a subject on a substrate such as a mattress, and for predicting exit of a subject from the substrate.

BACKGROUND

[0002] Monitoring a condition of a subject, such as a subject at rest on a mattress, can include monitoring vital signs, such as heart and respiration rates. Some monitoring systems can include expensive and cumbersome equipment, such as an electrocardiogram (EKG), a ballistocardiograph (BCG), a piezoelectric film, or an array of sensors. EKGs, for example, typically necessitate attaching electrodes in substantially direct contact with a subject, while BCGs rely on large, heavy, unaesthetic force-measuring platforms.

[0003] In some implementations, monitoring a condition of a subject can include monitoring the presence or absence of a subject, for example, the presence or absence of a subject on a mattress. However, in addition to being expensive and cumbersome, monitoring systems can be unable to accurately predict when a subject is about to change condition, for example, when a presence condition is about to change from present to absent based on the subject exiting the mattress.

SUMMARY

[0004] Methods and devices for monitoring a position of a subject on a substrate are disclosed. One such method includes sensing incident pressure waves generated by the subject moving on a divided bladder comprising interleaved portions with at least one sensor in fluid communication with a respective portion of the divided bladder, generating signals indicative of the incident pressure waves for each of the interleaved portions of the bladder and sending the signals to a processor, determining a position of the subject on the divided bladder based on a difference between the signals from each of the interleaved portions and generating a position pattern for the subject over a period of time.

[0005] Another method includes sensing, with one or more sensors, incident pressure waves generated by the subject moving on a divided bladder comprising interleaved portions wherein the one or more sensors are in fluid communication with the bladder; generating signals indicative of the incident pressure waves for each of the interleaved portions of the bladder and sending the signals to a processor; determining the presence of the subject on the divided bladder based on the magnitude of the signals from each of the interleaved portions; determining the position of the subject on the divided bladder based on the difference between the signals from each of the interleaved portions; generating a pattern for the subject, wherein the pattern includes the presence and position of the subject over time; and predicting an exit of the subject from the divided bladder based on comparing a current pattern for the subject to previous patterns for the subject.

[0006] In another embodiment, a non-intrusive monitoring device for monitoring the position of a subject is disclosed. The device includes a divided bladder comprising interleaved portions; one or more sensors in fluid communication with the interleaved portions of the divided bladder wherein the one or more sensors are configured to generate signals in response to pressure variations resulting from movement of a subject on the divided bladder; and a processor. The processor is configured to: receive signals from the one or more sensors for each of the interleaved portions; determine the subject's presence on the divided bladder based on the magnitude of the signals from each of the interleaved portions; determine the subject's position on the divided bladder based on the difference between the signals from each of the interleaved portions; generate a pattern for the subject, wherein the pattern includes the subject's presence and subject's position over time; and predict an exit of the subject from the divided bladder based on comparing a current pattern for the subject to previous patterns for the subject.

[0007] In another embodiment, a device for monitoring the position of a subject on a substrate is disclosed. The device includes: a sensing unit having a divided bladder comprising interleaved portions configured to be placed under the substrate on which the subject lies and one or more sensors in fluid communication with the interleaved portions, wherein the one or more sensors are configured to sense pressure variations within the divided bladder generated by movement of the subject and to generate signals indicative of the pressure variations; a processor

configured to receive the signals and to determine and generate output indicative of the subject's position based on the difference between the signals from each of the interleaved portions; and an external device configured to display the output.

BRIEF DESCRIPTION OF THE DRAWINGS

[0008] The description makes reference to the accompanying drawings, wherein like reference numerals refer to like parts throughout the several views, and wherein:

[0009] Figure 1 is a diagram of a computing and communications system in accordance with implementations of this disclosure;

[0010] Figure 2 is a diagram of an example computing and communication device in accordance with implementations of this disclosure;

[0011] Figure 3 shows an example of a non-intrusive monitoring apparatus for monitoring a condition of a subject in accordance with implementations of this disclosure;

[0012] Figures 4A and 4B show a top view of a pair of seamed bladders for monitoring a position of a subject using the apparatus of Figure 3 and graphical representations of pressure differentials along the seamed bladders by subject position;

[0013] Figures 5A-5C illustrate the non-intrusive monitoring apparatus used in monitoring a subject's position;

[0014] Figure 6 illustrates another embodiment of a seamed bladder for monitoring a position of a subject using the apparatus of Figure 3;

[0015] Figure 7 is a representative system architecture for monitoring the position of a subject in accordance with implementations of this disclosure; and

[0016] Figure 8 is a method of monitoring the position of a subject in accordance with implementations of this disclosure.

DETAILED DESCRIPTION

[0017] Method and devices for non-intrusive monitoring of the position and presence of a subject on a substrate such as a mattress are disclosed here. Unlike monitors that are placed in substantially direct contact with a subject, such as monitors that include electrodes, pressure cuffs, and the like, non-intrusive monitoring, such as the method and apparatus described here, can monitor a condition of a subject without being in substantially direct contact with the subject.

A non-intrusive monitoring apparatus, or one or more portions thereof, can be transported for use by a subject to different locations. Non-intrusive monitoring can include detecting, storing, processing, and communicating information indicating a condition of a subject. For example, a non-intrusive monitoring apparatus can detect condition information, such as presence, position, and pattern of movement of the subject over time, and can communicate the condition information to a monitoring controller that can receive, store, process, and present the condition information, related information, or both, via, for example, an audio or video display device.

[0018] The position of a subject can be the location of the subject on a substrate such as a bed. In addition to the location, the position can include the configuration of the subject's head, torso, legs and feet using heart rate and respiration rate, for example, in addition to center of mass and other pressure measurements. The position can also include whether the subject is lying on his or her right or left side based on heart rate and /or respiration. The position can also include whether the subject is lying down, partially reclining or sitting on the substrate.

[0019] Figure 1 is a diagram of a computing and communications system 100 in accordance with implementations of this disclosure. The computing and communications system 100 can include one or more computing and communication devices 102/104/106, one or more access points 112/114, one or more networks 120, or a combination thereof. Although shown here as including three computing and communication devices 102/104/106, two access points 112/114, and one network 120, the computing and communications system 100 can include any number of computing and communication devices, access points, and networks.

[0020] A computing and communication device 102/104/106 can be any device or system configured to perform wired or wireless communication. For example, a computing and communication device 102 can be configured to perform wireless communication via a wireless communication link 122, via a wired communication link 124, or both. In another example, a computing and communication device 104 can be configured to perform wireless communication via a first wireless communication link 125, via a second wireless communication link 126, or both. In another example, a computing and communication device 106 can be configured to perform wired communication via a first wired communication link 124, can be configured to perform wireless communication via a wireless communication link 126, can be configured to

perform wired communication via a second wired communication link 128, or can be configured to communicate via a combination of wired and wireless communication links 124/126/128.

[0021] The computing and communication devices 102/104/106 can communicate with each other directly via a wired or wireless communication link 124/126, indirectly via an access point, indirectly via the network 120 using one or more a wired or wireless communication links, or via a combination of wired and wireless communication links 122/124/125/126/128. Although each computing and communication device 102/104/106 is shown as a single unit, a computing and communication device can include any number of interconnected elements.

[0022] An access point 112/114 can be any type of device configured to communicate with a computing and communication device 102/104/106, a network 120, or both, via wired or wireless communication links 122/124/125/126/128. For example, an access point 112/114 can include a base station, a base transceiver station (BTS), a Node-B, an enhanced Node-B (eNode-B), a Home Node-B (HNode-B), a wireless router, a wired router, a hub, a relay, a switch, or any similar wired or wireless device. An access point 112/114 can communicate with the network 120 via a wired communication link 132, a wireless communication link 134, or a combination of wired and wireless communication links. Although each access point 112/114 is shown as a single unit, an access point can include any number of interconnected elements.

[0023] The network 120 can be any type of network configured to provide services, such as voice, data, or any other communications protocol or combination of communications protocols, over a wired or wireless communication link. For example, the network 120 can be a local area network (LAN), wide area network (WAN), virtual private network (VPN), a mobile or cellular telephone network, the Internet, or any other means of electronic communication. The network can use a communication protocol, such as the transmission control protocol (TCP), the user datagram protocol (UDP), the internet protocol (IP), the real-time transport protocol (RTP) the Hyper Text Transport Protocol (HTTP), or a combination thereof.

[0024] Figure 2 is a diagram of an exemplary computing and communication device 200 in accordance with implementations of this disclosure. For example, each of the computing and communication devices 102/104/106 shown in Figure 2 can be a computing and communication device 200 as shown in Figure 2. A computing and communication device 200 can include a

communication interface 210, a communication unit 220, a processor 230, a memory 240, instructions 250, a power source 260, or any combination thereof. As used herein, the term “computing device” includes any unit, or combination of units, capable of performing any method, or any portion or portions thereof, disclosed herein.

[0025] The computing and communication device 200 can be a stationary computing device or a mobile computing device. For example, the computing and communication device 200 can be a personal computer (PC), a server, a workstation, a minicomputer, a mainframe computer, a mobile telephone, a personal digital assistant (PDA), a laptop, a tablet PC, or an integrated circuit. Although shown as a single unit, any one or more elements of the communication device 200 can be integrated into any number of separate physical units.

[0026] The communication interface 210 can be a wireless antenna, as shown, a wired communication port, such as an Ethernet port, an infrared port, a serial port, or any other wired or wireless unit capable of interfacing with a wired or wireless communication medium 270. The communication unit 220 can be configured to transmit or receive signals via a wired or wireless communication medium 270, such as radio frequency (RF), ultra violet (UV), visible light, fiber optic, wire line, or a combination thereof. Although Figure 2 shows a single communication unit 220 and a single communication interface 210, any number of communication units and any number of communication interfaces can be used.

[0027] The processor 230 can include any device or system capable of manipulating or processing a signal or other information, such as optical processors, quantum processors, molecular processors, or a combination thereof. For example, the processor 230 can include a general purpose processor, a special purpose processor, a conventional processor, a digital signal processor (DSP), a plurality of microprocessors, one or more microprocessor in association with a DSP core, a controller, a micro controller, an Application Specific Integrated Circuit (ASIC), a Field Programmable Gate Array (FPGA), a programmable logic array, programmable logic controller, microcode, firmware, any type of integrated circuit (IC), a state machine, or any combination thereof. As used herein, the term “processor” includes a single processor or multiple processors. The processor can be operatively coupled with the communication unit 220, the memory 240, the instructions 250, the power source 260, or any combination thereof.

[0028] The memory 240 can include any non-transitory computer-usable or computer-readable medium, such as any tangible device that can, for example, contain, store, communicate, or transport the instructions 250, or any information associated therewith, for use by or in connection with the processor 230. The non-transitory computer-usable or computer-readable medium can be, for example, a solid state drive, a memory card, removable media, a read only memory (ROM), a random access memory (RAM), any type of disk including a hard disk, a floppy disk, an optical disk, a magnetic or optical card, an application specific integrated circuits (ASICs), or any type of non-transitory media suitable for storing electronic information, or any combination thereof. The memory 240 can be connected to, for example, the processor 230 through, for example, a memory bus (not explicitly shown).

[0029] The instructions 250 can include directions for performing any method, or any portion or portions thereof, disclosed here. The instructions 250 can be implemented in hardware, software, or any combination thereof. For example, the instructions 250 can be implemented as information stored in the memory 240, such as a computer program, that can be executed by the processor 230 to perform any of the respective methods, algorithms, aspects, or combinations thereof, as described here. The instructions 250, or a portion thereof, can be implemented as a special purpose processor, or circuitry, that can include specialized hardware for carrying out any of the methods, algorithms, aspects, or combinations thereof, as described herein. Portions of the instructions 250 can be distributed across multiple processors on the same machine or different machines or across a network such as a local area network, a wide area network, the Internet, or a combination thereof.

[0030] The power source 260 can be any suitable device for powering the computing and communication device 200. For example, the power source 260 can include a wired power source; one or more dry cell batteries, such as nickel-cadmium (NiCd), nickel-zinc (NiZn), nickel metal hydride (NiMH), lithium-ion (Li-ion); solar cells; fuel cells; or any other device capable of powering the communication device 200. The communication interface 210, the communication unit 220, the processor 230, the instructions 250, the memory 240, or any combination thereof, can be operatively coupled with the power source 260.

[0031] Although not shown in Figure 2, in some embodiments, the computing and communication device 200 can include a user interface (UI), which can be any unit capable of interfacing with a user, such as a virtual or physical keypad, a touchpad, a display, a touch display, a speaker, a microphone, a video camera, a sensor, or any combination thereof. The UI can be operatively coupled with the processor, as shown, or with any other element of the computing and communication device 200, such as the power source 260. Although shown as a single unit, the UI can include one or more physical units. For example, the UI can include an audio interface for performing audio communication with a user, and a touch display for performing visual and touch based communication with the user.

[0032] Figure 2 shows one exemplary configuration of a computing and communication device 200 and is not meant to imply limitations with respect to the embodiments. Other elements can be used in addition to or in the place of the depicted elements, and the computing and communication device 200 can be implemented on a variety of hardware platforms and software environments, such as various operating systems. Although shown as separate elements, the communication interface 210, the communication unit 220, the processor 230, the instructions 250, the power source 260, the memory 240, the UI, or any combination thereof can be integrated in one or more electronic units, circuits, or chips.

[0033] Figure 3 shows an example of a non-intrusive monitoring apparatus 300 for monitoring a condition of a subject 302 in accordance with this disclosure. In some embodiments, the non-intrusive monitoring apparatus 300 can be used in conjunction with a substrate, such as bed 310. As shown in Figure 3, a subject 302 can be positioned on the bed 310 such that the non-intrusive monitoring apparatus 300 can detect an action or condition, such as movement, a position or a vital sign, of the subject 302. For example, the subject 302 can be resting in a reclined position on the bed 310 above at least a portion of the non-intrusive monitoring apparatus 300, as shown. In some embodiments, the non-intrusive monitoring apparatus 300 can be configured to concurrently detect multiple conditions of the subject 302. For example, the non-intrusive monitoring apparatus 300 can concurrently detect a heart rate, a respiration rate, a position of and movement of the subject 302.

[0034] In some embodiments, the bed 310 can include a frame 312 and one or more padding layers 314. The padding layers 314 can include one or more of a foam pad, a box spring, a mattress, an additional bladder, an air bladder, a straw-filled pad, a feather-filled pad, a sawdust-filled pad, a spring-based pad, or any padding layer capable of supporting the subject 302 and at least a portion of the non-intrusive monitoring apparatus 300. The bed 310 can have a top surface area 316, such as a surface area of a top side of a mattress.

[0035] In some embodiments, the non-intrusive monitoring apparatus 300 can include a monitoring unit 320, a pump 330, a monitoring controller 340, or any combination thereof. The monitoring unit 320, the pump 330, and the monitoring controller 340 can be configured as separate units as shown, or as one or more combined units. For example, the monitoring unit 320 can be configured as a first unit and the pump 330 and the monitoring controller 340 can be configured as a second combined unit, separate from the monitoring unit 320. In another example, the monitoring unit 320, the pump 330, and the monitoring controller 340 can be configured as single combined unit.

[0036] In some embodiments, the monitoring unit 320, or a portion thereof, can be removably positioned on a single padding layer or between two padding layers 314 of the bed as shown. In some embodiments, the bed 310 can include one or more padding layers 314 and the non-intrusive monitoring apparatus 300 can include one or more additional padding layers (not shown). In some embodiments, the monitoring unit 320 can be fixedly attached to one or more padding layers. In some embodiments, the monitoring unit 320 can include one or more bladders 322, one or more sensors 324, one or more inlets 326, or any combination thereof.

[0037] In some embodiments, the bladder 322 can be configured to contain a fluid, such as air, water, or any other appropriate fluid. In some embodiments, the bladder 322 will have foam to self-inflate the bladder 322 and eliminate the need for a pump 330. The bladder 322 can be sized to have a surface area substantially as large as the surface area of the bed 310. For example, the bladder 322 can have a surface area substantially as large as a king-size, queen-size, full, twin, or other sized mattress. Although described as having a surface area that is substantially as large as the surface area of the bed 310, the bladder 322 can be of any size capable of detecting a position of the subject 302 on the bed 310. For example, the surface area

of the bladder 322 can be substantially smaller than the surface area 316 of the bed 310. In some embodiments, the bladder 322 can be configured for use in a chair, automobile seat, hospital bed, crib, or other structure capable of supporting a subject.

[0038] The pressure in the bladder 322 can vary depending on the amount of fluid in the bladder 322, whether the subject 302 is lying on the bladder 322 or sitting on the bladder 322, the heart rate of the subject 302 lying on the bladder 322, the respiration rate of the subject 302 lying on the bladder 322, or other movement of the subject 302 lying on the bladder 322. As used herein the term ‘unladen reference pressure’ can indicate an average fluid pressure within the bladder 322 in the absence of a subject 302 over a period of time, and the term ‘laden reference pressure’ can indicate an average fluid pressure within the bladder 322 in the presence of a subject 302 over a period of time. For simplicity, the term ‘reference pressure’ can indicate the laden or unladen reference pressure.

[0039] In some embodiments, one or more sensors 324 can be configured to detect and measure changes in pressure, incident pressure waves, or both, within the bladder 322. For example, incident pressure waves caused by shifting body weight in response to cardiopulmonary activity can induce a change in pressure that can be detected and measured by the sensors 324. In some embodiments, a sensor 324 can be positioned such that the sensor 324 has a sensing side within the bladder 322 and a reference side outside of the bladder 322. The sensor 324 can include a pressure sensor, such as a semiconductor pressure sensor. In some embodiments, the sensor 324 can include other types of sensors, such as a temperature sensor. The sensor 324 can output a pressure signal indicating measured changes of the pressure in the bladder 322.

[0040] For example, the one or more sensors 324 can include a computing and communication device, such as the computing and communication devices 102/104/106 shown in Figure 1 or the computing and communication device 200 shown in Figure 2, and can be configured to output pressure signals to the pump 330, the monitoring controller 340, to an external device (not shown), or to any combination thereof, via a wired or wireless communication link. In some embodiments, the sensors 324 can be configured to receive and respond to control signals from the monitoring controller 340, an external device, or both. In

some embodiments, the sensors 324 can be configured to condition the pressure signals, which can include amplifying and filtering the pressure signal. For example, the sensors 324 can be configured to generate a pressure signal by measuring the fluid pressure, to condition the pressure signal, and to send the conditioned pressure signal to the pump 330, the monitoring controller 340, an external device, or any combination thereof.

[0041] In some embodiments, the inlet 326 can be configured to provide fluid communication between the bladder 322 and the pump 330. For example, the inlet 326 can be integrated with the bladder 322 and can fluidly communicate with pump 330 via a hose 328 as shown. In another example, the pump 330 can be integrated with the bladder 322 and the hose 328 can be omitted.

[0042] In some embodiments, the non-intrusive monitoring apparatus 300 can include the pump 330, which can be a rotary pump or any other type of pump, configured to maintain a reference or average pressure within the bladder 322. The pump 330 can include an electric line 332 for connection to a power source, the pump 330 can include a self-contained power source, such as one or more batteries, or the pump 330 can include an electric line and a self-contained power source. In some embodiments, the non-intrusive monitoring apparatus 300 can include a self-inflating bladder and the pump 330 can be omitted.

[0043] In some embodiments, the pump 330 can include a sensor 334. For example, a pump housing 336 can provide a casing containing components of the pump 330 and can contain the sensor 334. For example, the sensor 334 can be positioned in a portion of the pump 330 in fluid communication with the hose 328, via, for example, a pressurized fluid outlet 338 of the pump 330. The pressure of the hose 328, which can be in fluid communication with the bladder 322, can correspond to the pressure in the bladder 322. The pump 330, the sensor 334, or both, can be configured for wired or wireless communication. For example, the pump 330 can include a computing and communication device, such as the computing and communication devices 102/104/106 shown in Figure 1 or the computing and communication device 200 shown in Figure 2, and can be configured to communicate with the sensors 324, the monitoring controller 340, an external device (not shown), or with a combination thereof, via a wired or wireless communication link. For example, the pump 330 can be configured to receive the pressure signal

from the sensors 324, to condition the pressure signal, and to send the pressure signal to the monitoring controller 340, to an external device (not shown), or to any combination thereof, via a wired or wireless communication link. In some embodiments, the pump 330, the sensor 334, or both, can be configured to receive and respond to control signals from the monitoring controller 340, an external device, or both.

[0044] In some embodiments, the non-intrusive monitoring apparatus 300 can include a monitoring controller 340. The monitoring controller 340 can be a computing and communication device, such as the computing and communication devices 102/104/106 shown in Figure 1 or the computing and communication device 200 shown in Figure 2, can be configured to communicate with the sensors 324, the pump 330, an external device (not shown), or with a combination thereof, via a wired or wireless communication link, and can be configured to control the non-intrusive monitoring apparatus 300. For example, the monitoring controller 340 can receive a signal indicating the pressure of the bladder 322 and can control the pump 330 to maintain or increase the reference pressure in the bladder 322.

[0045] In some embodiments, the bladder 322, the pump 330, or both, can include a pressure release unit, such as a pressure release valve, configured for releasing pressure in the bladder 322, and the monitoring controller 340 can be configured to control the pressure release unit to decrease the fluid pressure in the bladder 322. In some embodiments, the pressure release unit can include a computing and communication device, such as the computing and communication devices 102/104/106 shown in Figure 1 or the computing and communication device 200 shown in Figure 2, and can be configured to communicate with the sensors 324, the pump 330, the monitoring controller 340, an external device (not shown), or with a combination thereof, via a wired or wireless communication link.

[0046] In an example, the monitoring controller 340 can analyze the pressure signal and can convert it to one or more parameters associated with the subject 302. The parameters can include, but are not limited to, a heart rate, a respiration rate, a change in position, a change in static pressure, or changes in differential pressure between multiple bladders. The parameters can be analyzed to determine a condition of the subject 302, such as a length of sleep, a quality of sleep, a position, a presence or absence in the bed, a blood pressure, tossing and turning

movements, rolling movements, limb movements, weight, a predictive exit from the bladder, or other conditions. For example, the subject 302 can rest against the bladder 322 either directly, or indirectly, via one or more padding layers 314, and each of the subject's heart beats, breaths, and other movements can create a force on the bladder 322 that can be transmitted to one or more sensors 324 each as a wave propagated through the fluid of a different strength and frequency. The one or more sensors 324 can detect the wave, and can generate a corresponding pressure signal α that can be computed into data such as a heart rate, respiratory rate, position change, or other parameter regarding the subject 302.

[0047] In some embodiments, detected pressure signals, parameters, condition information, or a combination thereof, can be stored and analyzed in combination to refine the information or to generate additional information regarding the subject 302. For example, information can be used to generate a unique biological pattern for the subject 302, which can include a combination of heart beat, respiration, weight, static pressure, patterns of position change, or a combination thereof. In one example, the apparatus 300 can determine that an isolated change in pressure, such as a change in pressure caused by placing a heavy static object, such as a suitcase, on the bed 310, was not caused by the subject 302. In another example, information indicating a change in pressure caused by the arrival of the subject 302, such as the subject 302 sitting on the bed, can be combined with the unique heart beat and respiration of the subject 302 to determine if that particular subject 302 is resting on the monitoring unit 320. In some embodiments, the non-intrusive monitoring apparatus 300 can determine changes in position of the subject 302 based on the information. For example, the non-intrusive monitoring apparatus 300 can determine that a subject 302 is lying down flat based on strong heart beat and respiration signals, and the non-intrusive monitoring apparatus 300 can determine that the subject 302 is lying on his or her left side or right side. For example, if the heart beat signal is weak and the respiration signal is strong, the subject 302 is lying on the right side.

[0048] The monitoring controller 340 can receive the conditioned pressure signal from the sensors 324 and can perform pattern recognition, or other calculations, based on the conditioned pressure signal to determine the position, heart rate, respiratory rate, or other bio-signal properties or conditions associated with the subject 302. For example, the heart rate can be

identified based on a portion of the signal that has a frequency in the range of 0.5-4.0 Hz and the respiration rate can be identified based on a portion of the signal has a frequency in the range of less than 1 Hz. The monitoring controller 340 can also receive signals from other sensors, such as a temperature sensor. The monitoring controller 340 can receive and process signals from a plurality of sensors 324 in a non-intrusive monitoring apparatus 300, or from different non-intrusive monitoring apparatuses in use by different subjects.

[0049] The monitoring controller 340 can send information, such as information indicating the parameters of the subject, such as the position, heart rate, and respiratory rate, to an external device, which can be accessible to a user, such as a text messaging platform, a data logger, a printer, an alarm system, an alert siren, or other data acquisition or actuating device, or a computer capable of performing analytical functions.

[0050] Medical facilities such as hospitals, nursing homes and psychiatric institutions can use the non-intrusive monitoring apparatus 300 for many different reasons. A medical facility might use the non-intrusive monitoring apparatus 300 in each bed, or each bed of a ward or floor, with each subject 302 or patient associated with a non-intrusive monitoring apparatus 300 or bed, providing instant information to the user of which beds include patients, which beds are available to new patients, what position each patient currently has in each bed, which patients are moving in their beds, etc. Because the non-intrusive monitoring apparatus 300 is a non-contact monitoring system, patients need not be “hooked up” to the apparatus. The system does not need to be turned on by an employee or otherwise initiated. The system can begin to monitor the patient as soon as the patient rests against the bladder 322.

[0051] There are additional uses for the non-intrusive monitoring apparatus 300 in medical facilities. Non-limiting examples include providing a current and historical account of patient vital signs such as respiration and heart rate to caregivers and providing a current and historical account of patient motion to prevent bed sores, presence in bed, or absence from bed. In addition, the non-intrusive monitoring apparatus 300 can be configured to predict when a patient will exit a bed based on the pressure pattern of the patient’s position sensed with reference to the edges of the bed, for example, and indications of directional motion of the patient sensed before a patient’s absence. An example monitoring unit 320 configured for use in

pinpointing patient position and detecting direction of patient motion is described with reference to Figure 4 below.

[0052] Figures 4A and 4B show a top view of a pair of bladders 400/402 for monitoring a position of a subject 302 using the non-intrusive monitoring apparatus 300 of Figure 3. The pair of bladders 400/402 can be stacked one on top of the other and positioned on top of, below, or between padding layers, for example, between padding layers 314 in a similar position to bladder 322 in Figure 3. The bladder 400 of Figure 4A includes a horizontal seam 404 separating the bladder 400 into two portions A/B. The seam 404 can be created by any means known to those skilled in the art. The horizontal seam 404 creates a horizontal zig-zag pattern on the bladder 400, splitting the bladder 400 into the two portions A/B. In the example shown here, portion A includes fingers, or teeth, that extend between the fingers, or teeth, of portion B. Though the fingers or teeth shown in Figure 4A are triangular, they can also be in any other shape. The design is configured such that the portions A/B are interleaved, allowing each portion A/B to sense position in a linear manner. Though each of the portions A/B shown in Figure 4A includes approximately half of the bladder 400, the horizontal seam 404 can also be configured to divide the bladder 400 into quarters, eights, sixteenths, or unequally sectioned portions.

[0053] By separating the bladder 400 into interleaved portions A/B, the pressure can be measured independently in each portion A/B. The seam 404 is configured so that each interleaved portion A/B extends nearly the entire width of the bladder 400. This allows for each interleaved portion A/B to have some degree of pressure exerted on it by the subject at nearly any location on the bladder 400, as opposed to a vertical seam creating portions that are not interleaved. This degree of pressure can be interpreted based on the amount or percentage of the portion to which the subject is exposed when compared to the degree of pressure on the other interleaved portion.

[0054] In one example, the bladder 400 can include or be in communication with one or more pressure sensors 420/422. The one or more pressure sensors 420/422 can be configured to measure the pressure both in portion A and portion B. The sensors 420/422 can be positioned at any location along the portion the sensors 420/422 will be measuring. The pressure in portion A will increase linearly as a subject, e.g. subject 302 shown in Figure 3, moves toward the left side

of the bladder 400. In a similar manner, the pressure in portion B will increase linearly as the subject 302 moves toward the right side of the bladder 400.

[0055] The difference in pressure between portion A and portion B can be used to represent the horizontal position of, for example, the subject 302 reclining or sitting on a substrate such as a bed or mattress including the bladder 400. Figures 4A and 4B also show graphical representations of pressure differentials along the seamed bladders 400/402 by subject 302 position. In graph 406, the horizontal position of a subject 302 is shown along the x-axis. This horizontal position is represented using horizontal indicators, 1-10, shown both below the bladder 400 and on the x-axis label of the graph 406. An example normalized linear representation of the pressure differential, that is, the pressure of portion A minus the pressure of portion B, for a subject 302 moving from the left side to the right side of the bladder 400 is shown along the y-axis.

[0056] For example, if a subject 302 has a center of mass located at the horizontal position denoted by '3' both on the bladder 400 and on the graph 406, the pressure differential between the portions, *e.g.* pressure of portion A minus pressure of portion B, would also be approximately '3.' If a subject 302 has a center of mass located at the horizontal position denoted by '8' both on the bladder 400 and on the graph 406, the pressure differential between the portions would be approximately '-4.' Thus, by calculating the pressure differential between the portions A/B of the bladder 400, the horizontal position of the subject 302 can be predicted.

[0057] The pressure differential between the portions A/B of the bladder 400 can provide predictive capabilities of a subject's action based on movement, such as exit from the bladder. By capturing a string, or stream, of pressure differentials while the subject 302 moves along the bladder 400, the horizontal direction of motion of the subject 302 is determined. From the position pattern, including one or both of speed of movement and trajectory of movement, as examples, an action of the subject can be predicted. For example, if the trajectory is toward an edge of the bed in which the bladder 400 is incorporated, an action such as exit of the bed can be predicted. This prediction can trigger an indication or alarm to a caregiver that the subject is about to exit the bed, calling the caregiver to the subject to assist in the exit and getting to the desired location without falling. The predication can trigger a reminder or alarm for the subject.

For example, a verbal warning may be triggered for the subject to call a nurse for assistance before getting out of bed.

[0058] If the stream of pressure differentials is followed by a subsequent absence of the subject 302 from the substrate, the representative pressure differentials can be stored, for example, in the memory 240 of the computing and communication device 200 shown in Figure 2, and associated as a position pattern of pressure differentials indicative of the subject 302 being about to exit the bed or mattress. The historical position pattern data can be used to assist in predicting the action of the subject. For example, if the subject always gets out of bed on the same side, but the current trajectory of the position pattern is toward the opposite side, an action such as exiting the bed may not be predicted. If the subject always pauses in a sitting position before exiting, the center of mass near the edge of the bed can trigger a prediction of bed exit. If the same, or similar, string or pattern of pressure differentials is captured, an alert or an alarm can be sent to a caregiver to indicate that the subject 302 might be about to exit the bed or mattress. This can prevent falls, which is a serious problem in medical facilities.

[0059] The bladder 402 shown in Figure 4B includes a vertical seam 408 separating the bladder 402 into two portions C/D. The vertical seam 408 creates a vertical zig-zag pattern on the bladder 402, splitting the bladder 402 into the two portions C/D. In the example shown here, portion C includes fingers, or teeth, that extend between the fingers, or teeth, of portion D. The seam 408 is configured so that each interleaved portion C/D extends nearly the entire length of the bladder 402. This allows for each interleaved portion C/D to have some pressure exerted on it by the subject at nearly any location on the bladder 402, as opposed to a horizontal seam creating portions that are not interleaved. Though the fingers or teeth shown in Figure 4B are triangular, they can also be in any other shape. Further, though each of the portions C/D shown in Figure 4B includes approximately half of the bladder 402, the vertical seam 408 can also be configured to divide the bladder 402 into quarters, eights, sixteenths, or unequally sectioned portions.

[0060] In a similar manner as described with respect to bladder 400, the pressure can be measured independently in each portion C/D of the bladder 402 with pressure sensors 424/426. The sensors 424/426 can be positioned at any location along the portions that the sensors

424/426 will be measuring. The pressure in portion C will increase linearly as a subject, e.g. subject 302 shown in Figure 3, moves toward the top of the bladder 402. In a similar manner, the pressure in portion D will increase linearly as the subject 302 moves toward the bottom of the bladder 402.

[0061] The difference in pressure between portion C and portion D can be used to represent the vertical position of, for example, the subject 302 reclining or sitting on a substrate such as a bed or mattress including the bladder 402. In graph 410, the vertical position of a subject 302 is shown along the x-axis. This vertical position is represented using vertical indicators, 1-10, shown both on the side of the bladder 402 and on the x-axis label of the graph 410. An example normalized linear representation of the pressure differential, that is, the pressure of portion C minus the pressure of portion D, for a subject 302 moving from the bottom to the top of the bladder 402 is shown along the y-axis.

[0062] For example, if a subject 302 has a center of mass located at the vertical position denoted by '3' both on the bladder 402 and on the graph 410, the pressure differential between the portions, e.g. portion C minus portion D, would be approximately '-4.' If a subject 302 has a center of mass located at the vertical position denoted by '8' both on the bladder 402 and on the graph 410, the pressure differential between the portions would be approximately '4.' Thus, by calculating the pressure differential between the portions C/D of the bladder 402, the vertical position of the subject 302 can be predicted. In the same manner as was described with respect to horizontal motion and prediction in reference to bladder 400 and graph 406, pressure differentials between portions C/D can be used to determine the path of vertical motion and predict when a subject 302 is about to exit the substrate, e.g. the bed or mattress.

[0063] The bladders 400/402 shown in Figures 4A and 4B can be stacked together, one on top of the other, to provide a center of mass for the subject 302 based on both horizontal and vertical position as determined by the pressure differentials between portions A/B of bladder 400 and portions C/D of bladder 402. Also, both horizontal motion and vertical motion of a subject 302 can be captured and stored before and after an exit event for use in further prediction if both bladders 400/402 are used at the same time with the non-intrusive monitoring apparatus 300.

Example subject 302 positions based on stacking of the bladders 400/402 are described in respect to Figures 5A-5C.

[0064] Figures 5A-5C are representative of the two bladders 400/402 layered to receive the subject 302. In Figure 5A, the subject 302 is shown in the center of the bladders 400/402, which would equate to a pressure differential of zero for both bladders 400 and 402. In Figure 5B, the subject 302 is horizontally centered but not vertically centered. Therefore, the pressure differential of bladder 400 would be zero while the pressure differential of bladder 402 would be C-D, a positive number greater than zero. In Figure 5C, the subject 302 is neither horizontally centered nor vertically centered. Therefore, the pressure differential of bladder 400 would be A-B, a negative number with an absolute value greater than zero, while the pressure differential of bladder 402 would be C-D, a positive number greater than zero.

[0065] Combining and subtracting information from both sets of bladders can also give additional information about the subject's position. In addition to static position, the first derivative of the position information can be used to predict which direction the subject 302 is moving. In addition to the first derivative, the second derivative can be calculated to give the rate at which the subject 302 is moving toward the edge of the bed. This information can be used to predict a bed exit before it actually happens. These predictions using static position or first derivative or second derivative can be used to indicate, such as by an audible alert or a text or email message over the local network or internet, to a care giver that a subject 302 is about to exit a bed. The alert can reduce the number of falls while getting out of bed or help keep track of the subject's 302 movement patterns.

[0066] Figure 6 illustrates another embodiment of a seamed bladder 450 for monitoring a position of a subject 302 using the apparatus of Figure 3. As described above in respect to Figures 4A and 4B, the bladder can be divided into more than two portions. As shown in the example embodiment of Figure 6, the bladder 450 is divided into four portions 452/454/456/458. Each of the four portions 452/454/456/458 has at least two pressure sensors (shown but not numbered). The four portions 452/454/456/458 of Figure 6 are provided by means of example and are not meant to be limiting. Other numbers of bladder portions, either equal or unequal in portioning, are also contemplated.

[0067] Figure 7 is representative system architecture for monitoring the position of a subject 302 in accordance with implementations of this disclosure. A group of pressure sensors 460 is shown as including pressure sensors that measure the pressure differential in at least two bladders (right pressure sensor and left pressure sensor for one bladder, top pressure sensor and bottom pressure sensor for another bladder). In addition, pillow pressure sensors and other pressures sensors are also shown in the group of pressure sensors 460 to indicate that additional pressure measurements can be made in association with the system for monitoring the position of the subject 302.

[0068] Each sensor in the group of pressure sensors 460 can communicate with a signal conditioner 462. The signal conditioner 462 can analyze the data and/or signals captured by each sensor in the group of pressure sensors 460 by, for example, amplifying, filtering noise, and configuring the data and/or signals for use by a micro controller 464. The micro controller 464 can receive the conditioned pressure signals from the group of pressure sensors 460 and can perform pattern recognition, or other calculations, based on the conditioned pressure signals to determine the position, heart rate, respiratory rate, or other bio-signal properties or conditions associated with the subject 302. The micro controller 464 can send information, such as information indicating the parameters of the subject, such as the position, heart rate, and respiratory rate, to an external device using a communication link 466. The communication link can be any type of wired or wireless communication link such as the communications links 122/124/125/126/128 described in respect to Figure 1. A method of using the non-intrusive monitoring apparatus 300 equipped with one or more bladders, such as bladders 400/402, is described in respect to Figure 8 below.

[0069] Figure 8 shows an example of a method 500 of non-intrusive monitoring using a non-intrusive monitoring apparatus, such as the non-intrusive monitoring apparatus 300 shown in Figure 3, in accordance with embodiments of this disclosure. For example, non-intrusive monitoring can include monitoring a subject 302 to predict when the subject 302 will exit a bed or mattress or identify when the subject 302 has already vacated the bed or mattress. Non-intrusive monitoring can include sensing an incident pressure change at 510, generating a pressure signal at 520, processing the pressure signal at 530, determining whether the subject 302

is in bed at 540, generating a pattern associated with the subject 302 at 550, presenting information to a user at 560, or any combination thereof.

[0070] In some embodiments, an incident pressure change can be sensed at 510. For example, one or more sensors, such as the sensors 420/422/424/426 shown in Figures 4 and 5, can receive and measure incident pressure waves within one or more bladders, such as one or both of the divided bladders 400/402 shown in Figures 4 and 5. In some embodiments, the one or more sensors 420/422/424/426 can generate signals representing the pressure waves at 520. A different signal can be generated for each of the portions A/B or C/D of the divided bladders 400/402. The sensors 420/422/424/426 can send the generated signals to a control device, such as the monitoring controller 340 shown in Figure 3.

[0071] In some embodiments, the monitoring controller 340 can process the signals at 530. For example, the monitoring controller 340 can store pressure signals or send them to remote storage or can combine pressure signals with other information associated with a subject, such as the subject 302 shown in Figure 3. The pressure signals, the other information, or both, can be associated with an identifier identifying the subject 302 and with an identifier identifying the substrate, *e.g.* mattress or bed, associated with the signals.

[0072] In some embodiments, the monitoring controller 340 can determine the presence of the subject 302, that is, whether the subject 302 is in bed at 540. For example, the determination can be based on the presence or absence of pressure signals or the magnitude of the pressure signals. For example, a small object, such as a suitcase, would create pressure signals of lower magnitude than a subject 302 lying on the bed. In some embodiments, the control device can determine that a different subject is in the bed. For example, the pressure signals can differ in pattern or magnitude than previously stored pressure signals for the subject 302 associated with, or assigned to, the mattress or bed.

[0073] In some embodiments, a pattern associated with the subject 302 can be generated at 550. For example, the pattern can be generated based on the pressure signals and other information associated with the subject 302. The pattern can also be associated with the identifier identifying the subject 302 and with the identifier identifying a bed associated with the subject 302. The pattern can include historical information related to direction of movement of the

subject 302, duration of movement of the subject 302, presence of the subject 302, position of the subject 302 over time, or any other indicators or conditions that can be used both to identify a specific subject 302 and predict when the subject 302 is about to exit a mattress or bed.

[0074] In some embodiments, information associated with the signal can be presented to a user at 560. For example, information indicating whether the subject 302 is in bed can be sent to an external device for presentation to a user, such as hospital or nursing home personnel. In another example, the information can indicate that a different subject is in the bed. In another example, the information can indicate that the subject 302 is about to exit the bed, based on a pattern for the subject 302 including position of the subject 302 on the bed and direction of movement of the subject 302 that can be associated with previous exits from the bed.

[0075] When the subject 302 is a patient, bladders 400/402 can be incorporated into a hospital bed with apparatus 300, and the system can calculate the direction of movement of the patient and can issue an alert when the patient gets to the edge of the bed or has crossed over a predetermined threshold in one or both of the horizontal and vertical positions on the bed. An example threshold 410 is illustrated in Figure 4A. The threshold 410 can be associated with a predetermined pressure differential, indicating the patient is approaching an edge of the bed. In response to the alert, a caregiver can reach the patient before the patient gets out of bed, reducing the potential for falls, a problem medical facilities work to reduce. Historical position data can be stored and combined with real time position data to assist in earlier and more accurate determinations of a bed exit. Supervision can be provided to the patient when the caregiver receives an indication that a patient is starting to repeat a pattern that was previously associated with an exit from a bed. Being able to provide assistance to patients as they get out of bed can reduce the number of slip and fall accidents in a medical facility setting.

[0076] In another example, the subject 302 can be a participant in a rehabilitation or detention program at a public or private facility. Supervisory personnel can be sent to monitor the participant when personnel at the facility receive an indication that the participant is starting to repeat a pattern previously associated with an exit from a substrate, such as a mattress, bed, or chair. Being able to monitor the participant as they attempt to leave a substrate can reduce the number of participants that attempt to get around the rules or regulations of the given program.

[0077] The embodiments herein can also be modified to be used in an automobile seat. When used with an automotive seat, the subject 302 can be the driver of a vehicle and the apparatus can create a sleepiness score based on one or more vital signs. The sleepiness score can, for example, indicate impending sleep when heart rate is low, when respiratory rate is low, and when movements are infrequent. Over time, the database can accumulate sleepiness scores for a variety of conditions (e.g., a lower pressure in one or more bladders, a high pressure in one or more bladders, a cool temperature, and/or a warm temperature). An association can then be made using the sleepiness information between the sleepiness score and environmental conditions, such as the pressure in the one or more bladders and the temperature within the vehicle. The association can be performed by the controller or another processor in communication with the database.

[0078] The association between the sleepiness score and environmental conditions can include, for example, determining a correlation between the sleepiness score and environmental conditions. Based on the association, a pressure setting can be determined for customizing the environmental conditions (e.g., pressure in the one or more bladders and temperature in the vehicle) to achieve a low sleepiness score. The embodiments herein adapted for use in an automobile seat can capture positional data over time and feed the results to the control unit to send commands to the pump to inflate or deflate the bladders to manipulate the position of the driver against the automobile seat.

[0079] The non-intrusive monitoring system can also be used for many applications in a home setting. There is no extensive training, preparation, or change in a subject's behavior in order to incorporate the system into regular use. A medical facility might send such a system home with a patient upon discharge and use an on-site monitoring program to actively monitor that patient's parameters or conditions for a period of time following major surgery, for example. Professional home health care providers can also use the system to enhance their capabilities and improve care. Non-professional care givers can use the monitoring system to gather data for physicians, set reminders for the turning of a patient or providing medication, etc. Periodic updates can be wirelessly sent to a medical professional. Professional home health care workers

and non-professional caregivers can utilize the monitoring system for family members with dementia.

[0080] While the embodiments have been described in connection with what is presently considered to be the most practical examples, it is to be understood that the disclosure is not to be limited to these examples but, on the contrary, is intended to cover various modifications and equivalent arrangements included within the spirit and scope of the appended claims, which scope is to be accorded the broadest interpretation so as to encompass all such modifications and equivalent structures as is permitted under the law.

What is claimed is:

1. A method for monitoring a subject, comprising:
sensing incident pressure waves generated by the subject moving on a divided bladder comprising interleaved portions with at least one sensor in fluid communication with a respective portion of the divided bladder;
generating signals indicative of the incident pressure waves for each of the interleaved portions of the bladder and sending the signals to a processor;
determining a position of the subject on the divided bladder based on a difference between the signals from each of the interleaved portions; and
generating a position pattern for the subject over a period of time.
2. The method of claim 1, further comprising:
sending an indication to an external device if the position of the subject crosses a threshold, the threshold being a certain distance from an edge of a bed in which the divided bladder is incorporated.
3. The method of claim 1, further comprising:
predicting an action of the subject while on the divided bladder based on the position pattern, wherein the action is exiting a bed in which the divided bladder is incorporated.
4. The method of claim 3, further comprising:
communicating information related to the action of the subject to an external device; the information configured to trigger assistance with the action or prevention of the action.
5. The method of claim 3, wherein predicting the action comprises generating an estimated position pattern based on one or both of a speed and a direction of the generated position pattern.

6. The method of claim 1, wherein:
the interleaved portions are divided vertically and the position of the subject is a horizontal position relative to the divided bladder, or
the interleaved portions are divided horizontally and the position of the subject is a vertical position relative to the divided bladder.

7. The method of claim 1, further comprising:
determining a configuration of the subject on the divided bladder based on one or both of a magnitude and a frequency of the signals from each of the interleaved portions, the configuration being one of lying down, partially reclining, and sitting up.

8. The method of claim 7, wherein determining the configuration comprises distinguishing one or both of a heart rate a respiration rate from the signals.

9. The method of claim 1, wherein the divided bladder comprises a first bladder having two horizontal interleaved portions and a second bladder having two vertical interleaved portions, and wherein determining the position of the subject on the divided bladder is based on the difference between the signals from each of the interleaved portions of both the first bladder and the second bladder.

10. A non-intrusive monitoring device for monitoring a subject, the device comprising:
a divided bladder comprising interleaved portions;
one or more sensors in fluid communication with each of the interleaved portions of the divided bladder wherein the one or more sensors are configured to generate signals in response to pressure variations resulting from movement of a subject on the divided bladder;
and

a processor configured to:

receive signals from the one or more sensors for each of the interleaved portions;

determine the subject's position on the divided bladder based on a difference between the signals from each of the interleaved portions; and

generate a position pattern for the subject over a period of time.

11. The device of claim 10, wherein the processor is further configured to:
send an indication to an external device if the position of the subject crosses a threshold, the threshold being a certain distance from an edge of a bed in which the divided bladder is incorporated.

12. The device of claim 10, wherein the processor is further configured to:
predict an action of the subject while on the divided bladder based on the position pattern, wherein the action is exiting a bed in which the divided bladder is incorporated.

13. The device of claim 12, wherein the processor is further configured to:
communicate information related to the action of the subject to an external device; the information configured to trigger assistance with the action or prevention of the action.

14. The device of claim 12, wherein, when predicting the action, the processor is further configured to generate an estimated position pattern based on one or both of a speed and a direction of the generated position pattern.

15. The device of claim 10, wherein:
the interleaved portions are divided vertically and the position of the subject is a horizontal position relative to the divided bladder, or
the interleaved portions are divided horizontally and the position of the subject is a vertical position relative to the divided bladder.

16. The device of claim 10, wherein the processor is further configured to:
determine a configuration of the subject on the divided bladder based on one or both of a magnitude and a frequency of the signals from each of the interleaved portions, the configuration being one of lying down, partially reclining, and sitting up.

17. The device of claim 10, wherein the divided bladder comprises a first bladder having two horizontal interleaved portions and a second bladder having two vertical interleaved portions, and wherein the processor determines the position of the subject on the divided bladder based on the difference between the signals from each of the interleaved portions of both the first bladder and the second bladder.

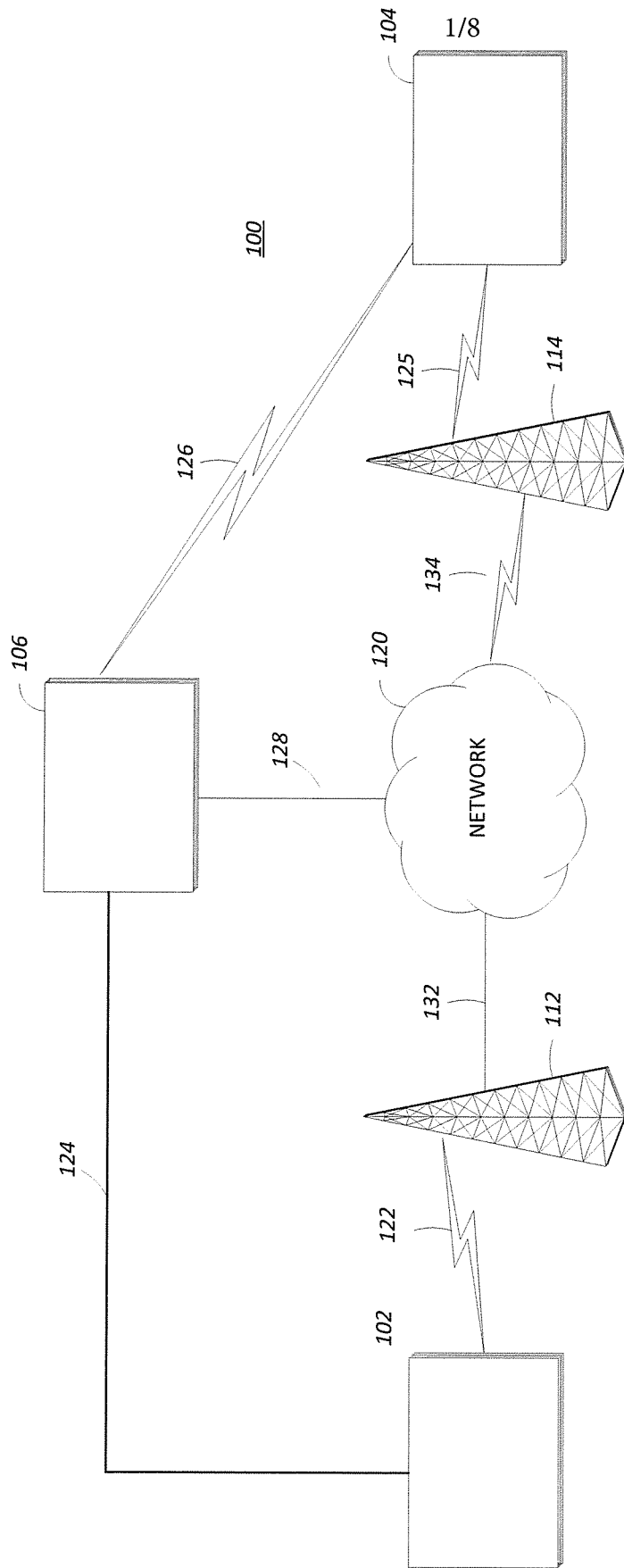

Figure 1

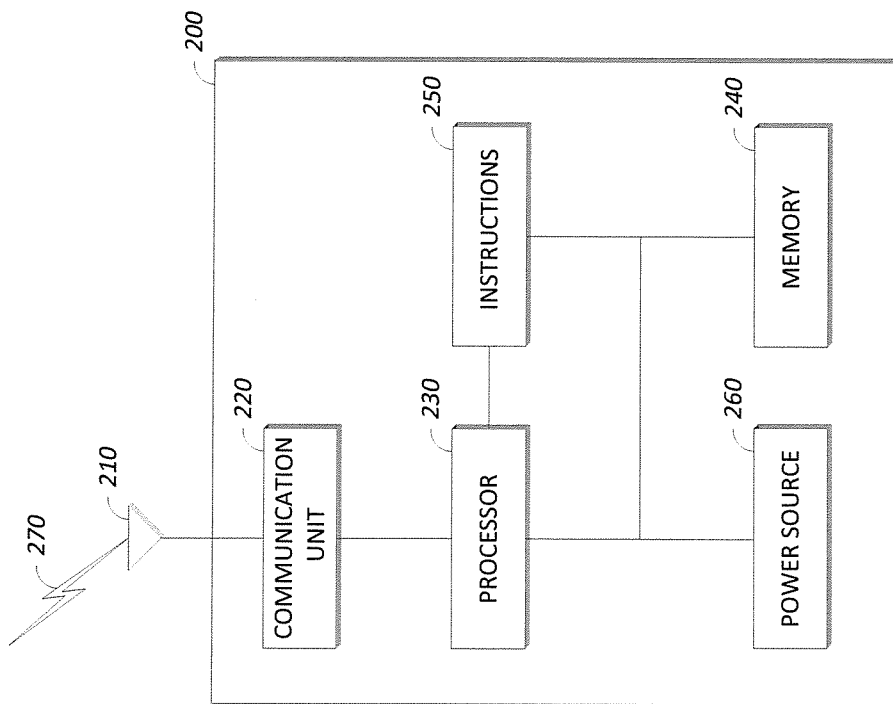

Figure 2

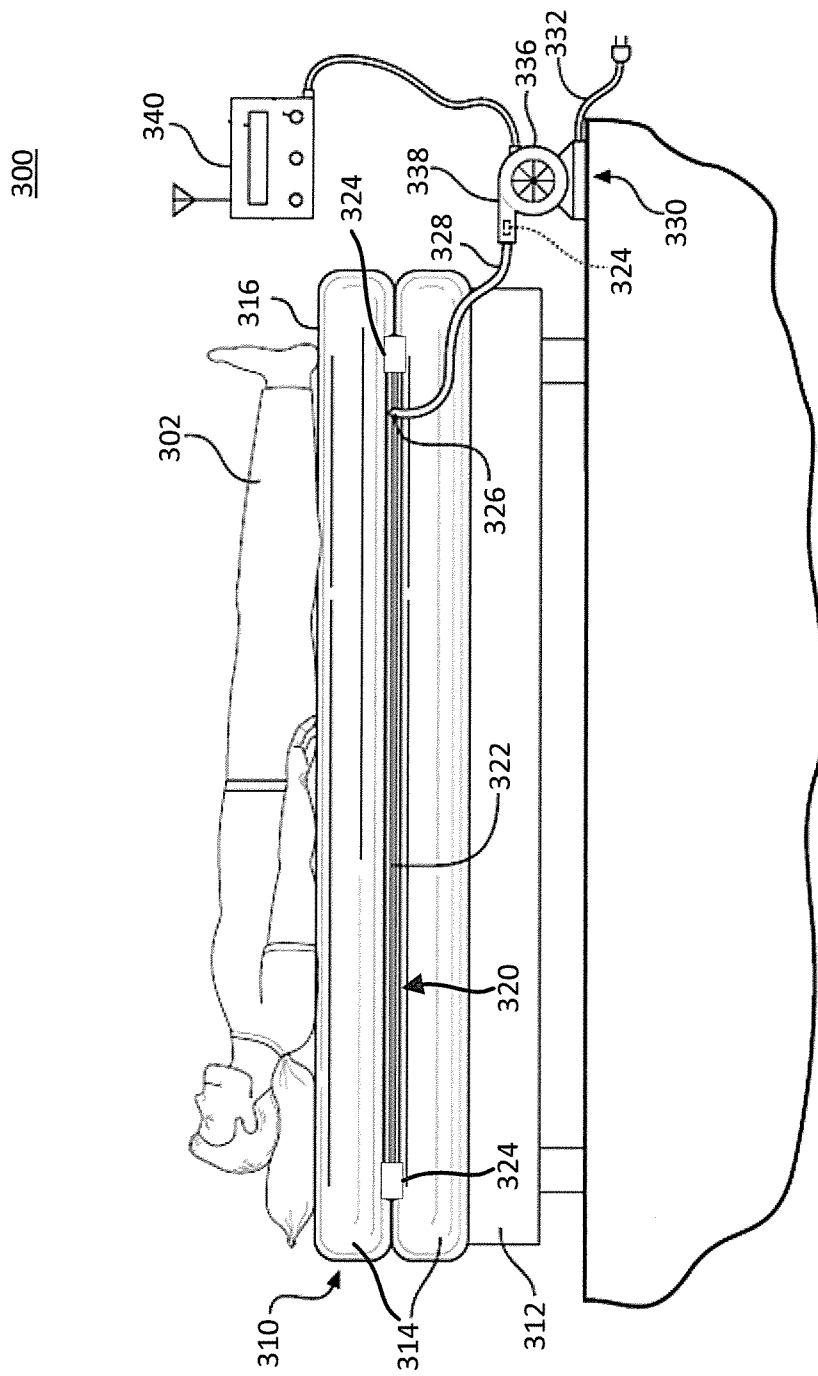

Figure 3

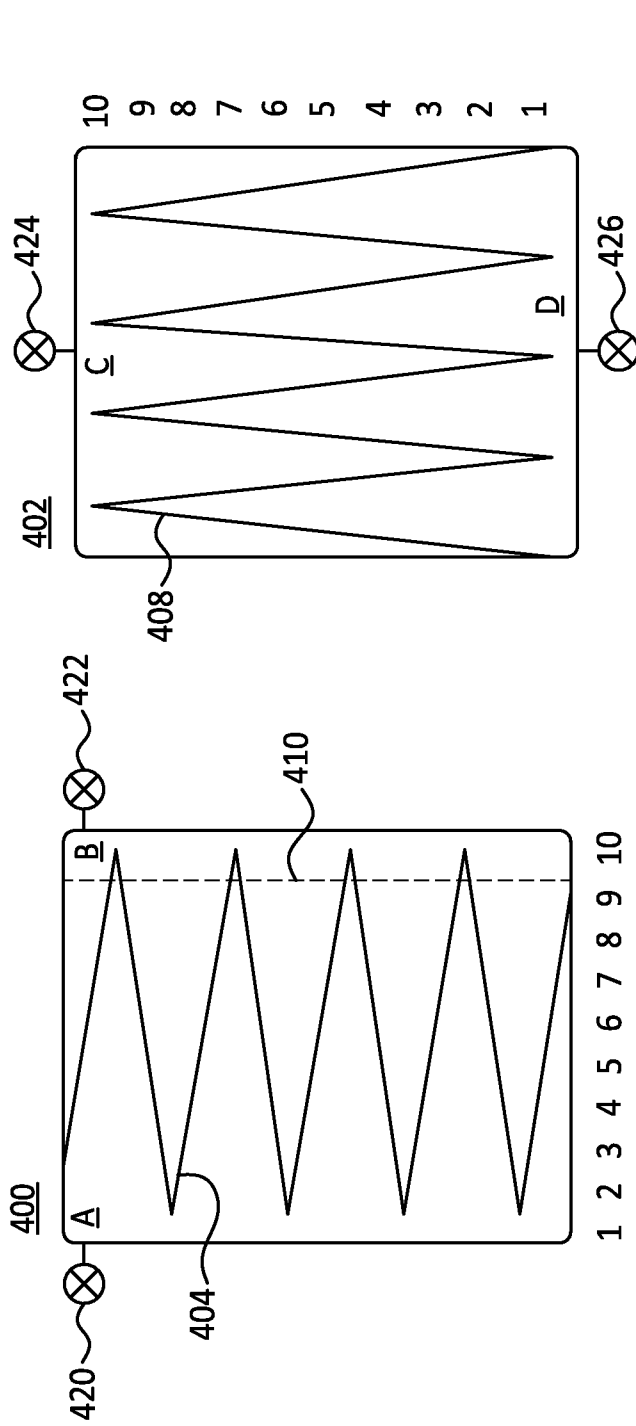

Figure 4A

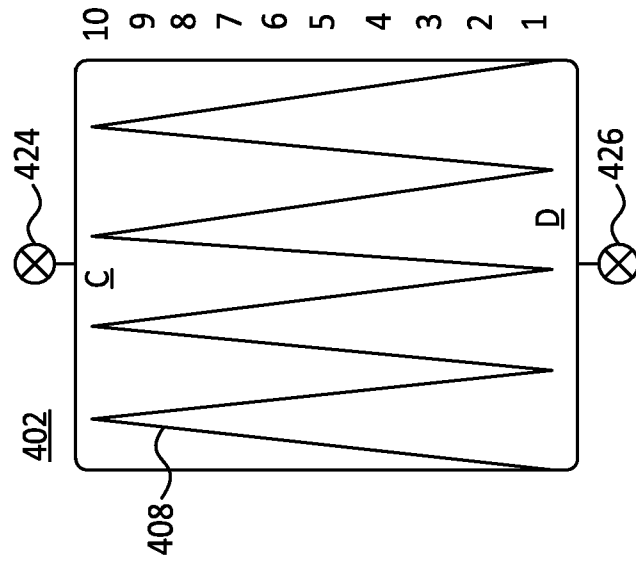

Figure 4B

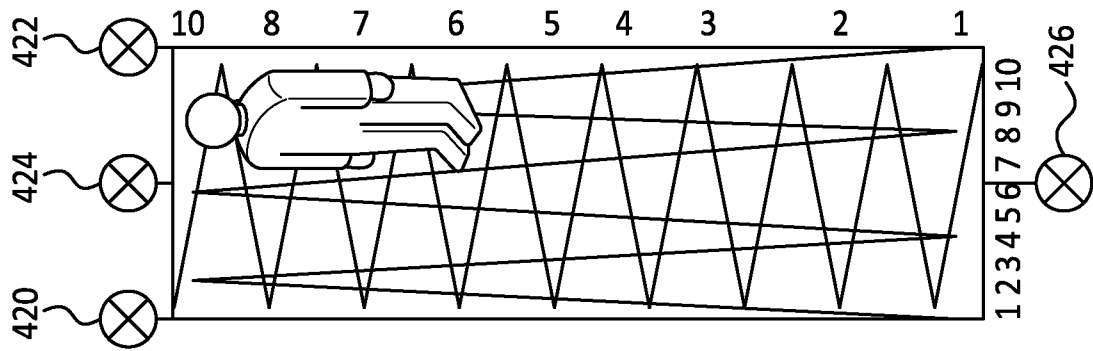

Figure 5C

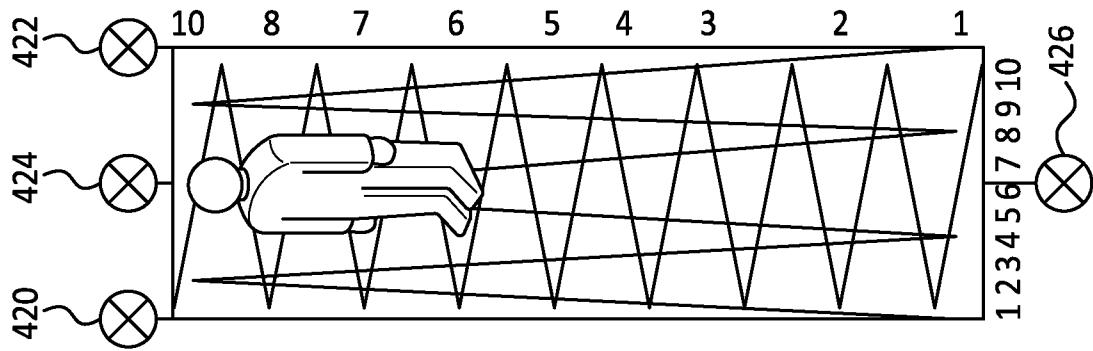

Figure 5B

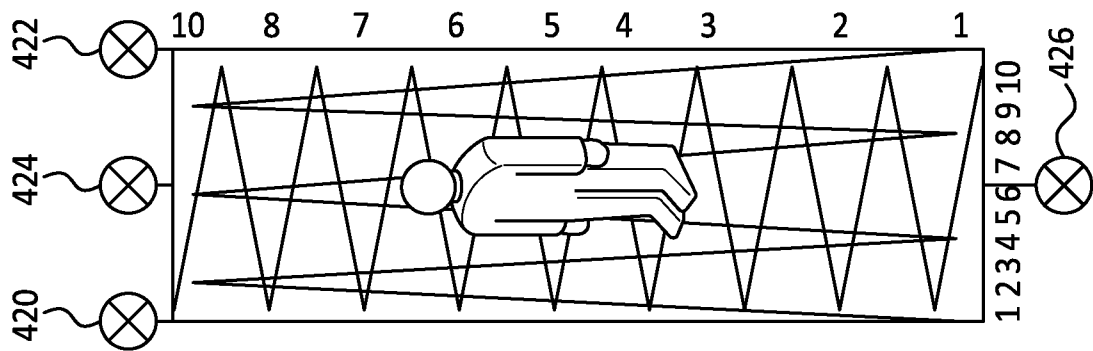

Figure 5A

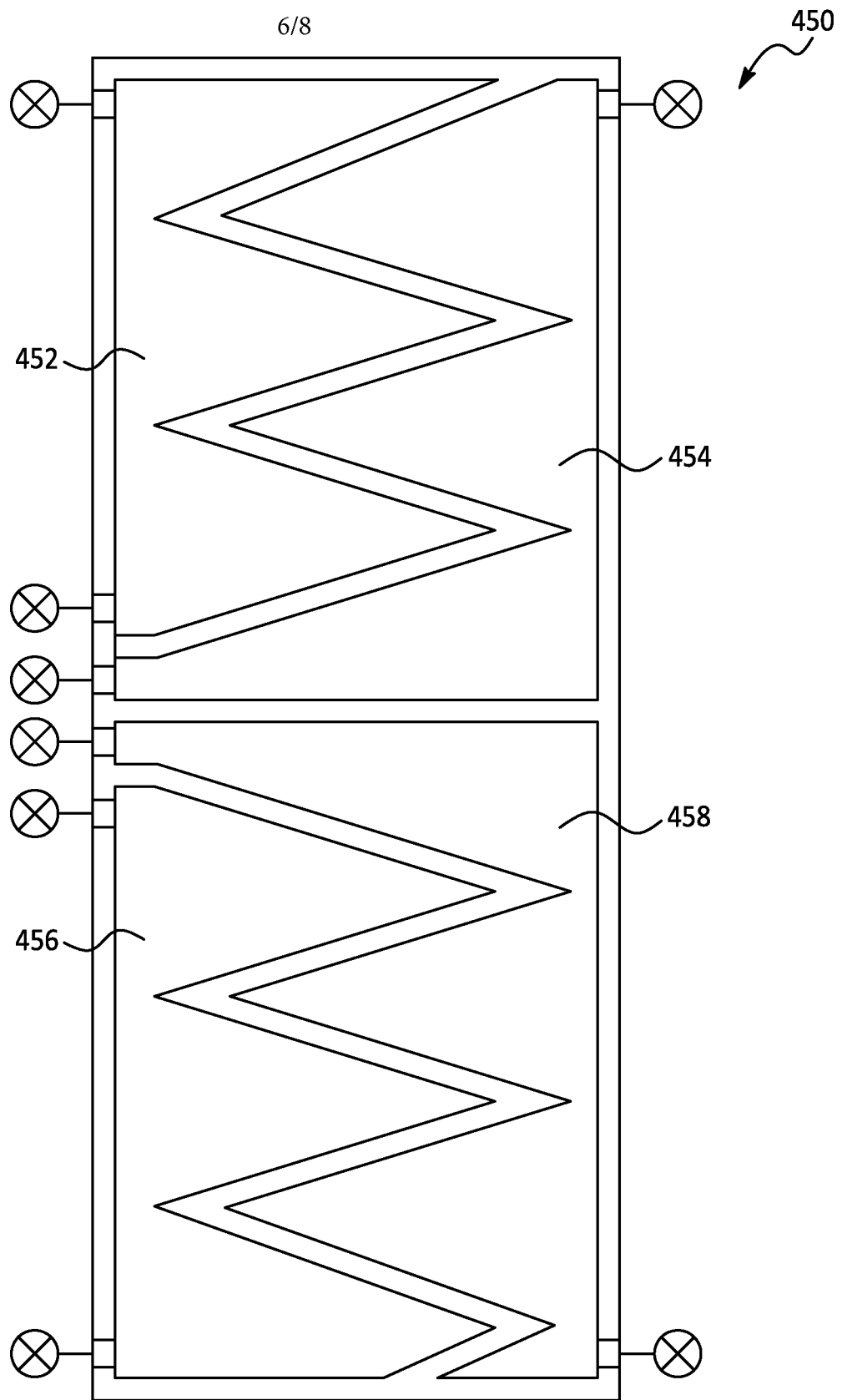

Figure 6

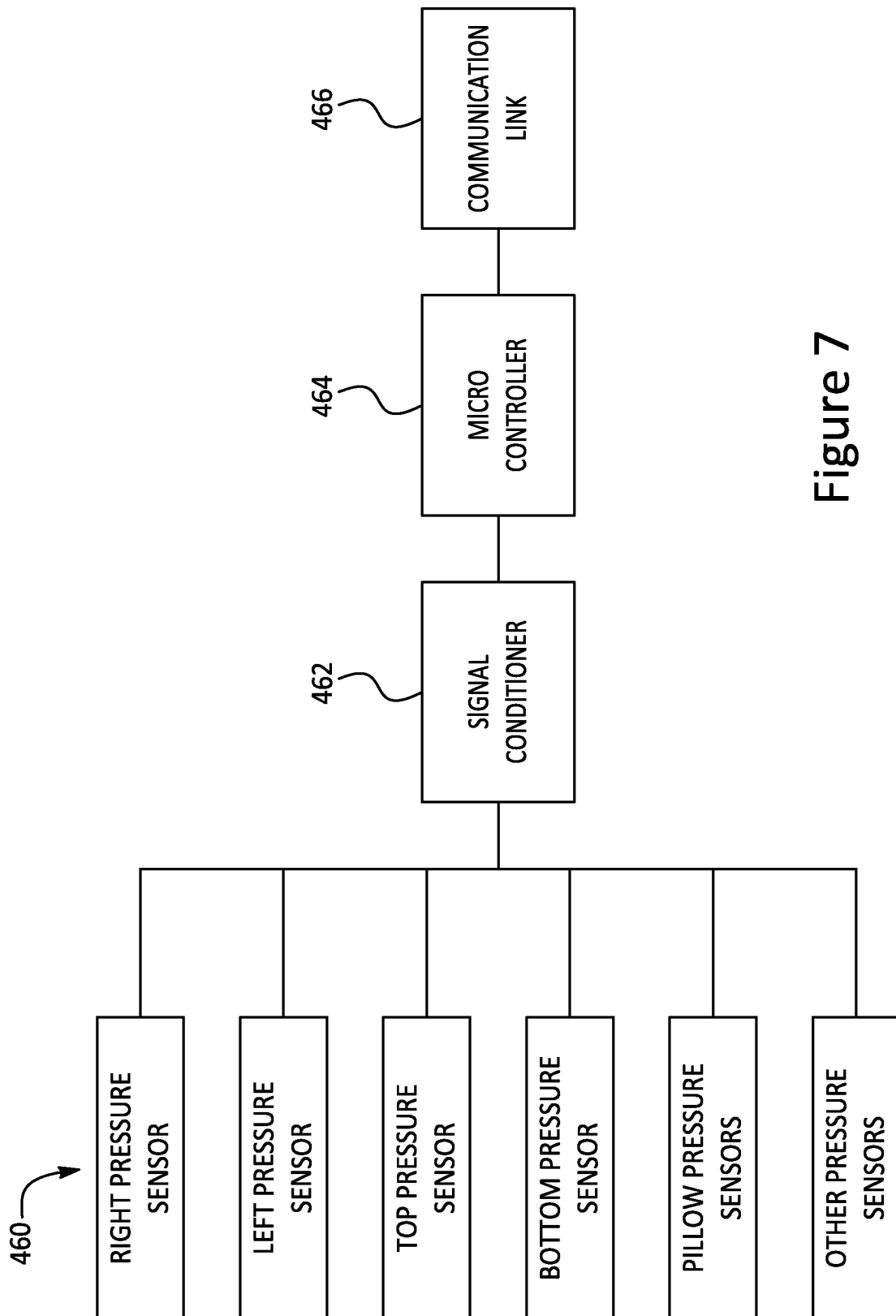

Figure 7

8/8

500

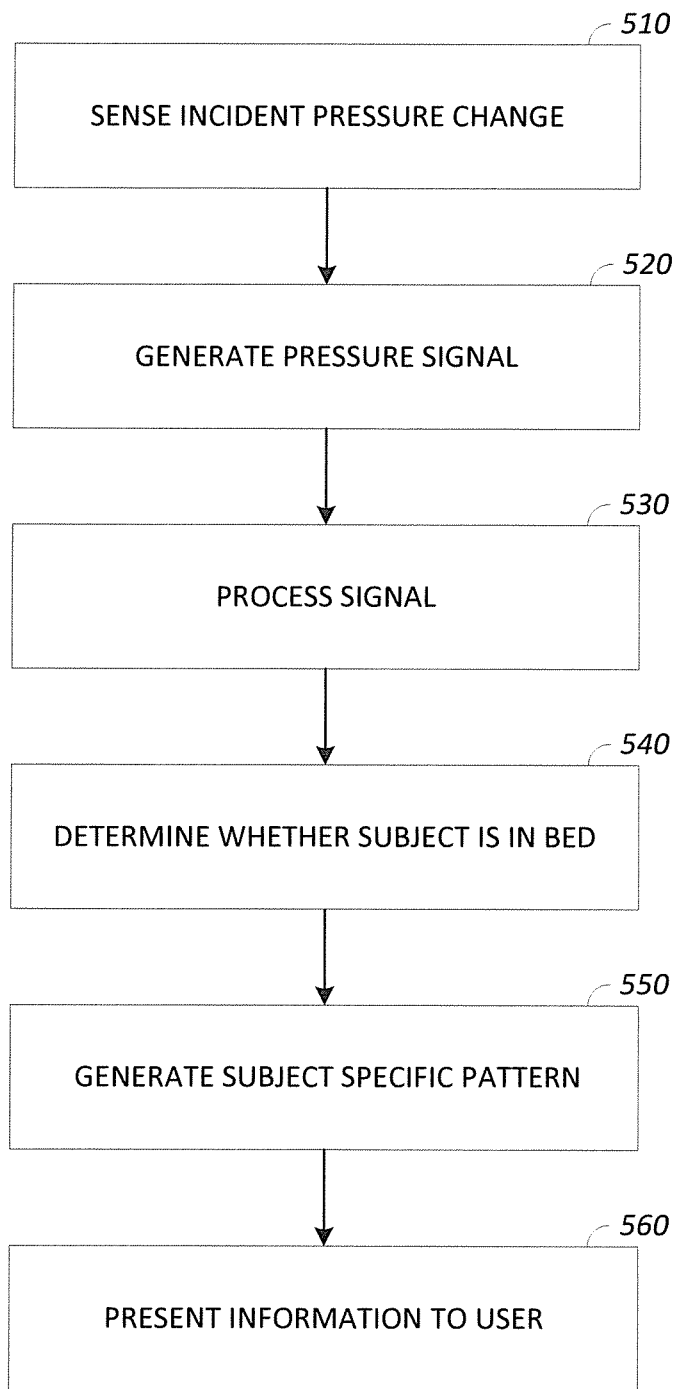

Figure 8

A. CLASSIFICATION OF SUBJECT MATTER**G01S 11/12(2006.01)i, A47C 27/00(2006.01)i**

According to International Patent Classification (IPC) or to both national classification and IPC

B. FIELDS SEARCHED

Minimum documentation searched (classification system followed by classification symbols)

G01S 11/12; A61B 5/08; G06F 17/00; G21K 5/08; A61G 7/057; A47C 27/08; A61B 5/00; A47C 27/00

Documentation searched other than minimum documentation to the extent that such documents are included in the fields searched

Korean utility models and applications for utility models

Japanese utility models and applications for utility models

Electronic data base consulted during the international search (name of data base and, where practicable, search terms used)

eKOMPASS(KIPO internal) & keywords: bladder, fluid, sensor, position, pressure

C. DOCUMENTS CONSIDERED TO BE RELEVANT

Category*	Citation of document, with indication, where appropriate, of the relevant passages	Relevant to claim No.
Y	US 2011-0144455 A1 (YOUNG et al.) 16 June 2011 See abstract, paragraphs [0036]-[0046], claims 1, 14 and figures 1-3.	1-17
Y	US 2008-0189865 A1 (BHAI) 14 August 2008 See abstract, paragraphs [0045], [0070]-[0078], claim 29 and figures 3, 11-12.	1-17
A	US 2012-0043475 A1 (AHN) 23 February 2012 See paragraphs [0102]-[0112], claims 1-5 and figures 1-4.	1-17
A	US 2008-0132808 A1 (LOKHORST et al.) 05 June 2008 See abstract, paragraphs [0049]-[0061] and figures 1-3.	1-17
A	US 2005-0192508 A1 (LANGE et al.) 01 September 2005 See abstract, claims 1-8 and figures 1-3.	1-17

 Further documents are listed in the continuation of Box C. See patent family annex.

* Special categories of cited documents:

"A" document defining the general state of the art which is not considered to be of particular relevance

"E" earlier application or patent but published on or after the international filing date

"L" document which may throw doubts on priority claim(s) or which is cited to establish the publication date of another citation or other special reason (as specified)

"O" document referring to an oral disclosure, use, exhibition or other means

"P" document published prior to the international filing date but later than the priority date claimed

"T" later document published after the international filing date or priority date and not in conflict with the application but cited to understand the principle or theory underlying the invention

"X" document of particular relevance; the claimed invention cannot be considered novel or cannot be considered to involve an inventive step when the document is taken alone

"Y" document of particular relevance; the claimed invention cannot be considered to involve an inventive step when the document is combined with one or more other such documents, such combination being obvious to a person skilled in the art

"&" document member of the same patent family

Date of the actual completion of the international search

24 November 2014 (24.11.2014)

Date of mailing of the international search report

24 November 2014 (24.11.2014)

Name and mailing address of the ISA/KR

International Application Division
Korean Intellectual Property Office
189 Cheongsu-ro, Seo-gu, Daejeon Metropolitan City, 302-701,
Republic of Korea

Facsimile No. +82-42-472-7140

Authorized officer

KANG, Sung Chul

Telephone No. +82-42-481-8405



INTERNATIONAL SEARCH REPORT

Information on patent family members

International application No.

PCT/US2014/047157

Patent document cited in search report	Publication date	Patent family member(s)	Publication date
US 2011-0144455 A1	16/06/2011	EP 2373213 A2	12/10/2011
		JP 2012-514501 A	28/06/2012
		KR 10-2011-0108386 A	05/10/2011
		US 2008-0077020 A1	27/03/2008
		US 2010-0170043 A1	08/07/2010
		US 2010-0174198 A1	08/07/2010
		US 2010-0174199 A1	08/07/2010
		US 8287452 B2	16/10/2012
		US 8444558 B2	21/05/2013
		WO 2010-080794 A2	15/07/2010
		WO 2010-080794 A3	04/11/2010
		WO 2012-061115 A2	10/05/2012
		WO 2012-061115 A3	19/07/2012
		US 2008-0189865 A1	14/08/2008
EP 1893822 A2	05/03/2008		
EP 1912537 A2	23/04/2008		
EP 1912537 A4	07/05/2014		
JP 2008-545513 A	18/12/2008		
JP 5208732 B2	12/06/2013		
US 2010-0063638 A1	11/03/2010		
US 8090478 B2	03/01/2012		
US 8745788 B2	10/06/2014		
WO 2006-135845 A2	21/12/2006		
WO 2006-135845 A3	23/04/2009		
WO 2006-135845 A8	21/12/2006		
WO 2007-016054 A2	08/02/2007		
WO 2007-016054 A3	16/04/2009		
US 2012-0043475 A1	23/02/2012	CA 2705757 A1	28/05/2009
		EP 2211721 A1	04/08/2010
		EP 2211721 A4	08/12/2010
		US 2009-129556 A1	21/05/2009
		US 8002465 B2	23/08/2011
		WO 2009-067428 A1	28/05/2009
US 2008-0132808 A1	05/06/2008	AU 2003-249811 A1	02/02/2004
		CA 2393880 A1	17/01/2004
		CA 2492087 A1	22/01/2004
		EP 1538984 A1	15/06/2005
		JP 2005-532854 A	04/11/2005
		JP 4575155 B2	04/11/2010
		US 2006-0152378 A1	13/07/2006
		US 7825814 B2	02/11/2010
		WO 2004-006768 A1	22/01/2004
		US 2005-0192508 A1	01/09/2005
AU 2006-260535 A2	21/02/2008		
CA 2613460 A1	28/12/2006		

INTERNATIONAL SEARCH REPORT

Information on patent family members

International application No.

PCT/US2014/047157

Patent document cited in search report	Publication date	Patent family member(s)	Publication date
		CA 2613460 C	08/05/2012
		CN 101365373 A	11/02/2009
		EP 1786315 A2	23/05/2007
		EP 1786315 A4	03/03/2010
		EP 1898777 A2	19/03/2008
		EP 2505131 A1	03/10/2012
		JP 2007-537777 A	27/12/2007
		JP 2009-501557 A	22/01/2009
		JP 4809779 B2	09/11/2011
		JP 5155856 B2	06/03/2013
		KR 10-1182994 B1	19/09/2012
		US 2006-0170501 A1	03/08/2006
		US 2006-0224076 A1	05/10/2006
		US 2006-0241510 A1	26/10/2006
		US 2008-0114260 A1	15/05/2008
		US 2008-0269625 A1	30/10/2008
		US 2011-0015535 A1	20/01/2011
		US 7077810 B2	18/07/2006
		US 7279978 B2	09/10/2007
		US 7314451 B2	01/01/2008
		US 8376954 B2	19/02/2013
		US 8403865 B2	26/03/2013
		US 8517953 B2	27/08/2013
		WO 2005-074361 A2	18/08/2005
		WO 2005-074361 A3	23/04/2009
		WO 2006-137067 A2	28/12/2006
		WO 2006-137067 A3	27/09/2007

专利名称(译)	监测位置和预测对象在基板上或从基板上退出的装置和方法		
公开(公告)号	EP3022581A1	公开(公告)日	2016-05-25
申请号	EP2014826333	申请日	2014-07-18
[标]申请(专利权)人(译)	BAM LABS		
申请(专利权)人(译)	BAM实验室, Inc.		
当前申请(专利权)人(译)	SLEEPIQ LABS公司.		
[标]发明人	YOUNG STEVEN J HEWITT CARL LUCKOW AL		
发明人	YOUNG, STEVEN J. HEWITT, CARL LUCKOW, AL		
IPC分类号	G01S11/12 A47C27/00 A61B5/00 A61B5/0205 A61B5/024 A61B5/08 A61B5/11		
CPC分类号	A61B5/746 A61B5/0002 A61B5/0022 A61B5/0205 A61B5/024 A61B5/0816 A61B5/1115 A61B5/1116 A61B5/1117 A61B5/6891 A61B5/6892 A61B5/6894 A61B5/7275 A61B2562/0247		
代理机构(译)	康罗伊, JOHN		
优先权	13/945554 2013-07-18 US		
其他公开文献	EP3022581A4		
外部链接	Espacenet		

摘要(译)

公开了用于监测受试者位置的方法和装置。一种这样的方法包括感测由对象在包括交错部分的分开的囊上移动而产生的压力波，产生指示每个交错部分的压力波的信号，并将信号发送到处理器。该方法还包括基于来自每个交错部分的信号之间的差异来确定对象的位置，并为对象生成图案。该模式包括受试者随时间的存在和/或位置。该方法还包括基于将对象的当前模式与对象的先前模式进行比较来预测诸如对象从分开的膀胱中退出的动作。