

(19) World Intellectual Property Organization
International Bureau



(43) International Publication Date
29 June 2006 (29.06.2006)

PCT

(10) International Publication Number
WO 2006/069013 A1

(51) International Patent Classification:
A61B 18/00 (2006.01) A61M 25/09 (2006.01)

(74) Agents: CHRISTOPHER, John et al.; Christopher & Weisberg, P.A., 200 East Las Olas Boulevard, Suite 2040, Fort Lauderdale, Florida 33301 (US).

(21) International Application Number:
PCT/US2005/045989

(81) Designated States (unless otherwise indicated, for every kind of national protection available): AE, AG, AL, AM, AT, AU, AZ, BA, BB, BG, BR, BW, BY, BZ, CA, CH, CN, CO, CR, CU, CZ, DE, DK, DM, DZ, EC, EE, EG, ES, FI, GB, GD, GE, GH, GM, HR, HU, ID, IL, IN, IS, JP, KE, KG, KM, KN, KP, KR, KZ, LC, LK, LR, LS, LT, LU, LV, LY, MA, MD, MG, MK, MN, MW, MX, MZ, NA, NG, NI, NO, NZ, OM, PG, PH, PL, PT, RO, RU, SC, SD, SE, SG, SK, SL, SM, SY, TJ, TM, TN, TR, TT, TZ, UA, UG, US, UZ, VC, VN, YU, ZA, ZM, ZW.

(22) International Filing Date:
16 December 2005 (16.12.2005)

(25) Filing Language: English

(26) Publication Language: English

(30) Priority Data:
11/021,113 22 December 2004 (22.12.2004) US

(84) Designated States (unless otherwise indicated, for every kind of regional protection available): ARIPO (BW, GH, GM, KE, LS, MW, MZ, NA, SD, SL, SZ, TZ, UG, ZM, ZW), Eurasian (AM, AZ, BY, KG, KZ, MD, RU, TJ, TM), European (AT, BE, BG, CH, CY, CZ, DE, DK, EE, ES, FI, FR, GB, GR, HU, IE, IS, IT, LT, LU, LV, MC, NL, PL, PT, RO, SE, SI, SK, TR), OAPI (BF, BJ, CF, CG, CI, CM, GA, GN, GQ, GW, ML, MR, NE, SN, TD, TG).

(71) Applicant (for all designated States except US): CRY-OCATH TECHNOLOGIES INC. [CA/CA]; 16771 Chemin Ste-Marie, Kirkland, Quebec, H9H 5H3 (CA).

(72) Inventors: KANIA, Wlodzimierz; 76 Eastview Avenue, Pointe-Claire, Quebec H9R 5N7 (CA). CARROLL, Sean; 6042 Stephens Place, Rancho Cucamonga, CA 91739 (US). SKANES, Allan, Dr.; 90 Carriage Hill Drive, London, Ontario N5X 3W9 (CA).

Published:
— with international search report
— before the expiration of the time limit for amending the claims and to be republished in the event of receipt of amendments

(72) Inventor; and
(75) Inventor/Applicant (for US only): LANE, Miriam [US/CA]; 14 rue Middleton, Dollard-des-Ormeaux, Québec, H9A 1T2 (CA).

For two-letter codes and other abbreviations, refer to the "Guidance Notes on Codes and Abbreviations" appearing at the beginning of each regular issue of the PCT Gazette.

(54) Title: TISSUE ABLATION SYSTEM INCLUDING GUIDEWIRE WITH SENSING ELEMENT

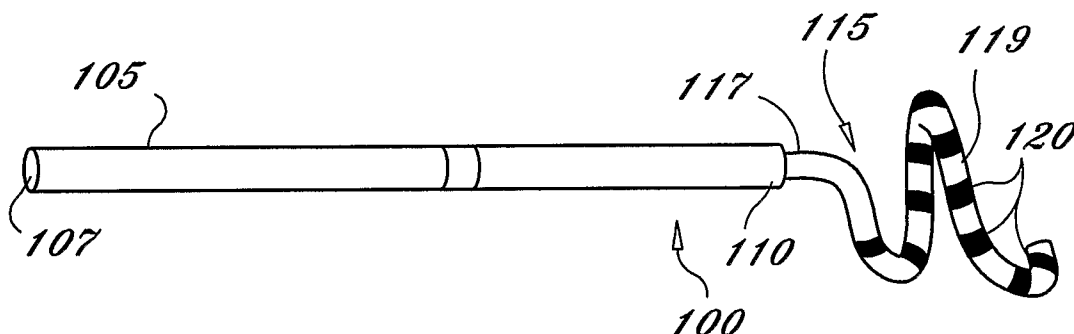

(57) Abstract: A tissue ablation system for ablating human tissue wherein sensing and ablation procedures are performed and controlled independently. A sensing wire is positioned distally to the ablation region and is adapted to pass through the ablation device such that it may move with or independently of the ablation device without obstructing the surface tissue interface of the ablation energy. The ablation device can ablate a substantial portion of a circumferential region of tissue, for example at or near the location where the pulmonary vein extends from the atrium. The tissue ablation system comprises an ablation device comprised of an elongated catheter with a proximal region and a distal region and an ablation element located proximate the distal region of the catheter. A sensing device having an elongated body with a proximal portion and a distal portion is adapted to be positioned within a vessel at or near a vessel ostium, wherein the sensing device is adapted to be slidably received within a lumen of the ablation device. The sensing device, a guide wire for example, may be shaped in various configurations to allow sensing device such as electrodes disposed thereon to contact the vessel wall near the ablation region. In this fashion, the sensing and ablation procedures are de-coupled such that the sensing device does not interfere or obstruct the ablation member's interface with the tissue



WO 2006/069013 A1

**TISSUE ABLATION SYSTEM INCLUDING
GUIDEWIRE WITH SENSING ELEMENT**

TECHNICAL FIELD

The present invention relates to medical systems and more particularly to a movable
5 sensor system for tissue ablation.

BACKGROUND INFORMATION

Many tissue ablation devices and methods have been developed for both diagnosis
and for treating the various symptoms of abnormal heart rhythms, generally referred to as
cardiac arrhythmias. The present invention is concerned with electrical isolation of
10 anatomical structure, such as isolating the pulmonary veins from the left atrium for treatment
of atrial fibrillation. Cardiac arrhythmias, and atrial fibrillation in particular, persist as
common and dangerous medical ailments associated with abnormal cardiac chamber wall
tissue and are often observed in the elderly.

Detailed examples of these ablation devices used for electrically isolating the
15 pulmonary vein and methods for creating lesions are disclosed in U.S. Patent Nos. 6,012,457
to Lesh; 6,164,283 to Lesh; 6,245,064 to Lesh; 6,245,599 to Lesh; 6,241,754 to Swanson; and
6,325,797 to Stewart.

Cardiac arrhythmias, including atrial fibrillation, may generally be detected using the
global technique of an electrocardiogram (EKG). More sensitive procedures of mapping the
20 specific conduction along the cardiac chambers have also been disclosed, such as, for
example, in U.S. Patent Nos. 5,500,011 to Desai; 5,657,755 to Desai; 5,555,883 to Avitall;
5,156,151 to Imran; 6,292,695 to Webster; and 6,064,905 to Webster. These devices are
often coupled to an ablation device. For example, Patent Application No. WO 00/51683
("the '683 application") teaches the concept of using sensors mounted on an expandable
25 member to achieve surface contact for mapping and ablation control. As has been described
above, mapping using electrical signals identifies electrical isolation by comparing electrical
signal propagation. The ideal ablation target may be the atrial tissue surrounding the
Pulmonary Vein ostium. In such a situation, to adequately map, the electrodes should be
positioned distal to the ablation location and inside the Pulmonary Vein, and not at the actual
30 ablation site as taught in the '683 application.

With an increased emphasis on anatomical approaches to ablation and ablation at or
near an ostium, there exists a need to de-couple the sensing technology used for mapping,
from the ablation device such that the sensor does not obstruct the ablation member from

engaging the tissue during the ablation procedure. Further, none of the above teaches the flexibility of using two devices with a single transseptal puncture to access the left atrium.

It is desirable, therefore, to provide a system that combines mapping and sensing capabilities with an ablation device wherein the sensing portion of the system is operated
5 independently of the ablation portion and does not interfere with the ablation device in contact with the surface of the treated tissue

SUMMARY OF THE INVENTION

The present invention advantageously provides a method and system for ablating a circumferential region of tissue wherein a sensing wire is positioned distally to the ablation
10 region and passes thorough the ablation device such that it may move with or independently of the ablation device without obstructing the surface-tissue interface.

In one embodiment, the present invention is a medical device having a sensor and a device body, wherein the sensor is movable with respect to the device body. In another embodiment, the invention comprises a method of positioning a sensor with respect to an
15 ablation element wherein the sensor and ablation element are part of a single ablation device.

According to one aspect, the invention comprises a sensing device and an ablation device. The ablation device includes an ablation member that ablates a substantial portion of a circumferential region of human tissue such as the location where the pulmonary vein extends from the atrium. The ablation device includes an elongated body with a proximal
20 end portion and a distal end portion. The ablation member is coupled to the elongated body such that the ablation member may be adjustable from a collapsed state to an expanded position. The adjustable ablation member is adapted to engage the substantial portion of circumferential region of tissue when in the expanded position.

According to another aspect of the present invention, a tissue ablation system is
25 provided for ablating a region of tissue. The system comprises a treatment device, such as, for example, a probe or catheter, having a proximal region and a distal region and a treatment element located proximate the distal region of the treatment device. The system also includes a sensing device having a body with a proximal portion and a distal portion. The sensing device is preferably adapted to be positioned within a vessel and is adapted to be slidably
30 received within a lumen of the treatment device.

According to another aspect of the invention, a tissue ablation system for ablating a region of tissue is provided. The system includes an ablation device comprised of an elongated catheter with a proximal region and a distal region and an ablation element located proximate the distal region of the catheter, and a sensing device having an elongated body

with a proximal portion and a distal portion. The sensing device is positioned within a vessel and is adapted to be slidably received within a lumen of the ablation device. The sensing device is adapted to slidably track side by side with the ablation device through a sheath such that the ablation element maintains engagement with the tissue when the sensing device is
5 slidably received within the lumen of the ablation device.

According to yet another embodiment or aspect of the invention, the invention comprises a sensing device having an elongated body with a proximal end portion and a distal end portion. The elongated body is adapted to be positioned within a vessel and positionable through another device. The distal end portion is configured to sense ECG
10 signals in a circumferential region inside a vessel lumen.

According to still another aspect of the invention, the invention comprises a tissue treatment system for treating a region of tissue. The tissue treatment system comprises a treatment device comprised of an elongated catheter with a proximal region and a distal region and a treatment element located proximate the distal region of the catheter, and a
15 sensing device adapted to be positioned within a vessel or at or near a vessel opening. The sensing device is adapted to be slidably received within a lumen of the treatment device, and the sensing device is also adapted to slidably track side by side with the treatment device through a sheath such that the treatment element maintains engagement with the tissue when the sensing device is slidably received within the lumen of the treatment device.

Additional aspects of the invention will be set forth in part in the description which
20 follows, and in part will be obvious from the description, or may be learned by practice of the invention. The aspects of the invention will be realized and attained by means of the elements and combinations particularly pointed out in the appended claims. It is to be understood that both the foregoing general description and the following detailed description
25 are exemplary and explanatory only and are not restrictive of the invention, as claimed.

Brief Description of the Drawings

A more complete understanding of the present invention, and the attendant advantages and features thereof, will be more readily understood by reference to the following detailed description when considered in conjunction with the accompanying drawings wherein:

30 FIG. 1 is a side view of the tissue ablation device of the present invention;

FIGS. 2A – 2C illustrate side views of the sensing device utilized in the present invention;

FIG. 3A is a side view of an alternate embodiment of the tissue ablation device of the present invention illustrating the use of the sensing device with a balloon catheter;

FIG. 3B is a side view of yet another embodiment of the tissue ablation device of the present invention illustrating the use of the sensing device with a balloon catheter; and

FIG. 4 is a side view of a further embodiment of the tissue ablation device of the present invention.

5 FIG. 5 is a side view of yet a further embodiment of the tissue ablation device of the present invention.

Detailed Description of the Invention

The present invention is a medical device that provides both electrical sensing and ablation capabilities in a single device. To insure that the ablation element provides
10 sufficient circumferential contact with the target tissue ablation region, the sensing element of the device is positioned distally from the ablation element. In the preferred embodiment, the sensing element is a guide wire positioned within a lumen in the ablation device, comprises one or more electrodes. The electrodes can provide critical mapping information without
15 hindering the ablation procedure, due to their location distally on the guidewire itself and not on the ablation element. Thus, the present invention provides a system that can allow for sensing and ablation procedures to be performed with only a single transeptal puncture.

As used herein, the term "cryogen" or "cryogenic fluid" refers to a fluid substance with properties suitable for: (i) steady flow through ducts of small diameter, (ii) high pressure compression into liquid phase, and (iii) evaporation and expansion to gas phase at low
20 temperatures, typically at saturation temperature or in the range of -10 to -130 degrees centigrade. The cryogen may be any suitable, relatively inert "working fluid", such as nitrogen, nitrous oxide, or carbon dioxide, or refrigerants such as chlorodifluoromethane, ethyl alcohol, or Freon (a trademark of DuPont), or any number of other refrigerants or fluids with a high thermal energy transfer capacity and low boiling point, as are commonly known
25 to those skilled in the art.

Also as used herein, the term "catheter" refers to a medical device composed of any number of tubes and ancillary structures, for insertion into canals, vessels, passageways or other body cavities to permit the treatment of body tissue proximate to the catheter. A
30 catheter may be constructed from a variety of suitable materials having a varying range of structural and thermal properties. It is understood that the particular structural, dimensional, and/or thermal properties of a catheter included in the present invention may considerably vary depending on the particular application of the device disclosed herein.

Referring now to the drawings, in which like reference designators refer to like elements, there is shown in FIG. 1 a tissue ablation device in accordance with the present

invention, and designated generally as 100. An ablation device, such as a probe or a catheter 105, has an ablation member (catheter tip) 107 at its distal end, which may be used for various types of ablation procedures. The proximal end of the catheter 105 is accessible to a surgeon and is connectable to a refrigerant source (not shown). The catheter 105 is
5 preferably semi-rigid and flexible so as to be readily steerable to a desired location in a patient's body, in order, for example, to isolate the pulmonary vein from the left atrium in a patient's heart for treatment of such conditions as atrial fibrillation and cardiac arrhythmias.

The present invention may be used with all types of ablation catheters including cryocatheters and radiofrequency catheters. Catheters that carry out microwave, RF ablation,
10 cool-tip RF ablation, thermal ablation and laser ablation procedures are also contemplated. In the preferred embodiment, the ablation device is a cryocatheter.

The ablation catheter 105 supplies cryogen to the desired location. The cryogen supplied may be either in a liquid or a gaseous state. The cryogen is cooled and/or compressed to a predetermined initial temperature and initial pressure before introduction
15 into the catheter 105. The catheter 105 contains multiple inner tubes (not shown), preferably made of flexible or rigid material such a polymer, fiber, metal, or any combination thereof. The tubes are arranged to create a plurality of lumens (not shown) for the flow of cryogen therethrough. These lumens are arranged to create a circulation path for the flow of cryogen through the device. This includes an injection lumen (not shown) through which the cryogen
20 is introduced into the catheter 105 to flow from a cryogen supply through to the ablation member 107, and a return lumen (not shown), through which cryogen eventually flows back to a controller unit from the catheter tip 107. The initial supply pressure of the cryogen is preferably on the order of 30 to 40 atmospheres, or 400 to 600 psia, much higher than the eventual final pressure in the vacuum return lumen. The resultant negative pressure gradient
25 drives the high pressure cryogen drawn from the supply to flow through an injection lumen in catheter 105, to the catheter tip 107, and thereafter to flow back through the return lumen. Such catheter delivery systems are well known to those of ordinary skill in the art.

The ablation device is coupled to a sensing device having an elongated body with a proximal portion and a distal portion. The elongated body of the sensing device is typically
30 between 0.014 inches to 0.042 inches in diameter and between 80 and 320 cm long, although this range is only an example and various-sized sensing devices may be used. The sensing device is positioned within a vessel and is adapted to be slidably received within a lumen in the ablation device. The sensor may, for example, be positioned at or near a vessel ostium. The sensing device can detect pressure, electrical activity, temperature or other characteristics

such as impedance, necessary to provide mapping data to a user, in order to perform ablation procedures.

The sensing device preferably contains one or more electrodes 120 disposed about its exterior surface. One example of a sensing device compatible with the present invention is a
5 guide wire 115. Catheter 105 is guided to the desired treatment site via guide wire 115. Referring to FIG. 1, guide wire 115 has a distal end 117 and a proximal end 119. Guide wire 115 is used to manipulate the catheter 105 through the patient's body to the ablation site. The guide wire 115 and the catheter 105 may be positioned within a vessel to ablate a substantial
10 portion of the circumferential region of tissue at or near the location where the pulmonary vein extends from the atrium. The guide wire 115 is distal from catheter 105 and is slidably received within a lumen in catheter 105. Guide wire 115 can be separately controlled to move with or independently from catheter 105.

One or more electrodes 120 are positioned circumferentially around guide wire 115. Electrodes 120 provide mapping and sensing capabilities and are positioned distal from
15 catheter 105 to assure that the sensing device does not interfere with catheter tip 107. Because guide wire 115 is slidably received within catheter 105, and is positioned distally from catheter 105, the guide wire does not obstruct the interface between the ablation member and the target surface tissue.

FIGS. 2A-2C illustrate various embodiments of guide wire 115. FIG. 2A illustrates
20 guide wire 115 in a generally straight, circumferential shape located at the distal end of catheter 105 (not shown). The circumferential shape can be formed by various methods including inserting a pre-shaped inner member comprised of shape-memory material within the guide wire, activating a pull wire, or by removal of a stylet or other means known to those skilled in the art.

FIGS. 2B and 2C illustrate two of the various shapes that can be formed by
25 controlling guide wire 115 to contact human tissue in various locations in the body. Once again, electrodes 120 can be positioned so as to contact tissue in difficult-to-reach locations in the patient in order to provide mapping information for ablation procedures. Various loops and circular configurations can be formed to allow electrodes 120 on guide wire 115 to touch
30 the desired tissue region, for example the pulmonary vein or coronary sinus wall, in a number of locations around the circumference of the vein.

In an alternate embodiment, the guide wire 115 can be independently controlled and adjusted from a first, straight state, to a second, coiled orientation to allow electrodes 120 to radially contact the tissue of a blood vessel wall. For example, the sensing device 115 may
35 be comprised of expandable, "balloon-like" material with the electrodes 120 disposed on the

balloon. The balloon can be expanded to contact the vessel wall in a number of different locations to perform mapping procedures.

The catheter 105 may be pre-shaped to circumferentially engage the vessel wall or deflected to engage the vessel wall. Methods such as the use of a pull-wire may be used to
5 cause the ablation device 105 to deflect to produce various shapes. By deflecting the ablation device, a catheter 105 may be re-directed in more than one direction in a single plane, as well as in more than one plane, to engage tissue in the target ablation region.

In one embodiment of the present invention, catheter 105 may be adjusted between a radially collapsed configuration and a radially expanded configuration. As described above,
10 for the sensing device the ablation device may also be comprised of balloon-like material. FIG. 3A illustrates a balloon catheter 106 coupled to a guide wire 115 having sensing electrodes 120 around its outer circumference. Balloon catheter 106 has one or more expandable balloon portions 109 to engage the tissue of the patient at or near the vessel ostium or inside a vessel. The balloon portion 109 maintains its engagement with the tissue
15 while the sensing device is slidably received within the lumen of the balloon catheter 106.

The specific size and shape of the balloon portion 109 may be determined prior to use to best fit the targeted vessel where an ablation or treatment procedure is to be performed. Balloon catheter 106 is inflated so that a balloon portion 109 contacts the inner walls of the blood vessel proximate the ablation area. The balloon portion 109 is comprised of a flexible,
20 expandable membrane and is coupled to a catheter tube 108, wherein the balloon catheter 106 is guided to the desired treatment site via guide wire 115. The particular shape of the expanded balloon portion 109 may be predetermined by the use of a preformed balloon membrane, a memory retaining material, or other structural attribute wherein the expanded balloon portion 107 is configured to form a particular shape, yet also remain somewhat
25 conformable.

FIG. 3B illustrates another embodiment of the present invention. In this embodiment, a sheath 125 is provided with a compliant, inflatable balloon portion 109 on its distal end. The flexible balloon portion 109 at the distal end of the sheath allows for the forming of different shapes within the vessel. Side holes 130 may be provided proximal to balloon
30 portion 109 to allow for perfusion through the center of the balloon. This allows the balloon to remain inflated and to maintain perfusion throughout the ablation process performed by the AC cooling segment 135.

The benefit of the embodiment depicted in FIG. 3B is that the heat load flowing through the vessel to the target tissue is diminished due to the effects of the inflated balloon

109. Cooling segment 135 can now freeze the target tissue more effectively due to the reduced heat load and more efficient heat transfer to the target tissue.

FIG. 4 shows a further embodiment of the present invention. Catheter 105 forms the shape of a loop at its distal end. Guide wire 115 passes through the distal loop portion of catheter 105. By employing differently shaped sensing devices and ablation devices a series of independently controlled mapping and ablation procedures can take place. The present invention allows for independent control of each procedure while maintaining the sensing device at a distance from the ablation device. In this fashion the sensing device, or guide wire, which passes through the interior portion of the ablation device, does not interfere with the catheter tip's engagement with the vessel wall during the ablation procedure.

FIG. 5 illustrates yet another embodiment of the present invention. A balloon catheter 106 is coupled to a guidewire 115 having one or more electrodes 120. In this embodiment, the expandable portion of the balloon catheter acts to decrease blood flow through a cavity while at least one electrode detects electrical activity, both of which act to facilitate cryoablation. Side holes 130 may be provided proximal to balloon portion 109 to allow for perfusion through the center of the balloon. This allows the balloon to remain inflated and to maintain perfusion throughout the ablation process.

The present invention is equally adaptable with various different types of ablation devices including but not limited to microwave, ultrasound and RF ablation elements, cryogenic ablation elements, thermal ablation elements, light-emitting ablation elements, ultrasound transducers and other substance delivery elements.

It will be appreciated by persons skilled in the art that the present invention is not limited to what has been particularly shown and described herein above. In addition, unless mention was made above to the contrary, it should be noted that all of the accompanying drawings are not to scale. A variety of modifications and variations are possible in light of the above teachings without departing from the scope and spirit of the invention, which is limited only by the following claims.

CLAIMS

What is claimed is:

1. A medical device having a sensor and a device body, wherein the sensor is movable with respect to the device body.
2. The medical device of claim 1 wherein the device body is a treatment element.
3. The medical device of claim 2 wherein the treatment element is a probe.
4. The medical device of claim 2 wherein the treatment element is a catheter.
5. The medical device of claim 4 wherein the catheter is a balloon-catheter.
6. The medical device of claim 1 wherein the sensor is an electrocardiogram sensor.
7. The medical device of claim 1 wherein the sensor is an electrical sensor.
8. The medical device of claim 1 wherein the sensor detects impedance.
9. The medical device of claim 1 wherein the sensor detects pressure.
10. The medical device of claim 1 wherein the sensor detects temperature.
11. The medical device of claim 1 wherein the sensor detects two or more parameters selected from the group consisting of temperature, pressure, impedance, and electricity.
12. A tissue ablation system for ablating a region of tissue, the system comprising:
a treatment device having a proximal region and a distal region and a treatment element located proximate the distal region of the treatment device; and
a sensing device having a body with a proximal portion and a distal portion, the sensing device adapted to be positioned within a vessel, wherein the sensing device is adapted to be slidably received within a lumen of the treatment device.

13. The tissue ablation system of claim 12 wherein the treatment element is selected from the group consisting of a microwave ablation element, cryogenic ablation element, thermal ablation element, light-emitting ablation element, RF ablation element, ultrasound transducer, and substance delivery element.
14. The tissue ablation system of claim 12 where the treatment device is comprised of an elongated catheter with a proximal region and a distal region and an ablation element located proximate the distal region of the catheter.
15. The tissue ablation system of claim 12 where the sensing device is positioned distal to the treatment element.
16. The tissue ablation system of claim 12 where the treatment element is adjustable between a radially collapsed configuration and a radially expanded configuration.
17. The tissue ablation system of claim 16 where the treatment element includes one or more inflatable balloons.
18. The tissue ablation system of claim 12 wherein the treatment element engages the tissue at or near a vessel ostium.
19. The tissue ablation system of claim 18 wherein the treatment element maintains engagement with the tissue when the sensing device is slidably received within the lumen of the treatment device.
20. The tissue ablation system of claim 17 where the treatment element is pre-shaped to circumferentially engage the tissue at or near the vessel ostium.
21. The tissue ablation system of claim 18 where the treatment element is deflected to circumferentially engage the tissue at or near the vessel ostium.
22. The tissue ablation system of claim 12 where the sensing device is comprised of one or more electrodes.
23. The tissue ablation system of claim 12 wherein the distal portion of the sensing device is adjustable from a collapsed state to an expanded position to radially engage a wall of the vessel.

24. The tissue ablation system of claim 23 wherein the adjustable distal portion allows the sensing device to contact the tissue.
25. The tissue ablation system of claim 12 wherein the sensing device forms a circumferential shape.
26. The tissue ablation system of claim 25 wherein the circumferential shape is achieved by activating a pull wire.
27. The tissue ablation system of claim 25 wherein the circumferential shape is achieved by inserting a pre-shaped inner member within the sensing device.
28. The tissue ablation system of claim 27 wherein the pre-shaped inner member is comprised of shape memory material.
29. The tissue ablation system of claim 25 where the circumferential shape is achieved by removal of a stylet.
30. The tissue ablation system of claim 12 wherein the lumen of the treatment device is a guidewire lumen.
31. The tissue ablation system of claim 12 wherein the elongated body of the sensing device has an outer diameter of approximately 0.014 to 0.042 inches.
32. The tissue ablation system of claim 12 wherein the treatment device is in the shape of a loop and the sensing device passes through the loop's interior.
33. The tissue ablation system of claim 12 wherein the system requires only a single transseptal puncture.
34. The tissue ablation system of claim 12 wherein the sensing device measures pressure.
35. The tissue ablation system of claim 12 wherein the sensing device is an electrocardiogram sensor.

36. The tissue ablation system of claim 12 wherein the sensing device detects impedance.
37. A tissue ablation system for ablating a region of tissue, the system comprising: an ablation device comprised of an elongated catheter with a proximal region and a distal region and an ablation element located proximate the distal region of the catheter; and a sensing device having an elongated body with a proximal portion and a distal portion, the sensing device adapted to be positioned within a vessel or at or near a vessel ostium, wherein the sensing device is adapted to be slidably received within a lumen of the ablation device, wherein the sensing device is adapted to slidably track side by side with the ablation device through a sheath such that the ablation element maintains engagement with the tissue when the sensing device is slidably received within the lumen of the ablation device.
38. The tissue ablation system of claim 37 where the sensing device is positioned distal to the ablation element.
39. The tissue ablation system of claim 37 where the ablation device is pre-shaped to circumferentially engage the tissue at or near the vessel ostium.
40. The tissue ablation system of claim 39 wherein the ablation device is pre-shaped using shape memory materials.
41. The tissue ablation system of claim 37 where the ablation device is deflected to circumferentially engage the tissue at or near the vessel ostium.
42. The tissue ablation system of claim 37 wherein the ablation device is in the shape of a loop and the sensing device passes through the loop's interior.
43. The tissue ablation system of claim 37 wherein the distal portion of the sensing device is adjustable from a collapsed state to an expanded state to radially engage a wall of the vessel.
44. The tissue ablation system of claim 43 wherein the adjustable distal portion allows the sensing device to contact the tissue.

45. The tissue ablation system of claim 37 where the sensing device is comprised of one or more electrodes.

46. The tissue ablation system of claim 37 wherein the sensing device forms a circumferential shape.

47. The tissue ablation system of claim 46 wherein the circumferential shape is achieved by activating a pull wire.

48. The tissue ablation system of claim 46 wherein the circumferential shape is achieved by inserting a pre-shaped inner member within the sensing device.

49. The tissue ablation system of claim 48 wherein the pre-shaped inner member is comprised of shape memory material.

50. The tissue ablation system of claim 46 where the circumferential shape is achieved by removal of a stylet.

51. The tissue ablation system of claim 37 wherein the system requires only a single transeptal puncture.

52. The tissue ablation system of claim 37 wherein the lumen of the ablation device has a proximal port and a distal port, the proximal port being proximal to the ablation device and the distal port being distal to the ablation device.

53. The tissue ablation system of claim 37 wherein the elongated body has an outer diameter of approximately 0.014 to 0.042 inches.

54. The tissue ablation system of claim 37 wherein the sensor is an electrical sensor.

55. The tissue ablation system of claim 37 wherein the sensor is an electrocardiogram sensor.

56. The tissue ablation system of claim 37 wherein the sensing device measures pressure.

57. The tissue ablation system of claim 37 wherein the sensing device measures temperature.
58. The tissue ablation system of claim 37 wherein the sensing device measures impedance.
59. The tissue ablation system of claim 37 wherein the ablation element is selected from the group consisting of a microwave ablation element, cryogenic ablation element, thermal ablation element, light-emitting ablation element, RF ablation element, ultrasound transducer, and substance delivery element.
60. A sensing device having an elongated body with a proximal end portion and a distal end portion, the elongated body adapted to be positioned within a vessel and positionable through another device.
61. The sensing device of claim 60 wherein the distal end portion is adjustable from a collapsed position to an expanded position to radially engage a wall of the vessel.
62. The sensing device of claim 60 wherein the adjustable distal portion allows the sensing device to contact the tissue.
63. The sensing device of claim 60 wherein the sensing device is comprised of one or more electrodes.
64. The sensing device of claim 60 wherein the sensing device forms a circumferential shape.
65. The sensing device of claim 64 wherein the circumferential shape is achieved by actuating a pull-wire.
66. The sensing device of claim 64 wherein the circumferential shape is achieved by inserting a pre-shaped inner member within the sensing device.
67. The sensing device of claim 66 wherein the pre-shaped inner member is comprised of shape memory material.
- .

68. The sensing device of claim 64 where the circumferential shape is achieved by removal of a stylet.

69. The sensing device of claim 64 wherein the elongated body has an outer diameter of approximately 0.014 to 0.042 inches.

70. The sensing device of claim 60 wherein the sensing device measures pressure.

71. The sensing device of claim 60 wherein the sensing device measures temperature.

72. The sensing device of claim 60 wherein the sensing device measures impedance.

73. The sensing device of claim 60 wherein the sensing device is an electrical sensor.

74. The sensing device of claim 60 wherein the sensing device is an electrocardiogram sensor.

75. A method of independently positioning a sensor with respect to an ablation element wherein the sensor and ablation element are part of a single device.

76. A tissue treatment system for treating a region of tissue, the system comprising:

a treatment device comprised of an elongated catheter with a proximal region and a distal region and a treatment element located proximate the distal region of the catheter; and
a sensing device adapted to be positioned within a vessel or at or near a vessel opening, wherein the sensing device is adapted to be slidably received within a lumen of the treatment device, wherein the sensing device is adapted to slidably track side by side with the treatment device through a sheath such that the treatment element maintains engagement with the tissue when the sensing device is slidably received within the lumen of the treatment device.

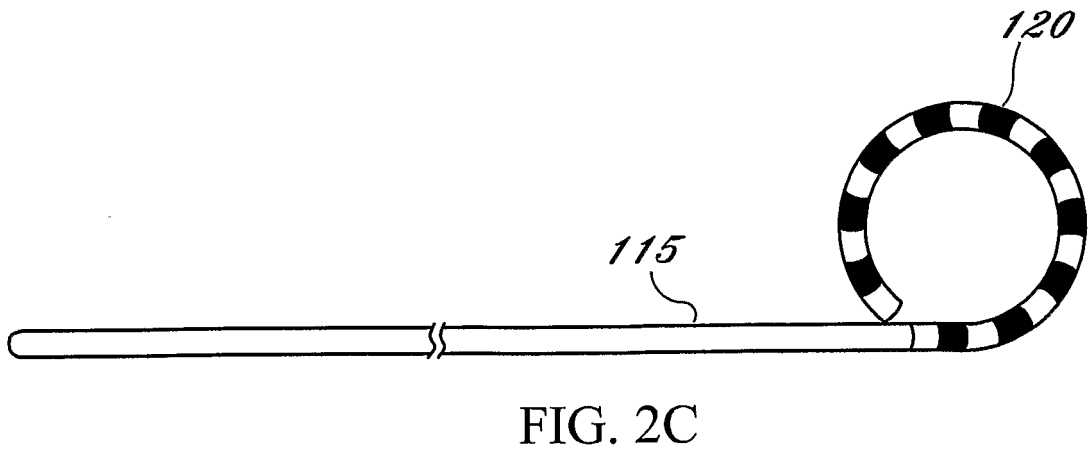
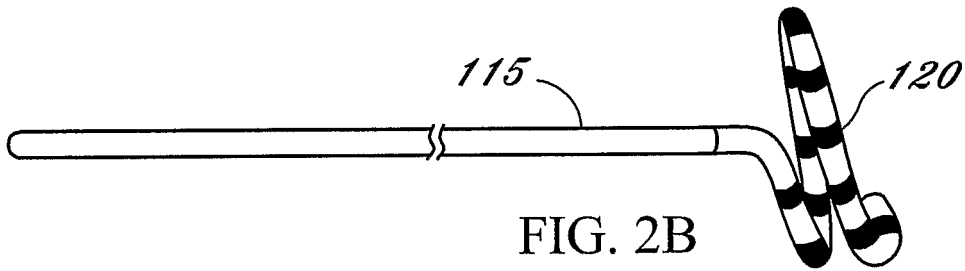
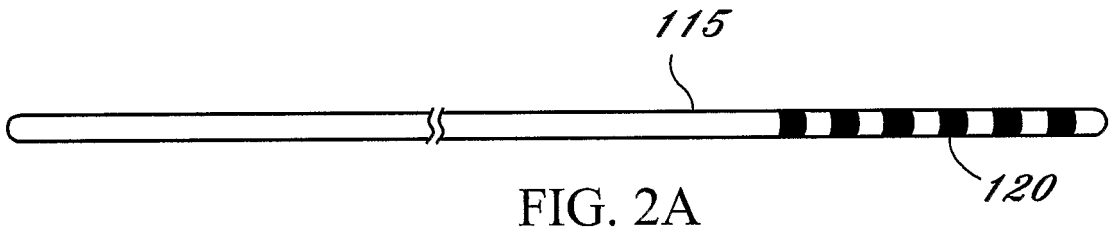
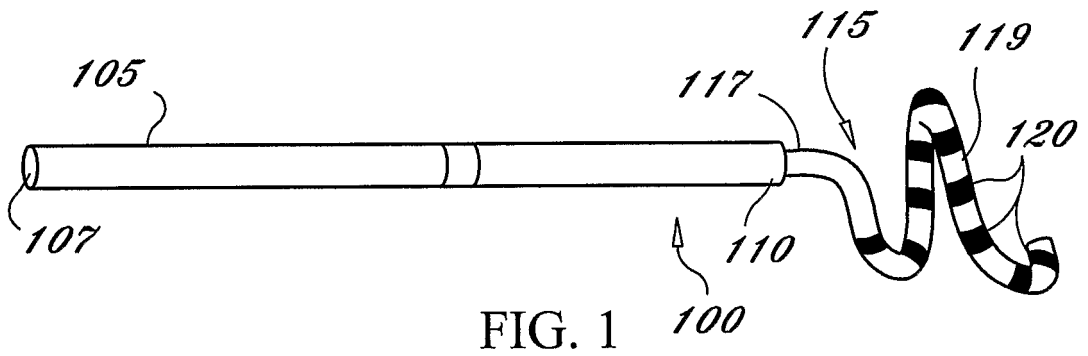

2/3

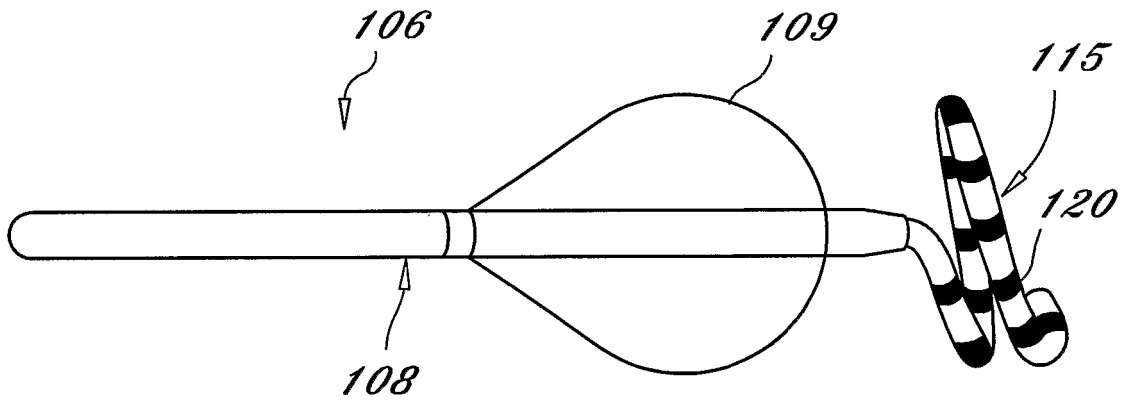

FIG. 3A

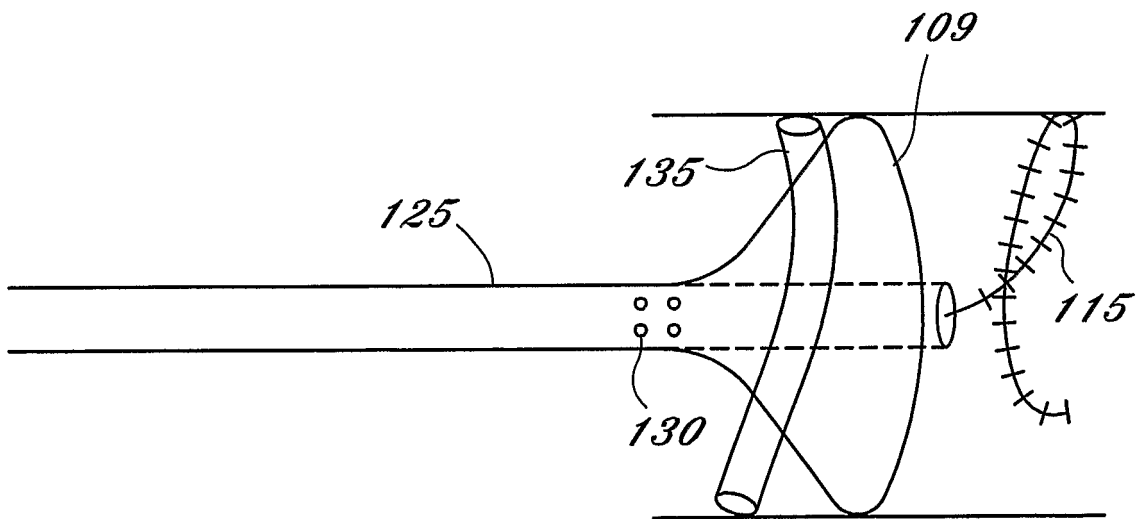

FIG. 3B

3/3

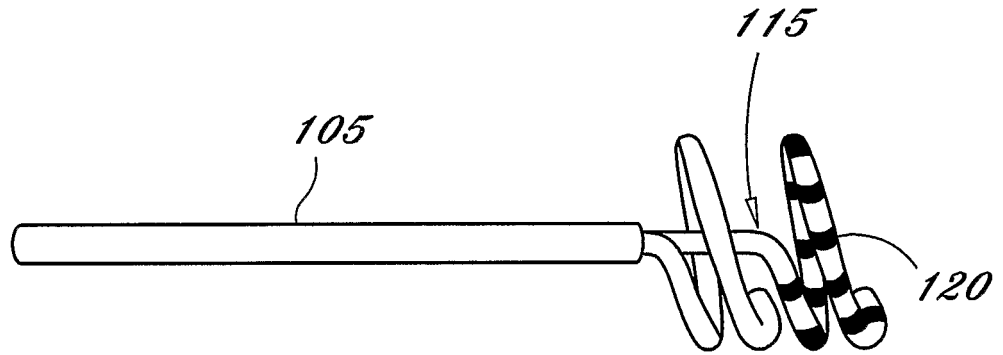

FIG. 4

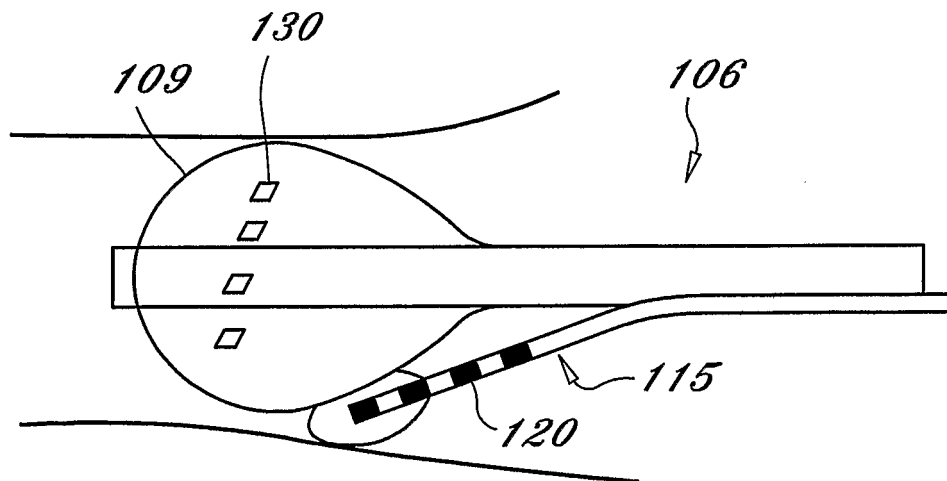

FIG. 5

INTERNATIONAL SEARCH REPORT

International application No
PCT/US2005/045989

A. CLASSIFICATION OF SUBJECT MATTER
A61B18/00 A61M25/09

According to International Patent Classification (IPC) or to both national classification and IPC

B. FIELDS SEARCHED
Minimum documentation searched (classification system followed by classification symbols)
A61B A61M

Documentation searched other than minimum documentation to the extent that such documents are included in the fields searched

Electronic data base consulted during the international search (name of data base and, where practical, search terms used)
EPO-Internal

C. DOCUMENTS CONSIDERED TO BE RELEVANT

| Category* | Citation of document, with indication, where appropriate, of the relevant passages | Relevant to claim No. |
|-----------|--|--|
| X | WO 00/51683 A (ATRIONIX, INC) 8 September 2000 (2000-09-08) cited in the application page 17, line 25 - page 61, line 13; figures 2B,26B-C,28H,31-33,35 ----- -/-- | 1-7, 9-24, 30-35, 37-39, 41-45, 51-57, 59-63, 69-71, 73-76 |

Further documents are listed in the continuation of Box C. See patent family annex.

* Special categories of cited documents :

"A" document defining the general state of the art which is not considered to be of particular relevance

"E" earlier document but published on or after the international filing date

"L" document which may throw doubts on priority claim(s) or which is cited to establish the publication date of another citation or other special reason (as specified)

"O" document referring to an oral disclosure, use, exhibition or other means

"P" document published prior to the international filing date but later than the priority date claimed

"T" later document published after the international filing date or priority date and not in conflict with the application but cited to understand the principle or theory underlying the invention

"X" document of particular relevance; the claimed invention cannot be considered novel or cannot be considered to involve an inventive step when the document is taken alone

"Y" document of particular relevance; the claimed invention cannot be considered to involve an inventive step when the document is combined with one or more other such documents, such combination being obvious to a person skilled in the art.

"&" document member of the same patent family

| | |
|---|--|
| Date of the actual completion of the international search 3 April 2006 | Date of mailing of the international search report 25/04/2006 |
|---|--|

| | |
|---|--------------------------------------|
| Name and mailing address of the ISA/ European Patent Office, P.B. 5818 Patentlaan 2 NL - 2280 HV Rijswijk Tel. (+31-70) 340-2040, Tx. 31 651 epo nl, Fax: (+31-70) 340-3016 | Authorized officer Artikis, T |
|---|--------------------------------------|

INTERNATIONAL SEARCH REPORT

International application No

PCT/US2005/045989

C(Continuation). DOCUMENTS CONSIDERED TO BE RELEVANT

| Category* | Citation of document, with indication, where appropriate, of the relevant passages | Relevant to claim No. |
|-----------|--|---|
| X | WO 2004/100813 A (MEDTRONIC, INC; STEWART, MARK, T; FIEDLER, GARY, R; SANDSTONE, JEFFREY) 25 November 2004 (2004-11-25) page 13, line 21 - page 46, line 27; figures 1A,3A,4 | 1-4,6,7, 10-16, 18-33, 35, 37-55, 57, 59-69, 71,73-76 |
| X | US 6 280 441 B1 (RYAN THOMAS PATRICK) 28 August 2001 (2001-08-28) column 5, line 49 - column 8, line 63; claims 1,7,33; figures 1,2,6-9 | 1-5,7,8, 10, 12-16, 18-25, 32,33, 36-39, 41-46, 51,52, 54, 57-64, 71-73, 75,76 |
| X | US 2003/088240 A1 (SAADAT VAHID) 8 May 2003 (2003-05-08) | 1-5,10, 12-14, 16-21, 23-25, 30,33, 60-64,71 |
| Y | paragraph [0043] - paragraph [0049] paragraph [0064] - paragraph [0070] figures 1,2,9,10A-C,13,15A-B | 22,36,75 |
| X | US 2004/059235 A1 (SAADAT VAHID) 25 March 2004 (2004-03-25) | 1,7,8, 10,11, 60-64, 71-73 |
| Y | paragraph [0025] - paragraph [0049]; figures 5,7,8,10 | 22,36,75 |

INTERNATIONAL SEARCH REPORT

Information on patent family members

International application No
PCT/US2005/045989

| Patent document cited in search report | Publication date | Patent family member(s) | Publication date |
|--|------------------|-------------------------|----------------------------|
| WO 0051683 | A | 08-09-2000 | AU 760660 B2 22-05-2003 |
| | | | AU 3863100 A 21-09-2000 |
| | | | CA 2364042 A1 08-09-2000 |
| | | | EP 1159036 A1 05-12-2001 |
| | | | JP 2002537913 A 12-11-2002 |
| | | | |
| WO 2004100813 | A | 25-11-2004 | NONE |
| | | | |
| US 6280441 | B1 | 28-08-2001 | NONE |
| | | | |
| US 2003088240 | A1 | 08-05-2003 | WO 03039338 A2 15-05-2003 |
| | | | |
| US 2004059235 | A1 | 25-03-2004 | NONE |
| | | | |

| | | | |
|----------------|---|---------|------------|
| 专利名称(译) | 组织消融系统包括具有传感元件的导丝 | | |
| 公开(公告)号 | EP1833395A1 | 公开(公告)日 | 2007-09-19 |
| 申请号 | EP2005854661 | 申请日 | 2005-12-16 |
| [标]申请(专利权)人(译) | CryoCath公司TECH | | |
| 申请(专利权)人(译) | CryoCath公司科技股份有限公司. | | |
| 当前申请(专利权)人(译) | MEDTRONIC CryoCath公司LP | | |
| [标]发明人 | LANE MIRIAM KANIA WLODZIMIERZ CARROLL SEAN SKANES ALLAN DR | | |
| 发明人 | LANE, MIRIAM KANIA, WLODZIMIERZ CARROLL, SEAN SKANES, ALLAN, DR. | | |
| IPC分类号 | A61B18/00 A61M25/09 A61B5/00 A61B17/00 A61B18/02 A61B18/04 A61B18/14 A61B18/18 | | |
| CPC分类号 | A61B5/6851 A61B5/6856 A61B18/02 A61B18/04 A61B18/1492 A61B18/18 A61B2017/00026 A61B2017/00044 A61B2017/00084 A61B2017/00243 A61B2017/00292 A61B2017/00867 A61B2018/00214 A61B2018/0212 A61B2018/1407 | | |
| 优先权 | 11/021113 2004-12-22 US | | |
| 外部链接 | Espacenet | | |

摘要(译)

一种用于消融人体组织的组织消融系统，其中独立地执行和控制感测和消融过程。传感线位于消融区域的远侧，并且适于穿过消融装置，使得其可以与消融装置一起移动或独立于消融装置移动，而不会阻塞消融能量的表面组织界面。消融装置可以消融组织的圆周区域的大部分，例如在肺静脉从心房延伸的位置处或附近。组织消融系统包括消融装置，该消融装置包括细长导管，该细长导管具有近端区域和远端区域以及位于导管远端区域附近的消融元件。一种具有细长主体的传感装置，所述细长主体具有近端部分和远端部分，所述传感装置适于定位在血管口处或其附近的血管内，其中所述传感装置适于可滑动地容纳在所述消融装置的内腔中。传感装置（例如，导丝）可以成形为各种构造，以允许诸如设置在其上的电极之类的传感装置接触消融区域附近的血管壁。以这种方式，感测和消融过程被解耦，使得感测装置不会干扰或阻碍消融构件与组织的界面