



(11) **EP 3 578 096 A1**

(12) **EUROPEAN PATENT APPLICATION**

(43) Date of publication:  
**11.12.2019 Bulletin 2019/50**

(51) Int Cl.:  
**A61B 5/00 (2006.01)**

(21) Application number: **18176595.9**

(22) Date of filing: **07.06.2018**

(84) Designated Contracting States:  
**AL AT BE BG CH CY CZ DE DK EE ES FI FR GB GR HR HU IE IS IT LI LT LU LV MC MK MT NL NO PL PT RO RS SE SI SK SM TR**  
Designated Extension States:  
**BA ME**  
Designated Validation States:  
**KH MA MD TN**

- **TASAR, Ozgur**  
**5656 AE Eindhoven (NL)**
- **TALGORN, Elise Claude Valentine**  
**5656 AE Eindhoven (NL)**
- **ADRIAENSSEN, Lieven**  
**5656 AE Eindhoven (NL)**
- **BARINK, Marco**  
**5656 AE Eindhoven (NL)**
- **SMITS, Edsger Constant Pieter**  
**5656 AE Eindhoven (NL)**
- **VAN DEN BRAND, Jeroen**  
**5656 AE Eindhoven (NL)**

(71) Applicants:

- **Koninklijke Philips N.V.**  
**5656 AE Eindhoven (NL)**
- **Nederlandse Organisatie voor toegepast-natuurwetenschappelijk onderzoek TNO**  
**2595 DA 's-Gravenhage (NL)**

(74) Representative: **de Haan, Poul Erik et al**  
**Philips International B.V.**  
**Philips Intellectual Property & Standards**  
**High Tech Campus 5**  
**5656 AE Eindhoven (NL)**

(72) Inventors:

- **GROB, Timon Rutger**  
**5656 AE Eindhoven (NL)**

(54) **A WEARABLE DEVICE**

(57) A wearable system is for mounting against the skin of a subject. It comprises a flexible circuit board (20) sandwiched (e.g. laminated) between a top layer (30) and a base layer (12). The flexible circuit board has a meander section (26) between end pads (22, 24). The base layer and the top layer are bonded together by a bonding layer (40) which has a meander opening (42) around the meander section. This means the stretchability of the meander section is not inhibited by the lamination process.

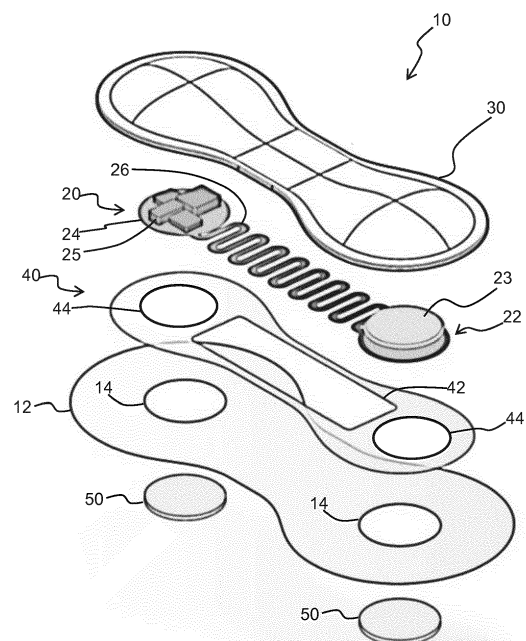

FIG. 3

## Description

### FIELD OF THE INVENTION

**[0001]** This invention relates to wearable devices such as actuators or sensors. For example, the invention is of interest for sensors for measuring one or more physiological parameters of a subject, wherein the sensor can be worn by the subject. For example, the invention relates to a wearable patch which may implement a photoplethysmographic (PPG) sensor, an electrocardiogram (ECG) sensor, an electroencephalogram sensor (EEG), a wearable ultrasound sensor (US), a wearable heart rate sensor, a wearable galvanic skin response sensor (GSR) or a motion sensor.

### BACKGROUND OF THE INVENTION

**[0002]** Monitoring of physiological parameters is of increasing interest, to allow for better diagnosis and patient monitoring. It is for example known to provide wearable monitoring devices, such as patches, that subjects can wear in low acuity settings such as the general ward and at home. Better monitoring in general wards is needed to reduce the mortality rate. Also, accountable care drives the need to discharge patients to their home, and continue a level of monitoring at home for a period of time, typically up to 30 days.

**[0003]** In general, patch comfort is very important, especially in the home monitoring context where it will influence patient adherence. In addition to comfort, reliability of a wearable sensor is important in order to reach the desired period (e.g. 30 days) of home monitoring.

**[0004]** Wearable devices are convenient to use as they offer increased freedom of movement for the user whilst a physiological parameter is being monitored. In this way, it is possible to measure physiological parameters in a variety of circumstances, for example at different levels of physical exertion of the subject.

**[0005]** The physiological parameter sensor may be mounted to the user differently in different applications. The position of the mounted physiological parameter sensor relative to the subject depends on the type of physiological parameter sensor, and/or the circumstances in which physiological sensing takes place. In general, the physiological parameter sensor should be in contact with the skin but there are other cases in which a physiological parameter sensor should be separated from the subject's body.

**[0006]** For instance, in PPG monitoring, a steady distance between a light sensor and the skin is desired for optimal stability of the sensor signal. For ultrasound transducer patches, good contact with the skin is imperative for high quality images. Similarly, the electrodes of ECG monitoring devices or GSR sensors should be in contact with the skin.

**[0007]** Many sensor designs make use of multiple sensing locations of the skin, for example so that electri-

cal conductivity can be measured between those points, or so that different signal timings at different locations can be determined. A sensor system which employs multiple different sensing modalities may also have multiple sensing locations.

**[0008]** This invention relates in particular to wearable systems which make use of contact locations for sensing or actuation. The multiple locations may for example relate to monitoring of a single physiological parameter, or multiple parameters. There is a need to enable these multiple sensor or actuation locations to move relative to each other, so that the body to which they are attached is able to move, for example due to breathing, the heart pulse, or just general body movement of the subject wearing the sensor system.

**[0009]** Generally, these different locations need to be able to communicate electrically with each other, for example so that a single processing site can gather sensing data from the multiple areas. This requires connecting conductive tracks between the contact locations. It is known to provide these connecting conductive tracks as meander paths, to provide a degree of stretchability. Flexibility and stretchability are key for comfort and for good skin contact.

**[0010]** A flexible printed circuit board (PCB) including a meander interconnect may for example be provided. Specific meander shapes can be used to minimize the force needed to stretch in 3D while minimizing the stress at critical points, hence minimizing chances of cracking or breaking.

**[0011]** The PCB may for example be encapsulated in an outer housing, together with the sensor circuitry, to form a sensor patch.

**[0012]** It is known for example for the PCB to be encapsulated. However, a preferred manufacturing process is a lamination process. Laminated sensor patches are for example built of layers manufactured mainly by a reel-to-reel process.

**[0013]** However, the reliability of the interconnect provided by the meandering PCB reduces when the meanders are more constrained by lamination. In particular stretching capability provided by the meandering section is limited. There is therefore a need for an improved design for a wearable device, such as for use as a wearable sensor patch.

### SUMMARY OF THE INVENTION

**[0014]** The invention is defined by the claims.

**[0015]** According to examples in accordance with an aspect of the invention, there is provided a wearable system for mounting against the skin of a subject, comprising:

a base layer;  
a flexible circuit board comprising:

a first end pad having a first contact area facing

the base layer;  
 a second end pad having a second contact area facing the base layer; and  
 a flexible meander section between the first and second end pads; and a top layer, wherein the flexible circuit board is sandwiched between the base layer and the top layer,

wherein the base layer and the top layer are bonded together by a bonding layer which has a meander opening around the flexible meander section.

**[0016]** This system has two (or more) pads for contacting the skin of a subject or for positioning in close proximity to the skin of the subject, for example for taking readings of one or more physiological parameters, in particular which (either individually or together) require two or more contact points. It may instead be for providing signals to the skin. The two pads are connected by a meander section which gives stretchability to the system, so that it can adapt to the shape of the subject, which may also evolve as the subject moves. The meander section is in a non-bonded region so that the out of plane flexing of the meander section is not inhibited by coupling to the top layer and/or to the base layer. The deformation is thus not enforced by and/or constrained by the top and/or the base layer.

**[0017]** This arrangement gives increased freedom of deformation of the meander section, and this increases the reliability of the interconnection significantly. A completely free-standing interconnect gives usability issues, for example the interconnect may be damaged due to snagging behind something, e.g. clothing. Thus, the invention provides encapsulation (e.g. by lamination) between the top and base layers, but without adhesion in the region of the meander section.

**[0018]** The base layer may comprise first and second base layer openings beneath the first and second contact areas. These enable direct access to the pad contact areas. This is of interest if direct galvanic contact is desired with the skin. This depends on the type of sensor or actuator. For example, indirect contact may be sufficient for a capacitive sensor or movement sensor, whereas direct contact may be desired for a skin resistance sensor or ECG sensor.

**[0019]** The system may then comprise a first skin contact electrode and a second skin contact electrode in the first and second openings, which connect to the first and second contact areas. These may project out of the plane of the base layer to provide protruding contact electrodes. The first and second skin contact electrodes for example comprise gel electrodes.

**[0020]** The bonding layer may also comprise first and second bonding layer openings corresponding to the first and second base layer openings. When the bonding layer is beneath the flexible circuit board (i.e. between the circuit board and the base layer), these openings again allow direct contact with the contact areas of the end pads.

However, the bonding layer may instead be above the circuit board (i.e. between the circuit board and the top layer) in which case the openings are not required.

**[0021]** The bonding layer may comprise contact anchors within the meander opening. These may for example make connections in the meander spaces, so that they increase the overall structural unity of the system but without constraining movement of the meander section.

**[0022]** The first end pad may have a first circuit area on the opposite side to the first contact area, and the second end pad may have a second circuit area on the opposite side to the second contact area.

**[0023]** A battery may be provided on the first circuit area and a signal processing circuit may be provided on the second circuit area. One of the first and/or second circuit areas may for example comprise a wireless communications circuit. Thus, the required circuit components may be shared between the available areas. The electrical functions for example include local battery power, local memory storage, wireless signal transmission (and optionally also signal reception, for example for receiving a command to perform sensing, or to download stored sensor data), and optionally sensor signal processing. One of the first and second circuit areas may also comprise a display device to enable sensor information to be read out directly instead of, or as well as, being stored and/or communicated to an external device.

**[0024]** The meander section preferably carries only interconnect tracks. In particular, the flexible meander section preferably comprises an electrical connection between the first and second end pads.

**[0025]** The bonding layer may comprise a hot-melt layer, a pressure sensitive adhesive, a UV-curable adhesive or a double sided adhesive tape. It is for example used to connect the top and base layers as part of a thermal lamination process.

**[0026]** The device preferably comprises a wearable sensor patch. There may be three or more end pads, interconnected by two or more flexible meander sections.

**[0027]** The sensor system for example comprises one (or more) from the list of:

- an ECG sensor;
- a PPG sensor;
- an EEG sensor;
- a GSR sensor;
- a thermistor temperature sensor;
- an accelerometer.

**[0028]** These and other aspects of the invention will be apparent from and elucidated with reference to the embodiment(s) described hereinafter.

## BRIEF DESCRIPTION OF THE DRAWINGS

**[0029]** For a better understanding of the invention, and to show more clearly how it may be carried into effect,

reference will now be made, by way of example only, to the accompanying drawings, in which:

Fig. 1 shows a known sensor patch;

Fig. 2 shows in simplified form the design of the bonding layer used for a sensor patch in accordance with one example of the invention;

Fig. 3 shows an example of sensor system, in exploded view;

Fig. 4 shows a variation to the design of the bonding layer; and

Fig. 5 shows a modification to the design of the bonding layer of Fig. 4.

#### DETAILED DESCRIPTION OF THE EMBODIMENTS

**[0030]** The invention will be described with reference to the Figures.

**[0031]** It should be understood that the detailed description and specific examples, while indicating exemplary embodiments of the apparatus, systems and methods, are intended for purposes of illustration only and are not intended to limit the scope of the invention. These and other features, aspects, and advantages of the apparatus, systems and methods of the present invention will become better understood from the following description, appended claims, and accompanying drawings. It should be understood that the Figures are merely schematic and are not drawn to scale. It should also be understood that the same reference numerals are used throughout the Figures to indicate the same or similar parts.

**[0032]** The invention provides a wearable system such as a sensor system for mounting against the skin of a subject. It comprises a flexible circuit board sandwiched (e.g. laminated) between a top layer and a base layer. The flexible circuit board has a meander section between end pads. The base layer and the top layer are bonded together by a bonding layer which has a meander opening around the meander section. This means the stretchability of the meander section is not inhibited by the lamination process.

**[0033]** Fig. 1 shows a known sensor patch 10, comprising a base layer 12, a flexible circuit board 20 and a top layer 30. The flexible circuit board 20 has two end pads 22, 24 which are interconnected by a meander section 26.

**[0034]** The three layers shown are laminated together to form a sealed patch.

**[0035]** Fig. 2 shows in simplified form a design of the bonding layer used in the lamination process for a sensor system in accordance with an example of the invention. In this example, the bonding layer 40 is to be provided over the flexible circuit board. The bonding layer 40 has an opening 42 over the meander section 26 so that the meander section is not constrained by the lamination process. Fig. 2 shows the meander section 26 beneath the bonding layer, seen through the opening 42, for clar-

ity.

**[0036]** Fig. 3 shows an example of wearable system, in exploded view.

**[0037]** The wearable system comprises a base layer 12, a flexible circuit board 20, a top layer 30 and the bonding layer 40 with a meander opening 42. In this example, the bonding layer is beneath the flexible circuit board, namely between the flexible circuit board and the base layer. Bonding can additionally or alternatively be provided between the top layer and the flexible circuit board, again excluding the meander section. Thus, the bonding may be provided above and/or below the flexible circuit board.

**[0038]** The flexible circuit board 20 comprises a first end pad 22 having a first contact area facing the base layer (and hence not seen in Fig. 4). The opposite side of the first contact area may in one example comprise a first circuit area, which for example provides connections to a battery 23.

**[0039]** A second end pad 24 has a second contact area facing the base layer (again not seen in Fig. 3). The opposite side of the second contact area may in one example comprise a second circuit area, which for example provides connections to sensor processing circuitry and wireless transmission circuitry 25.

**[0040]** This flexible circuit board may comprise a conventional polyimide flexible PCB, but it may also comprise screen-printed or inkjet-printed circuitry on a bendable polymer substrate such as polyethylene naphthalate (PEN) or polyethylene terephthalate (PET).

**[0041]** The meander section 26 is between the first and second end pads and it provides electrical connections between the circuitry carried by the end pads, as well as providing connections to and the contact areas of the end pads. The meander section preferably carries only interconnect tracks. In particular, the meander section preferably comprises an electrical connection between the first and second end pads.

**[0042]** The flexible circuit board is for example a double-sided board, with contact areas facing the base layer which function as sensor input pads or actuator output pads, and electrical tracks facing the top layer which function as connection lines and contact pads for circuit components.

**[0043]** In the example shown in Fig. 3, the contact areas on the underside of the end pads are for making direct galvanic contact with the skin. The base layer 12 has openings 14 aligned with the contact areas, and the bonding layer 40 also has corresponding openings 44.

**[0044]** To provide an interface between the skin and the contact areas, gel contact electrodes 50 can be provided. These fit in the openings 14 and 44 so that skin contact pads extend beyond the plane of the base layer 12.

**[0045]** The most basic design has two pads for contacting the skin of the subject, but there may be three or more pads, interconnected with each other by meander sections. The meander section is in a non-bonded region

so that the stretching of the meander section is not inhibited by coupling to the top layer or base layer. In this way, there is increased freedom of deformation of the meander section.

**[0046]** The meander section is preferably planar and defines an undulating track in that plane, for example a sequence of alternate U-bends as shown. However, other meandering paths may be formed, for example which overall follow a straight path or a curved path.

**[0047]** The bonding layer may simply be around the outer edge of the overall wearable system outer housing, so that that openings 42, 44 are formed as a single opening.

**[0048]** However, the bonding layer preferably surrounds or covers (from above or below) the end pads so that each end pad is formed into its own enclosure. Thus, in the example of Fig. 3, there is a region of the bonding layer fully around each opening 44, and in the example of Fig. 2 the bonding layer fully covers each end pad. This provides better sealing for the circuit components.

**[0049]** The meander opening may be a rectangle corresponding to the outer envelope shape of the meander section. However, other shapes may be used. The meander opening may fully surround the meander section 26 but there may be portions of the meander section which are covered by the bonding layer, such as the ends.

**[0050]** Fig. 4 shows a variation to the design of the bonding layer 40. The end pads are each formed as a double circle to enable increased contact area. The circuitry may for example all be on one side of the flexible circuit board, facing downwardly. A central area 60 provides a connection to a non-flex printed circuit board.

**[0051]** The meander opening 42 is formed as two sections 42a, 42b, one on each side of the central area 60.

**[0052]** Fig. 5 shows a modification to the design of the bonding layer of Fig. 4. The bonding layer 40 has contact anchors 70 within the meander openings 42a, 42b. These make connections between the top layer and base layer in the spaces between the meandering path of the circuit board. The overall structural unity of the system is improved but without constraining movement of the meander section.

**[0053]** The bonding layer may be a hot-melt layer for thermal curing during lamination, such as a polyurethane film, or another adhesive for example using a silicone adhesive, a polyurethane adhesive or an acrylic adhesive. Adhesive foams may also be used.

**[0054]** The top layer 30 is for example a foam structure, such as a thermoform foam structure. It has a shape to provide housing areas for the circuit components.

**[0055]** The flexible circuit board 20 is for example a polyimide flexible foil (e.g. with thickness of tens of microns) with a copper conductor layer (e.g. also with thickness of ones or tens of microns).

**[0056]** The base layer 12 comprises a liner of silicone or thermoplastic polyurethane.

**[0057]** The contact electrodes 50 for example comprise screen printed silver chloride which are provided at

the contact areas (at the bottom of the flexible circuit board). Contact electrodes may alternatively be provided using conductive adhesive.

**[0058]** The wearable system for example comprises one (or more) sensor types from the list of:

- an ECG sensor;
- a PPG sensor;
- an EEG sensor;
- a GSR sensor;
- a thermistor temperature sensor;
- an accelerometer.

**[0059]** The wearable system may thus be used to determine one or more of various parameters such as heart rate, respiratory rate, heart rate variability, skin temperature, body posture, fall detection and activity level (such as a steps count).

**[0060]** As mentioned above, the wearable system is preferably battery operated, and a battery is provided on one of the circuit areas. A signal conditioning or processing circuit and wireless communications circuit are also provided on the circuit areas. There may also be memory storage, a display device.

**[0061]** The invention applies to wearable sensors or actuators, and they may take the form of a patch or a textile.

**[0062]** The invention is not limited to physiological sensory body systems. It can also be used for example for body motion sensing. In that case the wearable sensors will not measure a physiological body parameter, but will be in the form of a gyroscope or accelerometer which determines the movement of the body. Another option is non-sensory electronics in a shirt such as lights, stretchable displays, solar cells, heating, or even certain therapy options. The meander design can be used in all of these stretchable electronics cases.

**[0063]** Variations to the disclosed embodiments can be understood and effected by those skilled in the art in practicing the claimed invention, from a study of the drawings, the disclosure and the appended claims. In the claims, the word "comprising" does not exclude other elements or steps, and the indefinite article "a" or "an" does not exclude a plurality. A single processor or other unit may fulfill the functions of several items recited in the claims. The mere fact that certain measures are recited in mutually different dependent claims does not indicate that a combination of these measures cannot be used to advantage. A computer program may be stored/distributed on a suitable medium, such as an optical storage medium or a solid-state medium supplied together with or as part of other hardware, but may also be distributed in other forms, such as via the Internet or other wired or wireless telecommunication systems. Any reference signs in the claims should not be construed as limiting the scope.

**Claims**

1. A wearable system (10) for mounting against the skin of a subject, comprising:
- a base layer (12);
- a flexible circuit board (20) comprising:
- a first end pad (22) having a first contact area facing the base layer;
- a second end pad (24) having a second contact area facing the base layer; and
- a flexible meander section (26) between the first and second end pads; and
- a top layer (30), wherein the flexible circuit board is sandwiched between the base layer and the top layer, wherein the base layer (12) and the top layer (30) are bonded together by a bonding layer (40) which has a meander opening (42) around the flexible meander section.
2. A system as claimed in claim 1, wherein the base layer (12) comprise first and second base layer openings (14) beneath the first and second contact areas.
3. A system as claimed in claim 2, further comprising first and second skin contact electrodes (50) in the first and second base layer openings (14), which connect to the first and second contact areas.
4. A system as claimed in claim 3, wherein the first and second skin contact electrodes (50) comprise gel electrodes.
5. A system as claimed in any one of claims 1 to 4, wherein the bonding layer (40) comprises first and second bonding layer openings (44) corresponding to the first and second base layer openings (14).
6. A system as claimed in any one of claims 1 to 5, wherein the bonding layer (40) comprises contact anchors (70) within the meander opening (42).
7. A system as claimed in any one of claims 1 to 6, wherein the first end pad (22) has a first circuit area on the opposite side to the first contact area and the second end pad (24) has a second circuit area on the opposite side to the second contact area.
8. A system as claimed in claim 7, comprising a battery (23) on the first circuit area.
9. A system as claimed in claim 7 or 8, comprising a signal processing circuit (25) on the second circuit area.
10. A system as claimed in any one of claims 7 to 9, wherein one of the first and second circuit areas comprises a wireless communications circuit and/or a display device.
11. A system as claimed in any one of claims 1 to 10, wherein the bonding layer (40) comprises a hot-melt layer, a pressure sensitive adhesive, a UV-curable adhesive or a double sided adhesive tape.
12. A system as claimed in any one of claims 1 to 11, wherein the flexible meander section (26) comprises an electrical connection between the first and second end pads (20, 22).
13. A system as claimed in any one of claims 1 to 12, comprising a wearable sensor patch.
14. A system as claimed in any one of claims 1 to 13, comprising a set of three or more end pads, interconnected by two or more flexible meander sections.
15. A system as claimed in any one of claims 1 to 14, comprising one or more from the list of:
- an ECG sensor;
- a PPG sensor;
- an EEG sensor;
- a GSR sensor;
- a thermistor temperature sensor;
- an accelerometer.

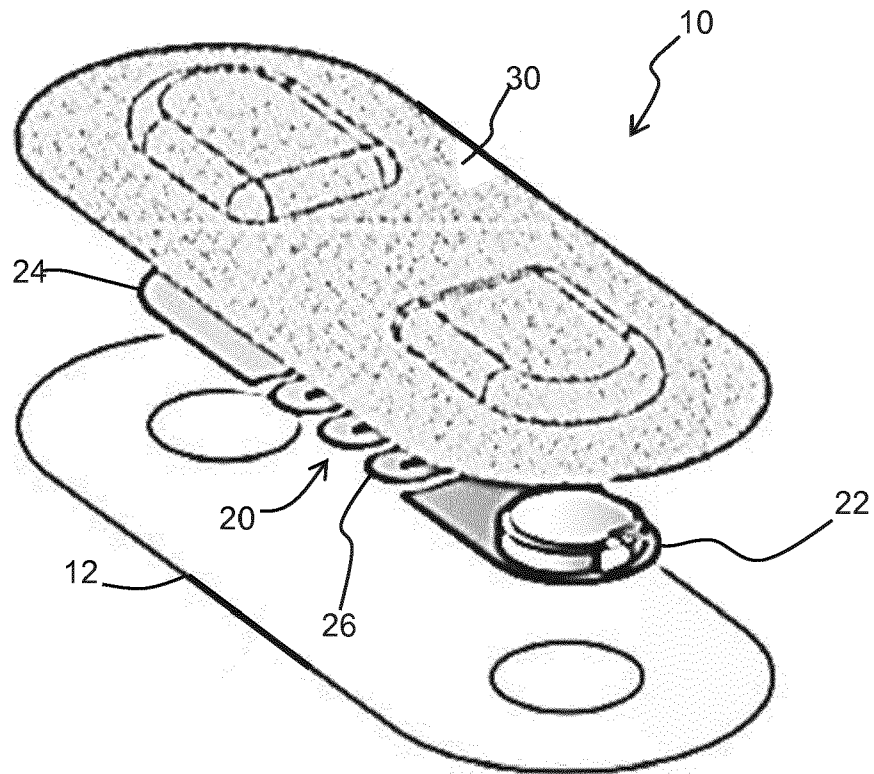

FIG. 1

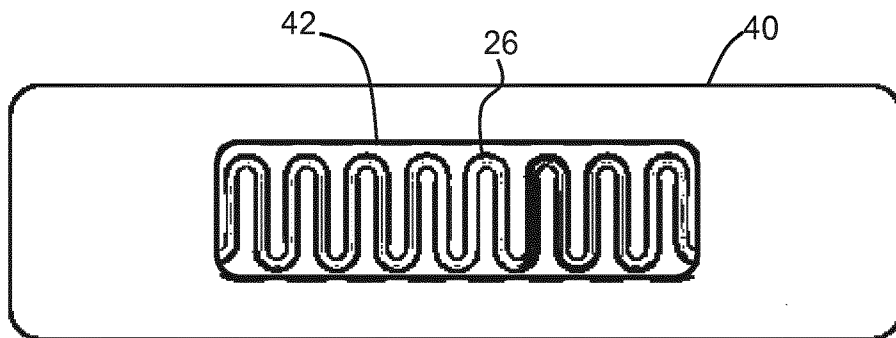

FIG. 2

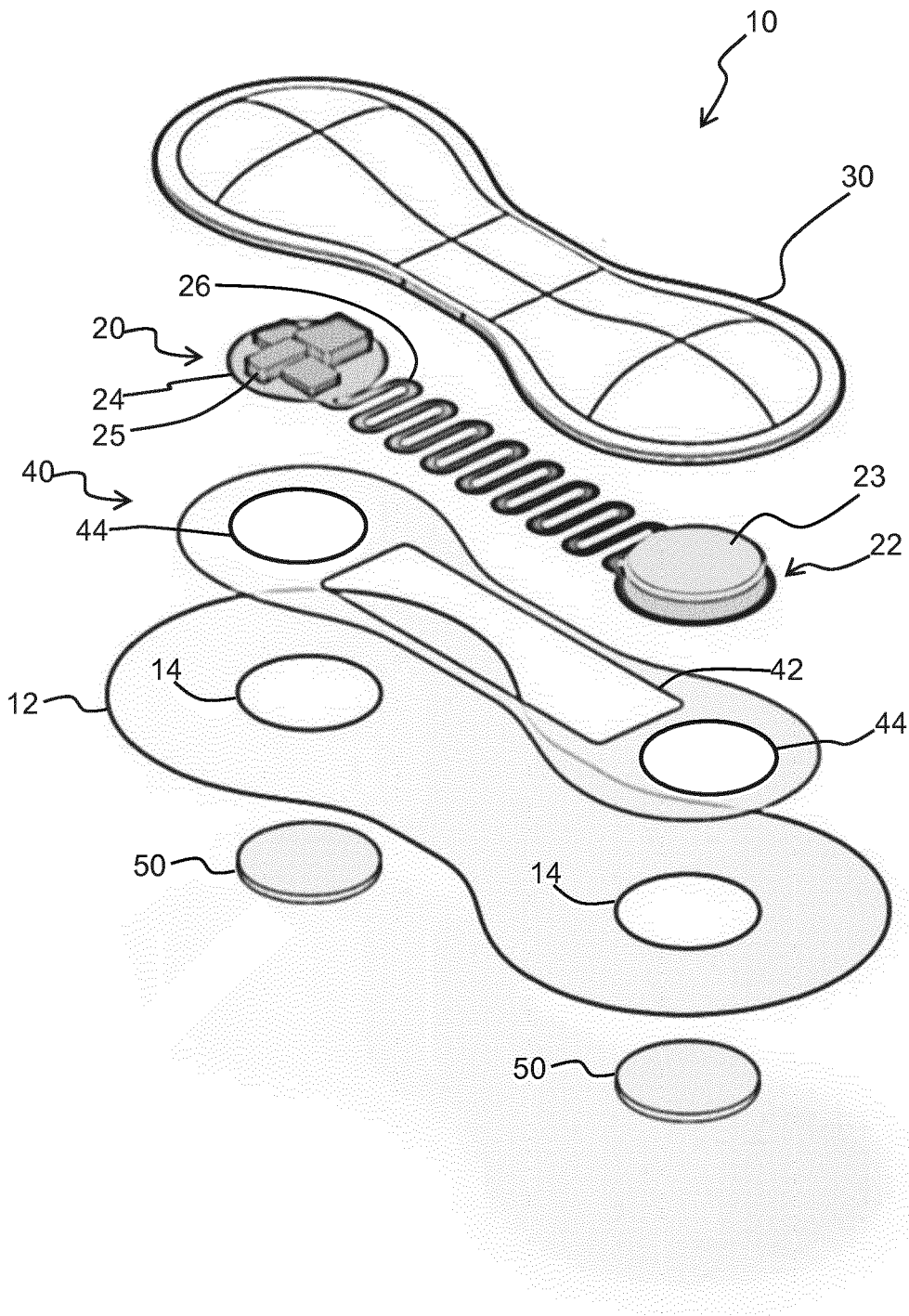

FIG. 3

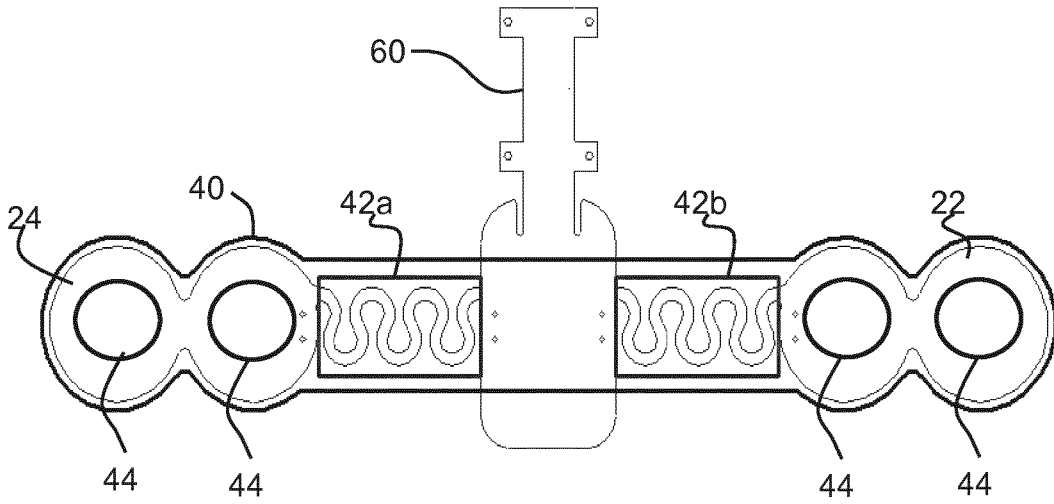

FIG. 4

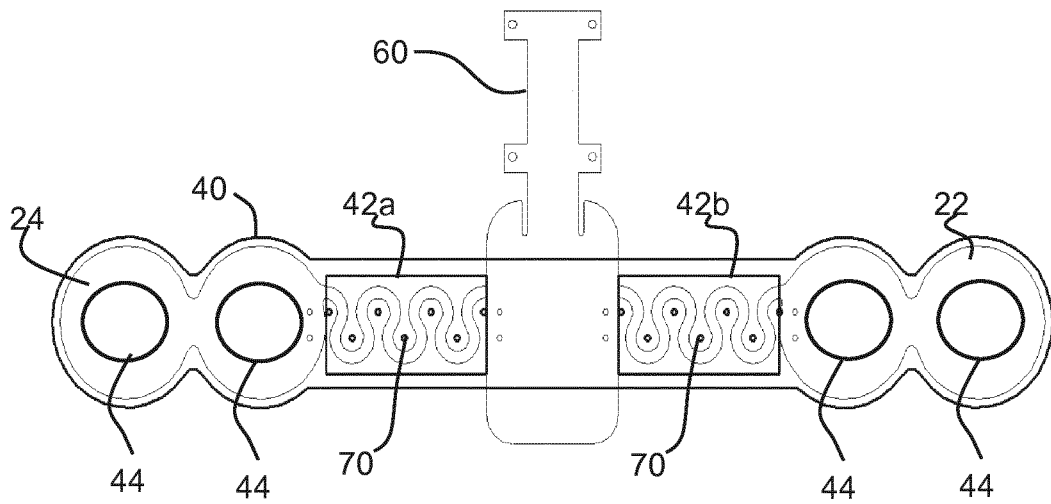

FIG. 5



EUROPEAN SEARCH REPORT

Application Number  
EP 18 17 6595

5

10

15

20

25

30

35

40

45

50

55

DOCUMENTS CONSIDERED TO BE RELEVANT			
Category	Citation of document with indication, where appropriate, of relevant passages	Relevant to claim	CLASSIFICATION OF THE APPLICATION (IPC)
X	WEI PINGHUNG ET AL: "A stretchable and flexible system for skin-mounted measurement of motion tracking and physiological signals", 2014 36TH ANNUAL INTERNATIONAL CONFERENCE OF THE IEEE ENGINEERING IN MEDICINE AND BIOLOGY SOCIETY, IEEE, 26 August 2014 (2014-08-26), pages 5772-5775, XP032674410, DOI: 10.1109/EMBC.2014.6944939 [retrieved on 2014-11-02] * page 5772, column 2 - page 5773, column 1; figures 1,3 * * page 5774, column 2, line 7 *	1-15	INV. A61B5/00
A	RAJ M ET AL: "Soft bio-integrated systems for continuous health monitoring", VISUAL COMMUNICATIONS AND IMAGE PROCESSING; 20-1-2004 - 20-1-2004; SAN JOSE,, vol. 9083, 4 June 2014 (2014-06-04), pages 90831M-90831M, XP060037124, DOI: 10.1117/12.2051272 ISBN: 978-1-62841-730-2 * figure 4 *	1,14	TECHNICAL FIELDS SEARCHED (IPC) A61B
A	TRIPATHI RAGHUVENDRA PRATAP ET AL: "Design and fabrication of a nano patch electrode for ECG using CNT/PDMS", 2017 INTERNATIONAL CONFERENCE ON COMPUTING METHODOLOGIES AND COMMUNICATION (ICCMC), IEEE, 18 July 2017 (2017-07-18), pages 335-339, XP033315341, DOI: 10.1109/ICCMC.2017.8282703 [retrieved on 2018-02-05] * figure 5 *	1	
The present search report has been drawn up for all claims			
Place of search The Hague		Date of completion of the search 30 November 2018	Examiner Pameijer, Robert
CATEGORY OF CITED DOCUMENTS X : particularly relevant if taken alone Y : particularly relevant if combined with another document of the same category A : technological background O : non-written disclosure P : intermediate document		T : theory or principle underlying the invention E : earlier patent document, but published on, or after the filing date D : document cited in the application L : document cited for other reasons & : member of the same patent family, corresponding document	

EPO FORM 1503 03.82 (P04C01)



EUROPEAN SEARCH REPORT

Application Number  
EP 18 17 6595

5

10

15

20

25

30

35

40

45

50

55

DOCUMENTS CONSIDERED TO BE RELEVANT			
Category	Citation of document with indication, where appropriate, of relevant passages	Relevant to claim	CLASSIFICATION OF THE APPLICATION (IPC)
A	SEULKI LEE ET AL: "The Smart Patches and Wearable Band (W-Band) for comfortable sleep monitoring system", ENGINEERING IN MEDICINE AND BIOLOGY SOCIETY,EMBC, 2011 ANNUAL INTERNATIONAL CONFERENCE OF THE IEEE, IEEE, 30 August 2011 (2011-08-30), pages 6915-6918, XP032320308, DOI: 10.1109/IEEMBS.2011.6091741 ISBN: 978-1-4244-4121-1 * figures 2, 3, 4, 6, *	1	TECHNICAL FIELDS SEARCHED (IPC)
A	VAN DEN BRAND JEROEN ET AL: "Flexible and stretchable electronics for wearable healthcare", 2014 44TH EUROPEAN SOLID STATE DEVICE RESEARCH CONFERENCE (ESSDERC), IEEE, 22 September 2014 (2014-09-22), pages 206-209, XP032677149, ISSN: 1930-8876, DOI: 10.1109/ESSDERC.2014.6948796 ISBN: 978-1-4799-4378-4 [retrieved on 2014-11-05] * figures 1, 2, 5 *	1	
A	US 2018/028071 A1 (SHI WEI [US]) 1 February 2018 (2018-02-01) * paragraph [0041]; figure 4 *	1	
The present search report has been drawn up for all claims			
Place of search The Hague		Date of completion of the search 30 November 2018	Examiner Pameijer, Robert
CATEGORY OF CITED DOCUMENTS X : particularly relevant if taken alone Y : particularly relevant if combined with another document of the same category A : technological background O : non-written disclosure P : intermediate document		T : theory or principle underlying the invention E : earlier patent document, but published on, or after the filing date D : document cited in the application L : document cited for other reasons & : member of the same patent family, corresponding document	

EPO FORM 1503 03.82 (P04C01)

**ANNEX TO THE EUROPEAN SEARCH REPORT  
ON EUROPEAN PATENT APPLICATION NO.**

EP 18 17 6595

5 This annex lists the patent family members relating to the patent documents cited in the above-mentioned European search report.  
The members are as contained in the European Patent Office EDP file on  
The European Patent Office is in no way liable for these particulars which are merely given for the purpose of information.

30-11-2018

10  
15  
20  
25  
30  
35  
40  
45  
50  
55

Patent document cited in search report	Publication date	Patent family member(s)	Publication date
US 2018028071 A1	01-02-2018	NONE	
-----			

EPO FORM P0459

For more details about this annex : see Official Journal of the European Patent Office, No. 12/82

专利名称(译)	可穿戴设备		
公开(公告)号	<a href="#">EP3578096A1</a>	公开(公告)日	2019-12-11
申请号	EP2018176595	申请日	2018-06-07
[标]申请(专利权)人(译)	皇家飞利浦电子股份有限公司 荷兰应用自然科学研究组织		
申请(专利权)人(译)	皇家飞利浦N.V. NEDERLANDSE ORGANISATIE VOOR TOEGEPAST- NATUURWETENSCHAPPELIJK ONDERZOEK TNO		
当前申请(专利权)人(译)	皇家飞利浦N.V. NEDERLANDSE ORGANISATIE VOOR TOEGEPAST- NATUURWETENSCHAPPELIJK ONDERZOEK TNO		
[标]发明人	GROB TIMON RUTGER TASAR OZGUR TALGORN ELISE CLAUDE VALENTINE ADRIAENSSEN LIEVEN BARINK MARCO SMITS EDSGER CONSTANT PIETER VAN DEN BRAND JEROEN		
发明人	GROB, TIMON RUTGER TASAR, OZGUR TALGORN, ELISE CLAUDE VALENTINE ADRIAENSSEN, LIEVEN BARINK, MARCO SMITS, EDSGER CONSTANT PIETER VAN DEN BRAND, JEROEN		
IPC分类号	A61B5/00		
CPC分类号	A61B5/6814 A61B5/6833		
代理机构(译)	德哈恩波尔ERIK		
外部链接	<a href="#">Espacenet</a>		

摘要(译)

可穿戴系统用于安装在对象的皮肤上。它包括夹在顶层(30)和底层(12)之间的柔性电路板(20)。柔性电路板在端板(22、24)之间具有弯曲部分(26)。基础层和顶层通过粘结层(40)粘结在一起,粘结层(40)在弯曲部分周围具有弯曲开口(42)。这意味着曲折段的可拉伸性不受层压过程的限制。

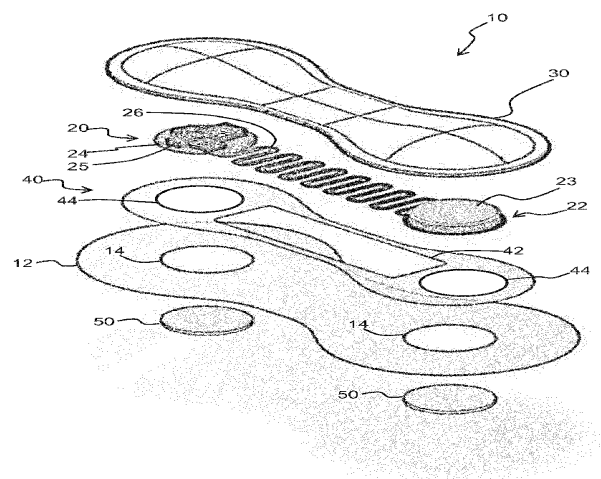

FIG. 3