



(12) **EUROPEAN PATENT APPLICATION**
 published in accordance with Art. 153(4) EPC

(43) Date of publication:
27.03.2019 Bulletin 2019/13

(21) Application number: **17799433.2**

(22) Date of filing: **17.05.2017**

(51) Int Cl.:
A61B 5/11 (2006.01) **A61B 5/00 (2006.01)**
A61B 5/0245 (2006.01) **A61B 5/08 (2006.01)**
A61B 5/113 (2006.01) **A61G 7/05 (2006.01)**
G08B 21/06 (2006.01) **G08B 21/22 (2006.01)**

(86) International application number:
PCT/JP2017/018542

(87) International publication number:
WO 2017/200009 (23.11.2017 Gazette 2017/47)

(84) Designated Contracting States:
AL AT BE BG CH CY CZ DE DK EE ES FI FR GB GR HR HU IE IS IT LI LT LU LV MC MK MT NL NO PL PT RO RS SE SI SK SM TR
 Designated Extension States:
BA ME
 Designated Validation States:
MA MD

(30) Priority: **20.05.2016 JP 2016101356**

(71) Applicant: **Minebea Mitsumi Inc.**
Kitasaku-gun, Nagano 389-0293 (JP)

(72) Inventors:
 • **AKATSU, Hiroyuki**
Kitasaku-gun
Nagano 389-0293 (JP)
 • **IIDA, Norihito**
Kitasaku-gun
Nagano 389-0293 (JP)

(74) Representative: **Liesegang, Eva**
Boehmert & Boehmert
Anwaltpartnerschaft mbB
Pettenkofenstrasse 22
80336 München (DE)

(54) **BIOLOGICAL INFORMATION MONITORING SYSTEM**

(57) A biological information monitoring system (100) for monitoring various biological information on a subject (S) on a bed (BD), the system including: a plurality of load detectors (11, 12, 13, 14) to be placed in the bed or under legs of the bed, each of the plurality of load detectors being configured to detect a load of the subject and output the detected load as a load signal; a signal sep-

aration unit (32) configured to separate components each corresponding to each of a plurality of frequency ranges, from the load signal outputted from each of the load detectors; and a center of gravity position calculation unit (33) configured to calculate a center of gravity position of the subject based on the separated components.

Fig. 1

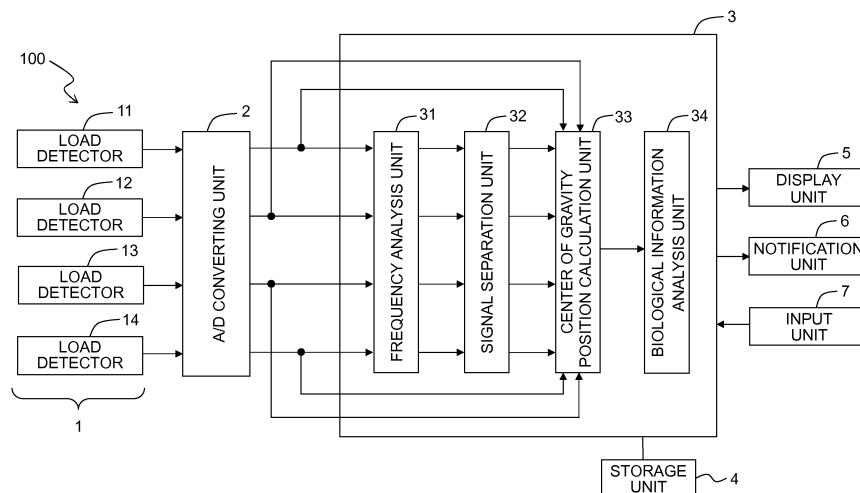

Description

TECHNICAL FIELD

5 [0001] The present invention relates to a biological information monitoring system for monitoring biological information of a subject (a human subject) on the basis of the variation of a center of gravity position of the subject on a bed.

BACKGROUND ART

10 [0002] Biological information of a subject is one of the important pieces of information for knowing the physical condition (body condition) of a patient or a care receiver in the sites of the medical treatment and the care. For example, the respiratory condition (respiratory state) of the subject is grasped and can be utilized to grasp the symptoms of, for example, the sleep apnea syndrome (SAS) and the snore; and to improve (alleviate) the symptoms.

15 [0003] It has been suggested that load sensors are arranged under legs of a bed to measure the respiratory condition of a subject on the basis of measured values of the load sensors (Patent Literature 1). Further, it has been also suggested that load detectors are arranged under legs of a bed to acquire (obtain) the movement of the center of gravity of a subject living body on the bed so that the respiratory movement (breathing movement) and the heartbeat movement of the subject living body are acquired on the basis of the movement of the center of gravity (Patent Literature 2).

20 **Citation List**

[0004]

Patent Literature 1: Japanese Patent No. 4883380

25 Patent Literature 2: Japanese Patent Publication No. 61-24010

SUMMARY

Technical Problem

30 [0005] In the sites of the medical treatment, it is desired to accurately grasp the center of gravity position of a subject on a bed; however, the inventions described in Patent Literatures 1 and 2 fail to meet such on-site demands.

[0006] An object of the present invention is to provide a biological information monitoring system which enables to further accurately grasp biological information, for example, a center of gravity position, of a subject on a bed.

35 **Solution to the Problem**

[0007] According to a first aspect of the present invention, there is provided a biological information monitoring system for monitoring biological information on subjects on a bed, the system including: a plurality of load detectors to be placed in the bed or under legs of the bed, each of the plurality of load detectors being configured to detect loads of the subjects and output the detected loads as a load signal; and a signal separation unit configured to determine a number of the subjects on the bed based on a frequency spectrum of the load signal outputted from each of the plurality of load detectors, and separate, with respect to each of the subjects, components each corresponding to each of a plurality of frequency ranges from the load signal outputted from each of the plurality of load detectors.

40 [0008] In the biological information monitoring system according to the first aspect, the signal separation unit may be configured to determine that the number of peak frequencies appeared in the frequency spectrum is the number of the subjects on the bed.

[0009] In the biological information monitoring system according to the first aspect, the plurality of frequency ranges may include a frequency range of respiration and a frequency range of heartbeat.

50 [0010] According to a second aspect of the present invention, there is provided a biological information monitoring system for monitoring various biological information on a subject on a bed, the system including: a plurality of load detectors to be placed in the bed or under legs of the bed, each of the plurality of load detectors being configured to detect a load of the subject and output the detected load as a load signal; a signal separation unit configured to separate components each corresponding to each of a plurality of frequency ranges, from the load signal outputted from each of the load detectors; and a center of gravity position calculation unit configured to calculate a center of gravity position of the subject based on the separated components.

55 [0011] In the biological information monitoring system according to the second aspect, the plurality of frequency ranges may include a frequency range of respiration and a frequency range of heartbeat.

[0012] In the biological information monitoring system according to the second aspect, the center of gravity position calculation unit may be configured to calculate the center of gravity position of the subject based on components corresponding to the frequency range of respiration.

[0013] The biological information monitoring system according to the second aspect may further comprise a biological information analysis unit configured to analyze a respiratory condition of the subject based on a temporal variation of the calculated center of gravity position of the subject.

Advantageous Effects of Invention

[0014] According to the biological information monitoring system of the present invention, it is possible to further accurately grasp biological information, for example, a center of gravity position, of the subject on the bed.

BRIEF DESCRIPTION OF THE DRAWINGS

[0015]

Fig. 1 is a block diagram depicting a configuration of a biological information monitoring system according to an embodiment of the present invention.

Fig. 2 is an illustrative view depicting an arrangement of load detectors with respect to a bed.

Fig. 3 is a flow chart depicting a center of gravity locus (trajectory path) calculation method according to the embodiment of the present invention.

Fig. 4 is an illustrative view depicting an arrangement of four load detection areas defined on the upper surface of the bed.

Fig. 5 depicts exemplary load signals fed from the load detectors.

Fig. 6 depicts exemplary locus of the center of gravity of a subject.

Fig. 7 is a flow chart depicting a method for calculating the center of gravity position of a subject on the basis of the respiration component or the heartbeat component which has been separated from each load signal.

Fig. 8 is a block diagram depicting an entire configuration of a bed system according to a modified embodiment.

DESCRIPTION OF EMBODIMENTS

<First Embodiment>

[0016] A first embodiment of the present invention will be explained with reference to Figs. 1 to 7.

[0017] As depicted in Fig. 1, a biological information monitoring system (respiratory waveform drawing system, respiratory information acquiring system) 100 of this embodiment is provided to perform the observation and the measurement in order to grasp the biological state or condition of a subject (a human subject, that is, a person being monitored) on a bed. The biological information monitoring system 100 principally includes a load detecting unit 1, a control unit (a controller) 3, a storage unit (a storage) 4, and a display unit (a display) 5. The load detecting unit 1 and the control unit 3 are connected via an A/D converting unit 2. A notification unit 6 and an input unit 7 are further connected to the control unit 3.

[0018] The load detecting unit 1 is provided with four load detectors 11, 12, 13, 14. Each of the load detectors 11, 12, 13, 14 is a load detector which detects the load by using, for example, a beam-type load cell. Such a load detector is described, for example, in Japanese Patent No. 4829020 and Japanese Patent No. 4002905. Each of the load detectors 11, 12, 13, 14 is connected to the A/D converting unit 2 by means of wiring.

[0019] The four load detectors 11, 12, 13, 14 of the load detecting unit 1 are arranged under the legs of a bed to be used by the subject. Specifically, as depicted in Fig. 2, the load detectors 11, 12, 13, 14 are arranged respectively on the undersides of casters C_1 , C_2 , C_3 , C_4 attached to lower end portions of the legs disposed at the four corners of the bed BD.

[0020] The A/D converting unit 2 is provided with an A/D converter which converts the analog signal fed from the load detecting unit 1 into the digital signal. The A/D converting unit 2 is connected to each of the load detecting unit 1 and the control unit 3 by means of wiring.

[0021] The control unit 3 is an exclusive or general-purpose computer. A frequency analysis unit (a frequency analyzer) 31, a signal separation unit (a signal separator) 32, a center of gravity position calculation unit (a center of gravity position calculator) 33, and a biological information analysis unit (a biological information analyzer) 34 are constructed therein.

[0022] The storage unit 4 is a storage device which stores the data used for the biological information monitoring system 100. For example, it is possible to use a hard disk (magnetic disk) therefore. The display unit 5 is a monitor, such as a liquid crystal monitor, for displaying the information outputted from the control unit 3 for a user of the biological

information monitoring system 100.

[0023] The notification unit 6 is provided with a device for visually or auditorily performing predetermined notification on the basis of the information fed from the control unit 3, for example, a speaker. The input unit 7 is an interface for performing predetermined input for the control unit 3, and may be a keyboard and a mouse.

[0024] It is possible to detect and monitor various biological information, such as the respiratory condition of the subject on the bed, by using the biological information monitoring system 100 described above. The acquisition and the monitoring of various biological information are performed on the basis of the variation of the center of gravity position of the subject on the bed.

[0025] An explanation will be given about the operation for calculating the center of gravity position of the subject on the bed, by using the biological information monitoring system 100. As depicted in Fig. 3, the calculation of the center of gravity position of the subject, which is based on the use of the biological information monitoring system 100, includes a load detecting step (S01) of detecting the load of the subject and a center of gravity locus calculating step (S02) of calculating the temporal variation of the position of the center of gravity of the subject (center of gravity locus) on the basis of the detected load.

[0026] In the load detecting step S01, the load of the subject S on the bed BD is detected, by using the load detectors 11, 12, 13, 14. As the load detectors 11, 12, 13, 14 are arranged respectively on the undersides of the casters C_1 , C_2 , C_3 , C_4 as described above, the load, which is applied to the upper surface of the bed BD, is detected in a dispersed manner by the four load detectors 11, 12, 13, 14. Specifically, as depicted in Fig. 4, the rectangular upper surface of the bed BD is longitudinally divided into two and laterally divided into two, and thus the upper surface is equally divided into four rectangular areas I to IV.

[0027] Accordingly, the load, which is applied to the area I positioned with the left lower half of the body of the subject S lying on his/her back (face up) at the central portion of the bed BD, is principally detected by the load detector 11, and the load, which is applied to the area II positioned with the right lower half of the body of the subject S in the same state, is principally detected by the load detector 12. Similarly, the load, which is applied to the area III positioned with the right upper half of the body of the subject S lying on his/her back at the central portion of the bed BD, is principally detected by the load detector 13, and the load, which is applied to the area IV positioned with the left upper half of the body of the subject S in the same state, is principally detected by the load detector 14. Note that when the subject S does not exist on the bed BD, the total of the outputs from the load detectors 11, 12, 13, 14 represents the weight of the bed itself. When the subject S exists on the bed BD, the total of the outputs from the load detectors 11, 12, 13, 14 represents the weight of the bed and the body weight of the subject S. Therefore, it is possible to measure the body weight of the subject S when the subject S exists on the bed, by previously storing the weight of the bed itself in the storage unit 4. Note that when the weight of the bed is not uniform among the four areas, the difference therebetween is stored beforehand as the bed weight corresponding to each of the load detectors. Further, it is desirable that the situation in which any weight other than that of the subject S is brought about during the actual measurement, for example, the placement of any bedding, any baggage or the like is reflected to the weight of the bed.

[0028] Each of the load detectors 11, 12, 13, 14 detects the load (load change), and the load (load change) is outputted as the analog signal to the A/D converting unit 2. The A/D converting unit 2 converts the analog signal into the digital signal (hereinafter referred to as "load signal") while using the sampling period of, for example, 5 milliseconds, and the load signal is outputted to the center of gravity position calculation unit 33 not through the frequency analysis unit 31 and the signal separation unit 32.

[0029] Exemplary load signals are depicted in Fig. 5. Fig. 5 depicts the load signals s_1 (solid line), s_2 (broken line), s_3 (alternate long and short dash line), and s_4 (alternate long and two short dashes line) fed from the load detectors 11, 12, 13, 14 as outputted during the period ranging from the time t_{10} to the time t_{14} . The following fact has been observed. That is, the subject S lay on his/her back at the central portion of the bed BD as depicted in Fig. 4 during the period ranging from the time t_{10} to the time t_{11} (period P_{11}). The subject S moved to the side of the areas I, IV of the bed BD during the period ranging from the time t_{11} to the time t_{12} (period P_{12}). The subject S moved to some extent to the central side of the bed BD during the period ranging from the time t_{12} to the time t_{13} (period P_{13}) as compared with the period P_{12} . The subject S lay on his/her back at the central portion of the bed BD during the period ranging from the time t_{13} to the time t_{14} (period P_{14}).

[0030] During the period P_{11} , the subject S lay on his/her back at the central portion of the bed BD as depicted in Fig. 4. Therefore, during the period P_{11} , the signals s_3 , s_4 , which are fed from the load detectors 13, 14 arranged on the head side of the subject S, are approximately equal to one another, and the signals s_1 , s_2 , which are fed from the load detectors 11, 12 arranged on the foot side of the subject S, are approximately equal to one another.

[0031] During the period P_{12} , the subject S moved to the side of the areas I, IV of the bed BD. Therefore, during the period P_{12} , the signals s_1 , s_4 , which are fed from the load detectors 11, 14 arranged in the areas I, IV, exhibit the large load values as compared with the period P_{11} , and the signals s_2 , s_3 , which are fed from the load detectors 12, 13 arranged in the areas II, III, exhibit the small load values as compared with the period P_{11} .

[0032] During the period P_{13} , the subject S moved to some extent to the central side of the bed BD as compared with

the period P_{12} . Therefore, during the period P_{13} , the signals s_1, s_4 , which are fed from the load detectors 11, 14 arranged in the areas I, IV, exhibit the small load values as compared with the period P_{12} , and the signals s_2, s_3 , which are fed from the load detectors 12, 13 arranged in the areas II, III, exhibit the large load values as compared with the period P_{12} .

[0033] During the period P_{14} , the subject S lay on his/her back at the central portion of the bed BD in the same manner as the period P_{11} . Therefore, during the period P_{14} , the signals s_1 to s_4 , which are provided during the period P_{14} , are the same as the signals s_1 to s_4 provided during the period P_{11} .

[0034] In the center of gravity locus calculating step S02, the center of gravity position calculation unit 33 calculates the position G (X, Y) of the center of gravity G of the subject S on the bed BD at a predetermined period T (for example, a period equal to the sampling period of 5 milliseconds described above) on the basis of the load signals s_1 to s_4 fed from the load detectors 11 to 14 to acquire (obtain) the temporal variation of the position of the center of gravity G of the subject S (center of gravity locus GT). In this case, (X, Y) indicates the coordinates on the XY coordinate plane in which X extends in the longitudinal direction of the bed BD and Y extends in the lateral direction of the bed BD while the central portion of the bed BD is the origin (Fig. 6).

[0035] The calculation of the position G (X, Y) of the center of gravity G by the center of gravity position calculation unit 31 is performed in accordance with the following operation. That is, G (X, Y) is calculated in accordance with the following expressions assuming that the coordinates of the load detectors 11, 12, 13, 14 are (X_{11}, Y_{11}) , (X_{12}, Y_{12}) , (X_{13}, Y_{13}) , and (X_{14}, Y_{14}) respectively, and the detection values of the load detectors 11, 12, 13, 14 are W_{11} , W_{12} , W_{13} , and W_{14} respectively.

(Numerical expression 1)

$$X = \frac{X_{11} \times W_{11} + X_{12} \times W_{12} + X_{13} \times W_{13} + X_{14} \times W_{14}}{W_{11} + W_{12} + W_{13} + W_{14}}$$

(Numerical expression 2)

$$Y = \frac{Y_{11} \times W_{11} + Y_{12} \times W_{12} + Y_{13} \times W_{13} + Y_{14} \times W_{14}}{W_{11} + W_{12} + W_{13} + W_{14}}$$

[0036] The center of gravity position calculation unit 33 acquires the temporal variation of the position G (X, Y) of the center of gravity G, i.e., the center of gravity locus GT while calculating the position G (X, Y) of the center of gravity G at the predetermined sampling period T on the basis of the numerical expressions (1) and (2) described above. The acquired center of gravity locus GT is stored, for example, in the storage unit 4.

[0037] An example of the center of gravity locus GT calculated by the center of gravity position calculation unit 33 is depicted in Fig. 6. Fig. 6 depicts the positions G (X_{P11}, Y_{P11}) , G (X_{P12}, Y_{P12}) , G (X_{P13}, Y_{P13}) of the center of gravity G of the subject S on the bed BD at the time t_{110} , t_{120} , t_{130} included in the periods P_{11} , P_{12} , P_{13} depicted in Fig. 5 respectively. An arrow of alternate long and short dash line to connect these positions indicates the center of gravity locus GT of the center of gravity G of the subject S moving from the position G (X_{P11}, Y_{P11}) to G (X_{P13}, Y_{P13}) .

[0038] In this embodiment, the biological information analysis unit 34 analyzes the presence or absence of a body motion of the subject S and the manner of a body motion of the subject S on the basis of the center of gravity locus GT of the subject S calculated as above by the center of gravity position calculation unit 33. Specifically, for example, the biological information analysis unit 34 calculates the movement speed (movement amount per unit time) of the center of gravity G on the basis of the changes in the position of the center of gravity G of the subject S at the respective points in time, stored in the storage unit 4, and when the calculated speed exceeds a predetermined threshold, the biological information analysis unit 34 determines that the subject S has performed a body motion. Note that a body motion of the subject S includes a body motion caused by a relatively large movement of the body involving the movement of the body portion (body trunk) of the subject S (large body motion), such as turning over, and a body motion caused by a relatively small movement of the body not involving the movement of the body portion of the subject S (small body motion), such as movement of hands, feet, and/or face. A large body motion is, specifically, turning over, sitting up or the like. When a large body motion occurs to the subject, the direction of the body axis of the subject (the direction in which the backbone of the subject extends) changes in general. A small body motion is, specifically, for example, the movement only of hands, feet, and/or head.

[0039] When the large body motion is defined in view of the manner of the temporal variation of the position of the center of gravity, the large body motion can be defined in general to be the movement of the center of gravity for a relatively long distance exceeding a predetermined distance, which occurs within a predetermined time period. Alternatively, it is also possible to define, on the basis of the difference from the temporal variation of the position of the center of gravity caused by the small body motion, for example, that the large body motion is the body motion in which the center of gravity is moved, within a predetermined time period, at least nearly predetermined times as greatly as the movement distance of the center of gravity by the small body motion. Further, it is also allowable to define, by comparing with the amplitude of the respiratory oscillation as described later on.

[0040] When the small body motion is defined in view of the manner of the temporal variation of the position of the center of gravity, the small body motion can be defined in general to be the movement of the center of gravity for a relatively short distance within a predetermined time period. Further, it is also allowable to define, by comparing with the amplitude of the respiratory oscillation as described later on. Further, it is also allowable to define that the small body motion is the body motion to cause the movement of the center of gravity for a relatively short distance within a predetermined time period, the movement of the center of gravity not being an oscillation in a constant direction. According to this definition, when an attention is paid to the movement of the center of gravity, it is possible to further clearly distinguish the small body motion from the respiration.

[0041] Here, in the center of gravity locus calculating step S02, as depicted in the numerical expressions (1) and (2) described above, the center of gravity position $G(X, Y)$ is calculated on the basis of the entire loads W_{11} , W_{12} , W_{13} , and W_{14} detected by the load detectors 11, 12, 13, 14 respectively. Accordingly, for example, when any object is placed in a position away from the subject S on the bed, the center of gravity position $G(X, Y)$ calculated by the numerical expressions (1) and (2) described above may be displaced (deviated) from the actual center of gravity position of the subject S, by the influence of the load of the object which has been placed on the bed. For this reason, in this embodiment, the components included in a specified frequency range (band) are separated from each of the load signals s_1 to s_4 outputted from the load detectors 11 to 14 to also calculate the center of gravity position of the subject S on the basis of the separated components.

[0042] In the following, with reference to the flow chart in Fig. 7, an explanation will be given about the process of separating the components included in the frequency range of respiration (about 0.2 Hz to about 0.33 Hz) from each of the load signals s_1 to s_4 , and calculating the center of gravity position of the subject S on the basis of the separated components.

[0043] In a frequency analyzing step S10, the frequency analysis unit 31 acquires a frequency spectrum by performing the Fourier transformation of each or at least one of the load signals s_1 to s_4 outputted from the load detectors 11 to 14.

[0044] In a signal separating step S20, the signal separation unit 32 specifies a peak frequency included in the frequency range of respiration (i.e., frequency of the respiration of the subject S) based on the frequency spectrum acquired in the frequency analyzing step S10. Then, the signal separation unit 32 separates components S_{b1} to S_{b4} (hereinafter referred to as "respiration components"), corresponding to the specified peak frequency, from the load signals s_1 to s_4 respectively.

[0045] In a center of gravity position calculating step S30, the center of gravity position calculation unit 33 calculates the center of gravity position $G_b(X, Y)$ of the subject S on the bed in accordance with the numerical expressions (1) and (2) described above, on the basis of the respiration components S_{b1} to S_{b4} separated in the signal separating step 20.

[0046] In a biological information analyzing step S40, the biological information analysis unit 34 may adopt either of the center of gravity position $G(X, Y)$ calculated on the basis of the entire loads and the center of gravity position $G_b(X, Y)$ (respiratory center of gravity, center of gravity of respiration) calculated on the basis of the respiration components S_{b1} to S_{b4} . For example, after comparison of the center of gravity position $G(X, Y)$ calculated on the basis of the entire loads with the center of gravity position $G_b(X, Y)$ calculated on the basis of the respiration components S_{b1} to S_{b4} , the biological information analysis unit 34 may determine which to adopt as the center of gravity position of the subject S. Alternatively, the distance between the center of gravity position $G(X, Y)$ based on the entire loads and the center of gravity position $G_b(X, Y)$ based on the respiration components is calculated, and when the calculated distance exceeds a predetermined range, the biological information analysis unit 34 may adopt the center of gravity position $G_b(X, Y)$ based on the respiration components as the center of gravity position of the subject S. In this case, the predetermined range may be appropriately set in consideration of, for example, the dimension(s) of the bed, the body height and weight of the subject S, and the like.

[0047] The biological information analysis unit 34 analyzes various biological information of the subject S by using the adopted center of gravity position.

[0048] By the way, the respiration of human is performed by moving the chest and the diaphragm to expand and shrink the lungs. In this context, when the air is inhaled, i.e., when the lungs are expanded, the diaphragm is lowered downwardly, and the internal organs are also moved downwardly. On the other hand, when the air is expired, i.e., when the lungs are shrunk, the diaphragm is raised upwardly, and the internal organs are also moved upwardly. As a result of the research performed by the inventors of the present invention, it has been found out that in accordance with the movement of the internal organs, the center of gravity G oscillates approximately along the extending direction of the backbone

(body axis direction) (hereinafter referred to as "respiratory oscillation").

[0049] Therefore, when the center of gravity position is subject to the respiratory oscillation in a specified direction, the biological information analysis unit 34 regards the specified direction as the direction of the body axis of the subject S, and determines the posture of the subject S on the bed (whether the body axis is parallel to the longitudinal direction of the bed or inclined with respect to the longitudinal direction of the bed). The direction of the respiratory oscillation can be specified, for example, by specifying a certain extreme point (extreme value point) and an extreme point appearing immediately before or immediately after the certain extreme point from the locus of the respiration oscillation, and acquiring the axis connecting both of the extreme points.

[0050] Further, the biological information analysis unit 34 draws a respiratory waveform of the subject S with a longitudinal axis as a direction of the body axis and a lateral axis as a time axis, by plotting distances, each between the center of oscillation of the respiratory oscillation and the position obtained by projecting the center of gravity position at each point in time to the body axis. Then, the biological information analysis unit 34 counts the number of maximum values or minimum values appearing on the respiratory waveform to thereby determine the respiration rate of the subject S. Furthermore, based on the amplitude of the center of gravity position (i.e., amplitude of the respiratory oscillation, or amplitude of the respiratory waveform), the biological information analysis unit 34 calculates a respiratory ventilation volume (tidal volume) per one respiration of the subject S (depth of the respiration).

[0051] Next, with reference to the flow chart in Fig. 7, an explanation will be given about the process of separating the components included in the frequency range of heartbeat (about 0.5 Hz to about 3.3 Hz; hereinafter referred to as "heartbeat range") from each of the load signals s_1 to s_4 , and calculating the center of gravity position of the subject S on the basis of the separated components. Note that this process may be carried out in parallel to the calculation of the center of gravity position G_b (X, Y) based on the respiration components described above, or may be solely carried out.

[0052] In the frequency analyzing step S10, the frequency analysis unit 31 acquires a frequency spectrum in the heartbeat range, by performing the Fourier transformation of each or at least one of the load signals s_1 to s_4 outputted from the load detectors 11 to 14.

[0053] In the signal separating step S20, the signal separation unit 32 specifies a peak frequency included in the heartbeat range (i.e., frequency of the heartbeat of the subject S) based on the frequency spectrum acquired in the frequency analyzing step S10. Then, the signal separation unit 32 separates the components s_{h1} to s_{h4} (hereinafter referred to as "heartbeat components"), corresponding to the specified peak frequency, from each of the load signals s_1 to s_4 .

[0054] In the center of gravity position calculating step S30, the center of gravity position calculation unit 33 calculates the center of gravity G of the subject S on the bed in accordance with the numerical expressions (1) and (2) described above, on the basis of the heartbeat components s_{h1} to s_{h4} separated in the signal separating step 20 (hereinafter such center of gravity G referred to as "center of gravity G_h based on the heartbeat components (heartbeat center of gravity, center of gravity of heartbeat)").

[0055] The center of gravity G_h based on the heartbeat components of the subject S on the bed as calculated by using the heartbeat components s_{h1} to s_{h4} separated from the load signals s_1 to s_4 have the following characteristics.

(1) The center of gravity G_h based on the heartbeat components is calculated by using only the heartbeat components s_{h1} to s_{h4} , among the load signals s_1 to s_4 , which oscillate corresponding to the heartbeat of the subject S. Consequently, for example, in the case that a load by a third party (such as a visitor) whose heartbeat has a frequency different from that of the heartbeat of the subject S, or a load by an inanimate object (such as a bag) having no heartbeat is added on the bed BD, the center of gravity G_h based on the heartbeat components remains unmoved, and the center of gravity G_b based on the heartbeat components moves only in the case that the subject S has moved.

(2) As a result of the observation, by the inventors of the present invention, of the locus of movement of the center of gravity G_h based on the heartbeat components, it has been found out that the center of gravity G_h based on the heartbeat components slightly oscillates along the direction obtained by rotating the body axis of the subject S counterclockwise to some degree. This oscillation (hereinafter referred to as "heartbeat oscillation") is considered to be caused by the beating of the heart.

[0056] In the biological information analyzing step S40, the biological information analysis unit 34 may compare the center of gravity position G (X, Y) calculated on the basis of the entire loads with the position of the center of gravity G_h based on the heartbeat components, and determine which to adopt as the center of gravity position of the subject S. This determination can be made in accordance with the method same as or equivalent to the method explained above concerning the center of gravity position G_b (X, Y) based on the respiration components.

[0057] Further, the biological information analysis unit 34 can also determine whether or not the subject S exists on the bed BD, namely, make a presence-on-bed determination, on the basis of whether or not it is possible to acquire the center of gravity G_h based on the heartbeat components. When the subject S does not exist on the bed BD, the components, which vary according to the heartbeat of the subject S, do not exist in each of the signal components s_1 to s_4

of the load detectors 11 to 14. Consequently, it is not possible to separate such components, and it is not possible to calculate the center of gravity G_h based on the heartbeat components. For this reason, the presence-on-bed determination can be made on the basis of the presence or absence of the heartbeat components or whether or not it is possible to calculate the center of gravity G_h based on the heartbeat components. The biological information analysis unit 34 may

determine that the subject S exists on the bed, for example, when it is confirmed that the calculated center of gravity G_h based on the heartbeat components exists on the bed BD. More precisely, when it is confirmed that the center of gravity G_h based on the heartbeat components is oscillating in a predetermined direction which is inclined with respect to the body axis of the subject S, the biological information analysis unit 34 may determine that the subject S exists on the bed.

[0058] Furthermore, the biological information analysis unit 34 can acquire the direction of the body axis of the subject S, on the basis of the direction of oscillation of the center of gravity G_h based on the heartbeat components, and can also acquire a heart rate, on the basis of the oscillation rate per one minute of the center of gravity G_h based on the heartbeat components.

[0059] The effects of the biological information monitoring system 100 of this embodiment are summarized as follows.

[0060] The signal separation unit 32 of this embodiment separates, for example, the respiration components included in the frequency range of respiration and the heartbeat components included in the frequency range of heartbeat, from each of the load signals s_1 to s_4 outputted from the load detectors 11 to 14. By using these components, it is possible to further accurately acquire (grasp) biological information of the subject S.

[0061] The center of gravity position calculation unit 33 of this embodiment calculates not only the center of gravity position $G(X, Y)$ calculated on the basis of the entire loads, but also the center of gravity position $G_b(X, Y)$ based on the respiration components and the center of gravity position $G_h(X, Y)$ based on the heartbeat components. Consequently, the biological information analysis unit 34 can utilize the center of gravity position $G_b(X, Y)$ based on the respiration components and the center of gravity position $G_h(X, Y)$ based on the heartbeat components for analyzing various biological information of the subject S. The center of gravity position $G_b(X, Y)$ based on the respiration components and the center of gravity position $G_h(X, Y)$ based on the heartbeat components remain unchanged when a load not deriving from the subject S, such as a load of baggage or a visitor, is added on the bed BD, so that using these center of gravity positions makes it possible to further accurately analyze biological information of the subject S.

[0062] For example, by using the center of gravity position $G_b(X, Y)$ based on the respiration components, the biological information analysis unit 34 can analyze the posture (body axis direction) of the subject S on the bed and the respiratory condition such as respiratory waveform (respiration waveform), respiratory rate (respiration rate), and respiratory ventilation volume.

[0063] Further, based on the presence or absence of the heartbeat components or the center of gravity G_h based on the heartbeat components, the biological information analysis unit 34 can make a presence-on-bed determination with respect to the subject S. Unlike the respiration, the heartbeat cannot be stopped consciously (deliberately, intentionally), and thus, present (exist, settling) on/leaving (absent) from the bed of the subject S can be further reliably determined, by making a presence-on-bed determination on the basis of the presence or absence of the heartbeat components or the center of gravity G_h based on the heartbeat components.

[0064] The biological information monitoring system 100 of this embodiment acquires biological information of the subject S by using the load detectors 11 to 14 arranged under the legs of the bed BD. Therefore, it is unnecessary to attach any measuring device to the body of the subject S. Neither discomfort nor sense of incongruity is given to the subject S.

<Modified Embodiment>

[0065] In the biological information monitoring system 100 of the embodiment described above, the following modified embodiment may be adopted.

[0066] For example, the respiratory cycle (cycle of the respiration) differs depending on the sex (gender), physique (physical constitution), lung capacity and the like of a subject S, and the heartbeat cycle (cycle of the heartbeat) also differs from person to person. Consequently, when a plurality of subjects S exist on the bed BD, different peak frequencies as many as the number of the subjects S appear in the frequency range of respiration and/or the frequency range of heartbeat in the frequency spectrum acquired in the frequency analyzing step S10.

[0067] In view of the above, when a plurality of peak frequencies appear in the frequency range of respiration and/or the frequency range of heartbeat, the signal separation unit 32 may determine that a plurality number of subjects S are on the bed, and separate the respiration components and/or the heartbeat components corresponding to each of the subjects S, from each of the load signals s_1 to s_4 . Then, the center of gravity position calculation unit 33 may calculate the center of gravity position of each of the subjects S on the basis of the respiration components and/or the heartbeat components corresponding to each of the subjects S. For example, when a peak appears in each of a frequency v_1 and a frequency v_2 in the frequency range of respiration, the signal separation unit 32 determines that two subjects S are on the bed. In the signal separating step S20, the signal separation unit 32 separates the respiration components

corresponding to the frequency v_1 and the respiration components corresponding to the frequency v_2 , from each of the load signals s_1 to s_4 . Then, in the center of gravity position calculating step S30, the center of gravity position calculation unit 33 calculates the center of gravity position $G_{b1}(X, Y)$ based on the respiration components corresponding to the peak frequency v_1 and the center of gravity position $G_{b2}(X, Y)$ based on the respiration components corresponding to the peak frequency v_2 .

[0068] According to the modified embodiment described above, even when a plurality number of subjects S are on the bed, it is possible to separately acquire the center of gravity G_b based on the respiration of each of the subjects S and the center of gravity G_h based on the heartbeat of each of the subjects S, and the center of gravity position of each of the subjects S can be accurately grasped.

[0069] In the biological information monitoring system 100 of the embodiment described above, the biological information analysis unit 34 may determine that the subject S has settled on the bed, when the load added to the bed BD increases by at least a predetermined value (for example, about 40 kg) and the heart beat components or the center of gravity G_h based on the heartbeat have/has been acquired. The biological information analysis unit 34 may determine that the subject S has left the bed, when the load added to the bed BD decreases by at least a predetermined value and the heart beat components or the center of gravity G_h based on the heartbeat are/is unable to be acquired.

[0070] Note that when there exists on the bed BD an element striking the bed BD with a predetermined period or cycle (impact element), waveform having such predetermined period or cycle appears in each of the load signals s_1 to s_4 fed from the load detectors 11 to 14, four waveforms in the load signals s_1 to s_4 having phases identical to each other. If a load component including such waveform is separated by using the frequency analysis unit 31 and the signal separation unit 32, and the separated load component is used for the center of gravity position calculation unit 33 to calculate a center of gravity position, it is possible to calculate the center of gravity position of the impact element.

[0071] In the embodiment described above, each of the load detectors 11, 12, 13, 14 is not limited to the load sensor having the beam-type load cell. It is also possible to use, for example, a force sensor.

[0072] In the embodiment described above, the number of load detectors is not limited to four. It is also allowable to use five or more load detectors by providing an additional leg or additional legs for the bed BD. Alternatively, it is also allowable to arrange the load detectors for only three of the legs of the bed BD. Even when the three load detectors are used, it is possible to detect a position of the center of gravity G of the subject S on the plane of the bed BD provided that the three load detectors are not arranged on a straight line.

[0073] In the embodiment described above, the load detectors 11, 12, 13, 14 are arranged respectively on the under-sides of the casters C_1, C_2, C_3, C_4 attached to the lower ends of the legs of the bed BD. However, there is no limitation thereto. Each of the load detectors 11, 12, 13, 14 may be provided respectively between one of the four legs of the bed BD and the board of the bed BD. Alternatively, if each of the four legs of the bed BD can be divided into upper and lower portions, each of the load detectors 11, 12, 13, 14 may be provided between upper leg and lower leg. Further alternatively, the load detectors 11, 12, 13, 14 may be formed integrally with the bed BD to construct a bed system BDS comprising the bed BD and the biological information monitoring system 100 of this embodiment (Fig. 8). Note that in this specification, the "load detectors placed in the bed" means the load detectors each of which is provided between one of the four legs of the bed BD and the board of the bed BD as described above and the load detectors each of which is provided between the upper leg and the lower leg.

[0074] In the embodiment described above, it is also allowable to provide a signal amplifying unit for amplifying the load signal fed from the load detecting unit 1 and/or a filtering unit for removing the noise from the load signal, between the load detecting unit 1 and the A/D converting unit 2.

[0075] In the biological information monitoring system 100 of the embodiment described above, the display unit 5 is not limited to the unit which displays the information on the monitor so that the user can make the visual recognition. For example, the display unit 5 may be a printer which periodically prints and outputs the respiratory condition (respiratory rate, respiratory ventilation volume), the state of the heartbeat, and the physical condition of the subject S. Alternatively, the display unit 5 may be a unit which performs the display by using any simple visual expression, for example, such that a blue lamp is turned ON in the case of the presence-on-bed state and/or a red lamp is turned ON in the case of the bed-leaving state. Further alternatively, the display unit 5 may be a unit which reports the biological information of the subject S to the user by means of any sound or voice. Further alternatively, it is also allowable that the biological information monitoring system 100 does not have the display unit 5. The biological information monitoring system 100 may have only an output terminal for outputting the information. A monitor (display device) or the like, which is provided to perform the display, will be connected to the biological information monitoring system 100 by the aid of the output terminal.

[0076] The notification unit 6 of the embodiment described above performs the notification auditorily. However, the notification unit 6 may be constructed to perform the notification visually by means of, for example, the flashing or flickering of light. Alternatively, the notification unit 6 may be constructed to perform the notification by means of the vibration. Further, it is also allowable that the biological information monitoring system 100 of the embodiment described above does not have the notification unit 6.

[0077] The present invention is not limited to the embodiments described above provided that the feature of the present invention is maintained. Other embodiments, which are conceivable within the scope of the technical concept of the present invention, are also included in the scope of the present invention.

5 INDUSTRIAL APPLICABILITY

[0078] According to a biological information monitoring system of the present invention, it is possible to further accurately acquire the center of gravity position of the subject, and it is therefore possible to provide the data suitable for the observation by the user who is principally a doctor and contribute to the improvement of the quality of the medical treatment.

10 PARTS LIST

[0079] 1: load detecting unit, 11, 12, 13, 14: load detector, 2: A/D converting unit, 3: control unit, 31: frequency analysis unit, 32: signal separation unit, 33: center of gravity position calculation unit, 34: biological information analysis unit, 4: storage unit, 5: display unit, 6: notification unit, 7: input unit, 100: biological information monitoring system, BD: bed, BDS: bed system, GT: center of gravity locus, S: subject.

20 Claims

1. A biological information monitoring system for monitoring biological information on subjects on a bed, the system comprising:

25 a plurality of load detectors to be placed in the bed or under legs of the bed, each of the plurality of load detectors being configured to detect loads of the subjects and output the detected loads as a load signal; and
a signal separation unit configured to determine a number of the subjects on the bed based on a frequency spectrum of the load signal outputted from each of the plurality of load detectors, and separate, with respect to each of the subjects, components each corresponding to each of a plurality of frequency ranges from the load signal outputted from each of the plurality of load detectors.

30 2. The biological information monitoring system according to claim 1, wherein the signal separation unit is configured to determine that the number of peak frequencies appeared in the frequency spectrum is the number of the subjects on the bed.

35 3. The biological information monitoring system according to claim 1 or 2, wherein the plurality of frequency ranges include a frequency range of respiration and a frequency range of heartbeat.

40 4. A biological information monitoring system for monitoring various biological information on a subject on a bed, the system comprising:

45 a plurality of load detectors to be placed in the bed or under legs of the bed, each of the plurality of load detectors being configured to detect a load of the subject and output the detected load as a load signal;
a signal separation unit configured to separate components each corresponding to each of a plurality of frequency ranges, from the load signal outputted from each of the load detectors; and
a center of gravity position calculation unit configured to calculate a center of gravity position of the subject based on the separated components.

50 5. The biological information monitoring system according to claim 4, wherein the plurality of frequency ranges include a frequency range of respiration and a frequency range of heartbeat.

6. The biological information monitoring system according to claim 5, wherein the center of gravity position calculation unit is configured to calculate the center of gravity position of the subject based on components corresponding to the frequency range of respiration.

55 7. The biological information monitoring system according to claim 6, further comprising a biological information analysis unit configured to analyze a respiratory condition of the subject based on a temporal variation of the calculated center of gravity position of the subject.

Fig. 1

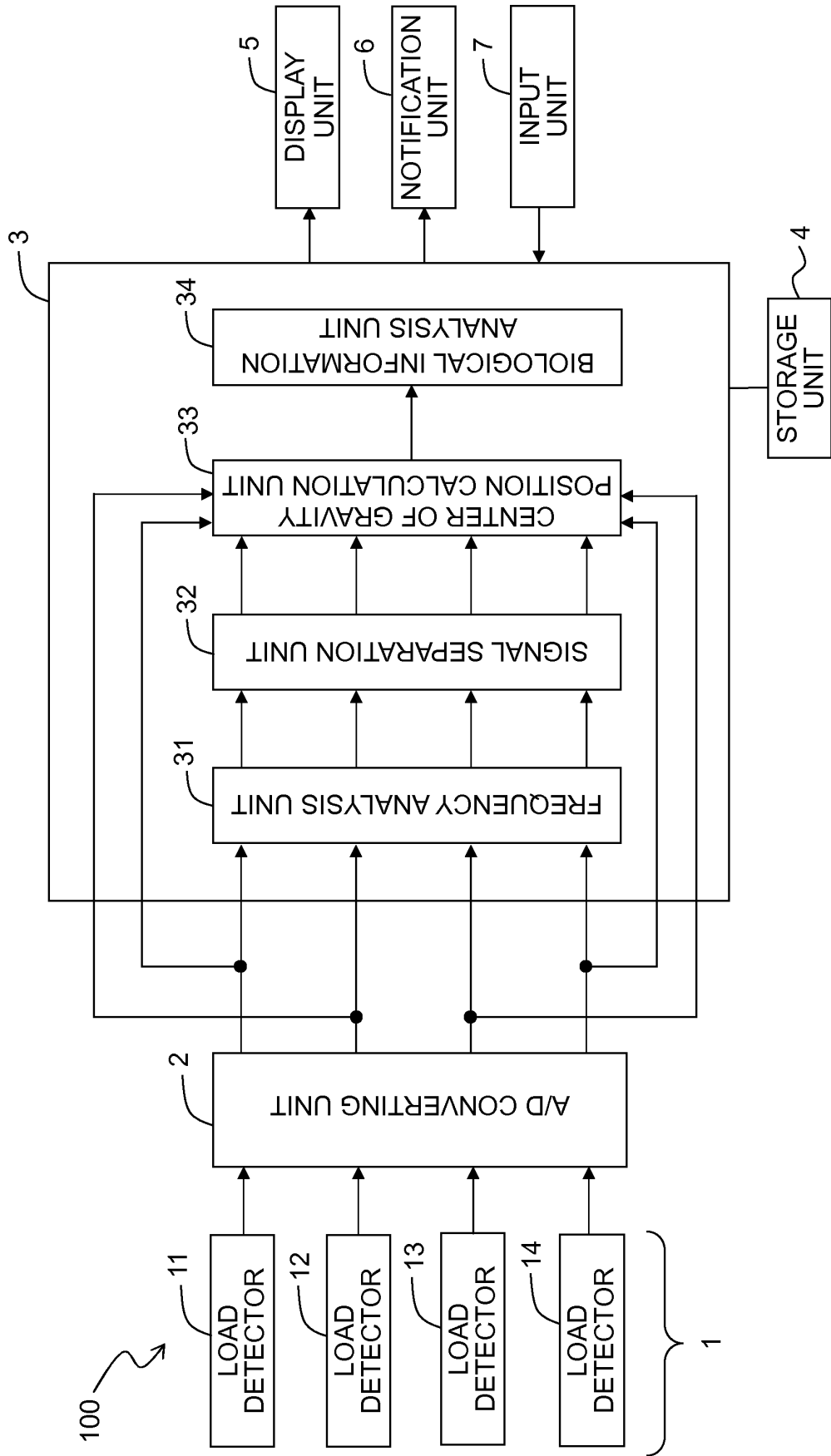

Fig. 2

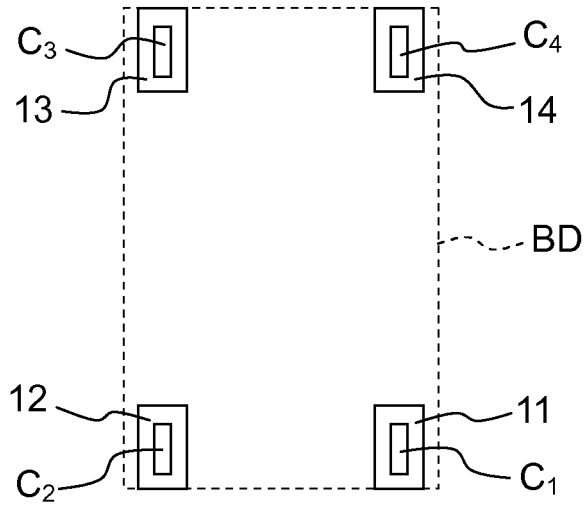

Fig. 3

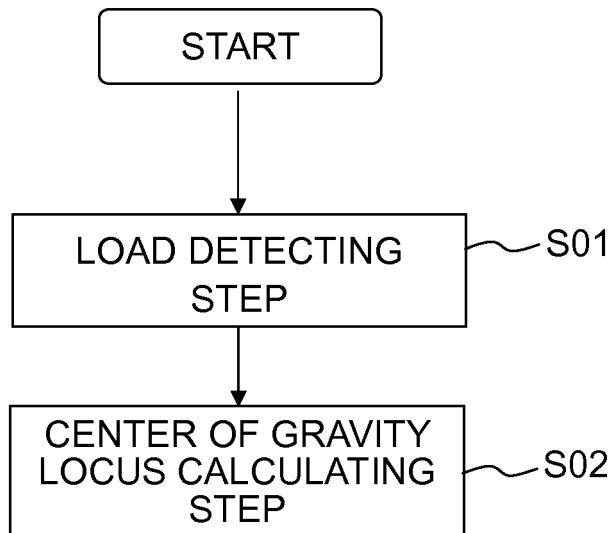

Fig. 4

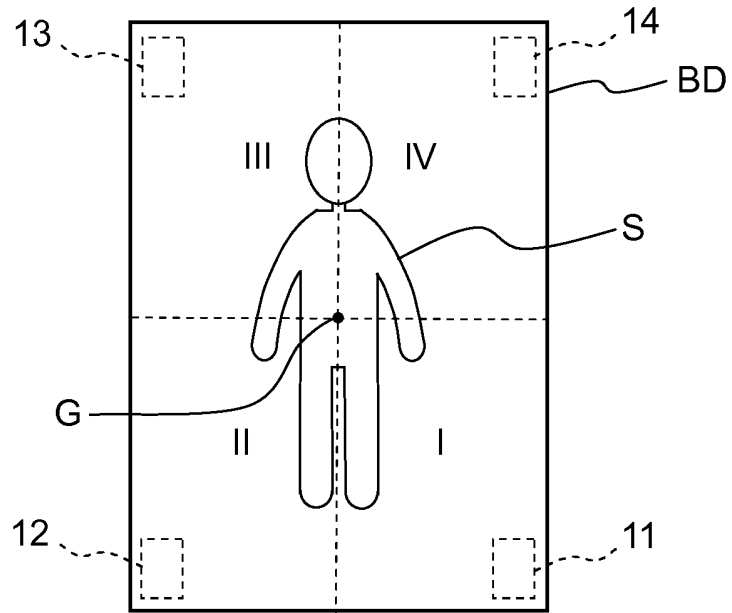

Fig. 5

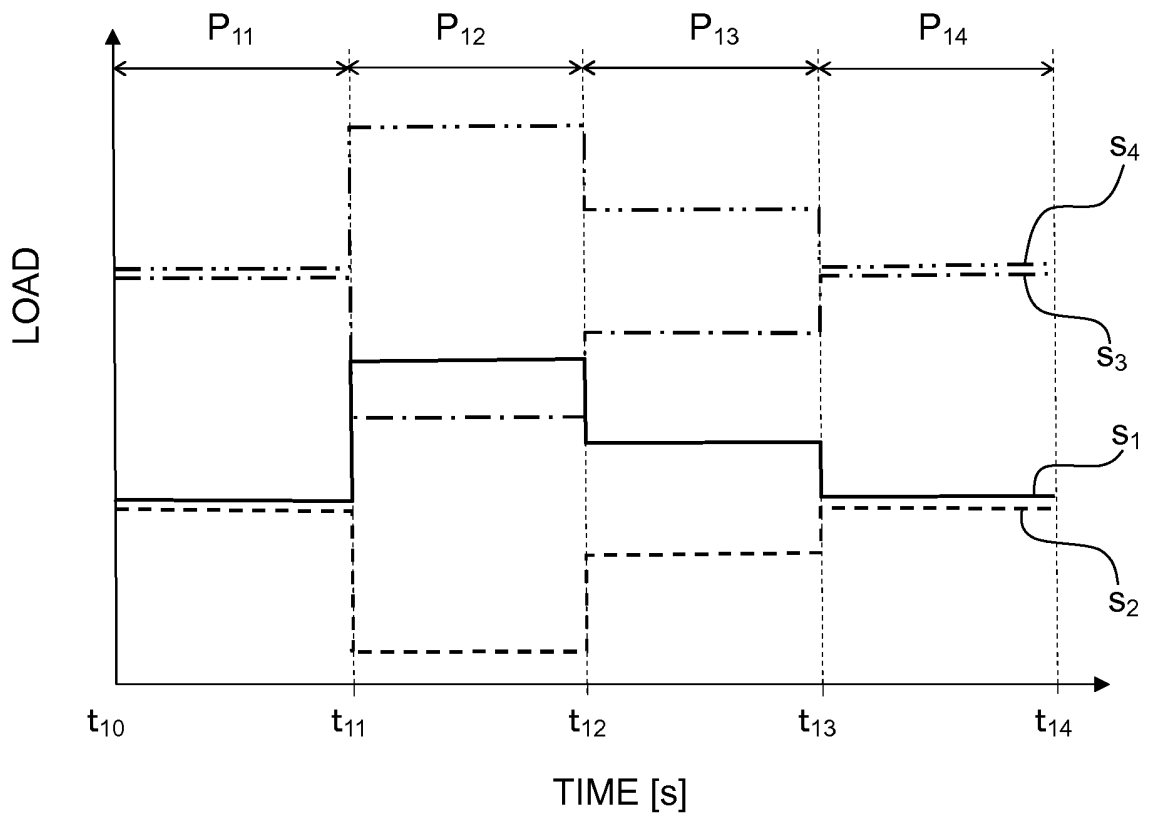

Fig. 6

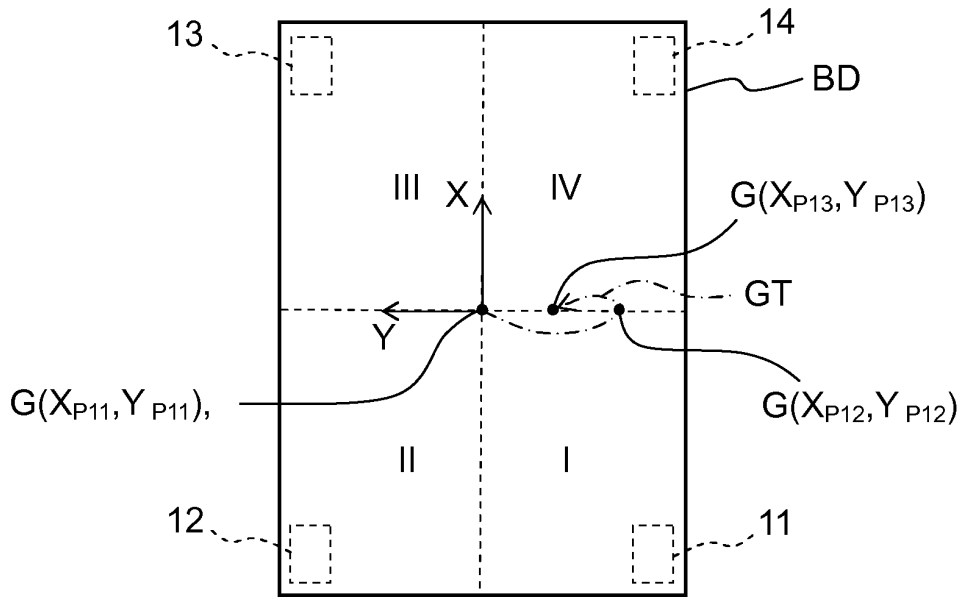
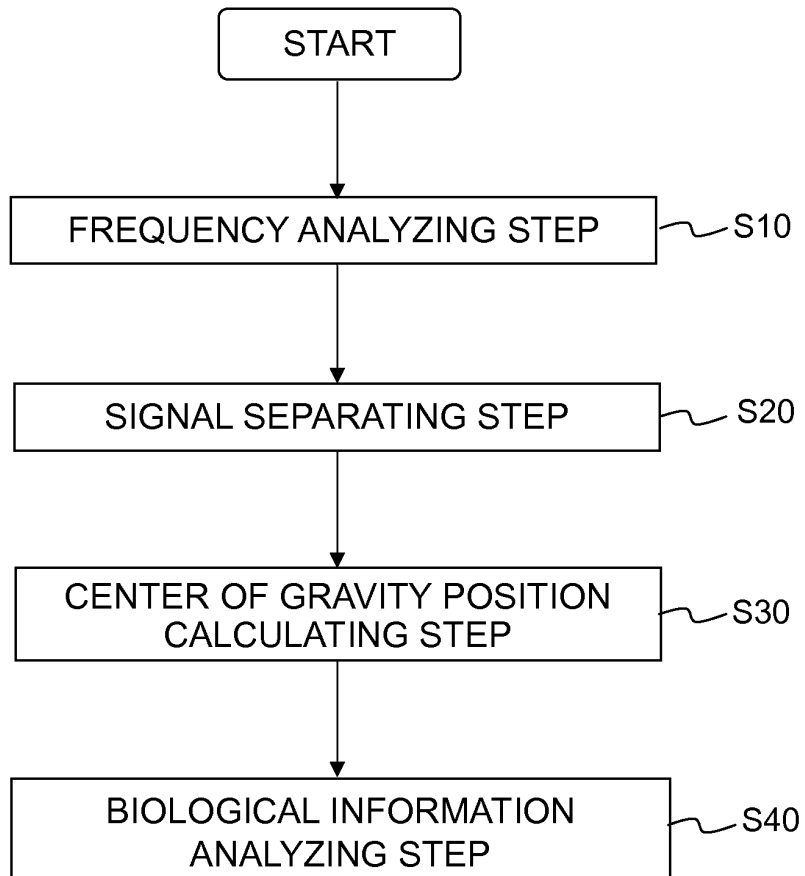

Fig. 7



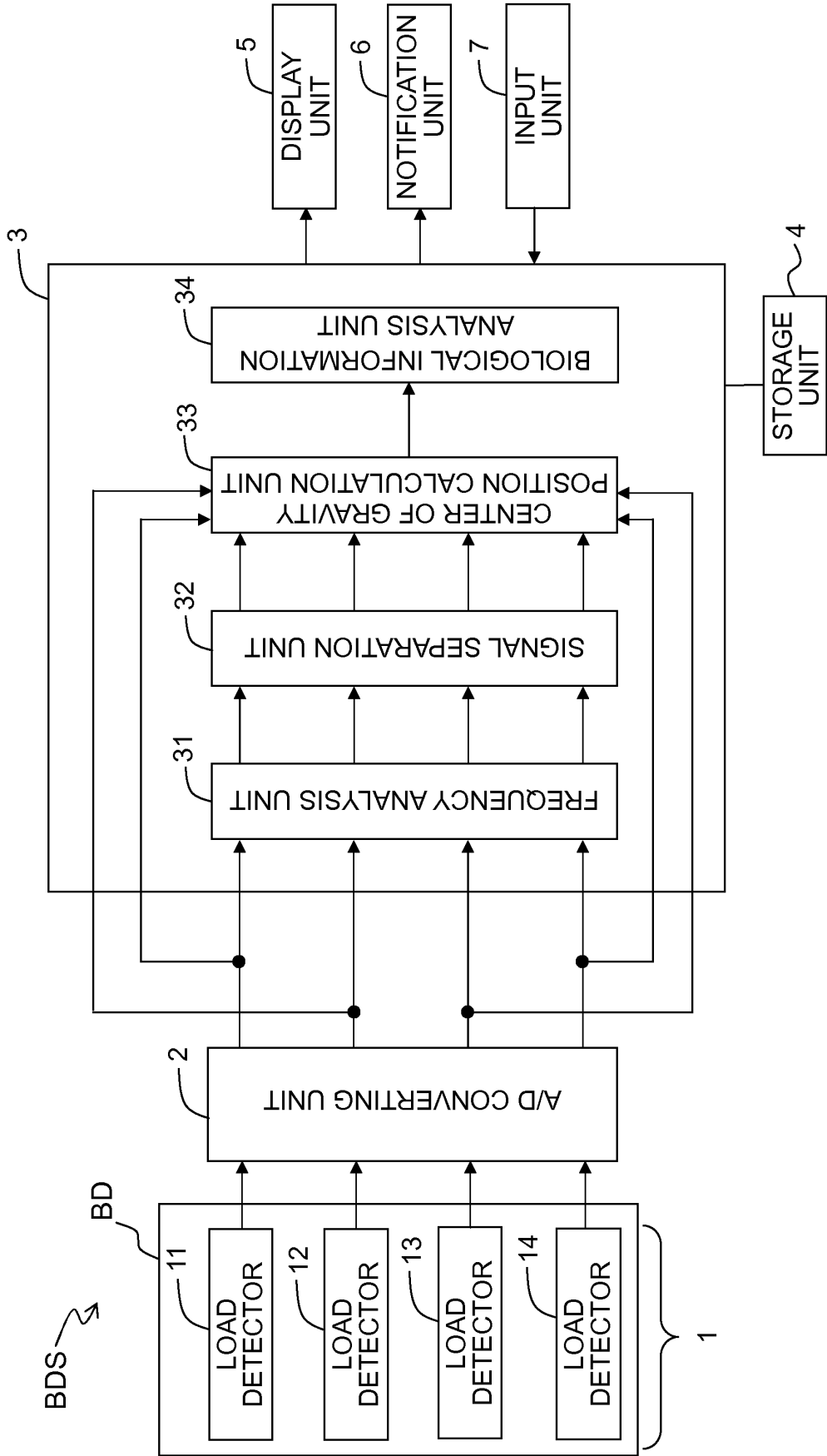

Fig. 8

BDS

BD

INTERNATIONAL SEARCH REPORT

International application No.

PCT/JP2017/018542

5	A. CLASSIFICATION OF SUBJECT MATTER A61B5/11(2006.01)i, A61B5/00(2006.01)i, A61B5/0245(2006.01)i, A61B5/08(2006.01)i, A61B5/113(2006.01)i, A61G7/05(2006.01)i, G08B21/06(2006.01)i, G08B21/22(2006.01)i According to International Patent Classification (IPC) or to both national classification and IPC	
10	B. FIELDS SEARCHED Minimum documentation searched (classification system followed by classification symbols) A61B5/11, A61B5/00, A61B5/0245, A61B5/08, A61B5/113, A61B5/16, A61G7/05, G08B21/06, G08B21/22	
15	Documentation searched other than minimum documentation to the extent that such documents are included in the fields searched Jitsuyo Shinan Koho 1922-1996 Jitsuyo Shinan Toroku Koho 1996-2017 Kokai Jitsuyo Shinan Koho 1971-2017 Toroku Jitsuyo Shinan Koho 1994-2017	
20	Electronic data base consulted during the international search (name of data base and, where practicable, search terms used) PubMed	
25	C. DOCUMENTS CONSIDERED TO BE RELEVANT	
30	Category*	Citation of document, with indication, where appropriate, of the relevant passages
35		Relevant to claim No.
40	A	WO 2015/078937 A1 (KONINKLIJKE PHILIPS N.V.), 04 June 2015 (04.06.2015), description, page 4, lines 3 to 6; page 10, lines 5 to 9 & JP 2017-500927 A & US 2016/0270721 A1 & EP 3073901 A1 & CN 105792733 A
45	A	JP 2016-30030 A (Sharp Corp.), 07 March 2016 (07.03.2016), entire text; all drawings (Family: none)
50	A	US 4657025 A (ORLANDO, Carl), 14 April 1987 (14.04.1987), entire text; all drawings & US 4738264 A
55	<input checked="" type="checkbox"/> Further documents are listed in the continuation of Box C. <input type="checkbox"/> See patent family annex.	
	* Special categories of cited documents:	"T" later document published after the international filing date or priority date and not in conflict with the application but cited to understand the principle or theory underlying the invention
	"A" document defining the general state of the art which is not considered to be of particular relevance	"X" document of particular relevance; the claimed invention cannot be considered novel or cannot be considered to involve an inventive step when the document is taken alone
	"E" earlier application or patent but published on or after the international filing date	"Y" document of particular relevance; the claimed invention cannot be considered to involve an inventive step when the document is combined with one or more other such documents, such combination being obvious to a person skilled in the art
	"L" document which may throw doubts on priority claim(s) or which is cited to establish the publication date of another citation or other special reason (as specified)	"&" document member of the same patent family
	"O" document referring to an oral disclosure, use, exhibition or other means	
	"P" document published prior to the international filing date but later than the priority date claimed	
	Date of the actual completion of the international search 14 July 2017 (14.07.17)	Date of mailing of the international search report 01 August 2017 (01.08.17)
	Name and mailing address of the ISA/ Japan Patent Office 3-4-3, Kasumigaseki, Chiyoda-ku, Tokyo 100-8915, Japan	Authorized officer Telephone No.

Form PCT/ISA/210 (second sheet) (January 2015)

INTERNATIONAL SEARCH REPORT

International application No.

PCT/JP2017/018542

5

C (Continuation). DOCUMENTS CONSIDERED TO BE RELEVANT

10

15

20

25

30

35

40

45

50

55

Category*	Citation of document, with indication, where appropriate, of the relevant passages	Relevant to claim No.
A	JP 2012-65717 A (Kabushiki Kaisha Real Design), 05 April 2012 (05.04.2012), entire text; all drawings (Family: none)	1-7
A	JP 2013-215252 A (Tanita Corp.), 24 October 2013 (24.10.2013), entire text; all drawings (Family: none)	1-7
A	JP 2008-295644 A (Aisin Seiki Co., Ltd.), 11 December 2008 (11.12.2008), entire text; all drawings (Family: none)	1-7
A	JP 2008-93198 A (Aisin Seiki Co., Ltd.), 24 April 2008 (24.04.2008), entire text; all drawings (Family: none)	1-7

Form PCT/ISA/210 (continuation of second sheet) (January 2015)

INTERNATIONAL SEARCH REPORT

International application No.
PCT/JP2017/018542

5
10
15
20
25
30
35
40
45
50
55

Box No. II Observations where certain claims were found unsearchable (Continuation of item 2 of first sheet)

This international search report has not been established in respect of certain claims under Article 17(2)(a) for the following reasons:

1. Claims Nos.:
because they relate to subject matter not required to be searched by this Authority, namely:

2. Claims Nos.:
because they relate to parts of the international application that do not comply with the prescribed requirements to such an extent that no meaningful international search can be carried out, specifically:

3. Claims Nos.:
because they are dependent claims and are not drafted in accordance with the second and third sentences of Rule 6.4(a).

Box No. III Observations where unity of invention is lacking (Continuation of item 3 of first sheet)

This International Searching Authority found multiple inventions in this international application, as follows:
(Invention 1) claims 1-3
Claims 1 to 3 have the special technical feature of "a biological information monitoring system comprising a signal separation unit which determines the number of subjects on a bed on the basis of a frequency spectrum of a load signal output from each load detector, and which separates, from the load signal output from each load detector, a component corresponding to each of a plurality of frequency bands for each subject". Accordingly, the claims are classified into Invention 1.

- (Invention 2) claims 4-7
(Continued to extra sheet)
1. As all required additional search fees were timely paid by the applicant, this international search report covers all searchable claims.
 2. As all searchable claims could be searched without effort justifying additional fees, this Authority did not invite payment of additional fees.
 3. As only some of the required additional search fees were timely paid by the applicant, this international search report covers only those claims for which fees were paid, specifically claims Nos.:

 4. No required additional search fees were timely paid by the applicant. Consequently, this international search report is restricted to the invention first mentioned in the claims; it is covered by claims Nos.:
- Remark on Protest**
- The additional search fees were accompanied by the applicant's protest and, where applicable, the payment of a protest fee.
 - The additional search fees were accompanied by the applicant's protest but the applicable protest fee was not paid within the time limit specified in the invitation.
 - No protest accompanied the payment of additional search fees.

INTERNATIONAL SEARCH REPORT

International application No.

PCT/JP2017/018542

Continuation of Box No.III of continuation of first sheet(2)

5
10
15
20
25
30
35
40
45
50
55

Claims 4 to 7 have the common technical feature with claim 1 classified into Invention 1 of "a biological information monitoring system for monitoring various biological information of a subject on a bed, the biological information monitoring system comprising a plurality of load detectors which are disposed on the bed or under a leg of the bed to detect and output a load of the subject as a load signal; and a signal separation unit which separates, from the load signal output from each of the load detectors, a component corresponding to each of a plurality of frequency bands".

However, the above-said technical feature cannot be considered to be a special technical feature, since the technical feature does not make a contribution over the prior art in the light of the contents disclosed in WO 2015/078937 A1.

Further, there is no other same or corresponding special technical feature between these inventions.

In addition, claims 4-7 are not dependent on claim 1.

Further, claims 4-7 have no relationship such that these claims are substantially same as or equivalent to any claim classified into Invention 1.

Consequently, claims 4-7 cannot be classified into Invention 1.

Claims 4 to 7 have the special technical feature of "a biological information monitoring system comprising a signal separation unit which separates, from the load signal output from each of the load detectors, a component corresponding to each of a plurality of frequency bands; and a center of gravity position calculation unit which calculates the center of gravity position of the subject on the basis of the separated component". Accordingly, the claims are classified into Invention 2.

REFERENCES CITED IN THE DESCRIPTION

This list of references cited by the applicant is for the reader's convenience only. It does not form part of the European patent document. Even though great care has been taken in compiling the references, errors or omissions cannot be excluded and the EPO disclaims all liability in this regard.

Patent documents cited in the description

- JP 4883380 B [0004]
- JP 61024010 A [0004]
- JP 4829020 B [0018]
- JP 4002905 B [0018]

专利名称(译)	生物信息监测系统		
公开(公告)号	EP3459454A1	公开(公告)日	2019-03-27
申请号	EP2017799433	申请日	2017-05-17
[标]申请(专利权)人(译)	美蓓亚株式会社		
申请(专利权)人(译)	美蓓亚三美公司		
当前申请(专利权)人(译)	美蓓亚三美公司		
[标]发明人	AKATSU HIROYUKI IIDA NORIHITO		
发明人	AKATSU, HIROYUKI IIDA, NORIHITO		
IPC分类号	A61B5/11 A61B5/00 A61B5/0245 A61B5/08 A61B5/113 A61G7/05 G08B21/06 G08B21/22		
CPC分类号	A61B5/0245 A61B5/08 A61B5/113 A61B5/6887 A61G7/05 G08B21/06 G08B21/22 A61B5/0205 A61B5/024 A61B5/1036 A61B5/1102 A61B5/1115 A61B5/6892 A61B2562/0252 A61B2562/046		
优先权	2016101356 2016-05-20 JP		
其他公开文献	EP3459454A4		
外部链接	Espacenet		

摘要(译)

一种生物信息监测系统 (100) ， 用于监测床 (BD) 上的受试者 (S) 的各种生物信息，该系统包括：多个负载检测器 (11,12,13,14) ，放置在床上或者在床的腿下，多个负载检测器中的每一个被配置为检测对象的负载并输出检测到的负载作为负载信号;信号分离单元 (32) ，被配置为从每个负载检测器输出的负载信号中分离每个对应于多个频率范围内的每一个的组件;和重心位置计算单元 (33) ，被配置为基于分离的分量计算对象的重心位置。

