



(11) **EP 3 188 648 B1**

(12) **EUROPEAN PATENT SPECIFICATION**

(45) Date of publication and mention of the grant of the patent:  
**01.01.2020 Bulletin 2020/01**

(51) Int Cl.:  
**A61B 5/00** <sup>(2006.01)</sup> **A01K 11/00** <sup>(2006.01)</sup>  
**A01K 29/00** <sup>(2006.01)</sup>

(21) Application number: **15857279.2**

(86) International application number:  
**PCT/US2015/059292**

(22) Date of filing: **05.11.2015**

(87) International publication number:  
**WO 2016/073754 (12.05.2016 Gazette 2016/19)**

(54) **COMPANION ANIMAL HEALTH MONITORING SYSTEM**

**HAUSTIERGESUNDHEITSÜBERWACHUNGSSYSTEM**

**SYSTÈME DE SURVEILLANCE DE LA SANTÉ D'UN ANIMAL DE COMPAGNIE**

(84) Designated Contracting States:  
**AL AT BE BG CH CY CZ DE DK EE ES FI FR GB GR HR HU IE IS IT LI LT LU LV MC MK MT NL NO PL PT RO RS SE SI SK SM TR**

- **DE MEULEMEESTER, Johan**  
**9840 De Pinte (BE)**
- **BOLTON, Brian**  
**DFW Airport, TX 75261 (US)**

(30) Priority: **05.11.2014 US 201462075745 P**  
**04.11.2015 US 201514932212**

(74) Representative: **Vidon Brevets & Stratégie**  
**16B, rue de Jouanet**  
**BP 90333**  
**35703 Rennes Cedex 7 (FR)**

(43) Date of publication of application:  
**12.07.2017 Bulletin 2017/28**

(73) Proprietor: **Allflex USA, Inc.**  
**DFW Airport, TX 75261 (US)**

(56) References cited:  
**WO-A1-2005/104930 FR-A1- 2 801 491**  
**GB-A- 2 437 250 US-A1- 2002 010 390**  
**US-A1- 2002 010 390 US-A1- 2006 202 818**  
**US-A1- 2011 001 610 US-A1- 2012 299 731**  
**US-B2- 8 219 053**

(72) Inventors:

- **STEWART, Robert**  
**Mancos, CO 81328 (US)**
- **HILL, Nicholas**  
**DFW Airport, TX 75261 (US)**

**EP 3 188 648 B1**

Note: Within nine months of the publication of the mention of the grant of the European patent in the European Patent Bulletin, any person may give notice to the European Patent Office of opposition to that patent, in accordance with the Implementing Regulations. Notice of opposition shall not be deemed to have been filed until the opposition fee has been paid. (Art. 99(1) European Patent Convention).

## Description

### FIELD OF INVENTION

**[0001]** This invention relates to the use of radio frequency identification and specifically to short range radio frequency communications applied to the remote monitoring of animal physiological data for the purpose of assessing animal health and welfare.

### BACKGROUND

**[0002]** Radio Frequency Identification (RFID) is an established technology that has been deployed in animal identification applications for nearly three decades. While initially promoted as a lost animal retrieval means, RFID has more recently been promoted as a means of identification associated with animal health insurance products. More recent advances in microchip technology have resulted in the inclusion of physiological sensors, such as a temperature sensor, in the transponder. Typical of such a device is the Destron BioThermo® transponder, manufactured by Destron-Fearing Corporation of Eagan, MN.

It is known to measure the condition of an animal using at least one sensor, for example a temperature sensor in an implantable device, and to transmit such information to a remote device.

For example, WO 2005/104930 discloses a remote animal health and location monitoring system including an implantable monitoring device. US 2002/0010390 discloses a method and system for automated monitoring and early warning of changes in parameters related to the health and status of animals. GB 2437250 discloses a method and system for monitoring the condition of livestock, and comprises a plurality of sensors for sensing a plurality of different parameters of an animal. FR 2801491 discloses a system and method for monitoring physiological parameter of an animal.

### SUMMARY OF THE INVENTION

**[0003]** The invention consists in a system for companion animal health monitoring according to claim 1.

**[0004]** In an embodiment of the invention, the power source includes a battery.

**[0005]** In an additional embodiment of the invention, the electronic assembly transmits the identification data and the temperature data to a cellular telephone.

**[0006]** In yet another additional embodiment of the invention, the electronic assembly transmits the identification data and the temperature data in response to a request received from the cellular telephone.

**[0007]** In still another additional embodiment of the invention, the electronic assembly transmits the identification data and the temperature data based on a pre-determined schedule.

**[0008]** In yet still another additional embodiment of the

invention, the electronic assembly further includes an RFID transceiver and the electronic assembly interrogates the microchip using the RFID transceiver.

**[0009]** In yet another embodiment of the invention, the electronic assembly dynamically adjusts a resonance capacitance of an antenna based on a frequency for interrogating the microchip using the RFID transceiver.

**[0010]** In still another embodiment of the invention, the electronic assembly further includes a memory and the electronic assembly stores the obtained data using the memory.

**[0011]** In yet still another embodiment of the invention, the electronic assembly further includes a real time clock capable of determining time data.

**[0012]** In yet another additional embodiment of the invention, the electronic assembly further obtains time data using the real time clock and transmits the time data.

**[0013]** In still another additional embodiment of the invention, the electronic assembly further transmits the data based on the time data obtained using the real time clock.

**[0014]** In yet still another additional embodiment of the invention, the electronic assembly is integrated into a collar worn by the animal.

**[0015]** In yet another embodiment of the invention, the electronic assembly further includes a Global Positioning System (GPS) receiver capable of generating location data and the electronic assembly further transmits the location data.

**[0016]** In still another embodiment of the invention, the electronic assembly further includes an environmental temperature sensor and the electronic assembly further obtains environmental temperature data using the environmental temperature sensor and transmits the environmental temperature data.

**[0017]** In yet still another embodiment of the invention, the electronic assembly is further connected to an antenna.

**[0018]** According to the invention, the antenna is integrated into a collar worn by the companion animal and the electronic assembly includes a connector that connects to the antenna.

**[0019]** In still another additional embodiment of the invention, the antenna includes a ferrite core solenoid-form antenna.

**[0020]** In yet still another additional embodiment of the invention, the microchip is implanted in the animal such that it is located within a threshold distance from the antenna when the collar is fitted on the companion animal.

**[0021]** In yet another embodiment of the invention, the electronic assembly transmits the data using a Bluetooth connection.

**[0022]** In still another embodiment of the invention, the electronic assembly transmits the data using a cellular connection.

## BRIEF DESCRIPTION OF THE DRAWINGS

**[0023]**

FIG. 1 is a conceptual illustration of a typical companion animal exemplar in accordance with an embodiment of the invention.

FIG. 2 is a conceptual illustration of the content of the electronic assembly in accordance with an embodiment of the invention.

FIG. 3 is a flowchart illustrating a process for reading and transmitting data in accordance with an embodiment of the invention.

FIG. 4 is a conceptual illustration of a collar in accordance with an embodiment of the invention.

## DETAILED DESCRIPTION OF THE INVENTION

**[0024]** Turning now to the drawings, systems and methods for companion animal health monitoring are disclosed. Such companion animal identification systems can include a small glass encapsulated passive transponder ("microchip"), typically measuring 12mm long by 2mm in diameter, that is easily and quickly implanted using a hollow point needle. The microchip can be activated and scanned for its internally stored unique identification code by a reader device. The temperature sensing microchip is physically identical to a conventional identification microchip and can include a temperature sensor. The microchips can transmit identification and temperature data when activated, either automatically or in response to a scan tool utilized to read the microchip. Identification and temperature scanning is useful to animal healthcare specialists and can also be informative to pet owners as a means to monitor animal health and welfare.

Companion Animal Health Monitoring Systems

**[0025]** FIG. 1 illustrates a typical companion animal exemplar, which for the purposes of describing the present invention is a canine 101, hereinafter referred to as "Roscoe". Roscoe possesses a temperature sensing microchip 102 injected within his body, preferably at a location that is medial to his scapulae (shoulder blades), and well into subcutaneous tissue where it will resist migration. Roscoe also possesses a collar 103 which can be equipped with a microchip scanner for the purpose of periodically capturing identification and temperature data from the microchip. Specifically, there can be mounted on the collar 103 a scanning antenna 105 and an electronic assembly 104 which together constitute the microchip scanner. While antenna 105 and electronic assembly 104 could be attached to a conventional dog collar, a custom collar into which this cable is integrally structured, and is thereby protected, is preferred. For example, the cable can be sewn and/or molded into the material of the collar. However, any variety of construction

for connecting the antenna and electronic assembly, including wireless connections, can be utilized as appropriate to the requirements of specific applications of embodiments of the invention. Antenna 105 can be constructed as a loop antenna including a multitude of turns of an electrical conductor embedded circumferentially in the dog collar 103. An antenna of this type can include an electrical connector (not shown) that permits the collar to be separated and joined for attachment purposes. In several embodiments, the electronic assembly 104 includes a transformer (not shown) that can be used to connect to the antenna 105. In this way, a simple connector can be utilized to connect to the antenna. In a number of embodiments, the electronic assembly 104 is inductively coupled to the antenna 105. This arrangement can permit the collar and electronic assembly to be separate physical packages so that a single electronic assembly could be paired with any of several alternate collar sizes or designs. A preferred embodiment for antenna 105 includes a ferrite core solenoid-form antenna located at the top of the collar 103 nearby the implanted microchip 102. The physical weight of the electronic assembly 104 can maintain the antenna's position near microchip 102. In many embodiments, the electronic assembly 104 is attached to the collar 103 via any of a variety of connectors, such as buttons, snaps, hook-and-loop fasteners, or any other connector as appropriate to the requirements of specific applications of embodiments of the invention. In a number of embodiments, the collar 103 includes a strain-relief device that can be utilized to reduce the strain on the antenna.

**[0026]** In several embodiments, the collar 103 is designed to automatically resize itself to the size of the companion animal. The collar can be manufactured from an elastic material and/or include a reel for drawing up excess collar material as appropriate to the requirements of specific applications of embodiments of the invention. Additionally, harnesses are often more stable than collars and tend to be located between the head and just behind the front legs of the companion animal. In a variety of embodiments, the collar 103 is a harness that includes a variety of straps, bands, and/or other panels of material that can be attached to secure the harness to Roscoe. The electronic assembly 104 can then be attached anywhere on the harness, including locations that are closer to the implanted microchip than are possible with a standard collar.

**[0027]** Turning now to FIG. 4, a conceptual illustration of a collar that can be worn by a companion animal is shown. The collar assembly 400 includes a collar strap 401. In a variety of embodiments, the collar strap 401 contains an embedded antenna. Electronic assembly 402 can be attached to the collar strap and includes a receptacle 404. The collar strap further includes a connector plug 403, connected to the embedded antenna, which can be mated with the receptacle 404 to connect the embedded antenna to the electronic assembly. The antenna, connector plug, and/or receptacle can be sin-

gle-conductor and/or multi-conductor as appropriate to the requirements of specific applications of embodiments of the invention. Further, the connection between the connector plug and receptacle can be direct and/or wireless, such as an inductive connection, as appropriate to the requirements of specific applications of embodiments of the invention. In many embodiments, the receptacle 404 includes multi-pole connector to that, when connected to the connector plug 403, completes a multi-turn antenna embedded in the collar strap 401.

**[0028]** Returning to FIG. 1, electronic assembly 104 can be contained within a hermetically sealed enclosure containing components and circuitry that perform functions to be described in detail to follow. The electronic assembly 104 can periodically self-activates, captures identification and temperature data from the microchip 102, and conveys this information wirelessly 107 to a nearby device such a smartphone 106 equipped with a compatible wireless radio and a user application. The self-activation time period can be pre-determined and/or determined dynamically as appropriate to the requirements of specific applications of embodiments of the invention. Wireless connectivity 107 between the electronic assembly 104 and smartphone device 106 preferably include a Bluetooth technology short range radio, but could alternately include a Wi-Fi connection, a near-field communication (NFC) radio, a cellular telephone connection, (SMS, e.g., "text message") or any of several other wireless radio options that are known to those familiar in the art. Additionally, it should be noted that a variety of embodiments include a wired connection for transmitting data using the electronic assembly.

**[0029]** Although specific examples of companion animal health monitoring systems are described with respect to FIG. 1 and collars with respect to FIG. 4, any of a variety of systems, including those that are utilized with animals other than dogs and those that utilize alternative sensors for determining biometric data regarding the animal, can be utilized in accordance with embodiments of the invention.

#### Electronic Assemblies

**[0030]** Turning now to FIG. 2, a conceptual illustration of the content of an electronic assembly 201 is shown. This electronic assembly 201 can powered from battery 203, and is designed to remain predominantly in a very low power consuming dormant state except when scanning the microchip 202 and when transmitting identification and temperature data. However, it should be noted that any power source, including capacitors and energy harvesting devices, can be utilized as appropriate to the requirements of specific applications of embodiments of the invention. Any form of energy harvesting device, such as devices that generate energy based on the movement of the companion animal, the collar, solar power, heat generated by the animal, inductive charging coils, and any other energy source can be utilized as appropriate

to the requirements of specific applications of embodiments of the invention. In particular, inductive charging coils can be included in a hermetically-sealed housing containing the electronic assembly 201. These hermetically-sealed housings can be advantageous in a variety of environments, such as a shelter where the electronic assembly 201 is utilized on a variety of animals. In a variety of embodiments, the inductive charging coils include the RF antenna 204, although the inductive charging coils can include a separate antenna as appropriate to the requirements of specific applications of embodiments of the invention. Additionally, the energy-harvesting devices can be located external to the electronic assembly 201, such as on the collar of the companion animal, and connected to the electronic assembly via wired and/or wireless connections as appropriate to the requirements of specific applications of embodiments of the invention.

**[0031]** Microcontroller 206 can be programmed (e.g. with firmware code) that supervises the functions and behavior of the electronic assembly 201. These functions include measuring and/or recording a variety of data using any of a variety of sensors and devices, including but not limited to real time clock/calendar (RTCC) 210, environmental temperature sensor 209, memory 207, radio frequency (RF) transceiver 208, RF antenna 204, and RFID transceiver 211. Microcontroller 206 can be programmed using a number of devices, such as scanning tools and smartphones executing a user application, to scan microchip 202 for data at periodic intervals, such as once per hour, every five minutes, twice daily, or any interval of user interest. Microcontroller 206 can emerge from its normally dormant state and executes the functions pertinent to data reporting on demand and/or during the defined intervals as appropriate to the requirements of specific applications of embodiments of the invention.

**[0032]** A process for measuring and providing data using the electronic assembly is shown in FIG. 3. The process 300 includes activating (310) an electronic assembly, reading (312) microchip data, and in many embodiments storing (314) data. Data is transmitted (316) and, in several embodiments, the electronic assembly and/or microchip enters (318) a low power state. However, any of a variety of processes can be utilized to obtain and transmit data regarding the animal as appropriate to the requirements of specific applications of embodiments of the invention.

**[0033]** For example, upon wakeup, the microcontroller 206 activates RFID transceiver 211 which sends an activation signal to RFID antenna 205 via connecting cable 213. This activation signal causes RFID antenna 205 to emit a magnetic field 212 which in turn inductively powers microchip 202. In several embodiments, the operating frequency for the microchip 202 is between 120 KHz and 150 KHz, with 134.2 KHz being commonly utilized, although any frequency can be utilized as appropriate to the requirements of specific applications of embodiments of the invention. In many embodiments, the microcon-

troller automatically identifies a frequency for communication with the microchip utilizing any of a variety of RFID automatic tuning techniques as appropriate to the requirements of specific applications of embodiments of the invention. In a number of embodiments, automatic frequency identification can be performed by supplying power to the microcontroller reading the microchip, monitoring the power supplied, storing data related to the monitored power supplied, emitting a signal from an antenna, filtering the harmonic of such signal, outputting the phase signal to a processor and adjusting capacitors based on the phase signal and monitored current. A variety of automatic tuning readers that can be utilized in accordance with embodiments of the invention are disclosed in U.S. Patent No. 8,219,053, titled "Automatic Tuning Reader" and issued July 10, 2012, the disclosure of which is hereby incorporated by reference in its entirety. In several embodiments, the reading frequency (i.e. excitation frequency) of the microchip 202 is fixed and the microcontroller 206 adjusts the resonance capacitance based on the antenna inductance which depends on the geometry of the collar at the precise moment of reading the microchip 202. In a variety of embodiments, the microcontroller monitors the antenna inductance and/or the deviation from resonance of the antenna and adjusts tuning capacitors to bring the antenna closer to resonance frequency, thereby improving the reading distance and reading reliability of the microchip 202. In many embodiments, the electronic assembly switches capacitors are in and out of the antenna circuit to optimize the tuning to resonance based on an assessment of the microchip signal's phase, amplitude, or power consumption.

**[0034]** Microchip 202 returns a signal to the microcontroller via RFID antenna 205, connecting cable 213, and RFID transceiver 211, where the signal includes identification and/or temperature data. Microcontroller 206 creates a data record consisting of the identification and temperature data acquired from microchip 202, current time and date information acquired from RTCC 210, and local environmental temperature data acquired from temperature sensor 209, and stores this composite data record in memory 207. Microcontroller 206 then activates RF transmitter 208 and establishes a connection with a remote device (e.g. a smartphone or scan tool) using RF antenna 204. Once this connection is established, microcontroller 206 transmits captured data stored in memory 207. Other stored data that are not indicated as having been previously transmitted can also be sent as appropriate to the requirements of specific applications of embodiments of the invention. Once data record conveyance has occurred and confirmed, microcontroller 206 places the electronic assembly 201 in a low power dormant state, and awaits countdown to the next activation event. It should be noted that the data can be transmitted to any device, such as a base station or data server system, as appropriate to the requirements of specific applications of embodiments of the invention.

**[0035]** By capturing and conveying data records that include identification and temperature data, multiple animals can be tracked and monitored. The time/date and environmental temperature data sent from electronic assembly 201 can be used to develop temperature profiles via user application algorithms that in turn provide alerts to the pet owner when the animal temperature deviates from a normal or user specified temperature range. In many embodiments, this data can be transmitted to a base station located in an automobile and describes the condition of the companion animal while left in the vehicle. This can allow for alerts to be generated if the conditions in the vehicle pose a risk to the companion animal, such as overheating in the summer and hypothermia in the winter.

**[0036]** Electronic assembly 201 can further be equipped with additional physiological sensors that could, for example, provide indications of other animal characteristics and behavior, such as pulse rate and activity (motion). Such physiological sensors could also be integrated into microchip 202 and the appropriate data obtained from the microchip. Additionally, electronic assembly 201 can be packaged in combination with other electronic functions such as a training collar that provides guidance to the animal in response to input obtained from a remote control, a Global Positioning System (GPS) tracking locator radio providing location data regarding the location of the animal, and any other electronic function as appropriate to the requirements of specific applications of embodiments of the invention. In many embodiments, the electronic assembly can include a radio-frequency transceiver, such as a Bluetooth transceiver, that can communicate with location beacons, such as, but not limited to, Bluetooth Low Energy beacons. When the electronic assembly is within range of the location beacon, the appropriate data for the location beacon (such as a beacon identifier, time data, and/or another data as appropriate to the requirements of specific applications of embodiments of the invention) can be received using the radio frequency transceiver and utilized to determine the location of the electronic assembly 201.

**[0037]** In a variety of embodiments, these sensors can be located external to the electronic assembly 201 and communicate with the electronic assembly 201 via wired and/or wireless means. For example, a companion animal activity sensor can be utilized to measure the activity of the companion animal and the measured activity data can be transmitted to the electronic assembly 201. The activity data can include, distance traveled, direction information, barking activity (or other appropriate noise-based measurements of the companion animal), time at rest, heart rate, and any other data as appropriate to the requirements of specific applications of embodiments of the invention.

**[0038]** Although specific examples of electronic assemblies are described with respect to FIG. 2, any of a variety of systems, including those utilizing additional sensors for determining biometric data regarding the an-

imal, can be utilized in accordance with embodiments of the invention.

**[0039]** Although the present invention has been described in certain specific aspects, many additional modifications and variations would be apparent to those skilled in the art. In particular, any of the various processes described above can be performed in alternative sequences and/or in parallel (on the same or on different computing devices) in order to achieve similar results in a manner that is more appropriate to the requirements of a specific application. It is therefore to be understood that the present invention can be practiced otherwise than specifically described without departing from the scope of the present invention as defined by the claims. Thus, embodiments of the present invention should be considered in all respects as illustrative and not restrictive. Accordingly, the scope of the invention should be determined not by the embodiments illustrated, but by the appended claims.

## Claims

### 1. An animal health monitoring system, comprising:

an electronic assembly (104; 201; 402) designed to be located on a companion animal, comprising:

a microprocessor (206);  
a power source connected to the microprocessor; and  
a transceiver (208);

a microchip (202) designed to be implanted in the companion animal and comprising:

memory storing identification data; and  
a temperature sensor measuring the temperature of the companion animal;

wherein said system also comprises:

a collar (103) designed to be worn by the companion animal,  
an antenna (105; 205) integrated into the collar,

wherein the electronic assembly and the antenna constitute a microchip scanner, wherein the electronic assembly (201) is configured to:

interrogate the microchip (202) to obtain identification data and temperature data from the microchip (202); and  
transmit the identification data and the temperature data, **characterised in that:**

the antenna (105; 205) is a loop antenna embedded circumferentially in the collar, and

wherein the reading frequency of the microchip (202) is fixed and the microprocessor (206) is configured to adjust the resonance capacitance based on the antenna inductance which depends on the geometry of the collar at the precise moment of reading the microchip (202).

2. The animal health monitoring system of claim 1, wherein the power source comprises a battery (203).

3. The animal health monitoring system of claim 1, wherein the electronic assembly transmits the identification data and the temperature data to a cellular telephone.

4. The animal health monitoring system of claim 3, wherein the electronic assembly transmits the identification data and the temperature data in response to a request received from the cellular telephone.

5. The animal health monitoring system of claim 3, wherein the electronic assembly transmits the identification data and the temperature data based on a pre-determined schedule.

6. The animal health monitoring system of claim 1, wherein:

the electronic assembly further comprises an RFID transceiver (211); and  
the electronic assembly interrogates the microchip using the RFID transceiver (211).

7. The animal health monitoring system of claim 6, wherein the electronic assembly further dynamically adjusts a resonance capacitance of an antenna based on a frequency for interrogating the microchip using the RFID transceiver.

8. The animal health monitoring system of claim 1, wherein:

the electronic assembly further comprises a memory (207); and  
the electronic assembly stores the obtained data using the memory (207).

9. The animal health monitoring system of claim 1, wherein the electronic assembly further comprises a real time clock (210) capable of determining time data.

10. The animal health monitoring system of claim 9, wherein the electronic assembly further:

- obtains time data using the real time clock; and transmits the time data.
11. The animal health monitoring system of claim 9, wherein the electronic assembly further transmits the data based on the time data obtained using the real time clock.
12. The animal health monitoring system of claim 1, wherein the electronic assembly is integrated into the collar (103) worn by the animal.
13. The animal health monitoring system of claim 1, wherein:
- the electronic assembly further comprises a Global Positioning System (GPS) receiver capable of generating location data; and the electronic assembly further transmits the location data.
14. The animal health monitoring system of claim 1, wherein:
- the electronic assembly further comprises an environmental temperature sensor (209); and the electronic assembly further:
- obtains environmental temperature data using the environmental temperature sensor; and transmits the environmental temperature data.
15. The animal health monitoring system of claim 1, wherein the antenna comprises a ferrite core solenoid-form antenna.
16. The animal health monitoring system of claim 1, wherein the microchip is implanted in the animal such that it is located within a threshold distance from the antenna when the collar is fitted on the companion animal.
17. The animal health monitoring system of claim 1, wherein the electronic assembly transmits the data using a Bluetooth connection.
18. The animal health monitoring system of claim 1, wherein the electronic assembly transmits the data using a cellular connection.
19. The animal health monitoring system of claim 1, wherein the electronic assembly further comprises an RF antenna (204) connected to the transceiver (208).
20. The animal health monitoring system of claim 1,

wherein said system also comprises a connector (403) designed to connect the electronic assembly to the antenna (105; 205).

## Patentansprüche

1. Tiergesundheitsüberwachungssystem umfassend:
- eine elektronische Anordnung (104; 201; 402), die gestaltet ist, an einem Haustier angeordnet zu werden, umfassend:
- einen Mikroprozessor (206);  
eine Energiequelle, die mit dem Mikroprozessor verbunden ist; und  
einen Transceiver (208);
- einen Mikrochip (202), der gestaltet ist, um in das Haustier implantiert zu werden und umfasst:
- einen Speicher, der Identifikationsdaten speichert; und  
einen Temperatursensor, der die Temperatur des Haustiers misst;
- wobei das System auch umfasst:
- ein Halsband (103), das gestaltet ist, von einem Haustier getragen zu werden,  
eine Antenne (105; 205), die in das Halsband integriert ist,
- wobei die elektronische Anordnung und die Antenne einen Mikrochipscanner bilden, wobei die elektronische Anordnung (201) eingerichtet ist zum:
- Abfragen des Mikrochips (202) zum Erhalten von Identifikationsdaten und Temperaturdaten vom Mikrochip (202); und  
Übertragen der Identifikationsdaten und der Temperaturdaten, charakterisiert dadurch, dass:
- die Antenne (105; 205) eine Schleifenantenne ist, die in Umfangsrichtung in das Halsband eingebettet ist, und  
wobei die Lesefrequenz des Mikrochips (202) fest ist und der Mikroprozessor (206) eingerichtet ist, die Resonanzkapazität basierend auf der Antenneninduktivität einzustellen, die von der Geometrie des Halsbands zum präzisen Moment des Auslesens des Mikrochips (202) abhängig ist.
2. Tiergesundheitsüberwachungssystem nach Anspruch 1, wobei die Energiequelle eine Batterie (203)

- umfasst.
3. Tiergesundheitsüberwachungssystem nach Anspruch 1, wobei die elektronische Anordnung die Identifikationsdaten und die Temperaturdaten an ein Mobiltelefon überträgt. 5
4. Tiergesundheitsüberwachungssystem nach Anspruch 3, wobei die elektronische Anordnung die Identifikationsdaten und die Temperaturdaten als Reaktion auf eine vom Mobiltelefon empfangene Anfrage überträgt. 10
5. Tiergesundheitsüberwachungssystem nach Anspruch 3, wobei die elektronische Anordnung die Identifikationsdaten und die Temperaturdaten basierend auf einem vorbestimmten Zeitplan sendet. 15
6. Tiergesundheitsüberwachungssystem nach Anspruch 1, wobei: 20  
 die elektronische Anordnung ferner einen RFID-Transceiver (211) umfasst; und  
 die elektronische Anordnung den Mikrochip unter Verwendung des RFID-Transceivers (211) abfragt. 25
7. Tiergesundheitsüberwachungssystem nach Anspruch 6, wobei die elektronische Anordnung ferner eine Resonanzkapazität einer Antenne basierend auf einer Frequenz zum Abfragen des Mikrochips unter Verwendung des RFID-Transceivers dynamisch anpasst. 30
8. Tiergesundheitsüberwachungssystem nach Anspruch 1, wobei: 35  
 die elektronische Anordnung ferner einen Speicher (207) umfasst; und  
 die elektronische Anordnung die erhaltenen Daten unter Verwendung des Speichers (207) speichert. 40
9. Tiergesundheitsüberwachungssystem nach Anspruch 1, wobei die elektronische Anordnung ferner eine Echtzeituhr (210) umfasst, die in der Lage ist, Zeitdaten zu bestimmen. 45
10. Tiergesundheitsüberwachungssystem nach Anspruch 9, wobei die elektronische Anordnung ferner: 50  
 Zeitdaten unter Verwendung der Echtzeituhr erlangt; und  
 die Zeitdaten überträgt.
11. Tiergesundheitsüberwachungssystem nach Anspruch 9, wobei die elektronische Anordnung ferner die Daten basierend auf den Zeitdaten, die unter Verwendung der Echtzeituhr erlangt wurden, überträgt.
12. Tiergesundheitsüberwachungssystem nach Anspruch 1, wobei die elektronische Anordnung in das Halsband (103), das durch das Tier getragen wird, integriert ist.
13. Tiergesundheitsüberwachungssystem nach Anspruch 1, wobei: 10  
 die elektronische Anordnung ferner einen Global Positionierungssystem (GPS)-Empfänger aufweist, der in der Lage ist, Standortdaten zu erzeugen; und  
 die elektronische Anordnung ferner die Standortdaten überträgt.
14. Tiergesundheitsüberwachungssystem nach Anspruch 1, wobei: 20  
 die elektronische Anordnung ferner einen Umgebungstemperatursensor (209) aufweist; und  
 die elektronische Anordnung ferner: 25  
 Umgebungstemperaturdaten unter Verwendung des Umgebungstemperatursensors erlangt; und  
 die Umgebungstemperaturdaten überträgt.
15. Tiergesundheitsüberwachungssystem nach Anspruch 1, wobei die Antenne eine Ferritkernmagnetspulenantenne umfasst.
16. Tiergesundheitsüberwachungssystem nach Anspruch 1, wobei der Mikrochip im Tier so implantiert ist, dass er innerhalb eines Schwellenabstands von der Antenne angeordnet ist, wenn das Halsband am Haustier befestigt ist.
17. Tiergesundheitsüberwachungssystem nach Anspruch 1, wobei die elektronische Anordnung die Daten unter Verwendung einer Bluetoothverbindung überträgt.
18. Tiergesundheitsüberwachungssystem nach Anspruch 1, wobei die elektronische Anordnung die Daten unter Verwendung einer Mobilfunkverbindung überträgt.
19. Tiergesundheitsüberwachungssystem nach Anspruch 1, wobei die elektronische Anordnung ferner eine RF-Antenne (204), die mit dem Transceiver (208) verbunden ist, umfasst.
20. Tiergesundheitsüberwachungssystem nach Anspruch 1, wobei das System einen Verbinder (403) umfasst, der eingerichtet ist, die elektronische Anordnung mit der Antenne (105; 205) zu verbinden.

## Revendications

1. Système de surveillance de la santé d'un animal, comprenant :

un ensemble électronique (104 ; 201 ; 402) conçu pour être situé sur un animal de compagnie, comprenant :

un microprocesseur (206) ;  
une source d'alimentation connectée au microprocesseur ; et  
un émetteur-récepteur (208) ;

une micropuce (202) conçue pour être implantée dans l'animal de compagnie et comprenant :

une mémoire stockant des données d'identification ; et  
un capteur de température mesurant la température de l'animal de compagnie ;

dans lequel ledit système comprend également :

un collier (103) conçu pour être porté par l'animal de compagnie,  
une antenne (105 ; 205) intégrée dans le collier,  
dans lequel l'ensemble électronique et l'antenne constituent un scanner pour micropuce,  
dans lequel l'ensemble électronique (201) est configuré pour :

interroger la micropuce (202) pour obtenir des données d'identification et des données de température à partir de la micropuce (202) ; et  
transmettre les données d'identification et les données de température,  
**caractérisé en ce que :**

l'antenne (105 ; 205) est une antenne cadre incorporée de manière circonférentielle dans le collier, et  
dans lequel la fréquence de lecture de la micropuce (202) est fixée et le microprocesseur (206) est configuré pour ajuster la capacité de résonance sur la base de l'inductance de l'antenne qui dépend de la géométrie du collier au moment précis de la lecture de la micropuce (202).

2. Système de surveillance de la santé d'un animal se-

lon la revendication 1, dans lequel la source d'alimentation comprend une batterie (203).

3. Système de surveillance de la santé d'un animal selon la revendication 1, dans lequel l'ensemble électronique transmet les données d'identification et les données de température à un téléphone cellulaire.

4. Système de surveillance de la santé d'un animal selon la revendication 3, dans lequel l'ensemble électronique transmet les données d'identification et les données de température en réponse à une requête reçue à partir du téléphone cellulaire.

5. Système de surveillance de la santé d'un animal selon la revendication 3, dans lequel l'ensemble électronique transmet les données d'identification et les données de température sur la base d'un calendrier prédéterminé.

6. Système de surveillance de la santé d'un animal selon la revendication 1, dans lequel :

l'ensemble électronique comprend en outre un émetteur-récepteur RFID (211) ; et  
l'ensemble électronique interroge la micropuce en utilisant l'émetteur-récepteur RFID (211).

7. Système de surveillance de la santé d'un animal selon la revendication 6, dans lequel l'ensemble électronique ajuste en outre dynamiquement une capacité de résonance d'une antenne sur la base d'une fréquence pour interroger la micropuce en utilisant l'émetteur-récepteur RFID.

8. Système de surveillance de la santé d'un animal selon la revendication 1, dans lequel :

l'ensemble électronique comprend en outre une mémoire (207) ; et  
l'ensemble électronique stocke les données obtenues en utilisant la mémoire (207).

9. Système de surveillance de la santé d'un animal selon la revendication 1, dans lequel l'ensemble électronique comprend en outre une horloge en temps réel (210) capable de déterminer des données temporelles.

10. Système de surveillance de la santé d'un animal selon la revendication 9, dans lequel l'ensemble électronique en outre :

obtient des données temporelles en utilisant l'horloge en temps réel ; et  
transmet les données temporelles.

11. Système de surveillance de la santé d'un animal se-

- lon la revendication 9, dans lequel l'ensemble électronique transmet en outre les données sur la base des données temporelles obtenues en utilisant l'horloge en temps réel.
- 12.** Système de surveillance de la santé d'un animal selon la revendication 1, dans lequel l'ensemble électronique est intégré dans le collier (103) porté par l'animal. 5
- 13.** Système de surveillance de la santé d'un animal selon la revendication 1, dans lequel :
- l'ensemble électronique comprend en outre un récepteur du système mondial de localisation (GPS) capable de générer des données d'emplacement ; et 15
- l'ensemble électronique transmet en outre les données d'emplacement. 20
- 14.** Système de surveillance de la santé d'un animal selon la revendication 1, dans lequel :
- l'ensemble électronique comprend en outre un capteur de température environnementale (209) ; et 25
- l'ensemble électronique en outre :
- obtient des données de température environnementale en utilisant le capteur de température environnementale ; et 30
- transmet les données de température environnementale.
- 15.** Système de surveillance de la santé d'un animal selon la revendication 1, dans lequel l'antenne comprend une antenne sous forme de solénoïde à noyau de ferrite. 35
- 16.** Système de surveillance de la santé d'un animal selon la revendication 1, dans lequel la micropuce est implantée dans l'animal de telle sorte qu'elle est située dans les limites d'une distance seuil depuis l'antenne lorsque le collier est installé sur l'animal de compagnie. 40
- 17.** Système de surveillance de la santé d'un animal selon la revendication 1, dans lequel l'ensemble électronique transmet les données en utilisant une connexion Bluetooth. 45
- 18.** Système de surveillance de la santé d'un animal selon la revendication 1, dans lequel l'ensemble électronique transmet les données en utilisant une connexion cellulaire. 50
- 19.** Système de surveillance de la santé d'un animal selon la revendication 1, dans lequel l'ensemble élec-
- tronique comprend en outre une antenne RF (204) connectée à l'émetteur-récepteur (208).
- 20.** Système de surveillance de la santé d'un animal selon la revendication 1, dans lequel ledit système comprend également un connecteur (403) conçu pour connecter l'ensemble électronique à l'antenne (105 ; 205). 55

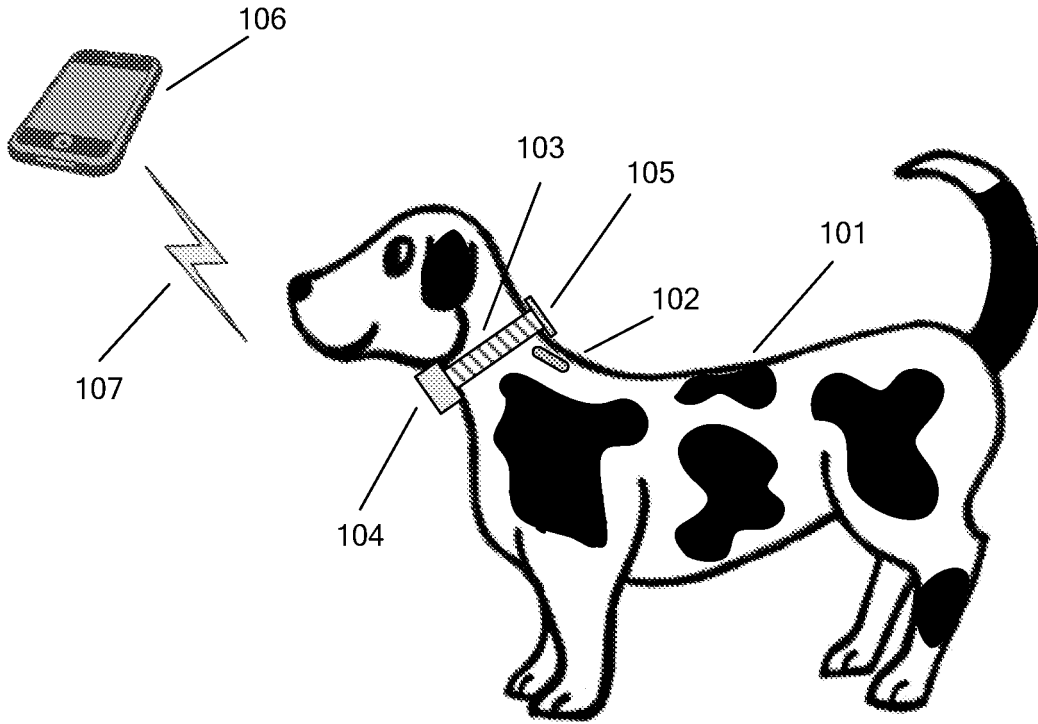

Fig. 1

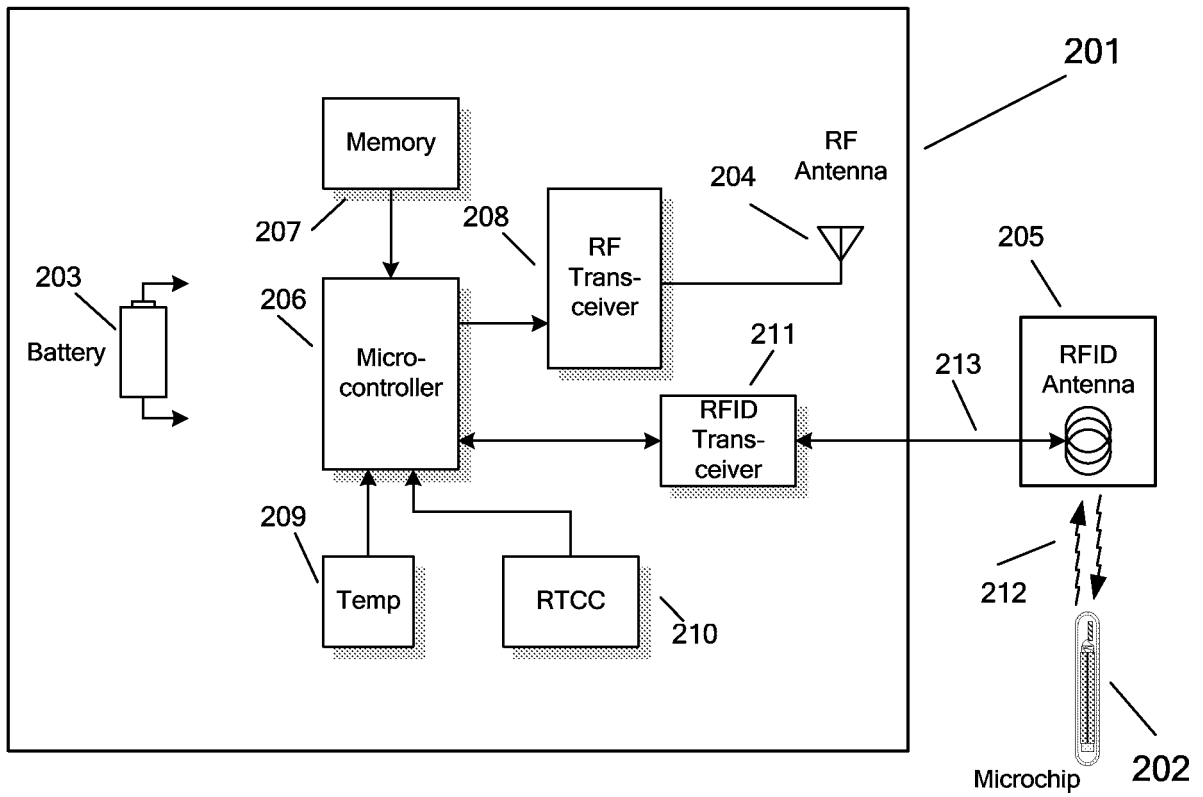
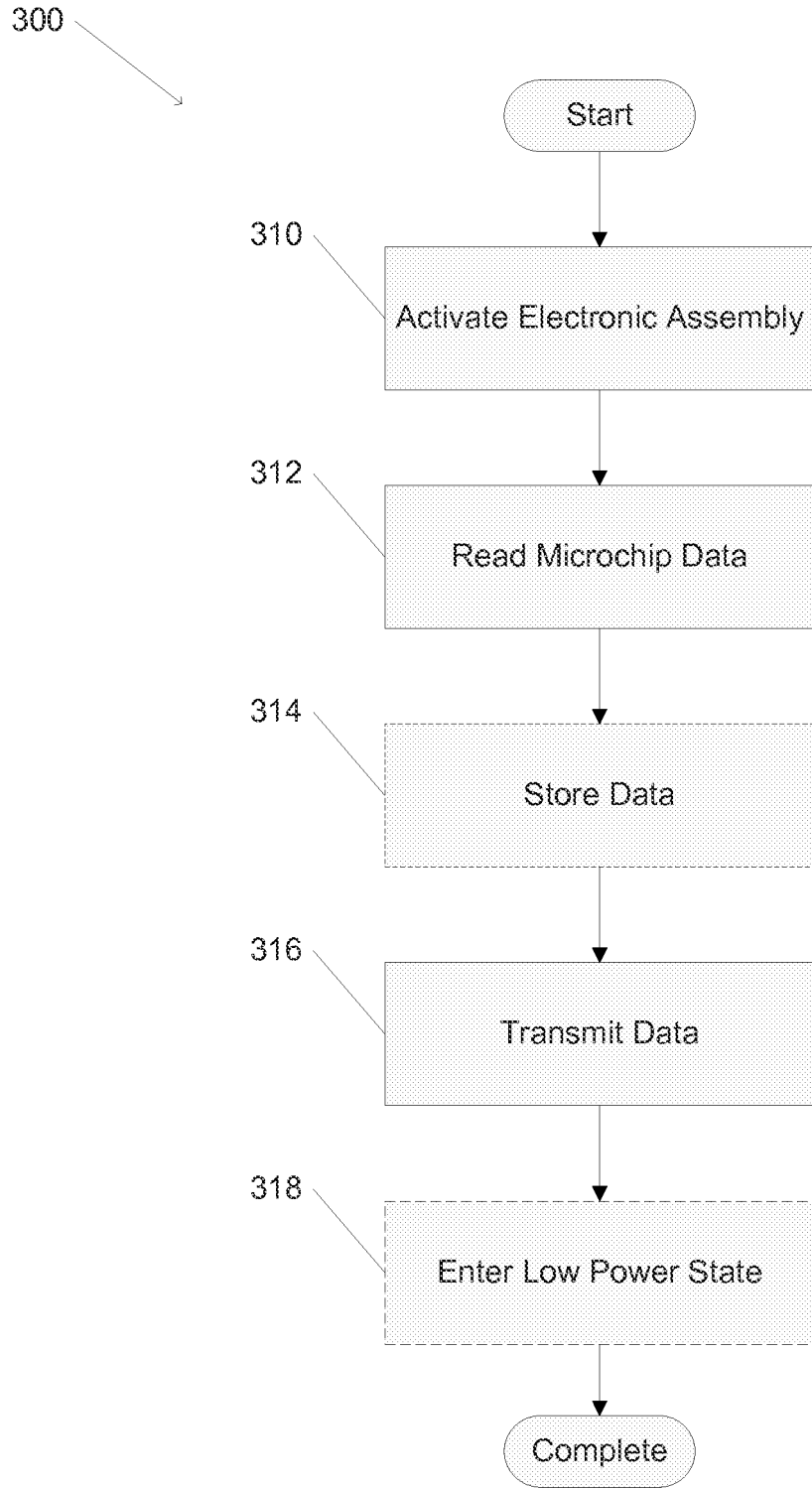
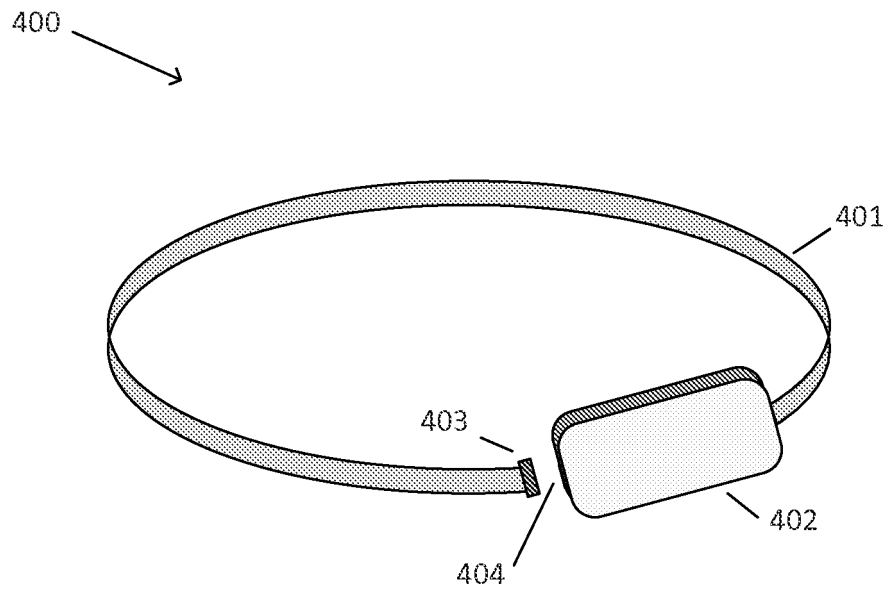

Fig. 2



**FIG. 3**



*FIG. 4*

**REFERENCES CITED IN THE DESCRIPTION**

*This list of references cited by the applicant is for the reader's convenience only. It does not form part of the European patent document. Even though great care has been taken in compiling the references, errors or omissions cannot be excluded and the EPO disclaims all liability in this regard.*

**Patent documents cited in the description**

- WO 2005104930 A [0002]
- US 20020010390 A [0002]
- GB 2437250 A [0002]
- FR 2801491 [0002]
- US 8219053 B [0033]

专利名称(译)	伴侣动物健康监测系统		
公开(公告)号	<a href="#">EP3188648A1</a>	公开(公告)日	2017-07-12
申请号	EP2015857279	申请日	2015-11-05
申请(专利权)人(译)	Allflex公司USA , INC.		
当前申请(专利权)人(译)	Allflex公司USA , INC.		
[标]发明人	STEWART ROBERT HILL NICHOLAS DE MEULUMEESTER JOHAN BOLTON BRIAN		
发明人	STEWART, ROBERT HILL, NICHOLAS DE MEULUMEESTER, JOHAN BOLTON, BRIAN		
IPC分类号	A61B5/00		
CPC分类号	A01K11/008 A01K29/005 G08C17/02 H04Q9/00 H04Q2209/47 H04Q2209/50		
优先权	62/075745 2014-11-05 US 14/932212 2015-11-04 US		
其他公开文献	EP3188648B1 EP3188648A4		
外部链接	<a href="#">Espacenet</a>		

#### 摘要(译)

描述了用于伴侣动物健康监测的系统和方法。在一个实施例中，一种动物健康监测系统，其包括位于伴侣动物上的电子组件，该电子组件包括微处理器，连接到微处理器的电源，以及植入伴侣动物中并且包括存储识别数据和温度的存储器的收发器和微芯片。传感器测量伴侣动物的温度，其中电子组件询问微芯片以获得识别数据和温度数据，并发送识别数据和温度数据。