

(19)



(11)

EP 2 663 230 B1

(12)

EUROPEAN PATENT SPECIFICATION

(45) Date of publication and mention of the grant of the patent:
18.03.2015 Bulletin 2015/12

(51) Int Cl.:
A61B 5/08 (2006.01) A61B 7/00 (2006.01)
A61B 5/11 (2006.01) A61B 5/00 (2006.01)

(21) Application number: **12700537.9**

(86) International application number:
PCT/IB2012/050108

(22) Date of filing: **10.01.2012**

(87) International publication number:
WO 2012/095783 (19.07.2012 Gazette 2012/29)

(54) **IMPROVED DETECTION OF BREATHING IN THE BEDROOM**

VERBESSERTE DETEKTION VON ATEMZYKLEN IM SCHLAFZIMMER

DÉTECTION AMÉLIORÉE DE LA RESPIRATION DANS UNE CHAMBRE

(84) Designated Contracting States:
AL AT BE BG CH CY CZ DE DK EE ES FI FR GB GR HR HU IE IS IT LI LT LU LV MC MK MT NL NO PL PT RO RS SE SI SK SM TR

(74) Representative: **Coops, Peter Philips**
Intellectual Property & Standards
P.O. Box 220
5600 AE Eindhoven (NL)

(30) Priority: **12.01.2011 EP 11305029**

(56) References cited:
WO-A1-2008/145952 DE-A1-102004 033 907
US-A- 5 197 490

(43) Date of publication of application:
20.11.2013 Bulletin 2013/47

(73) Proprietor: **Koninklijke Philips N.V.**
5656 AE Eindhoven (NL)

- **SÉRIÈS F ET AL: "Comparison of snoring measured at home and during polysomnographic studies", CHEST, AMERICAN COLLEGE OF CHEST PHYSICIANS, US, vol. 103, no. 6, 1 June 1993 (1993-06-01), pages 1769-1773, XP009158270, ISSN: 0012-3692, DOI: 10.1378/CHEST.103.6.1769**

- (72) Inventors:
- **VAN VUGT, Henriette Christine**
NL-5656 AE Eindhoven (NL)
 - **DERKX, Rene Martinus Maria**
NL-5656 AE Eindhoven (NL)
 - **HEINRICH, Adrienne**
NL-5656 AE Eindhoven (NL)

EP 2 663 230 B1

Note: Within nine months of the publication of the mention of the grant of the European patent in the European Patent Bulletin, any person may give notice to the European Patent Office of opposition to that patent, in accordance with the Implementing Regulations. Notice of opposition shall not be deemed to have been filed until the opposition fee has been paid. (Art. 99(1) European Patent Convention).

Description

FIELD OF THE INVENTION

[0001] The invention relates to the field of unobtrusively detecting respiration.

BACKGROUND OF THE INVENTION

[0002] Respiration is an important parameter that gives an indication of the physiological state of a person, e.g., whether the person is in a relaxed state or sleeping. Sleep and relaxation parameters such as respiration can be measured in different ways, and sleep laboratories often make use of obtrusive sensors such as EEG/PSG or other on-body sensors such as respiratory belts. Unobtrusive measuring of sleep parameters is more convenient for the sleeper, and unobtrusive measuring is preferred over existing obtrusive measurement techniques for home, medical and lifestyle solutions.

[0003] A living body information detection and display method is disclosed in US 2008/0312516 A1, together with a sleeping posture and position apparatus. This is used to correctly and suitably capture an abnormal condition in a living body while the living body is sleeping/lying on a bed or on the apparatus. Living body information and sleeping posture/position are captured by pressure sensors placed under a sleeper. The living body information may include, for example, respiratory information, body movement information, and sleeping posture.

[0004] Malakuti, K. reports a data acquisition system for monitoring sleep, wherein said data acquisition system uses 144 pressure sensors embedded in a bed sheet (Intelligent Bed Sensor) for measuring the pressure that the patient's body exerts on the bed. A video camera and a microphone recorded additional information to be used for evaluating the Intelligent Bed Sensor and are not part of the data acquisition system (Malakuti, I. Towards an Intelligent Bed Sensor: Non-intrusive Monitoring of Sleep Disturbances via Computer Vision Techniques; 2008, Thesis, University of Victoria).

[0005] International Publication No. WO 2008/145952 A1 discloses a body characterising system comprising a computing device, an optical imaging device to capture one or more images, and a scale estimator comprising an optical distance measuring device, the computing device comprising an image processor to identify the image of the user within the background of one or more captured images, and in which the computing device is operable to estimate the scale of the image of the user from the scale estimator, and to generate data descriptive of the user's body dependent upon to the identified image of the user and the estimated scale of the identified image of the user.

[0006] Document DE 10 2004 033 907 A1 teaches a device for monitoring a patient with regard to the breathing and/or snoring, the device comprising an infrared camera with an infrared lamp and a microphone.

[0007] Sériès, F. and colleagues (Sériès, F. et al. Comparison of snoring measured at home and during polysomnographic studies. Chest 1993; 103;1769-1773) compare the characteristics of snoring in the home environment with those of the sleep laboratory in that breathing sounds were recorded with two microphones symmetrically placed on either side of the bed to eliminate any sleep interferences by the apparatus.

[0008] To detect respiration unobtrusively, a set of small microphones can be used that can be positioned on the side of a person's bed, close to the person's head. For example, Sériè, F. and Marc, I. reported recording of snoring by two microphones which were placed symmetrically on each side of a bed, 70 cm above the bed surface and 85 cm apart, and angled to point directly toward the centre of the bed at the normal head position. The signal was preamplified, mixed, equalised and analysed with a spectrum analyser to get the snoring sound pressure level. To take into account the acoustic characteristics of the recording system, a calibration of the sound signal preceded the sleep studies. The sensitivity of the equaliser was adjusted to give a Pink Noise an intensity of 77 dB SPL. Following this procedure the equalised signal of the breathing noise was analysed by the spectrum analyser and transferred to a computer for interpretation (Sériè, F. and Marc, I., Thorax 1994;49:562-566).

[0009] However, breathing produces a relatively weak sound signal compared to snoring. Moreover, other sounds than just breathing may be present in a bedroom or relaxation area, e.g., from ventilation, from movements of the person him/herself, noises or breathing of another person, and the like. These other sounds can be regarded as noise that is detected on top of the "desired" respiration signal, and renders measuring and analysis of the breathing more difficult.

[0010] Using two microphones at the same time, wherein said microphones are arranged on opposite sides of the person's head, may be useful for proper detection of the person's respiration. For example, the two signals from said microphones may be combined. However, this method may be improved upon by taking into account information on the person's head position.

SUMMARY OF THE INVENTION

[0011] It is an object of the invention to provide a method for unobtrusively measuring a person's respiration.

[0012] The object may be achieved by a system comprising at least two microphones, at least one video camera, an infrared light source for illumination in the dark, offering the possibility to project an infrared pattern, wherein said at least two microphones are operatively linked to said at least one camera. The camera and illumination source can be integrated in one casing. Said at least two microphones are positioned on either side of the person's bed close to the person's head position to measure the respiration of said person. Said camera is

positioned to capture images indicating the relative position of the person's head to the at least two microphones. The images captured by the camera permits estimation of the exact position of the person like if he is lying on his back (supine position), in a lateral position on either the right side or the left side, or on the belly (prone position) by analyzing the light reflected from said person or the blanket. Analyzing of the images may also allow distinguishing whether more than one person is in the bed so as to identify the target person.

[0013] In a preferred embodiment of the system, said at least two microphones are steerable. Preferably, said at least two microphones are mechanically and/or electronically steerable. Steerability of the at least two microphones permits to improve signal-to-noise ratio when respiration of the person is measured, in particular when respiration is measured in the presence of noise point-sources.

[0014] In another or additional preferred embodiment of the system, the at least one camera or an additional camera is positioned above the height of the bed surface, preferably shifted beyond the foot end of the bed. This position of a camera is superior for capturing the light reflected from the person lying in bed or from the blanket said person may be covered with. This position of the camera is preferred for determining whether the person is lying in either supine or prone position, or in lateral position to its right or left side and to indicate the distance between the head and the microphones.

[0015] In another or additional preferred embodiment, the at least one camera is positioned at the foot end or side of the bed, close to the corner of the bed between the foot end and the side of the bed where the sleeping person is located, above the height of the bed surface. This position of the camera permits better motion analysis of the whole body of the person, and in particular, extraction of the last top movement of the body's main axis.

[0016] In a preferred embodiment of the system, the system further comprises a digital signalling processor and/or an adaptive filter for providing an enhanced and/or improved signal output of the signals received from the at least two microphones and provided from said at least two microphones to said digital signalling processor or adaptive filter.

[0017] It is an object of the invention to provide a method for unobtrusive measuring a person's respiration.

[0018] Said object is achieved by a method wherein images of a person lying down or lying in bed are captured by at least one video camera and are analysed to indicate where the person's head is positioned relative to at least two microphones which are positioned on either side of the person's bed and/or to indicate whether said person is lying in supine position, prone position or lateral position to its left or right side. The method further comprises computing the distance of the person's head to said at least two microphones, and to use said distances as parameters in audio analysis of signals obtained from at

least one of said at least two microphones.

[0019] In a preferred embodiment of the invention, the images captured by said at least one camera are analyzed for motion of the whole body of said person, in determining the main body axis of the body of said person, and in extracting the last top movement of the main body axis. This motion analysis of the whole body of said person permits to precisely indicate where the person's head is positioned relative to the at least two microphones, and to compute the distance of the person's head to each of said at least two microphones such that the at least two microphones may be steered for improving the breathing to be measured and/or to improve the signal-to-noise ratio.

[0020] In another preferred or additional embodiment of the invention, the images are analyzed for the distribution and/or pattern of the light reflected from the person or from a blanket covering said person, and the position is determined that said person is laying in. This analysis permits to determine the microphone of said at least two microphones which is in the line-of-sight of the breathing person.

[0021] In a preferred embodiment of the invention, the computed distances of the person's head to the at least two microphones are used for steering at least one of said at least two microphones. The steering of at least one of the microphones improves recording of the desired breathing over noise, because the microphone in the line-of-sight of the breathing may be steered towards the person's head and/or the other microphone(s) may be steered away from a noise source thereby improving the signal-to-noise ratio. Preferably, the microphones are steered mechanically and/or electronically.

[0022] In a further preferred embodiment of the invention, the signals from the at least two microphones are processed in a digital signalling processor leading to an enhanced and/or improved signal output from the digital signalling processor for further analysis.

[0023] In a further preferred embodiment of the invention, the signals from the at least two microphones undergo adaptive filtering wherein the signal from the microphone out of the line-of-sight of the person's breathing is used to estimate the noise in the microphone in the line-of-sight of the person's breathing where said estimate of the noise is subtracted from the signal of the microphone in the line-of-sight of the person's breathing, said adaptive filtering leading to an enhanced signal output from the adaptive filter for further analysis.

BRIEF DESCRIPTION OF THE DRAWINGS

[0024] In the drawings:

Fig. 1 depicts the general set up of the system.

Fig. 2 outlines the video process for computing distance between head and microphones.

Fig. 3 illustrates an embodiment comprising steering of a spatial notch towards a point-source of noise.

Fig. 4 illustrates an embodiment comprising an adaptive filtering technique to improve signal-to-noise ratio.

Fig. 5 illustrates a situation wherein the heads of two persons are very close to at least one microphone.

DETAILED DESCRIPTION OF EMBODIMENTS

[0025] The present invention will be described with respect to particular embodiments and with reference to the figures, but the invention is not limited thereto, but only to the claims. The drawings described are only schematic and are non-limiting. In the drawings, the size of some of the elements may be exaggerated and not drawn on scale for illustrative purposes.

[0026] Where an indefinite or definite article is used when referring to a singular noun, e.g. "a", "an", "the", this includes a plural of that noun unless something else is specifically stated. Furthermore, the terms first, second, third and the like in the description and in the claims are used for distinguishing between similar elements and not necessarily for describing a sequential or chronological order. It is to be understood that the terms so used are interchangeable under appropriate circumstances and that the embodiments of the invention described herein are capable of operation in other sequences than described or illustrated herein. Moreover, the terms top, bottom, over, under, beyond and the like in the description and in the claims are used for descriptive purposes and not necessarily for describing relative positions. It is to be understood that the terms so used are interchangeable under appropriate circumstances and that the embodiments of the invention described herein are capable of operation in other orientations than described or illustrated herein. It is to be noted that the term "comprising", used in the present description and claims, should not be interpreted as being restricted to the means listed thereafter; it does not exclude other elements or steps. Thus, the scope of the expression "a device comprising means A and B" should not be limited to devices consisting only of components A and B. It means that with respect to the present invention, the only relevant components of the device are A and B.

[0027] Figure 1 depicts the general set up of a system that may be used for the present invention. The system comprises at least two microphones 1, 2 and at least one video camera with integrated infrared illumination with the possibility to illuminate the sleeping person with a pattern 3. Said at least two microphones 1, 2 are positioned on either side of the person's bed 4 close to the person's head position 5.

[0028] The video camera takes images of the resting or sleeping person. The images taken by the camera may precisely indicate where the person's head is positioned relative to the at least two microphones. In addition, the images taken by the camera permit estimation if the person is lying sideways on its left side or on its right side, or in either supine or prone position, in that the distribution

of the reflected light is analysed. A more detailed spatial analysis of the higher and lower reflected light intensities may give a first indication if the person is lying on its left or on its right side, i.e. facing the left microphone or the right microphone. The side said person is lying on affects the strength of the signal in the two microphones, e.g. the signal of the left microphone is stronger than the signal in the right microphone when a person is breathing to the left direction, and vice versa. More generally speaking, the microphone proximal to the person's head receives a stronger breathing signal than the microphone being distal to the person's head.

[0029] Also, if two persons are relaxing or sleeping in the same bed, camera images taken can indicate to where the persons and their heads are positioned. The position of the "target" person, i.e. the person who's respiration is to be monitored, and the other person, the so-called "noise" person, can be taken into account to detect the breathing of the "target" person by analyzing the movements of said two persons. Every time a person moves his/her head, the position of the head with respect to the two microphones is updated.

[0030] According to a first embodiment of the system, the camera images may indicate precisely where the person's head is positioned relative to the at least two microphones. The camera may thus be used as an off-body sleep monitoring device for video-based actigraphy. Motion detection and motion estimation is performed on consecutive images where highlighted motion areas are returned. Based thereon, orientation of the sleeping person may be extracted, and the location of the person's head. The body parts are segmented by dividing the main axis of the body based on general body proportions. When the head touches the pillow, i.e. the last movement of the head part, the location of the image is logged and the position of the head with respect to the two microphones is given to the audio analysis module. The video process for computing the distance between the head and the microphones is outlined in Fig. 2. When the head is moving throughout the night, the computed motion vectors are analyzed and an updated head position and orientation are given to the audio analysis.

[0031] Figure 2 shows that the motion analysis of the whole body of a person is used to determine the main body axis of the person. This is determined by analysing consecutive images captured by the video camera. The last top most movements of the main body axis are extracted, and the distance to the left microphone and to the right microphone is computed. The computed distances are then used as parameters in audio analysis of the person's breathing.

[0032] After knowing the location of the head with respect to the at least two microphones, the signal-to-noise ratio of the two microphones may be improved by steering the directional-pattern of the microphones towards the person asleep. This steering can be done either mechanically or electronically. Also such a microphone-array can place a spatial notch toward a noise point source. Figure

3 illustrates an example, wherein a fan is present as noise point-source 6 in the room, a spatial notch can be - electronically - steered toward this point source 6. For example, the diaphragm of the directional microphone 1 (e.g. a dipole microphone with a figure-of-eight beam pattern) is steered perpendicular to the noise point-source 6. In this way, the response of the microphones 1, 2 with respect to the noise point-source 6 is minimized, and the signal-to-noise ratio is improved. The signals obtained from the microphones 1, 2 are processed in a digital signalling processor 7 providing an enhanced signal output.

[0033] According to another and/or additional embodiment, the images taken by the camera may indicate to what side the person is breathing. Based on the distribution of the light reflected from the person in bed or from the blanket said person may lay underneath, it may be determined whether said person is lying sideways, or in either supine or prone position. When it is determined that the person is lying sideways, a more detailed analysis of the reflected light intensity pattern may be performed, and based on the orientation of the legs of said person, the side the person is facing to and thus the orientation of the person's head is derived. The reflected light in the leg area has a higher intensity than the non-body area. This difference in light intensity allows determining the side said person is facing to. Particularly, the angle and orientation of the legs are indicative factors for estimating the left or right side orientation. When a person is lying flat, face and head pose detection can be applied to estimate the angle of the face. Additionally, motion vectors which may be computed indicate the motion of the head, and may be used to estimate orientation the person's face. The video respiration analysis may be used in combination with the audio analysis to improve the audio signal analysis.

[0034] Knowing the orientation of the head of the person with respect to the microphones is very helpful when the breathing of the person is very soft. In such instances, as illustrated in Figure 4, a signal-to-noise ratio may be enhanced and/or improved. For this, the single microphone 2 which is in the "line-of-sight" of the breathing person is used as so-called "primary" microphone. The other microphone 1 is used as a noise reference microphone. Adaptive filtering techniques may be used to improve the signal-to-noise ratio.

[0035] The noise of noise point-source 6 is picked up by both microphones 1,2 while breathing of the person is mainly picked up by primary microphone 2. The adaptive filter 8 (AF) is adapted in such away that it produces an estimate of the noise in the primary microphone 2. By subtracting this estimated noise signal from the primary microphone signal, an enhanced output signal is produced where the noise of the noise point-source is ideally not present anymore.

[0036] According to another and/or additional embodiment, the images taken by the camera may indicate to where the two people and their heads are positioned when two persons are in the same bed, and both are

breathing. One person can be considered the "target" person whose respiration should be measured, and the other person is referred to as the "noise" person as for the breathing analysis. The two video analysis approaches sketched above to determine the location and orientation of the head of the sleeping person can be extended to the shared bed situation when two persons sleep in one bed. The image is divided and the two parts processed independently. Due to spatial concentration of the motion output per person and based on the assumption that the two persons do not sleep such that the two heads are touching each other, the two persons can be easily segmented for the video analysis.

[0037] After the analysis of the video has taken place and the location and orientation of both heads of the persons asleep are known, microphone signals can be processed in such a way that the influence of the bed partner is minimized in the breathing signal. A way to do this is by using the steered microphone technique as mentioned before. However, it might be the case that the bed-partner is very close to one of the two microphones, and the breathing of the bed-partner cannot be seen as a point-source any more.

[0038] As can be seen in Fig. 5, the breathing of the bed-partner 9 is picked up by right microphone 2, while the desired breathing is picked up by both (left and right) microphones 1, 2. It can not be made use of the adaptive filter technique as the desired breathing is picked up by both microphones and a clean noise reference can not be constructed. In such a case only the left microphone 1 is used for capturing the breathing of the desired breathing signal and excludes the signal from right microphone.

[0039] The invention is useful to make reliable applications in which proper measurement of breathing in the bedroom is important. Such application may for example be paced breathing systems, sleep coaching, systems for sleep analysis either in the home or the clinic, apnea screening systems and anti-snoring systems, also used either in the home or the clinic.

[0040] While the invention has been illustrated and described in detail in the drawings and foregoing description, such illustration and description are to be considered illustrative or exemplary and not restrictive; the invention is not limited to the disclosed embodiments. Other variations to the disclosed embodiments can be understood and effected by those skilled in the art in practicing the claimed invention, from a study of the drawings, the disclosure, and the appended claims. In the claims, the word "comprising" does not exclude other elements or steps, and the indefinite article "a" or "an" does not exclude a plurality. The mere fact that certain measures are recited in mutually different dependent claims does not indicate that a combination of these measures cannot be used to advantage. Any reference signs in the claims should not be construed as limiting the scope.

Claims

1. A method for unobtrusive measuring a person's respiration, said method comprising:
 - capturing images of a person lying down or lying in bed by at least one video camera,
 - analysing the images to indicate where the person's head is positioned relative to at least two microphones which are positioned on either side of the person's bed and/or to indicate whether said person is lying in either supine or prone position, or lateral position to its left or right side,
 - computing the distance of the person's head to at least two microphones positioned on opposite sides of the person's head, and
 - using the computed distances as parameters in audio analysis of the breathing of said person.
2. The method according to claim 1, **characterized in that** the captured images are analyzed for the motion of the whole body of said person, in determining the main body axis of said person, and in extracting the last top movement of the main body axis.
3. The method according to claim 1 or 2, **characterized in that** the images are analyzed for the distribution and/or pattern of the light reflected from the person or from a blanket covering said person, and **in that** the position is determined said person is lying in.
4. The method according to any one of claims 1 to 3, **characterized in that** the parameters are used for steering at least one of said at least two microphones.
5. The method according to claim 4, **characterized in that** the at least one microphone is steered mechanically or electronically.
6. The method according to any one of claims 1 to 5, **characterized in that** the signals from the microphones are processed in a digital signalling processor leading to an enhanced signal output from the digital signalling processor.
7. The method according to any one of claim 1 to 6, **characterized in that** the signals from the microphones undergo adaptive filtering wherein the signal from the microphone out of the line-of-sight of the person's breathing is used to estimate the noise in the microphone in the line-of-sight of the person's breathing wherein said noise is subtracted from the signal of the microphone in the line-of-sight of the person's breathing, said adaptive filtering leading to an enhanced signal output from the adaptive filter.

Patentansprüche

1. Verfahren zur unauffälligen Messung der Atemzyklen einer Person, wobei das genannte Verfahren Folgendes umfasst:
 - Erfassen von Bildern einer Person, die sich hinlegt oder im Bett legt, durch mindestens eine Videokamera,
 - Analysieren der Bilder, um anzugeben, wo sich der Kopf der Person in Bezug auf mindestens zwei Mikrofone befindet, die auf den beiden Seiten des Betts der Person positioniert sind, und/oder um anzugeben, ob die genannte Person in Rückenlage oder in Bauchlage oder auf ihrer linken oder rechten Seite liegt,
 - Berechnen des Abstands vom Kopf der Person zu mindestens zwei Mikrofonen, die an gegenüberliegenden Seiten des Kopfs der Person positioniert sind, und
 - Verwenden der berechneten Abstände als Parameter für die Audioanalyse der Atemzyklen der genannten Person.
2. Verfahren nach Anspruch 1, **dadurch gekennzeichnet, dass** die erfassten Bilder auf die Bewegung des gesamten Körpers der genannten Person hin analysiert werden, indem die Hauptkörperachse der genannten Person ermittelt wird und indem die letzte obere Bewegung der Hauptkörperachse extrahiert wird.
3. Verfahren nach Anspruch 1 oder 2, **dadurch gekennzeichnet, dass** die Bilder in Bezug auf die Verteilung und/oder das Muster des von der Person oder von einer die Person bedeckenden Decke reflektierten Lichts hin analysiert werden, und dadurch, dass die Lage ermittelt wird, in der die Person liegt.
4. Verfahren nach einem der Ansprüche 1 bis 3, **dadurch gekennzeichnet, dass** die Parameter verwendet werden, um mindestens eines der genannten mindestens zwei Mikrofone zu steuern.
5. Verfahren nach Anspruch 4, **dadurch gekennzeichnet, dass** das mindestens eine Mikrofon mechanisch oder elektronisch gesteuert wird.
6. Verfahren nach einem der Ansprüche 1 bis 5, **dadurch gekennzeichnet, dass** die Signale von den Mikrofonen in einem digitalen Signalprozessor verarbeitet werden, was zu einer verstärkten Signalausgabe von dem digitalen Signalprozessor führt.
7. Verfahren nach einem der Ansprüche 1 bis 6, **dadurch gekennzeichnet, dass** die Signale von den Mikrofonen einer adaptiven Filterung unterzogen werden, wobei das Signal von dem Mikrofon außer-

halb der Sichtlinie der Atemzyklen der Person verwendet wird, um das Rauschen in dem Mikrofon in der Sichtlinie der Atemzyklen der Person zu schätzen, wobei das genannte Rauschen von dem Signal des Mikrofons in der Sichtlinie der Atemzyklen der Person subtrahiert wird, wobei die genannte adaptive Filterung zu einer verstärkten Signalausgabe von dem adaptiven Filter führt.

Revendications

1. Procédé de mesure discrète de la respiration d'une personne, ledit procédé comprenant :

- l'acquisition d'images d'une personne allongée ou couchée dans un lit par au moins une caméra vidéo,
- l'analyse des images pour indiquer où la tête de la personne est positionnée par rapport à au moins deux microphones qui sont positionnés de chaque côté du lit de la personne et/ou pour indiquer si ladite personne est couchée sur le dos ou sur le ventre, ou sur le côté gauche ou droit,
- le calcul de la distance de la tête de la personne à au moins deux microphones positionnés sur des côtés opposés de la tête de la personne, et
- l'utilisation des distances calculées en tant que paramètres d'analyse audio de la respiration de ladite personne.

2. Procédé selon la revendication 1, **caractérisé en ce que** les images acquises sont analysées pour le mouvement du corps complet de ladite personne, dans la détermination de l'axe de corps principal de ladite personne et dans l'extraction du dernier mouvement supérieur de l'axe de corps principal.

3. Procédé selon la revendication 1 ou 2, **caractérisé en ce que** les images sont analysées pour la diffusion et/ou le motif de la lumière réfléchiée par la personne ou par une couverture recouvrant ladite personne, et **en ce qu'il** est déterminé la position à laquelle ladite personne est couchée.

4. Procédé selon l'une quelconque des revendications 1 à 3, **caractérisé en ce que** les paramètres sont utilisés pour diriger au moins l'un desdits au moins deux microphones.

5. Procédé selon la revendication 4, **caractérisé en ce que** l'au moins un microphone est dirigé mécaniquement ou électroniquement.

6. Procédé selon l'une quelconque des revendications 1 à 5, **caractérisé en ce que** les signaux provenant des microphones sont traités dans un processeur de

signalisation numérique engendrant une sortie de signal améliorée du processeur de signalisation numérique.

7. Procédé selon l'une quelconque des revendications 1 à 6, **caractérisé en ce que** les signaux provenant des microphones subissent un filtrage adaptatif, dans lequel le signal provenant du microphone hors de la ligne de vision de la personne respirant est utilisé pour estimer le bruit dans le microphone dans la ligne de vision de la personne respirant, dans lequel ledit bruit est soustrait au signal du microphone dans la ligne de vision de la personne respirant, ledit filtrage adaptatif engendrant une sortie de signal améliorée du filtre adaptatif.

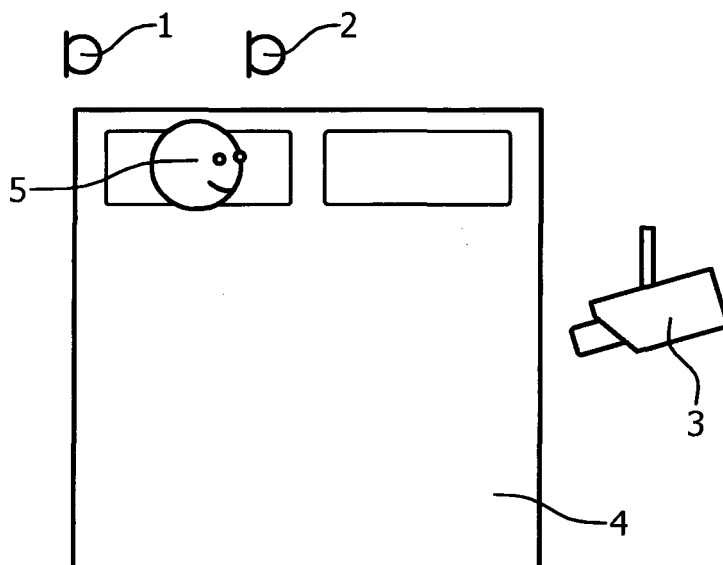

FIG. 1

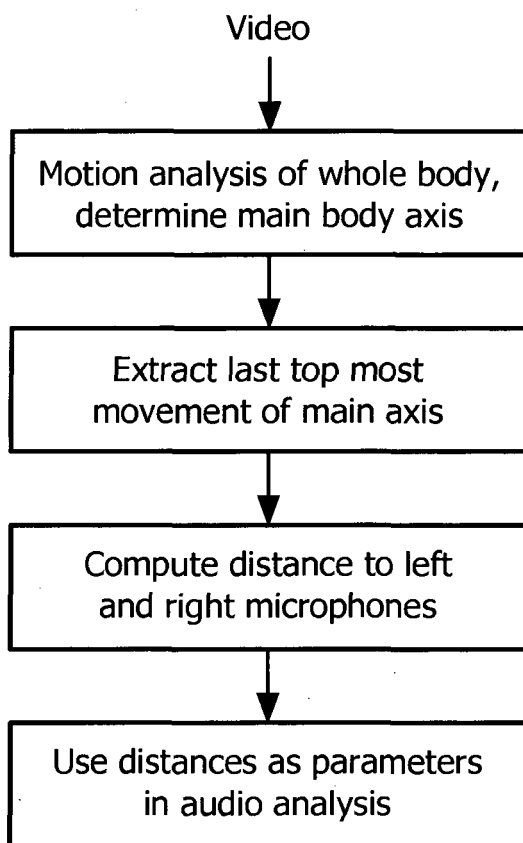

FIG. 2

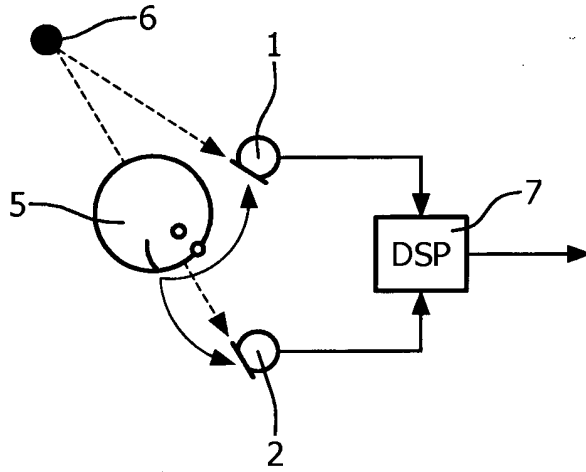

FIG. 3

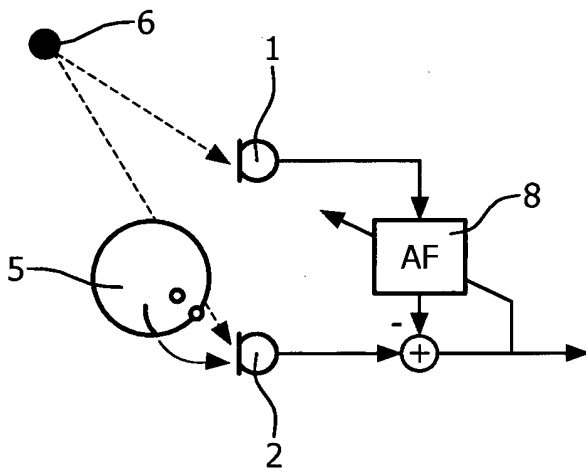

FIG. 4

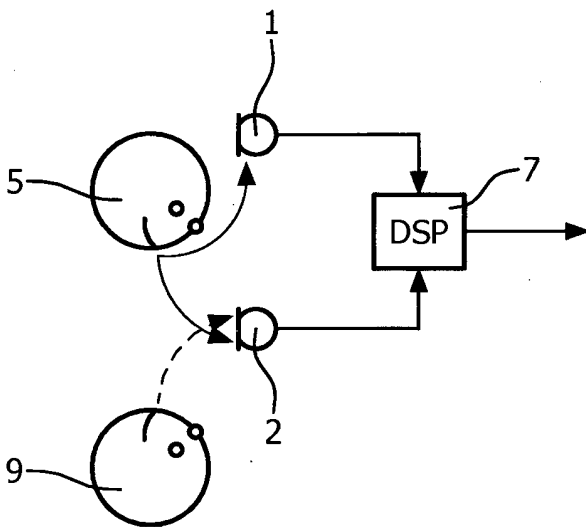

FIG. 5

REFERENCES CITED IN THE DESCRIPTION

This list of references cited by the applicant is for the reader's convenience only. It does not form part of the European patent document. Even though great care has been taken in compiling the references, errors or omissions cannot be excluded and the EPO disclaims all liability in this regard.

Patent documents cited in the description

- US 20080312516 A1 [0003]
- WO 2008145952 A1 [0005]
- DE 102004033907 A1 [0006]

Non-patent literature cited in the description

- **MALAKUTI, I.** Towards an Intelligent Bed Sensor: Non-intrusive Monitoring of Sleep Disturbances via Computer Vision Techniques. *Thesis*, 2008 [0004]
- **SÉRIÈS, F. et al.** Comparison of snoring measured at home and during polysomnographic studies. *Chest*, 1993, vol. 103, 1769-1773 [0007]
- **SÉRIÈ, F. ; MARC, I.** *Thorax*, 1994, vol. 49, 562-566 [0008]

专利名称(译)	改善了卧室呼吸的检测		
公开(公告)号	EP2663230B1	公开(公告)日	2015-03-18
申请号	EP2012700537	申请日	2012-01-10
[标]申请(专利权)人(译)	皇家飞利浦电子股份有限公司		
申请(专利权)人(译)	皇家飞利浦N.V.		
当前申请(专利权)人(译)	皇家飞利浦N.V.		
[标]发明人	VAN VUGT HENRIETTE CHRISTINE DERKX RENE MARTINUS MARIA HEINRICH ADRIENNE		
发明人	VAN VUGT, HENRIETTE CHRISTINE DERKX, RENE MARTINUS MARIA HEINRICH, ADRIENNE		
IPC分类号	A61B5/08 A61B7/00 A61B5/11 A61B5/00		
CPC分类号	A61B5/4809 A61B5/0077 A61B5/0803 A61B5/0816 A61B5/1116 A61B5/4806 A61B5/4818 A61B5/6891 A61B7/003		
代理机构(译)	合作社, PETER		
优先权	2011305029 2011-01-12 EP		
其他公开文献	EP2663230A1		
外部链接	Espacenet		

摘要(译)

用于不引人注意地测量人的呼吸的方法和系统技术领域本发明涉及一种用于不显眼地测量人的呼吸的方法和系统，其中，基于图像基于人头部到所述麦克风的距离来操纵位于人床两侧的至少两个麦克风。由摄像机拍摄。

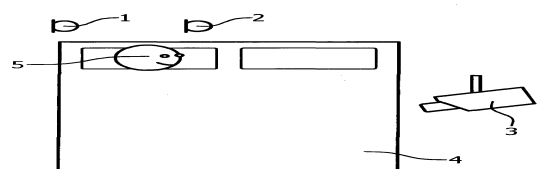

FIG. 1

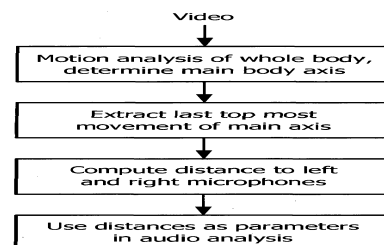

FIG. 2