



(11) **EP 2 296 540 B1**

(12) **EUROPEAN PATENT SPECIFICATION**

(45) Date of publication and mention of the grant of the patent:
26.10.2016 Bulletin 2016/43

(51) Int Cl.:
A61B 5/04 (2006.01) **A61B 5/0402** (2006.01)
A61B 5/00 (2006.01) **A63B 24/00** (2006.01)
A61B 5/024 (2006.01)

(21) Application number: **08761714.8**

(86) International application number:
PCT/FI2008/050318

(22) Date of filing: **02.06.2008**

(87) International publication number:
WO 2009/147279 (10.12.2009 Gazette 2009/50)

(54) **METHOD AND APPARATUS IN CONNECTION WITH EXERCISE**

VERFAHREN UND GERÄT ZUR KÖRPERLICHEN BETÄTIGUNG

PROCÉDÉ ET APPAREIL UTILES DANS LE CADRE DE L'EXERCICE PHYSIQUE

(84) Designated Contracting States:
AT BE BG CH CY CZ DE DK EE ES FI FR GB GR HR HU IE IS IT LI LT LU LV MC MT NL NO PL PT RO SE SI SK TR

(56) References cited:
EP-A1- 1 852 062 EP-A2- 1 133 950
WO-A2-2008/026073 RU-C1- 2 118 117
US-A- 4 106 495 US-A- 5 803 084
US-A1- 2005 209 525 US-A1- 2007 219 059

(43) Date of publication of application:
23.03.2011 Bulletin 2011/12

(73) Proprietor: **Polar Electro Oy**
90440 Kempele (FI)

(72) Inventor: **KINNUNEN, Hannu**
90800 Oulu (FI)

(74) Representative: **Kolster Oy Ab**
Iso Roobertinkatu 23
PO Box 148
00121 Helsinki (FI)

- **KIYOSHI WATANABE ET AL:** "The relationship between exercise-induced R wave amplitude changes and QRS vector loops", **JOURNAL OF ELECTROCARDIOLOGY**, vol. 14, no. 2, 1 January 1981 (1981-01-01), pages 129-138, XP055131267, ISSN: 0022-0736, DOI: 10.1016/S0022-0736(81)80047-7
- **JAN A KORS ET AL:** "Spatial QRS-T angle as a risk indicator of cardiac death in an elderly population", **JOURNAL OF ELECTROCARDIOLOGY**, vol. 36, 1 December 2003 (2003-12-01), pages 113-114, XP055131281, ISSN: 0022-0736, DOI: 10.1016/j.jelectrocard.2003.09.033
- **TOOR M ET AL:** "Electrocardiographic changes during daily work and acute exercise in permanent inhabitants of hot areas", **AMERICAN HEART JOURNAL, MOSBY- YEARBOOK INC, US**, vol. 69, no. 2, 1 February 1965 (1965-02-01), pages 181-194, XP022903679, ISSN: 0002-8703, DOI: 10.1016/0002-8703(65)90035-9 [retrieved on 1965-02-01]

EP 2 296 540 B1

Note: Within nine months of the publication of the mention of the grant of the European patent in the European Patent Bulletin, any person may give notice to the European Patent Office of opposition to that patent, in accordance with the Implementing Regulations. Notice of opposition shall not be deemed to have been filed until the opposition fee has been paid. (Art. 99(1) European Patent Convention).

Description

FIELD

5 **[0001]** The invention relates to sports, particularly to fitness exercises.

BACKGROUND

10 **[0002]** Heart rate is often used as a measure of the exertion level of a person in a fitness exercise. However, in some circumstances, the heart rate does not apply as a true indicator of stress level of an exercise. That is, in some cases a high heart rate, for instance, is not an indication of high work rate of the person.

[0003] There is thus a need to provide an improved way of determining the exertion level of a fitness exercise on a person.

15 **[0004]** Kiyoshi Watanabe et al.: "The relationship between exercise-induced R wave amplitude changes and QRS vector loops", Journal of Electrocardiology, vol. 14 no. 2, January 1981 (1981-01-.01), pages 129-138, relates to coronary heart disease (CHD) diagnosis. Vectorcardiograms were recorded during supine rest and bicycle exercise in 13 normals and 33 patients with CHD. QRS vector loops were formed and QRS vector angles were calculated. It was found out that the shift in the maximal QRS vector angle rather than an amplitude change is the major contribution to the changes in the R wave amplitude in the X lead during the exercise.

20 **[0005]** Jan A Kors et al: "Spatial QRS-T angle as a risk indicator of cardiac death in an elderly population", Journal of Electrocardiology, vol. 36, 1 December 2003 (2003-12-01), pages 113-114, studies the predictive value of the spatial QRS-T angle for fatal and nonfatal cardiac events in an elderly general population.

[0006] EP 1852062 discloses a portable arrangement for generating physical exercise instructions based on the measurement of the user heart rate via electrodes.

25 **[0007]** EP 1133950 discloses determination of stress level during a fitness exercise. The method comprises measuring the person's heart rate information during the fitness exercise and informing the person if, during the fitness exercise, the value of a stress parameter formed from the measured heart rate information exceeds a threshold value formed for the stress parameter before the fitness exercise. The stress parameter is formed using the value of the person's expiratory flow.

30 SUMMARY

[0008] According to an aspect of the present invention, there is provided a portable arrangement as specified in claim 1.

[0009] According to another aspect of the present invention, there is provided a method as specified in claim 10.

35 **[0010]** According to another aspect of the present invention, there is provided a computer-readable medium comprising a computer program product as specified in claim 14.

DRAWINGS

40 **[0011]** In the following the invention will be described in greater detail by means of preferred embodiments with reference to the accompanying drawings, in which

Figure 1 highlights installation of electrodes on a person carrying out a fitness exercise;

Figure 2 illustrates ECG components in orthogonal directions;

45 Figure 3 highlights the time-dependent properties of a multidimensional ECG signal;

Figure 4 shows an embodiment of a method;

Figure 5 shows an embodiment of an apparatus; and

Figure 6 shows another embodiment of an apparatus.

50 DESCRIPTION OF SOME EMBODIMENTS

[0012] Figure 1 shows one example of measurement of multidimensional electrocardiographic data from a person 100 relating to a fitness exercise. The measured data may be processed during and/or after the exercise. The electrocardiographic data measured from the person is expected to be illustrative of data measured from a healthy person having no heart disorders, for instance. An ECG (Electrocardiogram) is a recording of the changes in electrical potentials between different sites on the skin and arises from the periodic activity of the cardiac musculature. The ECG reflects the depolarization and repolarization events connected with cardiac excitation and conduction. However, an ECG does not provide direct information about the contraction and pumping efficiency of the heart.

[0013] An ECG curve describes the migration of the excitatory front on the myocardium. Each deflection originates from the propagating depolarization or repolarization fronts in different parts of the cardiac muscle. The ECG represents the superposition of the depolarization and repolarization on different sites of the heart.

5 [0014] A first deflection in the normal ECG is a P wave representing atrial depolarization. The wave for atrial repolarization is masked by the succeeding waves. Q, R and S waves together constitute a QRS-complex which represents ventricular depolarization. In the QRS complex, every initial negative deflection is denoted by Q, every positive deflection by R, and every negative deflection that follows R, by S. The QRS complex is succeeded by a T wave which reflects repolarization of the ventricles.

10 [0015] Activation of the ventricular muscle takes place from endocardium to epicardium and from the apex of the ventricles to the base. The depolarization of the ventricle is almost simultaneous in the entire ventricular musculature causing a steep R wave, whereas the duration of the repolarization phase in different parts of the ventricles vary resulting in a less steep T wave. In most leads, the T wave is deflected in the same direction from the isoelectric line as the major component of the QRS complex. This indicates that the repolarization process proceeds in a direction counter to the depolarization process. By using several ECG leads for measuring several ECG signal components, and by following changes especially in repolarization phase, it is possible to gain information about the contraction and pumping efficiency of the heart.

15 [0016] In rest, the T wave is typically deflected in the same direction from the isoelectric line as the major component of the QRS complex which typically is the R component. In vectorcardiography, this leads to a situation where the QRS loop and the T loop are directed close to the same direction. In practice, this means that the activation of the ventricular muscle takes place from endocardium to epicardium and from the apex of the ventricles to the base, whereas the repolarization proceeds in the opposite direction. This situation enables optimal pumping efficiency. An explanation is that the center part of the epicardium is mechanically more elastic at the time when the apex contracts and therefore the emptying of the chambers, particularly that of the left chamber, is better.

20 [0017] During exercise, together with increased exercise intensity blood pressure rises remarkably, respiratory activity increases and the oxygen demand of heart muscle increases. As coronary arteries are located on the surface of the heart that is surrounded by the lungs, and are thus exposed to the pressure changes that take place with inhalation and expiration in the lungs, exercise affects the heart's oxygen supply and its pumping efficiency, particularly when intensity is close to maximum and/or when exercise duration is long.

25 [0018] Changes in the heart's oxygen need vs. supply are reflected in the repolarization period at that part of heart muscle. Also if there are changes in ion concentrations in the body fluids, they can be reflected particularly in the repolarization phase of heart cell activity. If repolarization is delayed in some part of the heart, it may adversely affect the following depolarization period as well. Local and small changes can negatively affect the heart's pumping efficiency even though they cannot be monitored with surface ECG. However, by combining the surface ECG information from several directions and following the changes it can be possible to detect such local and small changes that affect the heart's pumping efficiency. In one embodiment, the changes in the angle between the R loop and the T loop are followed. In another embodiment, the changed vectorcardiographic information are combined with the heart rate information, because some part of the information regarding the change is related to the heart rate information and some part of the information is related to contraction or pumping efficiency.

30 [0019] The person 100 depicted in Figure 1 has four measurement electrodes 102 to 108 installed on him. The electrode 106 may be placed on the chest, the electrode 104 may be placed on the side, the electrode 102 may be placed on the back and the electrode 108 may be positioned on the shoulder of the person. ECG signal components of a multidimensional ECG data may be measured over each pair of electrodes. For instance, a first signal component may be measured by using a coupling of electrodes 102 and 104, a second signal component may be measured by a coupling of electrodes 102 and 106, and a third signal component may be measured by using a coupling of electrodes 104 and 106.

35 [0020] The multidimensional electrocardiographic data includes at least two spatially separated electrocardiographic signal components. The two spatially separated components are obtainable by using two of the couplings provided by at least three electrodes 102 to 106. The signal component in x direction may be extracted from each coupling signal and the extracted x signal components may be combined to a combination signal illustrative of the electrocardiographic signal in the x direction. The two other orthogonal directions y and z may be handled correspondingly.

40 [0021] The electrodes 102 to 106 may be positioned on the person such that they allow detection of signal components in orthogonal directions x, y and z depicted in the figure. In an embodiment, the electrodes 102 to 106 are positioned orthogonally with respect to each other that is each of them reside on one of the x, y and z axis. Alternatively, the electrodes 102 to 106 may be positioned non-orthogonally, and the orthogonal components x, y and z may be calculated from the measured signals. For instance, as the figure shows, the electrodes in the couplings 104-106 and 102-104 are positioned such that they allow detection of an electrocardiographic signal at least in x and z directions. To detect the y-component as well, the electrodes 102 to 106 may be placed at different heights of the person, so the back electrode 102 may be positioned higher on the person than the chest electrode 106, for instance. For effective detection of the y-component, instead of the electrode 104, the shoulder electrode 108 may be used.

[0022] Figure 2 illustrates the electrocardiographic signal components in orthogonal directions x, y and z. The topmost graph illustrates the x-component, the y-component is depicted in the middle and the z-component at the bottom of the figure. Time windows of R and T waves are illustrated with reference numerals 200 and 202, respectively.

[0023] It may be seen that the time structure of the signal components measured in different directions may differ somewhat from each other. In the figure, the R peak in the z-component is higher than in the y-component and the T waves are inverse to each other, for instance.

[0024] Determination of the multidimensional ECG may be done in many ways from the signals measured by the pairs of electrodes. In one embodiment, the x components of all the couplings are combined, by averaging for example, to a combination x component. The y and z signals may be handled correspondingly. The combination x, y and z signals may then be combined to a combination multidimensional ECG.

[0025] Alternatively, multidimensional signals may be formed coupling-specifically, and the multidimensional coupling-specific signals may then be combined to a combination multidimensional signal, which may be presented as a vector-cardiographic representation. In this case, averaging may be used.

[0026] Figure 3 shows a vectorcardiographic representation of two wave components. The R loop 306 is obtained by plotting the sampling points of x, y, z into a multidimensional coordinate system, wherein the sampling points are recorded during the R time window 200 illustrated in Figure 2.

[0027] The T loop 308 is obtained by plotting the sampling points of x, y, z into a multidimensional coordinate system, wherein the sampling points are recorded during the T time window 202 of Figure 2.

[0028] In an embodiment, a vector 300 between the origin and the furthest point from the origin is used for characterizing the R wave in the xyz coordinate system. Similarly, a vector 302 depicting the combination T wave may be provided by connecting a line between the origin and the outmost point of the loop 308. A vector measure between these two vectors 300, 302 may be determined. The vector measure may be the angle 304 between the combination R (300) and T (302) vectors, for instance. In an embodiment, the vector measure is TCRT (Total Cosine R to T). The vector measure may also be any other measure that can be determined from the relationship of the R and T vectors in the orthogonal coordinate space.

[0029] The amplitude/length and direction of the vectors representing the R and T waves may change over the time. In an embodiment, the vectors are updated continuously based on fifty previous heartbeats, for instance. Alternatively, the vectors may be updated only after a predetermined number of heartbeats has occurred or a predetermined time period has lapsed.

[0030] Figure 4 shows an embodiment of a method. The method may be applied in connection with a fitness exercise carried out by a healthy person having no heart disorders, for instance.

[0031] In 402, ECG is measured from the person by using at least two spatially separated electrode couplings. At least three electrodes 102 to 106 may be used for establishing the spatial separation of the couplings. If there are three electrodes 102 to 106 positioned in spatially different positions on the person, a first coupling may be between the first and second electrodes 102, 104, and the second coupling may be between the first and third electrodes 102, 106. In a first embodiment, the measurement on the couplings is simultaneous so that both signals on both couplings are measured all the time. In another embodiment, the measurement on the couplings is time-divided such that the measurement is carried out on the couplings alternately. In this case, it may be assumed that the measurement of the coupling not being measured is constant over the non-measurement period. We may assume an example where a first coupling and a second coupling are used. The first coupling is measured during a first time interval and the second coupling during a second time interval. During the second time interval, when the first coupling is not measured, the measurement results from the first coupling during the first time interval may be used in determining the multidimensional ECG, RT vectors and the vector measure.

[0032] In 404, a multidimensional ECG representation is formed from the signals measured in 402. The multidimensional representation here means a representation including at least three mutually different directions such that the directions are not in a plane. That is, the third direction is not in the plane determined by the two other directions. In an embodiment, the three directions are mutually orthogonal directions.

[0033] The multidimensional ECG is basically an ECG, where the signal components in mutually orthogonal directions x, y and z have been combined. In the multidimensional ECG, as in usual ECG, time windows representing the R wave and the T wave may be determined. The time window representing the R wave, for instance, may include upward and downward directing sections or predetermined length around the peak.

[0034] In an embodiment, a vectorcardiographic representation of the multidimensional ECG is provided. During a heart beat, that is during a PQRST cycle of the ECG, the vectorcardiographic presentation is a vector having time-varying characteristics in view of the amplitude and directions. With regard to the R peak, a curve representing sampling points of the multidimensional ECG signal during the R time window may be drawn. The vector representation of the R wave may correspond to a connecting line from the origin to the furthest point of the loop. Similarly to a vector representing the R window, a vector representing the T window may be determined.

[0035] In 406, a vector measure is determined from the data formed in 404. As explained above, vectors representing

R and T waves and varying in direction and magnitude over time is drawn. Each of these vectors may be averaged over time. The vectors may be averaged vectors of the latest 100 heart beats, for instance.

[0036] In an embodiment, the vector measure characterizes the relationship between the R and T vectors. The vector measure may be the angle between the R and T vectors or TCRT (Total Cosine R to T), for instance. Small TCRT may indicate high pumping efficiency of the heart. If the TCRT is high, the heart's pumping efficiency may be reduced. Small TCRT refers to the normal situation with normal depolarization and repolarization in all parts of heart. This can be linked to high pumping efficiency because of adequate filling of the ventricles, adequate oxygenation of heart cells (capillary flow), and proper ion concentrations in the heart cells.

[0037] In 408, a fitness-exercise-related parameter is determined on the basis of the vector measure formed in 406. The exercise-related parameter may be an exertion level or the energy consumption of the person in the fitness exercise. A large deviation between the R loop 306 and the T loop 308 may indicate smaller energy consumption than a small deviation with a constant heart rate.

[0038] The exercise-related parameter may also be an instruction indicating on which level the exercise could be started or continued. The conclusions are given in Table 1 below.

[0039] The parameter may also characterize mental stress of the person before or after the exercise. Alternatively, a capacity parameter of the person may be determined. The capacity parameter may indicate if the person is in a good or bad physical condition or if the plasma volume of the person is high.

[0040] The conclusions of 408 may be drawn up solely on the basis of the vector measure determined in 406. For instance, if TCRT is over a predetermined threshold value, this may be indicated to the person. A high TCRT may indicate to the person that training on that day should be light or that there should be no training at all.

Table 1. Instructions to the person in view of HR and TCRT values

HR low	HR moderate	HR high
TCRT low - person at rest / well recovered - HR corresponds to rest HR -> <i>ok to start exercise</i>	TCRT low - good physical condition - higher than normal plasma volume -> <i>ok to continue exercise</i>	TCRT low - good physical condition - higher than normal plasma volume -> <i>ok to continue exercise</i>
TCRT normal - low exertion level - HR corresponds to exertion level -> <i>ok to exercise</i>	TCRT normal - HR corresponds to exertion level - <i>ok to continue exercise</i>	TCRT normal - HR corresponds to exertion level - <i>ok to continue exercise</i>
TCRT high - stress or overexertion on the person -> <i>not advisable to start exercise</i>	TCRT high - HR too high compared to exertion level - Heart pumping capacity lower than normal -> <i>not optimal to continue exercising on current level</i>	TCRT high - HR too high compared to exertion level - Heart pumping capacity lower than normal -> <i>not optimal to continue exercising on current level</i>

[0041] Table 1 shows how the conclusions to control the exercise may be drawn solely on the basis of the vectorcardiographic measure. The first two rows indicate the situations where the TCRT is low or normal. Independent of the HR value, the low or normal value of the TCRT may be an indication that it is appropriate to start or continue an exercise.

[0042] However, if the TCRT value exceeds a predetermined threshold value, that is the limit between the "normal TCRT" and the "high TCRT", this is an indication that the heart's pumping efficiency is reduced. An indication may be given to the user either to stop the exercise or at least to reduce the stress of the exercise.

[0043] In another embodiment, the vector measure may be used together with a heart rate parameter, such as heart rate (HR), to provide instructions for the user in relation to the fitness exercise. Two or more categories for the heart rate may be provided, such as low, moderate and high heart rate. Furthermore, two or more categories for the vector measure, such as TCRT, may be provided. In an embodiment, the categories may be low, normal and high TCRT.

[0044] Before the exercise, if the heart rate is low and the TCRT is low/normal, it may be concluded that the person is not overstressed and a training exercise may be started.

[0045] If the TCRT is high despite the fact that the HR is low, this may indicate that the person is mentally or physically overstressed and should perhaps not consider starting a fitness exercise.

[0046] During the exercise, if the person has moderate HR and low TCRT, this may be an indication of high performance capability. It may be concluded that the exertion level of the exercise level is suitable for the person.

[0047] If the person has moderate HR and high TCRT, this may be an indication that the person is not fully fit to carry on with the exercise at that level. It may be that the person has not fully recovered from a previous exercise, for instance. This information may be communicated to the person.

[0048] If the person has high HR and low TCRT, this may be an indication of good physical condition of the person. If the HR is high and TCRT moderate, the HR corresponds to the person's exertion level and it is appropriate for the person to exercise at that HR level.

[0049] If the person has high HR and high TCRT, this may be an indication that the person's exertion level is lower than the HR level indicates. The case may be that the person has not fully recovered from a previous exercise. It is inappropriate for the person to exercise at that HR level and this may be indicated to the person.

[0050] The references to TCRT low/high may refer to absolute values of TCRT. Alternatively, those references may be indicative of the relationship TCRT/HR. The absolute or relative values may be considered as such or they may be personalized for the person carrying out the fitness exercise. That is, a limit for the TCRT/HR relation may be different for different persons. A reference exercise and/or physiological data of the person may be collected to determine the threshold values.

[0051] Although the above refers to HR and TCRT, the embodiments may use other measures as well. Instead of HR, the heart rate parameter may be heart rate variance, for instance. Instead of TCRT, any other vector measure characterizing the relation of the R and T waves in the multidimensional ECG data may be used as well. The method in Figure 4 may be carried out online. The device(s) carrying out the method may include at least one element of a group comprising a processor usable is an electric device, a performance monitor, a mobile station, an external computer, and an exercise device. Instead of or in addition to the online mode of the method, except for the measurement of the multidimensional ECG data, the method may be applied after the exercise. That is, the ECG data may be stored in a memory from which it may be read and analyzed after the exercise.

[0052] Figure 5 shows an embodiment of an apparatus. In the figure, a person 500 who may carry out a fitness exercise is shown. In conjunction with the exercise, a multidimensional ECG may be measured from the person 500. To measure the multidimensional ECG, at least three measuring electrodes are positioned on the person. The at least three electrodes enable ECG measurement on at least two spatially separated couplings. The at least two ECG signal components measured by the coupling may be combined to multidimensional ECG data. The electrode belt 502 may provide some or all of the electrodes. Alternatively or additionally to the electrode belt, some electrodes may be positioned on the back or the shoulder of the person, for instance.

[0053] The person may carry a wrist-worn receiver unit 504. Construction of the multidimensional ECG and a vector measure on the basis of the multidimensional ECG may be carried out in the electrode belt or in the receiver unit 504, for instance. The performance monitor may also apply the vectorcardiographic measure in determining a value of a fitness-exercise-related parameter. In an embodiment, instructions relating to the suitability of the exercising level may be provided to the person.

[0054] Alternatively to the two-piece performance monitor of Figure 5 including the electrode belt 502 and the wrist-worn device 504, the functionality may be implemented in a one-piece performance monitor as well. The electrode belt 502 on the chest, for instance, may carry out all the needed functionality.

[0055] Figure 5 also shows an external computer 510, which may receive the heart rate data from the performance monitor. In the heart rate data, the spatially separately measured ECG components may coexist or the data may be in multidimensional ECG format. The data may be received online during the exercise or may be stored during the exercise on the performance monitor and transferred afterwards to the computer 510. Wired or wireless data transmission may be applied between the performance monitor and the computer 510.

[0056] The computer 510 may include a display 512, a processing unit 514, a data storage unit 516 and a communication unit 518 for communicating with the performance monitor worn by the user.

[0057] If the computer 510 is used in the online mode, it may be operated by a coach of the exercising person, for instance. The computer 510 may plot parameters, such as a value of the vector measure and/or the heart rate of the person on the screen 512. The computer may provide instructions to the coach or the exercising person of how the exercise should be carried on. The instruction may be, for instance, that "the current exercising level is appropriate" or that "the current exercising level is too high". These indications may be provided by the computer or the performance monitor, by using sound and/or visual indication.

[0058] The computer 510 in Figure 5 may be situated in an exercising device, such as a treadmill, for instance. The performance monitor used by the person may in such a case be equipped with communication equipment/functionality to communicate with the treadmill. The instructions to the user may in that case be given by the treadmill or by the performance monitor.

[0059] The computer 510 may also be used in a pre-exercise or post-exercise mode. In the pre-exercise mode, the resting heart rate of the person may be compared with the vectorcardiographic measure and a suitable level of the exercise may be determined. In the post-exercise mode, the performance monitor may store the spatially separately measured ECG data during the exercise. The data may be transferred after the exercise to the computer, where it may be analyzed. The analysis may be visual analysis, for instance, where the display of the computer 510 shows analysis of the relationship of the vector measure and the heart rate of the person during the exercise, and draws conclusions on the suitability of the exercise level of the person during the exercise.

[0060] Figure 5 also shows a mobile station 520, which may be wirelessly connected to the performance monitor 504. The mobile station may receive the ECG data from the performance monitor 504 and communicate the data via a data network 522, such as the Internet, to an external server computer 524. Similarly to the computer 510, the server computer 524 may be connected to the performance monitor online or before/after the exercise for controlling and/or monitoring the exercise performed by the person.

[0061] In addition or alternatively to the heart rate, some other heart rate parameter, such as heart rate variance, or the activity of the person may be determined. A GPS (Global Positioning System) receiver 506 may receive GPS signals for determining the position of the person 500. Movement of the person may then be determined from the changes in the person's position in time. Movement of the person may also be determined by using a foot pod 508, which calculates the distance walked/run on the basis of the steps taken by the person. Furthermore, an activity monitor 509 may be provided to measure the activity of the person.

[0062] Data from one or more of the devices 504, 506, 509 shown may be used to determine the exertion level of the person. This exertion level may be compared to the vector measure and applied in determination of a fitness-exercise-related parameter.

[0063] Therefore, it is clear that the embodiments can be carried out in various devices. To list some embodiments provided by Figure 5, at least the following ones may be identified. All the functionality may be provided in the performance monitor, one-piece or two-piece, online. In another embodiment, the performance monitor is used in a pre-exercise mode to determine a suitable level of exercise. Alternatively, the performance monitor is applied in a post-exercise mode. In such a case, the performance monitor stores the heart rate data during the exercise and provides the functionality to analyze the data afterwards.

[0064] The combination of the performance monitor and the external computer 510 and/or the server computer 524 may be applied online or in a post-exercise mode as explained above. Here it may be noted that in an embodiment, the performance monitor used by the person includes only the electrode belt. The electrode belt 502 may measure the ECG signal from the person and send the heart rate information to the computer 510, or to the mobile station 520. The computer 510 or the server 524 may then prepare and provide the control information to control the exercise.

[0065] Figure 6 shows another embodiment of an apparatus. As will be explained in the following, the apparatus of Figure 6 may be placed in a single device or distributed over several devices.

[0066] The apparatus includes means 602 to 612 for measuring a first ECG component. The electrodes 602, 604 measure a potential difference caused by electrical activation of the person's heart on the person's body. The signal is applied to an ECG preamplifier 606, and may be filtered, after which the heart rate may be calculated. A signal illustrative of the heart rate signal may be amplified in the amplifier 610 before its transmission. Figure 6 also shows a connecting line from the ECG preamplifier 606 to the transmitter unit 612. That is, the ECG signal may also be transmitted as raw data.

[0067] The apparatus also includes second means 622 to 632 for measuring a second ECG component. The functionality of the components 622 to 632 correspond to the respective components 602 to 612. The measurement carried out by the electrodes 622, 624 is spatially separated from the measurement carried out by the electrodes 602 to 604. That is, at least one of the electrodes 622, 624 is different from the electrodes 602 and 604.

[0068] The transmitters 612 and 632 may transmit the ECG signal components to a receiver 640. Wired or wireless transmission may be applied in the transmission. The wireless transmission may be inductive or radio transmission, for instance.

[0069] The apparatus may include a receiver 640 for receiving the first and second ECG components and/or the associated heart rate data. Identifiers may be associated with each ECG component such that they are identified in the receiver 640.

[0070] The signal may be filtered and amplified in the amplifier 642 before forwarding it to a central processor 644, which coordinates the operation of different entities of the receiver.

[0071] The device may include a user interface 646. The user interface 646 may include a display for displaying data relevant to operating the device. With regard to a fitness exercise, the display may display the heart rate and/or the heart rate variation of the person, a value of a vectorcardiographic measure and interpretation of the relationship between the heart rate and the vectorcardiographic measure, for instance. The user interface 646 may also include a keyboard. The person may select, by using the keyboard, a mode of the device, in which the vectorcardiographic measure is formed and applied in determining a fitness-exercise-related parameter.

[0072] The user interface 646 may further include a sound device. The sound device may provide a sound indication

when the person's exercise level is appropriate or needs adjustment.

[0073] The device may also include an interface module 650, which may receive data via a receive module 652 or transmit data via a transmit module 654. Via these interface modules 652, 654 the device may communicate with further devices. For instance, if the devices 602 to 654 belong to a wrist-worn performance monitor, the external interfaces may be applied for exchanging data with an external computer, an exercising device, a mobile station or a server computer, for instance.

[0074] The device may further include a fitness exercise module 660, which may include following functional entities. A module 662 for processing a first ECG component and a module for processing a second ECG component 664 may be provided. The module 666 may combine the ECG signal components from the modules for processing the first and second ECG components 662, 664 to multidimensional ECG data.

[0075] The RT module 668 may extract the R and T wave components from the multidimensional ECG data and form a vector representation of each. Each of the R and T wave components may represent the wave in an orthogonal three-dimensional coordinate system over a time window. The representation may be averaged over time.

[0076] The unit 670 forms a vectorcardiographic measure 670 characterizing a relationship between the R and T vectors. The vectorcardiographic measure may be the angle between the R and T vectors, or a TCRT measure, for instance.

[0077] A heart rate unit 672 may calculate the heart rate of the user by using one or more of the ECG components.

[0078] The instruction module 674 may provide instructions to be given to the user for carrying out the exercise. The instructions may be formed on the basis of the vectorcardiographic measure alone or the vectorcardiographic measure and the heart rate together. A lookup table or a calculation algorithm may be used to determine the appropriate instruction.

[0079] With regard to the device implementation, several alternatives exist for Figure 6.

[0080] In an embodiment, all the functionality is in an electrode belt.

[0081] In another embodiment, the functionality is distributed between the electrode belt and the wrist-worn device of the performance monitor. The electrode belt may transmit the ECG components to the wrist-worn device, which may be responsible for further processing of the data. Alternatively, the electrode belt may form the multidimensional ECG data and transmit it to the wrist-worn device for further processing. Alternatively, the electrode belt may form the vector measure, and transmit information thereon to the wrist-worn device for applying in controlling the exercise.

[0082] Alternatively, the functionality may be distributed over even more devices. For instance, the data of the ECG components may directly be transmitted to an external device from the performance monitor. Thus, further processing of the ECG component data may be carried out in an external computer, an exercising device or a server computer, for instance.

[0083] A method and a computer program product implementing the method and carrying out the functionality of the apparatus may be provided. The embodiments may be implemented by software, hardware, or a combination thereof. The embodiments may be implemented on one or more devices including a processor, a performance monitor, a mobile station, a computer or an exercise device, for instance.

[0084] The disclosed functionality in various embodiments may be implemented by way of a computer program product encoding a computer program of instructions for executing a computer process of the above-described method. The computer program product may be implemented on a computer program distribution medium. The computer program distribution medium may be any of the known ways of distributing software, such as a computer readable medium, a program storage medium, a record medium, a computer readable memory, a computer readable software distribution package, a computer readable signal, a computer readable telecommunication signal, and a computer readable compressed software package. Alternatively, part of the functionality may be implemented by hardware, such as ASIC (Application Specific Integrated Circuit) or by a combination of hardware and software.

[0085] It will be obvious to a person skilled in the art that, as the technology advances, the inventive concept can be implemented in various ways. The invention and its embodiments are not limited to the examples described above but may vary within the scope of the claims.

Claims

1. A portable arrangement in connection with a fitness exercise of a person, the arrangement comprising:

means for measuring (602, 604, 606, 608, 610, 622, 624, 626, 628, 630) multidimensional electrocardiographic data of the person by at least three measuring electrodes (602, 604, 622, 624; 102, 104, 106, 108) positioned in spatially different positions on the person;

means for processing (666) the multidimensional electrocardiographic data of the person, the multidimensional electrocardiographic data comprising at least two spatially separately measured electrocardiographic signal components; and

means for forming (670) a vectorcardiographic measure on the basis of the multidimensional electrocardiographic data;

characterized in that the portable arrangement further comprises:

5 means for applying (674) the vectorcardiographic measure in determination of a fitness exercise related parameter, the fitness exercise related parameter comprising exercise instructions for the person to carry out the fitness exercise; and

10 means for providing (646, 660, 674) the exercise instructions for the person by using sound and/or visual indication, the exercise instructions indicating at least one of the following: it is appropriate to start the fitness exercise, it is appropriate to continue the fitness exercise, it is not appropriate to start the fitness exercise, it is not appropriate to continue the fitness exercise, it is appropriate to reduce stress of the fitness exercise, an appropriate exercising level of the fitness exercise.

15 **2.** The portable arrangement of claim 1, further comprising:

means for transforming (666) at least a portion of the multidimensional electrocardiographic data into an orthogonal representation of the data.

20 **3.** The portable arrangement of claim 1, further comprising:

means for monitoring (672) a heart rate of the person; and
means for determining (674) the fitness-exercise-related parameter on the basis of the heart rate of the person and the vectorcardiographic measure.

25 **4.** The portable arrangement of claim 1, further comprising:

30 means for identifying (668) a multidimensional R wave and a multidimensional T wave from the multidimensional electrocardiographic data; and
means for forming (670), as the vectorcardiographic measure, a relationship between the multidimensional R wave and the multidimensional T wave.

5. The portable arrangement of claim 1, further comprising:

35 means for forming (670) a vector representation characterizing a multidimensional R wave in the electrocardiographic data;
means for forming (670) a vector representation characterizing a multidimensional T wave in the electrocardiographic data; and
means for estimating (670) an angle measure characterizing the angle between the vector representation of the multidimensional R wave and the vector representation of the multidimensional T wave.

40 **6.** The portable arrangement of claim 1, further comprising:

45 means for monitoring (670) if the vectorcardiographic measure exceeds a predetermined threshold value; and
means for providing (674) an indication if the vectorcardiographic measure exceeds a predetermined threshold value.

50 **7.** The portable arrangement of claim 1, wherein the portable arrangement comprises at least one of the following: a processor usable in an electric device, a performance monitor, a mobile station, an external computer, an exercise device.

8. The portable arrangement of claim 1, wherein the exercise instructions are based on conclusions drawn from the vectorcardiographic measure in view of at least one of the following: an exertion level of the person in the fitness exercise, a mental stress of the person, an energy consumption of the person in the fitness exercise, a recovery status of the person, a physical condition parameter of the person, a plasma volume parameter of the person.

55 **9.** The portable arrangement of claim 1, further comprising an operation mode, in which the means for processing multidimensional electrocardiographic data of the person, means for forming a vectorcardiographic measure of the multidimensional electrocardiographic data, and means for applying the vectorcardiographic measure in determi-

nation of a fitness-exercise-related parameter are activated.

10. A method performed in a portable arrangement in connection with a fitness exercise of a person, the method comprising:

5

measuring (402) multidimensional electrocardiographic data of the person by at least three measuring electrodes positioned in spatially different positions on the person;
 processing (404) the multidimensional electrocardiographic data of the person, the multidimensional electrocardiographic data comprising at least two spatially separately measured electrocardiographic signal components; and
 forming (406) a vectorcardiographic measure on the basis of the multidimensional electrocardiographic data;
characterized in that the method further comprises:

10

15

applying (408) the vectorcardiographic measure in determination of a fitness-exercise-related parameter, the fitness exercise related parameter comprising exercise instructions for the person to carry out the fitness exercise; and
 providing the exercise instructions for the person by using sound and/or visual indication, the exercise instructions indicating at least one of the following: it is appropriate to start the fitness exercise, it is appropriate to continue the fitness exercise, it is not appropriate to start the fitness exercise, it is not appropriate to continue the fitness exercise, it is appropriate to reduce stress of the fitness exercise, an appropriate exercising level of the fitness exercise.

20

11. The method of claim 10, further comprising:

25

monitoring a heart rate of the person; and
 determining (408) the fitness-exercise-related parameter on the basis of the heart rate of the person and the vectorcardiographic measure.

12. The method of claim 10, further comprising:

30

identifying (406) a multidimensional R wave and a multidimensional T wave from the multidimensional electrocardiographic data; and
 forming (406), as the vectorcardiographic measure, a relationship between the multidimensional R wave and the multidimensional T wave.

35

13. The method of claim 10, further comprising:

40

monitoring (408) if the vectorcardiographic measure exceeds a predetermined threshold value; and
 providing (408) an indication if the vectorcardiographic measure exceeds the predetermined threshold value.

14. A computer-readable medium comprising a computer program product encoding a computer program of instructions, which, when loaded into a portable arrangement causes the portable arrangement to:

45

measure multidimensional electrocardiographic data of the person by at least three measuring electrodes positioned in spatially different positions on the person;
 process the multidimensional electrocardiographic data of the person, the multidimensional electrocardiographic data comprising at least two spatially separately measured electrocardiographic signal components; and
 form a vectorcardiographic measure on the basis of the multidimensional electrocardiographic data;
characterized by:

50

apply the vectorcardiographic measure in determination of a fitness-exercise-related parameter, the fitness exercise related parameter comprising exercise instructions for the person to carry out the fitness exercise;
 and
 provide the exercise instructions for the person by using sound and/or visual indication, the exercise instructions indicating at least one of the following: it is appropriate to start the fitness exercise, it is appropriate to continue the fitness exercise, it is not appropriate to start the fitness exercise, it is not appropriate to continue the fitness exercise, it is appropriate to reduce stress of the fitness exercise, an appropriate exercising level of the fitness exercise.

55

Patentansprüche

1. Tragbare Anordnung in Zusammenhang mit einer Fitnessübung einer Person, aufweisend:

5 Mittel zur Messung (602, 604, 606, 608, 610, 622, 624, 626, 628, 630) von multidimensionalen elektrokardiographischen Daten der Person durch zumindest drei Messelektroden (602, 604, 622, 624; 102, 104, 106, 108), die in räumlich verschiedenen Positionen an der Person positioniert sind;
Mittel zur Verarbeitung (666) der multidimensionalen elektrokardiographischen Daten der Person, welche multidimensionalen elektrokardiographischen Daten zumindest zwei räumlich getrennt gemessene elektrokardiographische Signalkomponenten aufweisen; und
10 Mittel zur Ausbildung (670) eines vektorkardiographischen Maßes aufgrund der multidimensionalen elektrokardiographischen Daten;
dadurch gekennzeichnet, dass die tragbare Anordnung ferner aufweist:

15 Mittel zur Anwendung (674) des vektorkardiographischen Maßes auf Bestimmung eines auf die Fitnessübung bezogenen Parameters, welcher auf die Fitnessübung bezogene Parameter Übungsanleitungen für die Person zur Durchführung der Fitnessübung aufweist; und
Mittel zur Bereitstellung (646, 660, 674) der Übungsanleitungen für die Person mittels einer Ton- und/oder visuellen Anzeige, welche Übungsanleitungen zumindest eines der folgenden anzeigen: es ist angebracht, die Fitnessübung anzufangen, es ist angebracht, die Fitnessübung fortzusetzen, es ist nicht angebracht, die Fitnessübung anzufangen, es ist nicht angebracht, die Fitnessübung fortzusetzen, es ist angebracht, die Belastung der Fitnessübung zu verringern, ein passendes Übungsniveau der Fitnessübung.

2. Tragbare Anordnung nach Patentanspruch 1, aufweisend ferner:

25 Mittel zur Umwandlung (666) zumindest eines Teils der multidimensionalen elektrokardiographischen Daten in eine orthogonale Darstellung der Daten.

3. Tragbare Anordnung nach Patentanspruch 1, aufweisend ferner:

30 Mittel zur Überwachung (672) einer Herzfrequenz der Person; und
Mittel zur Bestimmung (674) des auf die Fitnessübung bezogenen Parameters aufgrund der Herzfrequenz der Person und des vektorkardiographischen Maßes.

4. Tragbare Anordnung nach Patentanspruch 1, aufweisend ferner:

35 Mittel zur Identifizierung (668) einer multidimensionalen R-Zacke und einer multidimensionalen T-Zacke aus den multidimensionalen elektrokardiographischen Daten; und
Mittel zur Ausbildung (670) eines Verhältnisses zwischen der multidimensionalen R-Zacke und der multidimensionalen T-Zacke als vektorkardiographisches Maß.

5. Tragbare Anordnung nach Patentanspruch 1, aufweisend ferner:

45 Mittel zur Ausbildung (670) einer Vektordarstellung, die eine multidimensionale R-Zacke in den elektrokardiographischen Daten charakterisiert;
Mittel zur Ausbildung (670) einer Vektordarstellung, die eine multidimensionale T-Zacke in den elektrokardiographischen Daten charakterisiert; und
Mittel zur Schätzung (670) eines Winkelmaßes, das den Winkel zwischen der Vektordarstellung der multidimensionalen R-Zacke und der Vektordarstellung der multidimensionalen T-Zacke charakterisiert.

6. Tragbare Anordnung nach Patentanspruch 1, aufweisend ferner:

50 Mittel zur Überwachung (670), ob das vektorkardiographische Maß einen vorbestimmten Grenzwert überschreitet; und
55 Mittel zum Geben (674) eines Anzeichens, falls das vektorkardiographische Maß einen vorbestimmten Grenzwert überschreitet.

7. Tragbare Anordnung nach Patentanspruch 1, wobei die tragbare Anordnung zumindest eines der folgenden aufweist:

einen in einem elektrischen Gerät anwendbaren Prozessor, einen Leistungsmonitor, eine Mobilstation, einen externen Computer, ein Übungsgerät.

5 8. Tragbare Anordnung nach Patentanspruch 1, wobei die Übungsanleitungen auf Schlussfolgerungen basieren, die aus dem vektorkardiographischen Maß im Hinblick auf zumindest eines der folgenden gezogen werden: Anstrengungsniveau der Person in der Fitnessübung, psychische Belastung der Person, Energieverbrauch der Person in der Fitnessübung, Erholungsstatus der Person, Parameter für die physikalische Kondition der Person, Parameter für das Plasmavolumen der Person.

10 9. Tragbare Anordnung nach Patentanspruch 1, die ferner einen Betriebsmodus aufweist, in dem die Mittel zur Verarbeitung von multidimensionalen elektrokardiographischen Daten der Person, die Mittel zur Ausbildung eines vektorkardiographischen Maßes aus den multidimensionalen elektrokardiographischen Daten und die Mittel zur Anwendung des vektorkardiographischen Maßes auf Bestimmung eines auf die Fitnessübung bezogenen Parameters aktiviert werden.

15 10. In einer tragbaren Anordnung durchzuführendes Verfahren in Zusammenhang mit einer Fitnessübung einer Person, bei welchem Verfahren:

20 multidimensionale elektrokardiographische Daten der Person durch zumindest drei Messelektroden, die in räumlich verschiedenen Positionen an der Person positioniert sind, gemessen werden (402); die multidimensionalen elektrokardiographischen Daten der Person verarbeitet werden (404), welche multidimensionalen elektrokardiographischen Daten zumindest zwei räumlich getrennt gemessene elektrokardiographische Signalkomponenten aufweisen; und

25 ein vektorkardiographisches Maß aufgrund der multidimensionalen elektrokardiographischen Daten ausgebildet wird (406);

dadurch gekennzeichnet, dass bei dem Verfahren ferner:

30 das vektorkardiographische Maß auf Bestimmung eines auf die Fitnessübung bezogenen Parameters angewandt wird (408), welcher auf die Fitnessübung bezogene Parameter Übungsanleitungen für die Person zur Durchführung der Fitnessübung aufweist; und

35 die Übungsanleitungen für die Person mittels einer Ton- und/oder visuellen Anzeige bereitgestellt werden, welche Übungsanleitungen zumindest eines der folgenden anzeigen: es ist angebracht, die Fitnessübung anzufangen, es ist angebracht, die Fitnessübung fortzusetzen, es ist nicht angebracht, die Fitnessübung anzufangen, es ist nicht angebracht, die Fitnessübung fortzusetzen, es ist angebracht, die Belastung der Fitnessübung zu verringern, ein passendes Übungsniveau der Fitnessübung.

11. Verfahren nach Patentanspruch 10, bei welchem ferner:

40 eine Herzfrequenz der Person überwacht wird; und der auf die Fitnessübung bezogene Parameter aufgrund der Herzfrequenz der Person und des vektorkardiographischen Maßes bestimmt wird (408).

12. Verfahren nach Patentanspruch 10, bei welchem ferner:

45 eine multidimensionale R-Zacke und eine multidimensionale T-Zacke aus den multidimensionalen elektrokardiographischen Daten identifiziert werden (406); und als vektorkardiographisches Maß ein Verhältnis zwischen der multidimensionalen R-Zacke und der multidimensionalen T-Zacke ausgebildet wird (406).

50 13. Verfahren nach Patentanspruch 10, bei welchem ferner:

überwacht wird (408), ob das vektorkardiographische Maß einen vorbestimmten Grenzwert überschreitet; und ein Anzeichen gegeben wird (408), falls das vektorkardiographische Maß einen vorbestimmten Grenzwert überschreitet.

55 14. Computerlesbares Medium, das ein Computerprogrammprodukt aufweist, das ein Computerprogramm von Anweisungen kodiert, das, wenn es in eine tragbare Anordnung geladen ist, die tragbare Anordnung dazu bringt, multidimensionale elektrokardiographische Daten der Person durch zumindest drei Messelektroden, die in räumlich

verschiedenen Positionen an der Person positioniert sind, zu messen;
 die multidimensionalen elektrokardiographischen Daten der Person zu verarbeiten, welche multidimensionalen elektrokardiographischen Daten zumindest zwei räumlich getrennt gemessene elektrokardiographische Signalkomponenten aufweisen; und
 ein vektorkardiographisches Maß aufgrund der multidimensionalen elektrokardiographischen Daten auszubilden;
dadurch gekennzeichnet, dass
 das vektorkardiographische Maß auf Bestimmung eines auf die Fitnessübung bezogenen Parameters angewandt wird, welcher auf die Fitnessübung bezogene Parameter Übungsanleitungen für die Person zur Durchführung der Fitnessübung aufweist; und
 die Übungsanleitungen für die Person mittels einer Ton- und/oder visuellen Anzeige bereitgestellt werden, welche Übungsanleitungen zumindest eines der folgenden anzeigen: es ist angebracht, die Fitnessübung anzufangen, es ist angebracht, die Fitnessübung fortzusetzen, es ist nicht angebracht, die Fitnessübung anzufangen, es ist nicht angebracht, die Fitnessübung fortzusetzen, es ist angebracht, die Belastung der Fitnessübung zu verringern, ein passendes Übungsniveau der Fitnessübung.

Revendications

1. Dispositif portatif en connexion avec un exercice de fitness d'une personne, ce dispositif comprenant :

un moyen pour la mesure (602, 604, 606, 608, 610, 622, 624, 626, 628, 630) de données électrocardiographiques multidimensionnelles de la personne par au moins trois électrodes de mesure (602, 604, 622, 624 ; 102, 104, 106, 108) positionnées dans des positions spatialement différentes de la personne ;

un moyen pour le traitement (666) des données électrocardiographiques multidimensionnelles de la personne, les données électrocardiographiques multidimensionnelles comprenant au moins deux composantes de signaux électrocardiographiques mesurées séparément spatialement ; et

un moyen pour former (670) une mesure vectorielle cardiographique sur la base des données électrocardiographiques multidimensionnelles ;

caractérisé en ce que le dispositif portatif comprend en outre :

un moyen pour appliquer (674) la mesure vectorielle cardiographique à la détermination d'un paramètre lié à un exercice de fitness, le paramètre lié à un exercice de fitness comprenant des instructions d'exercice pour que la personne effectue l'exercice de fitness ; et

un moyen pour fournir (646, 660, 674) les instructions d'exercice à la personne en utilisant des indications sonores et/ou visuelles, les instructions d'exercice indiquant au moins un élément parmi ce qui suit : il est approprié de commencer l'exercice de fitness, il est approprié de continuer l'exercice de fitness, il n'est pas approprié de commencer l'exercice de fitness, il n'est pas approprié de continuer l'exercice de fitness, il est approprié de réduire la tension de l'exercice de fitness, un niveau d'exercice approprié de l'exercice de fitness.

2. Dispositif portatif selon la revendication 1, comprenant en outre :

un moyen pour transformer (666) au moins une portion des données électrocardiographiques multidimensionnelles en une représentation orthogonale des données.

3. Dispositif portatif selon la revendication 1, comprenant en outre :

un moyen pour surveiller (672) un rythme cardiaque de la personne ; et

un moyen pour déterminer (674) le paramètre lié à l'exercice de fitness sur la base du rythme cardiaque de la personne et la mesure vectorielle cardiographique.

4. Dispositif portatif selon la revendication 1, comprenant en outre :

un moyen pour identifier (668) une onde multidimensionnelle R et une onde multidimensionnelle T dans les données électrocardiographiques multidimensionnelles ; et

un moyen pour former (670), en tant que mesure vectorielle cardiographique, une relation entre l'onde multidimensionnelle R et l'onde multidimensionnelle T.

5. Dispositif portatif selon la revendication 1, comprenant en outre :

un moyen pour former (670) une représentation vectorielle caractérisant une onde multidimensionnelle R dans les données électrocardiographiques ;
un moyen pour former (670) une représentation vectorielle caractérisant une onde multidimensionnelle T dans les données électrocardiographiques ; et
un moyen pour estimer (670) une mesure d'angle caractérisant l'angle entre la représentation vectorielle de l'onde multidimensionnelle R et la représentation vectorielle de l'onde multidimensionnelle T.

6. Dispositif portatif selon la revendication 1, comprenant en outre :

un moyen pour surveiller (670) si la mesure vectorielle cardiographique dépasse une valeur seuil prédéterminée ;
et
un moyen pour fournir (674) une indication si la mesure vectorielle cardiographique dépasse une valeur seuil prédéterminée.

7. Dispositif portatif selon la revendication 1, dans lequel le dispositif portatif comprend au moins un élément parmi ce qui suit : un processeur utilisable dans un dispositif électrique ; un moniteur de performances, une station mobile, un ordinateur externe, un dispositif d'exercice.

8. Dispositif portatif selon la revendication 1, dans lequel les instructions d'exercice sont basées sur les conclusions tirées de la mesure vectorielle cardiographique en vue d'au moins un élément parmi ce qui suit : un niveau d'exercice de la personne dans l'exercice de fitness, un stress mental de la personne, une consommation d'énergie de la personne dans l'exercice de fitness, un état de récupération de la personne, un paramètre de condition physique de la personne, un paramètre de volume de plasma de la personne.

9. Dispositif portatif selon la revendication 1, comprenant en outre un mode de fonctionnement dans lequel le moyen pour le traitement des données électrocardiographiques multidimensionnelles de la personne, le moyen pour former une mesure vectorielle cardiographique des données électrocardiographiques multidimensionnelles et le moyen pour appliquer la mesure vectorielle cardiographique à la détermination d'un paramètre d'exercice de fitness sont activés.

10. Procédé mis en oeuvre dans un dispositif portatif en connexion avec un exercice de fitness d'une personne, ce procédé comprenant :

la mesure (402) de données électrocardiographiques multidimensionnelles de la personne par au moins trois électrodes de mesure positionnées dans des positions spatialement différentes de la personne ;
le traitement (404) des données électrocardiographiques multidimensionnelles de la personne, les données électrocardiographiques multidimensionnelles comprenant au moins deux composantes de signaux électrocardiographiques mesurées séparément spatialement ; et
la formation (406) d'une mesure vectorielle cardiographique sur la base des données électrocardiographiques multidimensionnelles ;
caractérisé en ce que le procédé comprend en outre :

l'application (408) de la mesure vectorielle cardiographique à la détermination d'un paramètre lié à l'exercice de fitness, le paramètre lié à l'exercice de fitness comprenant des instructions d'exercice pour que la personne effectue l'exercice de fitness ; et
la fourniture des instructions d'exercice à la personne en utilisant des indications sonores et/ou visuelles, les instructions d'exercice indiquant au moins un élément parmi les suivants : il est approprié de commencer l'exercice de fitness, il est approprié de continuer l'exercice de fitness, il n'est pas approprié de commencer l'exercice de fitness, il n'est pas approprié de continuer l'exercice de fitness, il est approprié de réduire la tension de l'exercice de fitness, un niveau d'exercice approprié pour l'exercice de fitness.

11. Procédé selon la revendication 10, comprenant en outre :

la surveillance d'un rythme cardiaque ; et
la détermination (408) du paramètre lié à l'exercice sur la base du rythme cardiaque de la personne et de la mesure vectorielle cardiographique.

12. Procédé selon la revendication 10, comprenant en outre :

5 l'identification (406) d'une onde multidimensionnelle R et d'une onde multidimensionnelle T dans les données électrocardiographiques multidimensionnelles ; et
la formation (406), en tant que mesure vectorielle cardiographique, d'une relation entre l'onde multidimensionnelle R et l'onde multidimensionnelle T.

13. Procédé selon la revendication 10, comprenant en outre :

10 la surveillance (408) si la mesure vectorielle cardiographique dépasse une valeur seuil prédéterminée ; et
la fourniture (408) d'une indication si la mesure vectorielle cardiographique dépasse la valeur seuil prédéterminée.

14. Support lisible par ordinateur comprenant un produit de programme informatique codant un programme informatique d'instructions qui, lorsqu'il est chargé dans un dispositif portable, fait en sorte que le dispositif portable :

15 mesure les données électrocardiographiques multidimensionnelles de la personne par au moins trois électrodes de mesure positionnées dans les positions spatialement différentes sur la personne ;
20 traite les données électrocardiographiques multidimensionnelles de la personne, les données électrocardiographiques multidimensionnelles comprenant au moins deux composantes de signaux électrocardiographiques mesurées séparément spatialement ; et
forme une mesure vectorielle cardiographique sur la base des données électrocardiographiques multidimensionnelles ;

25 **caractérisé par :**

l'application de la mesure vectorielle cardiographique à la détermination d'un paramètre lié à l'exercice de fitness, le paramètre lié à l'exercice de fitness comprenant des instructions d'exercice pour que la personne effectue l'exercice de fitness ; et
30 la fourniture des instructions d'exercice à la personne en utilisant des indications sonores et/ou visuelles, les instructions d'exercice indiquant au moins un élément parmi ce qui suit : il est approprié de commencer l'exercice, il est approprié de continuer l'exercice, il n'est pas approprié de commencer l'exercice de fitness, il n'est pas approprié de continuer l'exercice de fitness, il est approprié de réduire la tension de l'exercice de fitness, un niveau d'exercice approprié de l'exercice de fitness.

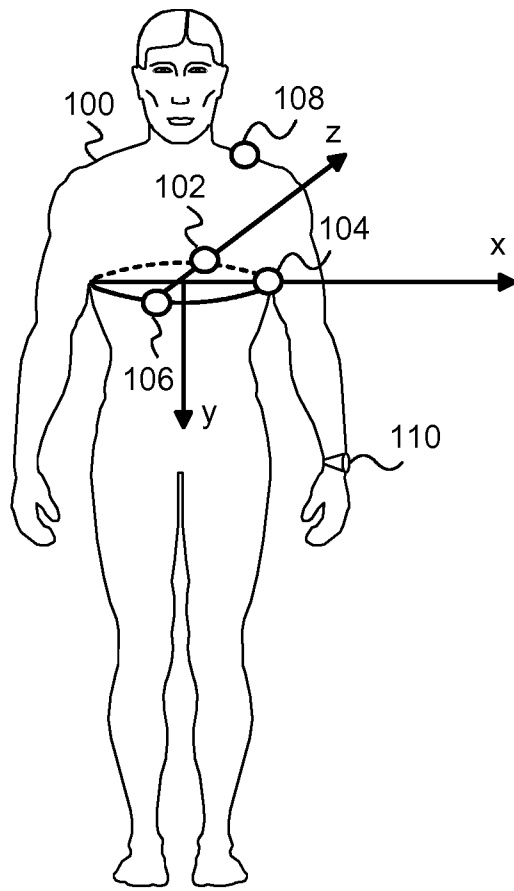

Fig. 1

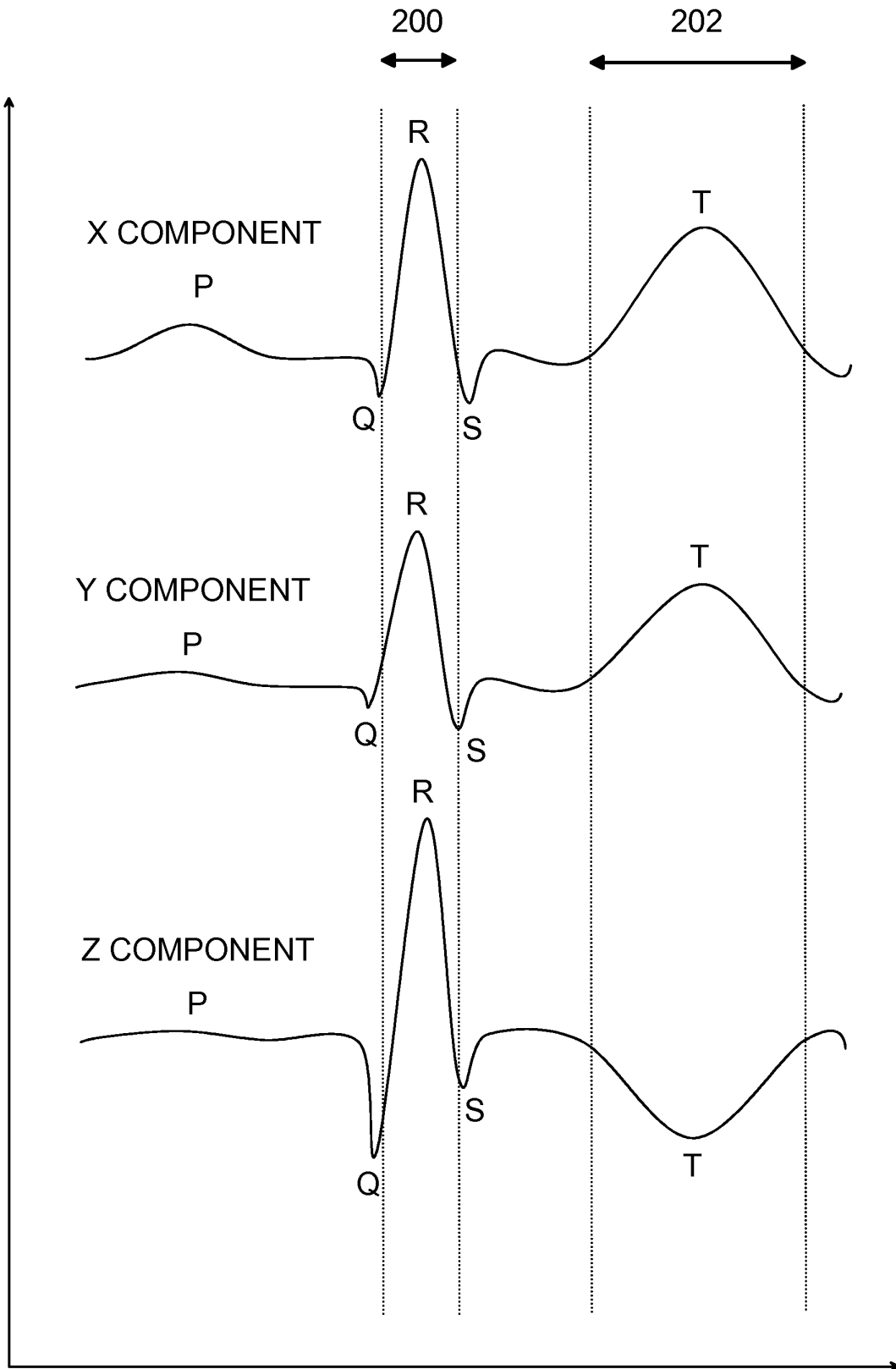

Fig. 2

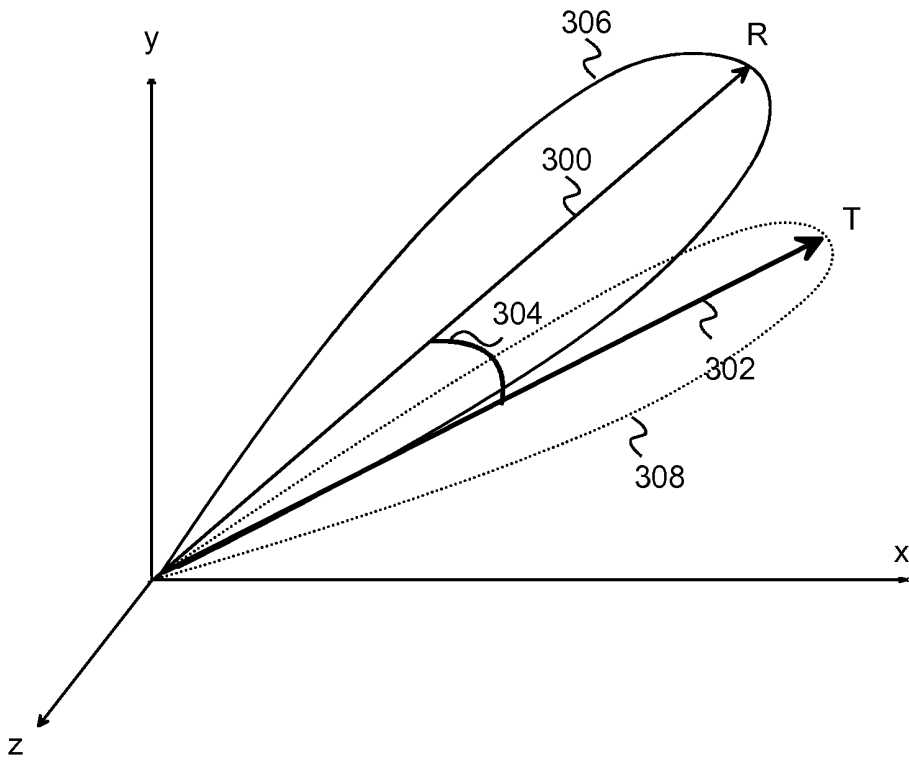

Fig. 3

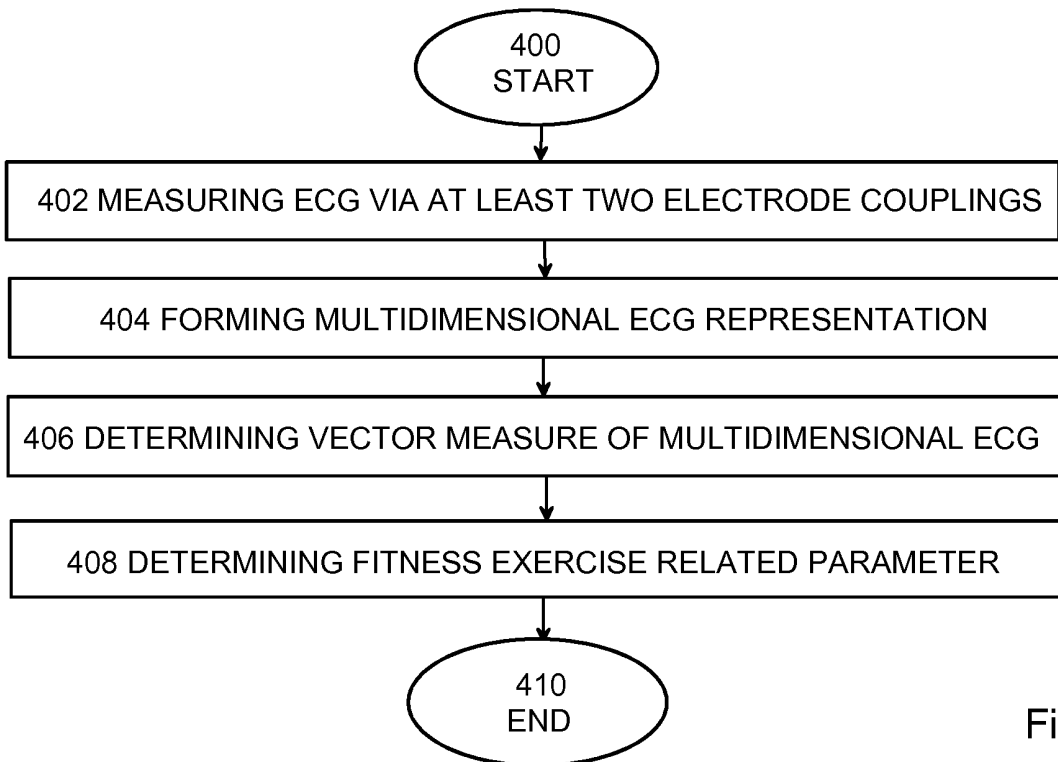

Fig.4

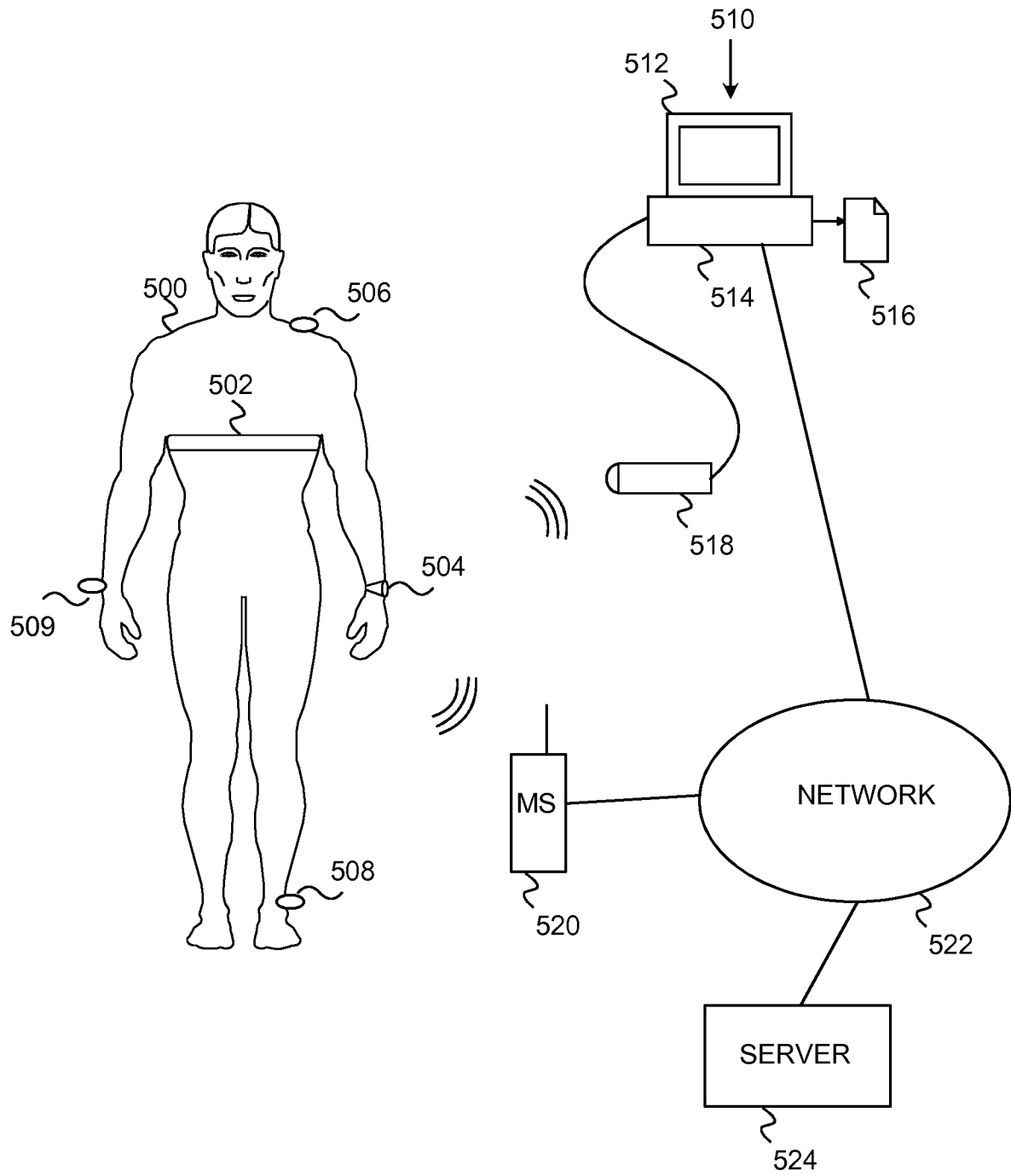

Fig. 5

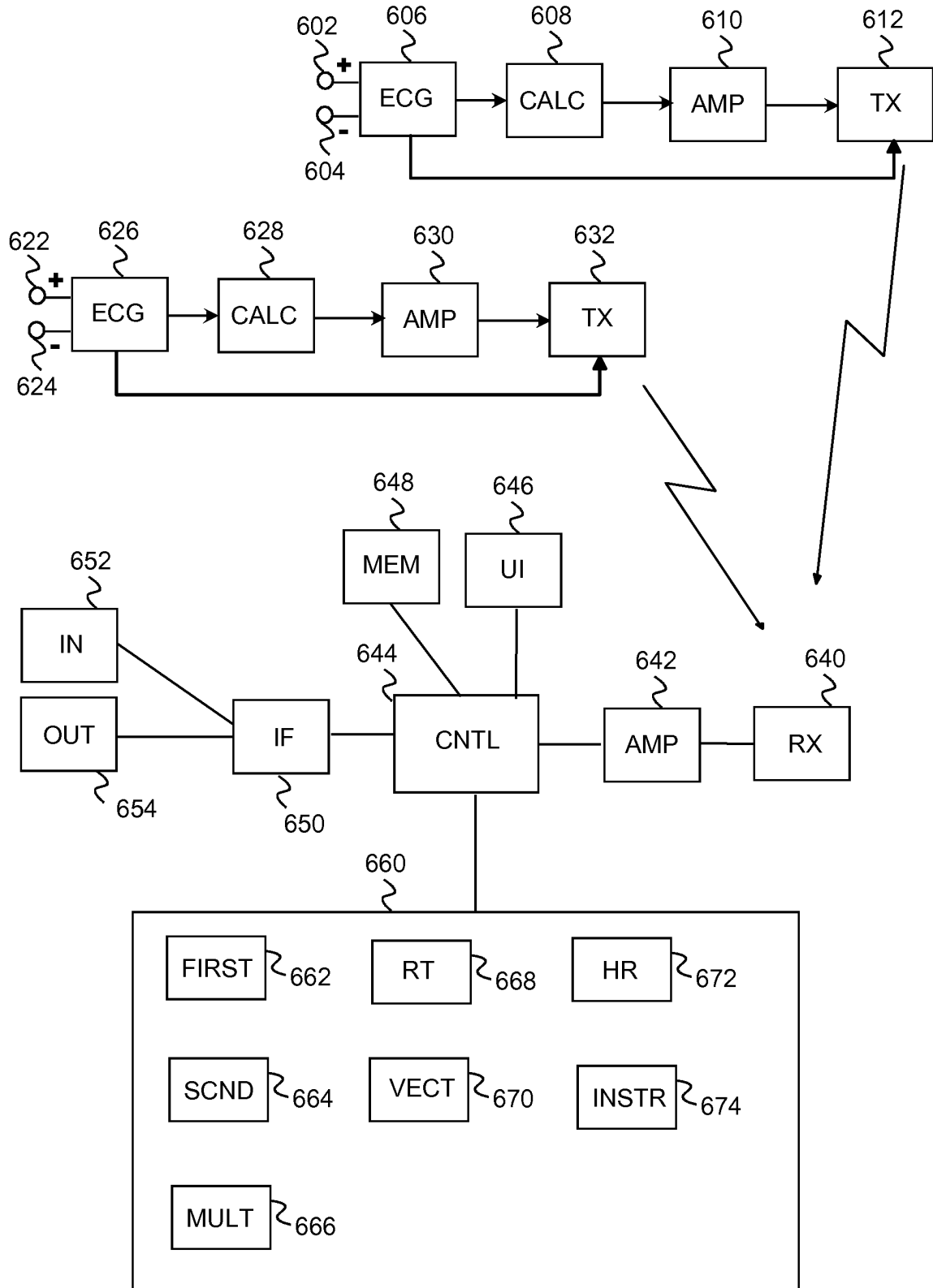

Fig. 6

REFERENCES CITED IN THE DESCRIPTION

This list of references cited by the applicant is for the reader's convenience only. It does not form part of the European patent document. Even though great care has been taken in compiling the references, errors or omissions cannot be excluded and the EPO disclaims all liability in this regard.

Patent documents cited in the description

- EP 1852062 A [0006]
- EP 1133950 A [0007]

Non-patent literature cited in the description

- **KIYOSHI WATANABE et al.** The relationship between exercise-induced R wave amplitude changes and QRS vector loops. *Journal of Electrocardiology*, January 1981, vol. 14 (2), 129-138 [0004]
- **JAN A KORS et al.** Spatial QRS-T angle as a risk indicator of cardiac death in an elderly population. *Journal of Electrocardiology*, 01 December 2003, vol. 36, 113-114 [0005]

专利名称(译)	与锻炼有关的方法和设备		
公开(公告)号	EP2296540B1	公开(公告)日	2016-10-26
申请号	EP2008761714	申请日	2008-06-02
[标]申请(专利权)人(译)	博能电子公司		
申请(专利权)人(译)	Polar Electro Oy公司		
当前申请(专利权)人(译)	Polar Electro Oy公司		
[标]发明人	KINNUNEN HANNU		
发明人	KINNUNEN, HANNU		
IPC分类号	A61B5/04 A61B5/0402 A61B5/00 A63B24/00 A61B5/024		
CPC分类号	A61B5/04011 A61B5/02438 A61B5/6831 A61B2503/10 A63B24/0062 A63B2230/04		
代理机构(译)	KOLSTER OY AB		
其他公开文献	EP2296540A4 EP2296540A1		
外部链接	Espacenet		

摘要(译)

一种与人的健身运动相关的装置，包括用于处理人的多维心电图数据的装置，该多维心电图数据包括至少两个空间上分开测量的心电图信号分量，用于基于多维形成矢量心电图测量的装置心电图数据，以及用于在确定健身运动相关参数时应用矢量心电图测量的装置。

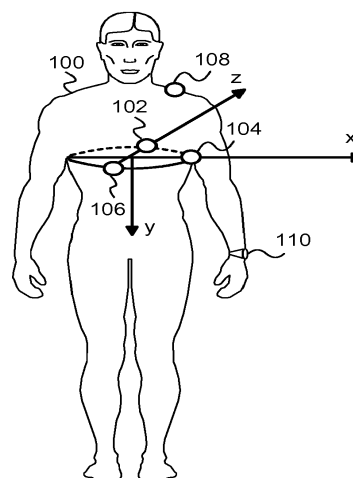

Fig. 1