

(19)



(11)

**EP 1 768 546 B1**

(12)

**EUROPEAN PATENT SPECIFICATION**

(45) Date of publication and mention of the grant of the patent:

**13.04.2016 Bulletin 2016/15**

(21) Application number: **05713646.7**

(22) Date of filing: **16.02.2005**

(51) Int Cl.:

**A61B 5/00 (2006.01)**

(86) International application number:

**PCT/US2005/004884**

(87) International publication number:

**WO 2006/009585 (26.01.2006 Gazette 2006/04)**

(54) **MEDICAL BODY CORE THERMOMETER**

MEDIZINISCHES KÖRPERKERN-THERMOMETER

THERMOMÈTRE DE COEUR DE CORPS MÉDICAL

(84) Designated Contracting States:

**AT BE BG CH CY CZ DE DK EE ES FI FR GB GR  
HU IE IS IT LI LT LU MC NL PL PT RO SE SI SK TR**

(30) Priority: **18.06.2004 US 870654**

(43) Date of publication of application:

**04.04.2007 Bulletin 2007/14**

(73) Proprietor: **KAZ, INC.**

**Southborough, MA 01772 (US)**

(72) Inventor: **FRADEN, Jacob**

**San Diego, CA 92122 (US)**

(74) Representative: **Findlay, Alice Rosemary et al**

**Reddie & Grose LLP**

**16 Theobalds Road**

**London WC1X 8PL (GB)**

(56) References cited:

**EP-A- 0 747 682**

**WO-A-96/19938**

**DE-A1- 2 913 048**

**US-A- 3 570 312**

**US-A- 3 832 902**

**US-A- 5 050 612**

**US-A- 5 893 833**

**US-A1- 2001 044 588**

**US-B1- 6 292 685**

**US-B2- 6 499 877**

**US-B2- 6 830 549**

**EP 1 768 546 B1**

Note: Within nine months of the publication of the mention of the grant of the European patent in the European Patent Bulletin, any person may give notice to the European Patent Office of opposition to that patent, in accordance with the Implementing Regulations. Notice of opposition shall not be deemed to have been filed until the opposition fee has been paid. (Art. 99(1) European Patent Convention).

**Description****Field of Invention**

5 **[0001]** This invention relates to medical thermometers. More particularly, the invention relates to thermometers that determine core body temperature.

**Background of the Invention**

10 **[0002]** Body temperature is universally accepted as an important indicator of the physical condition of humans and other warm blooded animals. For many years, the most common method of measuring body temperature was to insert a contact type thermometer into the patient's mouth or rectum relying on conduction of heat to register an accurate temperature. One such thermometer is a mercury-in-glass thermometer. These thermometers are potentially hazardous due to a possibility of a mercury spill and glass breakage. An alternative contact type thermometer is an electronic "pencil" thermometer. These traditional thermometers will not register a body temperature until after they are left in the patient's mouth, rectum or other location for a relatively long time, thus making the measurement slow and uncomfortable.

15 **[0003]** A more advanced instrumentation has been developed for measuring the human body temperature by non-contact readings of the infrared (IR) emissions from the tympanic membrane and the ear canal. That is, the IR sensor element takes a reading without the sensor or associated sensing elements having to contact the patient. This technology has been the subject of patents to O'Hara et al. (U.S. Patent No. 4,790, 324) and Fraden (U.S. Patent No. 4,854,730). The determination of body temperature from an IR reading of the ear drum or ear canal avoids a need of insertion of a probe into a mouth or rectum and allows a measurement of body temperature within a few seconds. However, the IR thermometers have their own problems, the most important of which is susceptibility to the operator's technique of taking a temperature. Other drawbacks include effects of ambient temperature and sensitivity to cleanliness of the IR lens. The IR thermometers are also relatively expensive.

20 **[0004]** Another IR thermometer, which is exemplified by U.S. Publication No. 200210114375 by Pompei, describes estimation of a core temperature by measuring the skin temperature and the ambient temperature by use of an IR emission detector. This method, however, suffers from other limitations, including an operator's technique, higher cost and other factors.

25 **[0005]** Any traditional contact (non-IR) thermometer has a probe with a temperature sensor that responds to temperature of an object, i.e., a thermal temperature sensor. The rate of response depends on the degree of a thermal coupling with the object, nature of an object, the sensor's isolation from other components and its thermal capacity. There are two known techniques in the art of contact thermometry. One is the equilibrium and the other is the predictive technique. The equilibrium demands a sufficiently long time to allow the sensor to stabilize its response, meaning that the sensors temperature and the object's temperature become nearly equal. The predictive technique is based on measuring the rate of the sensor's response and estimation of its would be equilibrium level which is not actually achieved during the measurement but rather anticipated mathematically. The latter technique allows a much quicker measurement but can result in some loss in accuracy. The predictive method is exemplified by U.S. Patent No. 3,978,325. Some of the predictive techniques rely on a software data processing, while others rely on a hardware design. For instance, U.S. Patent 30 3,872,726 issued to Kauffeld et al. teaches forecasting the ultimate temperature of a slow responding thermistor in a contact thermometer by using a hardware integrator. These thermometers are still intended for insertion into a body orifice.

35 **[0006]** It is therefore an object of the present invention to provide an electronic thermometer that can register a core body temperature of a mammal without necessarily being inserted in the mouth or rectum.

40 **[0007]** It is another object of the present invention to provide an electronic thermometer that can register a core or internal body temperature of a warm blooded animal or human patient quickly after contacting the patient's skin.

45 **[0008]** It is another object of the present invention to provide a thermometer that determines core body temperature in a manner that is less dependent on the operator's technique.

**[0009]** It is another object of the invention to provide an inexpensive thermometer which is easy to manufacture.

**[0010]** It is another object of the invention to provide an inexpensive thermometer which is easy to manufacture.

50 **[0011]** Further and additional objects are apparent from the following discussion of the present invention and the preferred embodiment.

**[0012]** WO96/19938 discloses a quick registering thermometer with a sensor mounted on a probe tip which is compliant and allows the sensor to "float".

55 **[0013]** US 3 832 902 teaches a device according to the preamble of claim 1.

**Summary of the Invention**

**[0014]** The present invention provides a temperature sensing device operative to determine the core temperature of

a warm blooded animal or human based on at least one measurement of the temperature of the skin of the warm blooded animal or human, the device comprising a housing, a first contact type temperature sensing element coupled to the housing and including a first temperature sensor, the first temperature sensor operative to measure the temperature of the skin when the first contact type temperature sensing element is in contact with the skin and produce at least a first signal, a moveable element carrying the first contact type temperature sensing element, the moveable element configured to be moved into a first position at which the first contact type temperature sensing element is adapted for contact with the skin, an electronic circuit electrically coupled with the first contact type temperature sensing element and operative to use the first signal to determine the core temperature of the warm blooded animal or human, and an electronic communication device coupled to the electronic circuit and operative to communicate the core temperature to a user, characterized in that the moveable element is configured to be moved into a second position at which the first contact type temperature sensing element is not adapted for contact with the skin, and in that the device further comprises a guard coupled to the housing and configured to surround and protect the first contact type temperature sensing element when not in use, the guard further being moveable relative to the first contact type temperature sensing element to allow the first contact type temperature sensing element to contact the skin while measuring the temperature of the skin.

**[0015]** In a preferred embodiment, a thermal insulator is positioned adjacent the first temperature sensor. Also, a second temperature sensor may be coupled to the housing, the thermal insulator, if provided, is positioned generally between the first and second temperature sensors so as to thermally decouple the first and second temperature sensors from each other. The second temperature sensor is positioned so as to be thermally decoupled from the skin during thermal measurement of the skin with the first temperature sensor and the second temperature sensor detects a reference temperature represented by at least a second signal. The electronic circuit then uses the first and second signals to determine the core temperature.

**[0016]** The moveable element can further comprise a shaft formed from a thermally insulating material, and this shaft may be spring loaded to normally bias the first contact type temperature sensing element toward the first position, that is, out of contact with the skin.

**[0017]** In another embodiment a power supply is coupled to the temperature sensor, and the electronic circuit is electrically coupled to the temperature sensor and the power supply. A handling detector is coupled with the power supply and operates to detect handling of the device by the user and, in response, activate the supply of power from the power supply to the electronic circuit. As examples, the handling detector can further comprise various types of motion sensors, such as tilt detectors, or may be touch sensitive, such as through the use of a capacitive touch sensor. Redundant systems of this type may be used if desired to ensure that the device powers up upon handling by the user. Another possibility is to provide a switch mechanically coupled to the temperature sensor such that, for example, if the sensor or portion carrying the sensor is tapped on a table or counter surface, the device will power up.

**[0018]** There are also disclosed methods for determining the core temperature of a warm blooded animal or human based on at least one measurement of the temperature of the skin of the warm blooded animal or human. Generally, the method involves contacting the skin of the warm blooded animal or human with a first contact type temperature sensing element. The temperature of the skin is then determined based on at least a first signal from the first contact type temperature sensing element. The first signal is then used to determine the core temperature of the warm blooded animal or human.

**[0019]** The method can further involve determining the temperature of the first contact type temperature sensing element prior to determining the temperature of the skin with the first contact type temperature sensing element. At least a second signal is produced representative of the temperature of the first contact type temperature sensing element. The first and second signals are then used to determine the core temperature of the warm blooded animal or human.

**[0020]** In one feature, determining the temperature of the skin further comprises measuring a rate of change in skin temperature readings.

**[0021]** Another feature involves producing at least a second signal representative of the temperature of a second thermal temperature sensor thermally insulated from both the first contact type temperature sensing element and the skin, and using the first and second signals to determine the core temperature of the warm blooded animal or human.

**[0022]** Various additional aspects and features of the invention will become more readily apparent to those of ordinary skill upon review of the following detailed description of the illustrative embodiments.

**Brief Description of Drawings**

**[0023]**

FIG. 1 is a perspective view of a first illustrative embodiment of a thermometer in accordance with the invention and shown with a probe touching the skin of the patient's forehead.

FIG. 2 is a cross-sectional view of the thermometer of Fig. 1 with two absolute temperature sensors and a spring-loaded thermal contact mechanism.

FIG. 3 shows another embodiment of a thermometer with a probe enveloped by a probe cover.

FIG. 4 is a thermal diagram of the thermometer of Fig. 1 with a temperature sensing element touching the skin.

FIG. 5 is a partial cross section of an alternative temperature probe having a heater.

FIG. 6 illustrates a timing diagram of sensor response upon contact between the probe and the skin.

Fig. 7 is a block diagram of the thermometer with two temperature sensors.

FIG. 8 is a cross-sectional view of a thermometer with a handling detector in the form of a motion detector for automatic power-up.

Fig. 9 is a timing diagram of the first temperature sensor response.

Fig. 10 is a block diagram of another embodiment of a thermometer having a single temperature sensor.

### Detailed Description of The Preferred Embodiments

**[0024]** Two major issues of a patient core temperature measurement are addressed by this invention. The first is the speed of response (i.e., the speed at which an accurate temperature is displayed) and the second is a non-invasive measurement with an acceptable accuracy. The thermometer is intended for intermittent measurements of temperature by touching a selected location on the skin of a patient's body.

**[0025]** One form of the thermometer is shown in Fig. 1. The device has a housing 1 that can be held by a user's hand 24. Optional switch 5 can be used to power up the device and take a measurement. The result of measurement is represented on a display 4. Probe 3 touches skin (for example, forehead 23) of patient 22. Fig. 3 shows another embodiment of the thermometer that has an elongated neck 2 and probe 3 which are enveloped by sanitary probe cover 26 that can be of a conventional design. Usually, the probe covers 26 are narrow elongated bags fabricated of thin polymer film having thickness on the order of 0.001 inch (0.0254 mm).

**[0026]** This thermometer is intended for temperature measurements from such body sites as a carotid artery region behind the ear lobe, tragus area (near the ear), armpit, chest, abdomen, groin, and forehead. Design of a practical probe will be influenced by a selected measurement site. The basic design principles are exemplified for a forehead probe and in pertinent part will be applicable for other body site probes.

**[0027]** Fig. 2 shows a cross-sectional view of housing 1 and probe 3. Housing 1 contains a first contact type temperature sensor 6, a second thermal temperature sensor 7 and a thermal insulator 10 positioned between the two sensors 6, 7. The insulator 10 may be fabricated of any conventional insulating material or it may be just void or air space between the two sensors as shown in Fig. 2. The sensors 6, 7 are preferably absolute temperature sensors such as NTC thermistors, semiconductors, or RTDs. Here, the term "absolute" means that they can measure temperature with reference to an absolute temperature scale. Naturally, other types of sensors can be employed, such as thermocouples. However, a thermocouple being a relative sensor would require use of an absolute reference sensor. Below, thermistors are described to illustrate the operating principle. First sensor 6 is intended for coming into a thermal contact with the patient skin (in this example, via plate 20), while second sensor 7 is thermally insulated from the patient at all times. Note that sensor 7 is optional and is not essential for the operation. However, it may aid in enhancing accuracy and thus may be used if needed in a particular design.

**[0028]** For stabilizing a thermal response, sensor 7 is attached to thermal mass 9 (a metal plate). Thermal mass 9 may be supported by a circuit board 36. Likewise, sensor 6 can be attached to plate 20 that is also fabricated of metal to form a temperature sensing element. It is important to provide a good thermal coupling between first sensor 6 and plate 20. Plate 20 may be fabricated of copper having a thickness on the order of about 0.010 (0.254 mm) and gold plated to prevent oxidizing that may result from touching the patient's skin. For better coupling with the skin, plate 20 can have a convex shape. Of course, the temperature sensing element may take many alternative forms.

**[0029]** To improve the consistency of thermal contact with the patient's skin, plate 20 may be made movable. More preferably, plate 20 may be supported by shaft 8 that is mechanically connected to first spring 11 and can move in and out of probe 3. The spring 11 helps to assure a steady, constant and reliable pressure applied by plate 20 to skin 15. Shaft 8 is preferably fabricated of a material with low thermal conductivity and preferably should be made hollow (see Fig. 5). Shaft 8 may serve the function of thermal insulator 10 (Figs. 2 and 4). Both sensors, 6 and 7, are connected to the electronic components on circuit board 36 via conductors that are not shown in Fig. 2.

**[0030]** To protect a delicate probe tip (plate 20 and shaft 8) while using it or while it is in storage, another movable component or guard 17 may be employed (Fig. 2). Guard 17 is pushed downward by a second spring 12. Guard 17 can move in and out of sleeve 16. Guard 17 and sleeve 16 may be fabricated of plastic and positioned in spaced relation to plate 20 as shown in Fig. 2. The edge of guard 17 that comes in contact with the skin, can be rubberized to minimize slippage while in use. When probe 3 is not touching skin 15, guard 17 is protruding from sleeve 16, thus shielding plate 20 from possible mechanical damage. When probe 3 comes in contact with skin 15 and a sufficient pressure is applied, guard 17 slides inside sleeve 16, thus exposing plate 20 and allowing it to come in contact with skin 15. Further pressure compresses both springs 11 and 12 until guard 17 reaches its limit of movement. This provides a predetermined degree of the first spring 11 compression and aids in consistency of measurements.

**[0031]** Fig. 4 illustrates the basic principle of measuring core temperature with the device. When probe 3 is pressed against patient's skin 15, first temperature sensor 6 becomes thermally coupled to the patient core through the patient body thermal resistance  $R_s$ . The core or internal body temperature is represented as  $T_c$ . The value of  $R_s$  depends on thermal properties of skin, fat, muscles, etc. It should be kept in mind that this resistance is not constant, even for the same patient. It is affected by the ambient and patient temperatures, patient's age, clothing, etc. In fact, this resistance is under a constant physiological control by the patient's central nervous system. Temperature distribution within the probe depends on the thermometer housing temperature  $T_a$ , force of the plate 20 (Fig. 2) compression, thermal insulator 10 and any outer insulator 37 which is formed by the components inside the thermometer housing 1.

**[0032]** Reference temperature  $T_r$  is measured by second sensor 7. When the skin is touched by the probe 3, and specifically by plate 20, heat flows from the patient's core to the thermometer housing via thermal resistances  $R_s$ ,  $R_r$  and  $R_a$  (thermal resistance of outer insulator 37). Since resistance  $R_s$  is not fixed, a true core body temperature computation is impossible. However, an accurate approximation by a 2nd order equation can provide results with an acceptable degree of clinical accuracy. Equation (1) provides a practical way to compute a deep body (core) temperature from temperature of skin  $T_s$  and reference temperature  $T_r$ :

$$\text{Equation (1): } T_c = AT_s^2 + (B + CT_r)T_s + DT_r + E$$

where  $A$ ,  $B$ ,  $C$ ,  $D$  and  $E$  are the experimentally determined constants.

**[0033]** To determine the constants (A-E), temperatures from a relatively large number of patients (30 or more) are measured with the device (hereinafter "device under test" or "DUT") and a reference thermometer of a conventional design. The reference thermometer must have an acceptable degree of accuracy of measuring the body core temperatures. An example is an infrared ear (tympanic) thermometer. Since it is a well known fact that skin temperature is affected by ambient temperatures (see, for example Y. Houdas and E.F.J. Ring. Human Body Temperature. Plenum Press, New York and London. 1982), the experiments are made while the patients and the thermometers are subjected to cold, warm and normal room temperatures. Three constants (A, B and C) are inversely related to a patient's physiological limit of temperature ( $T_L$ ). The value of  $T_L$  corresponds to the highest controllable temperature of a human body that can be tolerated without irreversible damage to the internal organs. For all practical purposes it is determined as 42°C. If the measurement site is selected on a neck over a carotid artery of an adult, before collecting data, values of the constants in DUT are initially set as:

$$A=1/T_L$$

$$B=1+15/T_L$$

$$C=-0.2/T_L$$

$$D= -0.25$$

$$E= - 22$$

**[0034]** Then, data are collected from many patients and a well known in the art curve fitting technique is employed to the ensemble of temperature data. The goal of the curve fitting is to minimize differences between the DUT and the reference thermometer readings, by adjusting values of the constants. This should be done separately for different patient age groups. Other anatomical factors may also be taken into account. The constants will be different for different body sites (forehead, tragus area, etc.). After the constants are adjusted, they can be used in operating a practical thermometer.

[0035] It is important to note that in Equation (1),  $T_s$  represents a true skin temperature, yet first sensor 6 may not be able to quickly measure the true skin temperature while touching skin 15. The reason is that skin is a poor heat conductor and has a rather low thermal capacity. Thus, touching skin 15 with plate 20 for a short time alters the skin temperature from a true value of  $T_s$  to some measured value  $T_p$ . Hence, before Equation (1) can be employed, the value of a true skin temperature  $T_s$  should be computed. This can be done by using two temperatures:  $T_0$  and  $T_p$ , where  $T_0$  is the temperature of first sensor 6 before touching skin 15. This temperature is referred to as the baseline temperature. It depends on many factors, specifically, the materials used in the probe, the ambient temperature, and the history of use, i.e., how recently the probe touched the skin. For computation of  $T_s$ , Equation (2) provides a sufficient accuracy:

$$\text{Equation (2): } T_s = (\bar{T}_p - T_0)\mu + \bar{T}_p$$

where  $\mu$  is the experimentally determined constant. To find the value of  $\mu$ , multiple skin temperature measurements are made with varying  $T_0$  and then a value of  $\mu$  is selected to minimize effects of  $T_0$  on  $T_s$ . For example,  $\mu = 0.5$ .

[0036] If shaft 8 has a very low thermal conductivity and plate 20 has very low thermal capacity, the temperature measurement time may take less than about 3 seconds. However, when the probe tip is cold (baseline temperature  $T_0$  is low), plate 20 may alter the skin temperature so much that it may take a longer time to measure and compute temperature  $T_p$ . To further shorten the response time of first sensor 6, the probe tip can be pre-warmed by an embedded heater 21 as illustrated in Fig. 5. Heater 21, first sensor 6 and plate 20 are in an intimate thermal coupling with each other. Heater 21 and first sensor 6 are connected to the electronic circuit by conductors 14 and 13, respectively. Before the skin is contacted by plate 20, heater 21 elevates temperature of plate 20 to a level that is warmer than ambient and somewhat below an anticipated skin temperature. A good practical number for a pre-warming is 28 °C (82 °F). This pre-warmed temperature will be used in Equation (2) as  $T_0$ . The heater is preferably turned off before or at the instant when skin is being touched.

[0037] Before Equation (2) can be used for calculating the skin temperature  $T_s$ , an accurate determination of the first sensor 6 temperature  $T_p$  is made. This task, however, typically cannot be accomplished by just measuring and computing temperature of first sensor 6. The reason is that the temperature of sensor 6 changes rather quickly and its output signal keeps changing for an extended period of time. After the skin is touched, the heat flow from the subcutaneous tissues (carotid artery, e.g.), through the skin, to plate 20 and further through shaft 8 (which serves as a thermal insulator 10) will change with a variable rate. Fig. 6 illustrates that the temperatures of both sensors 6 and 7 change over time, while the temperature of first sensor 6 varies much more. The change in heat flow will continuously modify the temperature of the skin at the contact spot and that of first sensor 6 until a steady-state level  $T_p$  is reached. In practice, settling on a steady-state level  $T_p$  may take as long as a minute - a very long time indeed. To shorten the computation time dramatically, for example, to arrive at  $T_p$  within a second rather than a minute the following technique is employed.

[0038] First, a rate of heat flow through shaft 8 is determined. The rate is measured by taking multiple readings from sensor 6 as shown in Fig. 6. After the temperature detected by sensor 6 starts moving from the base level  $T_0$  (upon touching the skin), pairs of data points are selected from a series of readings: Multiple pairs of data points (temperatures at points  $x$  and  $y$ ) from the sensor 6 should be taken over time delays  $t_0$ . It is important that the time delay  $t_0$  between points  $x$  and  $y$  is constant and known. Next, Equation (3) is employed to determine the rate of heat flow:

$$\text{Equation (3): } T_{pd} = \frac{T_{6y} - kT_{6x}}{1 - k},$$

where  $k$  is a constant. Typically it is equal to 0.5 for  $t_0 = 500$  ms,  $T_{6x}$  and  $T_{6y}$  are the temperatures measured at points  $x$  and  $y$  respectively.

[0039] Second, multiple values of  $T_{pj}$  are computed from a series of pairs  $x$  and  $y$  and compared with one another. When the difference between two adjacent  $T_{pj}$  becomes small, these two values of  $T_{pj}$  are averaged and the result  $T_p$  is used in Equation (2). If second sensor 7 is employed and its temperature changes as well (as in Fig. 6), a similar technique can be employed to compute  $T_r$  from second sensor 7.

[0040] Fig. 7 shows a block diagram of a thermometer in accordance with an embodiment of this invention. Two thermistors are used as respective first and second sensors 6, 7. They are pulled up by first and second pull-up resistors 18 and 19, respectively, that are connected to a constant reference voltage 25 generated by power supply circuit 35. Signals from both sensors 6, 7 are fed into a multiplexer 32 which is a gate to allow passage of only one signal at a time. The output signal of multiplexer 32 is applied to an analog-to-digital (A/D) converter 33. All these parts are under control of microcontroller 34, electric power to which can be turned on by switch 5. The result of the core temperature computation

is presented on display 4. It should be understood that a similar but modified circuit may be used with a probe having different types of sensors, such as semiconductors, e.g., and signals from various sensors may be used by microcontroller 34 to compute the body core temperature by employing methods as described above.

**[0041]** There are several ways to detect when plate 20 touches the skin. One way is to use switch 40. To detect the instant when the skin is being touched by plate 20, switch 40 may be mechanically coupled to plate 20 and shaft 8 (Figs. 2 and 7). When shaft 8 moves, switch 40 closes and sends a signal to microcontroller 34, thus indicating that the skin was touched. If the use of a switch 40 is not desired, other ways to detect touching the skin may be used. For example, after power up, microcontroller 34 can constantly check temperatures of sensor 6 at predetermined time intervals  $t_d$  (Fig. 9). A temperature of first sensor 6 stays on a relatively stable level until the probe touches the patient's skin. At this moment, temperature of first sensor 6 begins to rise sharply. A difference between temperatures  $T_1$  and  $T_2$  is detected to be larger than earlier and this event signals the microcontroller that the skin was touched and the measurements and computation must start.

**[0042]** To make the thermometer more user-friendly, some of its functions can be automated. For example, power switch 5 can be eliminated entirely. Power to the circuit may be turned on automatically by a handling detector when the device is picked-up by a user. Fig. 8 illustrates a simple motion detector 28 that is gravity operated. It has several electrodes 29 embedded into a hollow capsule 30. Electrically conductive ball 27 resides inside capsule 30. When the position of the device changes after being picked up, ball 30 rolls inside capsule 30 making intermittent contact with the internal electrodes 29. This modulates electrical resistances between the adjacent contacts and can be detected by microcontroller 34, signaling it to turn power on. Alternatively, or in addition, housing 1 of the thermometer may have metal contacts on its outer surface that would be part of a capacitive touch sensor. Such a touch sensor may turn on the power similarly to the motion sensor 28 described above. These are just well known examples of various sensors that may be referred to as "handling detectors." Many such detectors or sensors are known in art and thus not described in further detail herein. Some of these detectors are described in a book by Jacob Fraden "Handbook of Modern Sensors" (3rd ed., Springer Verlag, NY, 2004) herein incorporated by reference. Note that switch 40 also may be employed as a handling detector for turning power on. When power is off, the probe 3 may be tapped on a surface, such as a table surface. This would momentarily close switch 40, signaling the microcontroller that the measurement cycle may start.

**[0043]** As merely one illustration, the thermometer of Fig. 7 operates as follows. Initially, the thermometer typically is in storage, such as in a medicine cabinet and its power is off. After being picked-up, motion detector 28 (not shown in Fig. 7) turns power on and temperatures from both sensors 6 and 7 alter the thermistor resistances. Signals from the sensors 6, 7 are fed into multiplexer 32 and then pass to A/D converter 33. Temperatures of sensors 6 and 7 are measured and computed continuously with a predetermined rate. The temperature of first sensor 6 ( $T_0$ ), before the skin is touched, is stored in memory and will be used later for computing the skin temperature  $T_s$  by use of Equation (2). The temperature of second sensor 7 is measured and stored as  $T_r$ . To take a reading, the user pushes the probe tip against the patient's skin and switch 40 closes, indicating the moment of skin touching. The temperature of first sensor 6 rises and is read continuously in a digital format by A/D converter 33. From each pair of the first sensor readings separated by  $t_o$ , a heat flow rate of change is measured and computed from Equation (3). When microcontroller 34 determines that the rate of change has reached a sufficiently steady value, it computes  $T_p$  as described above and subsequently employs Equation (2) to compute the skin temperature  $T_s$ . Then, using Equation (1), the patient's core temperature  $T_c$  is finally computed by using constants, obtained as described above, and stored in the internal memory. The entire process may take only a few seconds from the moment of skin touching.

**[0044]** Some additional computations may also be performed to aid in usefulness of the device. These may include changing the display scale, testing the temperature limits, checking the power supply, etc. Power of the thermometer may be turned off automatically by microcontroller 34 after a preset delay of, for example, 60 seconds.

**[0045]** In another embodiment of the invention, only one temperature sensor is used (first sensor 6). This is illustrated in Fig. 10. Since the second temperature sensor 7 is absent, its function is taken over by first temperature sensor 6. Operation of the circuit of Fig. 10 is nearly identical to that of Fig. 7. except that reference temperature  $T_r$  is measured by first sensor 6 after power up, as a first control operation, and stored in the internal memory (not shown) of microcontroller 34 for later use in Equation (1).

**[0046]** While the present invention has been illustrated by a description of various preferred embodiments and while these embodiments have been described in some detail, additional advantages and modifications will readily appear to those skilled in the art.

## Claims

1. A temperature sensing device (3) operative to determine the core temperature of a warm blooded animal or human based on at least one measurement of the temperature of the skin of the warm blooded animal or human, the device comprising a housing (1), a first contact type temperature sensing element (6, 20) coupled to the housing (1) and

including a first temperature sensor (6), the first temperature sensor (6) operative to measure the temperature of the skin when the first contact type temperature sensing element (6, 20) is in contact with the skin to produce at least a first signal, a moveable element (8) carrying the first contact type temperature sensing element (6, 20), the moveable element (8) configured to be moved into a first position at which the first contact type temperature sensing element (6, 20) is adapted for contact with the skin, an electronic circuit (36) electrically coupled with the first contact type temperature sensing element (6, 20) and operative to use the first signal to determine the core temperature of the warm blooded animal or human, and an electronic communication device (4) coupled to the electronic circuit (36) and operative to communicate the core temperature to a user, wherein the moveable element (8) is configured to be moved into a second position at which the first contact type temperature sensing element (6, 20) is not adapted for contact with the skin, **characterized in that** the device further comprises a guard (17) coupled to the housing (1) and configured to surround and protect the first contact type temperature sensing element (6, 20) when not in use, the guard (17) further being moveable relative to the first contact type temperature sensing element (6, 20) to allow the first contact type temperature sensing element (6, 20) to contact the skin while measuring the temperature of the skin.

2. The device of claim 1, further comprising a thermal insulator (10) positioned adjacent the first temperature sensor (6).
3. The device of claim 2, further comprising a second temperature sensor (7) coupled to the housing (1), the thermal insulator (10) positioned generally between the first and second temperature sensors (6, 7) so as to thermally decouple the first and second temperature sensors (6, 7) from each other, and the second temperature sensor (7) further being positioned so as to be thermally decoupled from the skin during measurement of the skin with the first temperature sensor (6), the second temperature sensor (7) operative to detect a reference temperature represented by at least a second signal, and wherein the electronic circuit (36) uses the first and second signals to accurately determine the core temperature.
4. The device of any preceding claim, wherein the moveable element (8) further comprises a shaft formed from a thermally insulating material.
5. The device of claim 4, wherein the shaft is spring loaded to normally bias the first contact type temperature sensing element toward the first position.
6. The device of any preceding claim, further comprising a heating element (21) thermally coupled to said first temperature sensor (6), wherein the heating element (21) generates heat prior to the first temperature sensor being placed in contact with skin of the patient.
7. The device of any preceding claim, further comprising a power supply (35) coupled to the first temperature sensor (6), the electronic circuit (36) electrically coupled to the first temperature sensor (6) and the power supply (35), and a handling detector (28) coupled with the power supply (35) and operative to detect handling of the device by the user, and, in response, activate the supply of power from the power supply (35) to the electronic circuit (36).
8. The device of claim 7, wherein the handling detector further comprises at least one of a motion sensor (28) and a capacitive touch sensor.
9. The device of claim 7, wherein the handling detector (28) further comprises a switch (40) mechanically coupled to the first temperature sensor (6).

## Patentansprüche

1. Temperaturfühlvorrichtung (3) zum Ermitteln der Kerntemperatur eines warmblütigen Tiers oder Menschen auf der Basis von wenigstens einem Messwert der Temperatur der Haut des warmblütigen Tiers oder Menschen, wobei die Vorrichtung Folgendes umfasst: ein Gehäuse (1), ein erstes Temperaturfühlelement (6, 20) des Kontakttyps, das mit dem Gehäuse (1) gekoppelt und mit einem ersten Temperatursensor (6) ausgestattet ist, wobei der erste Temperatursensor (6) die Aufgabe hat, die Temperatur der Haut zu messen, wenn das Temperaturfühlelement (6, 20) des Kontakttyps mit der Haut in Kontakt ist, zum Erzeugen wenigstens eines ersten Signals, wobei ein bewegliches Element (8) das Temperaturfühlelement (6, 20) des Kontakttyps trägt, wobei das bewegliche Element (8) zum Bewegen in eine erste Position konfiguriert ist, in der das erste Temperaturfühlelement (6, 20) des Kontakttyps für den Kontakt mit der Haut adaptiert ist, eine elektronische Schaltung (36), die elektrisch mit dem ersten Tempe-

raturfühlelement (6, 20) des Kontakttyps gekoppelt ist und die Aufgabe hat, das erste Signal zum Ermitteln der Kerntemperatur des warmblütigen Tiers oder Menschen zu benutzen, und ein elektronisches Kommunikationsgerät (4), das mit der elektronischen Schaltung (36) gekoppelt ist und die Aufgabe hat, die Kerntemperatur einem Benutzer zu übermitteln, wobei das bewegliche Element (8) zum Bewegen in eine zweite Position konfiguriert ist, in der das erste Temperaturfühlelement (6, 20) des Kontakttyps nicht für den Kontakt mit der Haut adaptiert ist, **dadurch gekennzeichnet, dass** die Vorrichtung ferner einen Schutz (17) umfasst, der mit dem Gehäuse (1) gekoppelt und so konfiguriert ist, dass er das erste Temperaturfühlelement (6, 20) des Kontakttyps umgibt und schützt, wenn es nicht im Gebrauch ist, wobei der Schutz (17) ferner relativ zu dem ersten Temperaturfühlelement (6, 20) des Kontakttyps beweglich ist, damit das erste Temperaturfühlelement (6, 20) des Kontakttyps die Haut kontaktieren kann, während die Temperatur der Haut gemessen wird.

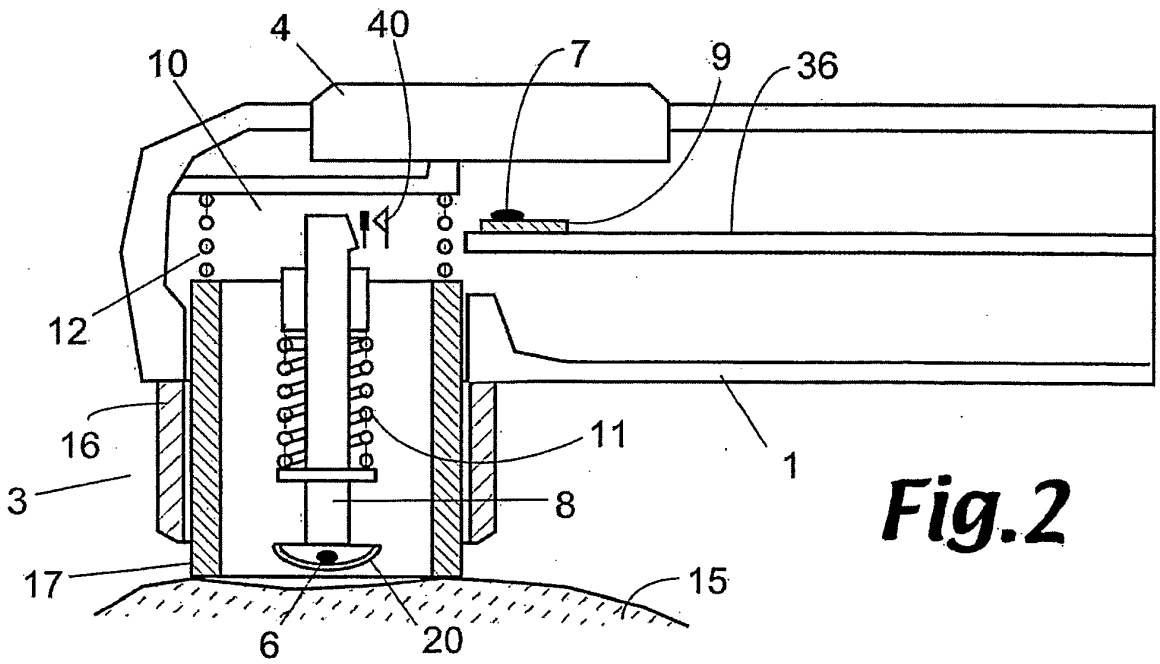
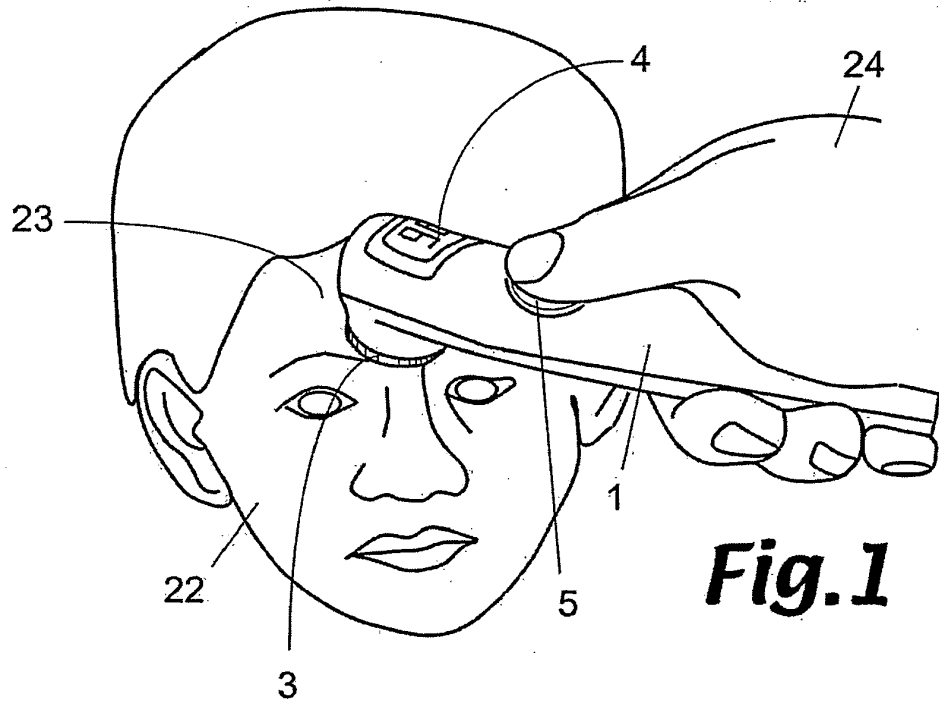
2. Vorrichtung nach Anspruch 1, die ferner einen Wärmeisolator (10) umfasst, der neben dem ersten Temperatursensor (6) positioniert ist.
3. Vorrichtung nach Anspruch 2, die ferner einen mit dem Gehäuse (1) gekoppelten zweiten Temperatursensor (7) umfasst, wobei der Wärmeisolator (10) allgemein zwischen dem ersten und dem zweiten Temperatursensor (6, 7) positioniert ist, um den ersten und zweiten Temperatursensor (6, 7) thermisch voneinander abzukoppeln, und wobei der zweite Temperatursensor (7) ferner so positioniert ist, dass er während der Messung der Haut mit dem ersten Temperatursensor (6) thermisch von der Haut abgekoppelt ist, wobei der zweite Temperatursensor (7) die Aufgabe hat, eine von wenigstens einem zweiten Signal repräsentierte Referenztemperatur zu erkennen, und wobei die elektronische Schaltung (36) das erste und zweite Signal benutzt, um die Kerntemperatur genau zu ermitteln.
4. Vorrichtung nach einem vorherigen Anspruch, wobei das bewegliche Element (8) ferner einen Schaft umfasst, der aus einem wärmeisolierenden Material gebildet ist.
5. Vorrichtung nach Anspruch 4, wobei der Schaft federbelastet ist, um das erste Temperaturfühlelement des Kontakttyps normalerweise in die erste Position vorzuspannen.
6. Vorrichtung nach einem vorherigen Anspruch, die ferner ein Heizelement (21) umfasst, das thermisch mit dem ersten Temperatursensor (6) gekoppelt ist, wobei das Heizelement (21) Wärme erzeugt, bevor der erste Temperatursensor in Kontakt mit der Haut des Patienten platziert wird.
7. Vorrichtung nach einem vorherigen Anspruch, die ferner Folgendes umfasst: eine mit dem ersten Temperatursensor (6) gekoppelte Stromversorgung (35), wobei die elektronische Schaltung (36) elektrisch mit dem ersten Temperatursensor (6) und der Stromversorgung (35) gekoppelt ist, und einen Handhabungsdetektor (28), der mit der Stromversorgung (35) gekoppelt ist und die Aufgabe hat, die Handhabung der Vorrichtung durch den Benutzer zu erkennen und als Reaktion darauf die Zufuhr von Strom von der Stromversorgung (35) zu der elektronischen Schaltung (36) zu aktivieren.
8. Vorrichtung nach Anspruch 7, wobei der Handhabungsdetektor ferner einen Bewegungssensor (28) und/oder einen kapazitiven Berührungssensor umfasst.
9. Vorrichtung nach Anspruch 7, wobei der Handhabungsdetektor (28) ferner einen Schalter (40) umfasst, der mechanisch mit dem ersten Temperatursensor (6) gekoppelt ist.

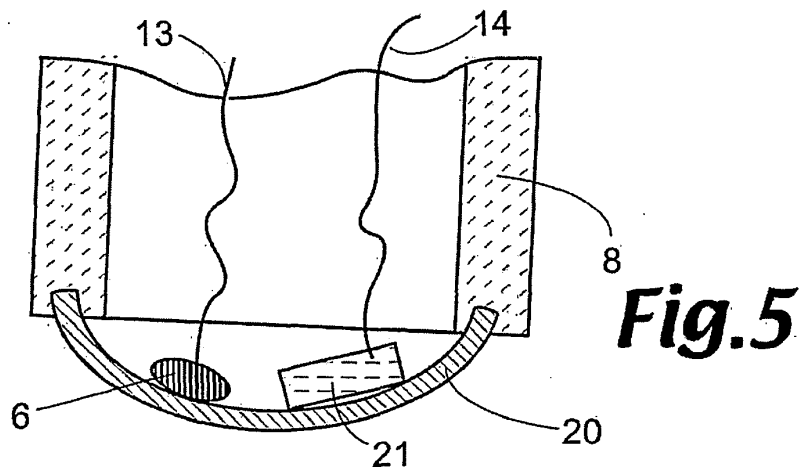
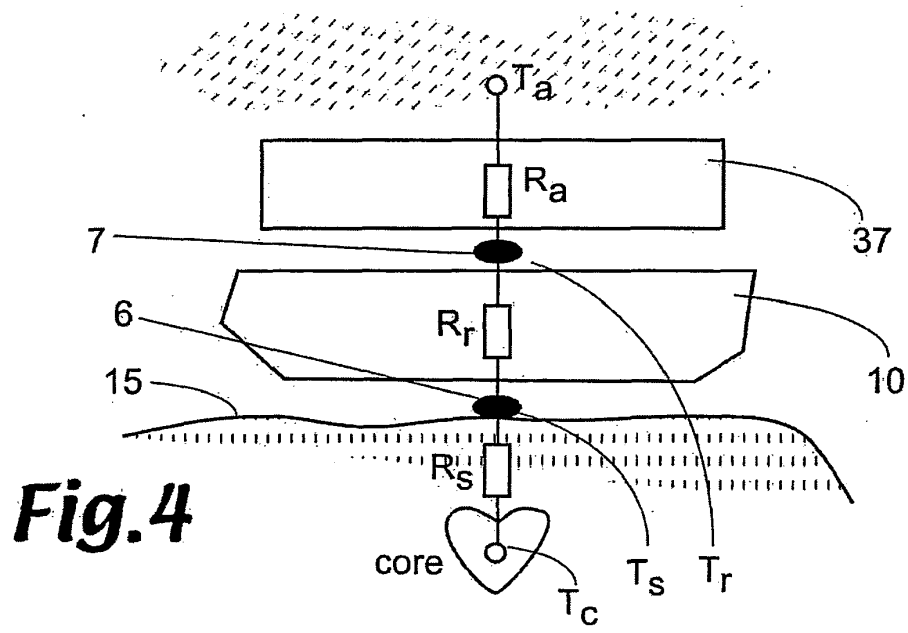
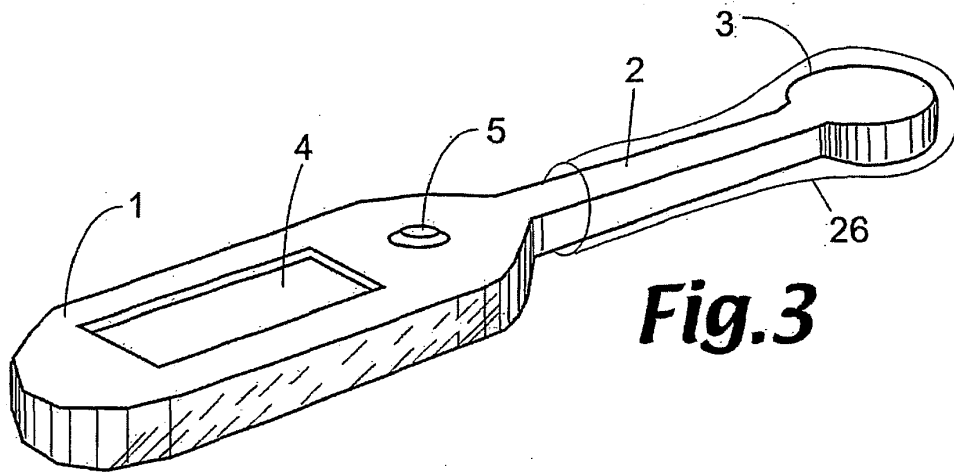
### Revendications

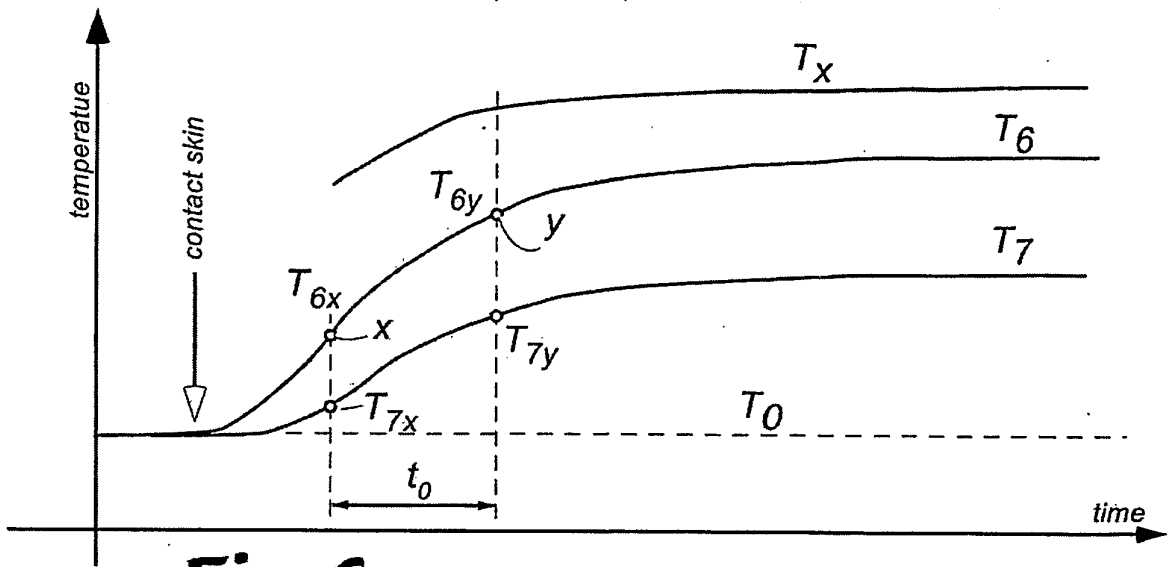
1. Dispositif de détection de température (3) servant à déterminer la température interne d'un animal ou d'un humain à sang chaud en fonction au moins d'une mesure de la température de la peau de l'animal ou de l'humain à sang chaud, le dispositif comprenant un logement (1), un premier élément de détection de température du type à contact (6, 20) couplé au logement (1) et comportant un premier capteur de température (6), le premier capteur de température (6) servant à mesurer la température de la peau quand le premier élément de détection de température du type à contact (6, 20) est en contact avec la peau pour produire au moins un premier signal, un élément mobile (8) portant le premier élément de détection de température du type à contact (6, 20), l'élément mobile (8) étant configuré pour être déplacé sur une première position à laquelle le premier élément de détection de température à contact (6, 20) est adapté pour faire contact avec la peau, un circuit électronique (36) couplé électriquement au premier élément de détection de température du type à contact (6, 20) et servant à utiliser le premier signal pour déterminer

la température interne de l'animal ou de l'humain à sang chaud, et un dispositif de communication électronique (4) couplé au circuit électronique (36) et servant à communiquer la température interne à un utilisateur, dans lequel l'élément mobile (8) est configuré pour être déplacé sur une seconde position à laquelle le premier élément de détection de température du type à contact (6, 20) n'est pas adapté pour faire contact avec la peau, **caractérisé en ce que** le dispositif comprend en outre une garde (17) couplée au logement (1) et configurée pour entourer et protéger le premier élément de détection de température du type à contact (6, 20) quand il n'est pas en service, la garde (17) étant en outre déplaçable relativement au premier élément de détection de température du type à contact (6, 20) pour permettre au premier élément de détection de température du type contact (6, 20) de faire contact avec la peau pendant la mesure de la température de la peau.

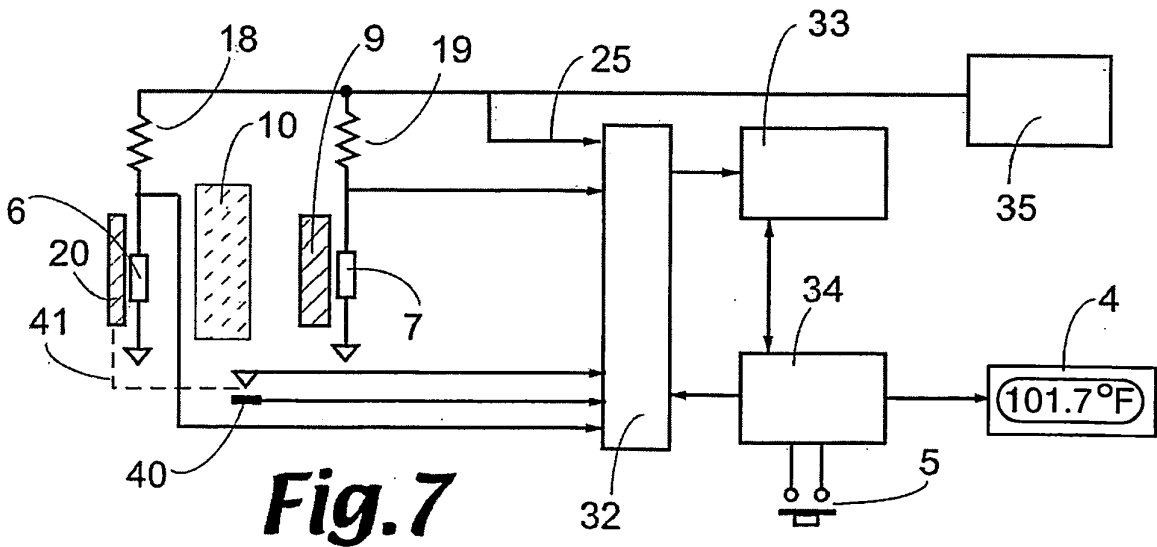
2. Dispositif selon la revendication 1, comprenant en outre un isolant thermique (10) positionné adjacent au premier capteur de température (6).
3. Dispositif selon la revendication 2, comprenant en outre un second capteur de température (7) couplé au logement (1), l'isolant thermique (10) étant positionné généralement entre les premier et second capteurs de température (6, 7) de manière à découpler thermiquement les premier et second capteurs de température (6, 7) l'un de l'autre, et le second capteur de température (7) étant positionné en outre de manière à être découplé thermiquement de la peau durant la mesure de la peau avec le premier capteur de température (6), le second capteur de température (7) servant à détecter une température de référence représentée par au moins un second signal, et dans lequel le circuit électronique (36) utilise les premier et second signaux pour déterminer précisément la température interne.
4. Dispositif selon l'une quelconque des revendications précédentes, dans lequel l'élément mobile (8) comprend en outre une tige formée en un matériau thermiquement isolant.
5. Dispositif selon la revendication 4, dans lequel la tige est à ressort pour solliciter normalement le premier élément de détection de température du type contact vers la première position.
6. Dispositif selon l'une quelconque des revendications précédentes, comprenant en outre un élément chauffant (21) couplé thermiquement audit premier capteur de température (6), dans lequel l'élément chauffant (21) génère une chaleur avant le placement du premier capteur de température en contact avec la peau du patient.
7. Dispositif selon l'une quelconque des revendications précédentes, comprenant en outre une alimentation électrique (35) couplée au premier capteur de température (6), le circuit électronique (36) étant couplé électriquement au premier capteur de température (6) et à l'alimentation électrique (35), et un détecteur de manipulation (28) couplé à l'alimentation électrique (35) et servant à détecter une manipulation du dispositif par l'utilisateur, et, en réponse, activer l'alimentation de puissance depuis l'alimentation électrique (35) vers le circuit électronique (36).
8. Dispositif selon la revendication 7, dans lequel le détecteur de manipulation comprend en outre au moins l'un d'un capteur de mouvement (28) et d'un capteur de toucher capacitif.
9. Dispositif selon la revendication 7, dans lequel le détecteur de manipulation (28) comprend en outre un commutateur (40) couplé mécaniquement au premier capteur de température (8).



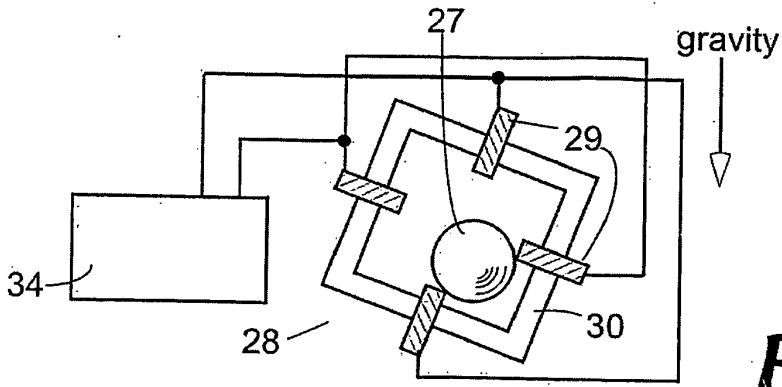




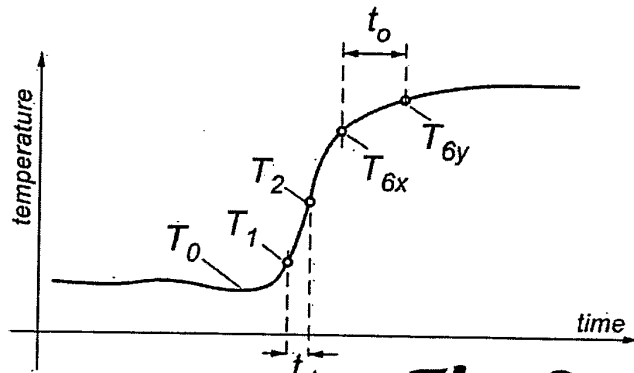
**Fig.6**



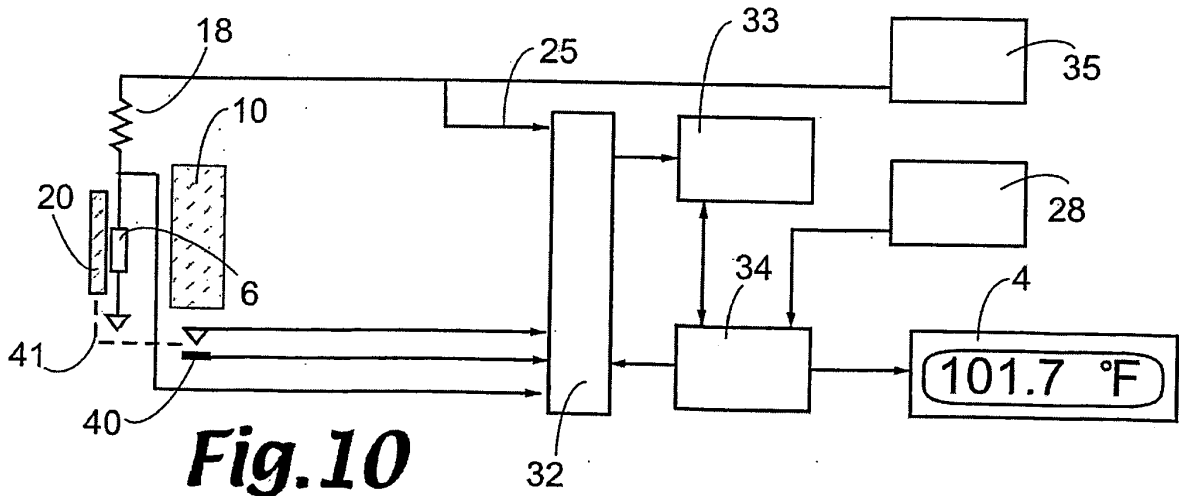
**Fig.7**



**Fig.8**



**Fig.9**



**Fig.10**

**REFERENCES CITED IN THE DESCRIPTION**

*This list of references cited by the applicant is for the reader's convenience only. It does not form part of the European patent document. Even though great care has been taken in compiling the references, errors or omissions cannot be excluded and the EPO disclaims all liability in this regard.*

**Patent documents cited in the description**

- US 4790324 A, O'Hara [0003]
- US 4854730 A [0003]
- US 200210114375 A [0004]
- US 3978325 A [0005]
- US 3872726 A, Kauffeld [0005]
- WO 9619938 A [0012]
- US 3832902 A [0013]

**Non-patent literature cited in the description**

- **Y. HOUDAS ; E.F.J. RING.** Human Body Temperature. Plenum Press, 1982 [0033]
- **JACOB FRADEN.** Handbook of Modern Sensors. Springer Verlag, 2004 [0042]

专利名称(译)	医用人体核心温度计		
公开(公告)号	<a href="#">EP1768546B1</a>	公开(公告)日	2016-04-13
申请号	EP2005713646	申请日	2005-02-16
[标]申请(专利权)人(译)	阿德望斯监控器公司		
申请(专利权)人(译)	高级MONITORS CORPORATION		
当前申请(专利权)人(译)	KAZ , INC.		
[标]发明人	FRADEN JACOB		
发明人	FRADEN, JACOB		
IPC分类号	A61B5/00 G01K7/42 G01K13/00		
CPC分类号	A61B5/01 G01K1/165 G01K1/20 G01K7/42 G01K7/427 G01K13/002 G01K2215/00		
优先权	10/870654 2004-06-18 US		
其他公开文献	EP1768546A1 EP1768546A4 EP1768546B8		
外部链接	<a href="#">Espacenet</a>		

摘要(译)

温度感测装置基于对所述暖血动物或人的皮肤的温度的至少一种测量来准确地确定所述温血动物或人的核心温度。该装置包括壳体和耦合到壳体的第一接触型温度感测元件。第一接触型温度感测元件包括第一温度传感器，当第一接触型温度感测元件与皮肤接触时，该第一温度传感器用于测量皮肤的温度。第一温度传感器至少产生代表所测量的皮肤温度的第一信号。电子电路使用第一信号确定温血动物或人类的核心温度。电子通信设备，例如显示器，耦合到电子电路，用于将核心温度传递给用户。

