

(19)



(11)

**EP 3 476 380 B1**

(12)

**EUROPEAN PATENT SPECIFICATION**

(45) Date of publication and mention of the grant of the patent:  
**13.05.2020 Bulletin 2020/20**

(51) Int Cl.:  
**A61G 7/00** <sup>(2006.01)</sup>      **A61G 7/057** <sup>(2006.01)</sup>  
**A61G 7/008** <sup>(2006.01)</sup>      **A61G 7/015** <sup>(2006.01)</sup>  
**A61B 5/00** <sup>(2006.01)</sup>

(21) Application number: **18200545.4**

(22) Date of filing: **15.10.2018**

**(54) MODULAR TURN ASSIST APPARATUS AND METHOD THEREFOR**

MODULARE DREHASSISTENZVORRICHTUNG UND VERFAHREN DAFÜR  
APPAREIL D'ASSISTANCE MODULAIRE EN VIRAGE ET PROCÉDÉ ASSOCIÉ

(84) Designated Contracting States:  
**AL AT BE BG CH CY CZ DE DK EE ES FI FR GB GR HR HU IE IS IT LI LT LU LV MC MK MT NL NO PL PT RO RS SE SI SK SM TR**

- **EMMONS, Kirsten M.**  
Batesville, Indiana 47006-9167 (US)
- **MEYERSON, Craig M.**  
Batesville, Indiana 47006-9167 (US)
- **HEIL, Thomas F**  
Batesville, Indiana 47006-9167 (US)

(30) Priority: **24.10.2017 US 201762576275 P**

(43) Date of publication of application:  
**01.05.2019 Bulletin 2019/18**

(74) Representative: **Findlay, Alice Rosemary Reddie & Grose LLP**  
**The White Chapel Building**  
**10 Whitechapel High Street**  
**London E1 8QS (GB)**

(73) Proprietor: **Hill-Rom Services, Inc.**  
**Batesville, IN 47006-9167 (US)**

(72) Inventors:  
• **RIBBLE, David Lance**  
**Batesville, Indiana 47006-9167 (US)**

(56) References cited:  
**EP-A1- 3 015 058**      **US-A1- 2009 106 906**  
**US-A1- 2014 047 644**      **US-A1- 2014 345 060**

**EP 3 476 380 B1**

Note: Within nine months of the publication of the mention of the grant of the European patent in the European Patent Bulletin, any person may give notice to the European Patent Office of opposition to that patent, in accordance with the Implementing Regulations. Notice of opposition shall not be deemed to have been filed until the opposition fee has been paid. (Art. 99(1) European Patent Convention).

## Description

**[0001]** The present disclosure relates to a therapeutic support apparatus. More specifically, the present disclosure relates to a therapeutic support apparatus with sleep state monitoring.

**[0002]** The subject matter disclosed herein relates generally to adverse event mitigation devices, systems, and methods and, more particularly, but not exclusively, to devices, systems, and methods for the prevention and treatment of sleep apnea. These devices, systems, and methods may include an active intervention, a passive intervention, or a continuous intervention. The embodiments described herein may also be effective in reducing snoring. An exemplary sleep apparatus is described in US 2014/0345060 A1, in the name of Hill-Rom Services, Inc.. The sleep apparatus comprises a head support surface sized to support a person's head, and a torso support surface sized to support a person's torso. The head support surface is generally laterally sloped moving from the first side toward the second side, and the torso support surface is generally laterally sloped moving from the first side toward the second side.

**[0003]** While various adverse event mitigation devices, systems, and methods have been developed, there is still room for improvement. Thus, a need persists for further contributions in this area of technology.

**[0004]** The present disclosure includes one or more of the following features alone or in any combination. The present invention is defined in the appended claims.

**[0005]** According to one aspect of the disclosure, a therapeutic support apparatus includes a user support surface extending along a longitudinal axis. The user support surface may have a head section and a torso section. Each of the head section and the torso section may be operable to angle relative to the longitudinal axis. An elevation unit may be operable to position at least one of the head section and torso section at angles relative to the longitudinal axis. A monitor may acquire data related to a user while sleeping on the user support surface. An alarm may be operable to activate based on the data acquired by the monitor. At least one of the elevation unit and the alarm may be activated in response to the data acquired by the monitor to control oxygen desaturation of the user.

**[0006]** In some embodiments, the elevation unit may include a first plate couple to a second plate at a hinge. At least one inflatable bladder may be positioned between the first plate and the second plate. The at least one inflatable bladder may be operable to inflate and deflate to move the second plate to an angle relative to the first plate. The at least one inflatable bladder may include a head bladder and a torso bladder. The head bladder may be operable to inflate and deflate to move a head section of the second plate to a head angle relative to the first plate. The torso bladder may be operable to inflate and deflate to move a torso section of the second plate to a torso angle relative to the first plate. The head

bladder may be operable to inflate and deflate to a first capacity. The torso bladder may be operable to inflate and deflate to a second capacity. The first capacity may be different than the second capacity. The head bladder and the torso bladder may cooperate to form a compound angle. The head angle and the torso angle may be different. The head angle may be greater than the torso angle. The head section of the second plate and the torso section of the second plate may cooperate to form a compound angle.

**[0007]** Alternatively or in addition to, the elevation unit may change a head angle of the head section of the second plate in response to the data acquired by the monitor. The elevation unit may change the torso angle of the torso section of the second plate in response to the data acquired by the monitor. The elevation unit may move the head section of the second plate in response to the data acquired by the monitor to alter a sleep stage of the user. The elevation unit may move the torso section of the second plate in response to the data acquired by the monitor to alter a sleep stage of the user. At least one tether may couple the first plate and the second plate. The elevation unit may include an expandable envelope. The first plate, the second plate, and the at least one inflatable bladder may be housed within the expandable envelope.

**[0008]** Optionally, the elevation unit may include a first plate couple to a second plate at a first hinge. A third plate may be coupled to the second plate at a second hinge. The first plate, the second plate, and the third plate may be formed from a flexible material. At least one inflatable right bladder may be positioned between the first plate and the second plate. At least one inflatable left bladder may be positioned between the second plate and the third plate. The at least one inflatable right bladder may be operable to inflate and deflate to move the second plate to an angle relative to the first plate. The at least one inflatable left bladder may be operable to inflate and deflate to move the third plate to an angle relative to the second plate. The at least one inflatable right bladder may have a right head bladder and a right torso bladder. The right head bladder may be operable to inflate and deflate to move a head section of the second plate to a head angle relative to the first plate. The right torso bladder may be operable to inflate and deflate to move a torso section of the second plate to a torso angle relative to the first plate. The right head bladder may be operable to inflate and deflate to a first capacity. The right torso bladder may be operable to inflate and deflate to a second capacity, wherein the first capacity is different than the second capacity. The right head bladder and the right torso bladder may cooperate to form a compound angle. The at least one inflatable left bladder may have a left head bladder and a left torso bladder. The left head bladder may be operable to inflate and deflate to move a head section of the second plate to a head angle relative to the first plate. The left torso bladder may be operable to inflate and deflate to move a torso section of the second

plate to a torso angle relative to the first plate. The left head bladder may be operable to inflate and deflate to a first capacity. The left torso bladder may be operable to inflate and deflate to a second capacity. The first capacity may be different than the second capacity. The left head bladder and the left torso bladder may cooperate to form a compound angle.

**[0009]** It may be desired that the user support surface is positioned on a frame. The elevation unit may be positioned between the frame and the user support surface. The elevation unit may include at least one strap to secure the elevation unit to the frame. The alarm may be an audible alarm. The alarm may be a visual alarm. The data acquired may include at least one of head angle and torso angle. The data acquired may include at least one of respiratory rate, respiratory amplitude, oxygen saturation, apnea hypopnea index, sleep state, and snoring.

**[0010]** A method of controlling oxygen desaturation of a user on a therapeutic support apparatus having a head section and a torso section is disclosed. The head section and the torso may each be operable to angle relative to a longitudinal axis. The method may include positioning the head section of the therapeutic support apparatus at a head angle with an elevation unit. The torso section of the therapeutic support apparatus may be positioned at a torso angle with the elevation unit. Data related to a user while sleeping on the therapeutic support apparatus may be acquired. The method may include activating at least one of the elevation unit or an alarm in response to the data acquired.

**[0011]** In some embodiments, positioning the head section of the therapeutic support apparatus at a head angle may include inflating a head bladder of the elevation unit. Positioning a torso section of the therapeutic support apparatus at a torso angle may include inflating a torso bladder of the elevation unit. Positioning the head section of the therapeutic support apparatus at a head angle may include inflating the head bladder of the elevation unit to a first capacity. Positioning a torso section of the therapeutic support apparatus at a torso angle may include inflating the torso bladder of the elevation unit to a second capacity. The first capacity may be different than the second capacity. The head bladder and the torso bladder may cooperate to form a compound angle. The head section of the therapeutic support apparatus may be positioned at a head angle that is different than the torso angle of the torso section of the therapeutic support apparatus. The head section of the therapeutic support apparatus may be positioned at a head angle that is greater than the torso angle of the torso section of the therapeutic support apparatus. The torso section of the therapeutic support apparatus may be positioned at a torso angle that cooperates with the head angle of the head section of the therapeutic support apparatus to form a compound angle.

**[0012]** Alternatively or in addition to, the head angle of the head section of the therapeutic support apparatus may be altered with the elevation unit in response to the

data acquired by the monitor. The torso angle of the torso section of the therapeutic support apparatus may be altered with the elevation unit in response to the data acquired by the monitor. The head section of the therapeutic support apparatus may be moved with the elevation unit in response to the data acquired by the monitor to alter a sleep stage of the user. The torso section of the therapeutic support apparatus with the elevation unit may be moved in response to the data acquired by the monitor to alter a sleep stage of the user.

**[0013]** Optionally, the elevation unit may be positioned between a frame and the user support surface. The elevation unit may be secured to the frame with at least one strap. The method may include activating an audible alarm. The method may include activating a visual alarm. Data may be acquired related to at least one of head angle and torso angle. Data may be acquired related to at least one of respiratory rate, respiratory amplitude, oxygen saturation, apnea hypopnea index, sleep state, and snoring.

**[0014]** According to another aspect, a therapeutic elevation unit may include a first plate coupled to a second plate at a first hinge. A third plate may be coupled to the second plate at a second hinge. At least one inflatable right bladder may be positioned between the first plate and the second plate. At least one inflatable left bladder may be positioned between the second plate and the third plate. The at least one inflatable right bladder may be operable to inflate and deflate to move the second plate to an angle relative to the first plate. The at least one inflatable left bladder may be operable to inflate and deflate to move the third plate to an angle relative to the second plate. Optionally, the first plate, the second plate, and the third plate may be formed from a flexible material.

**[0015]** In some embodiments, the at least one inflatable right bladder may include a right head bladder and a right torso bladder. The right head bladder may be operable to inflate and deflate to move a head section of the second plate to a head angle relative to the first plate. The right torso bladder may be operable to inflate and deflate to move a torso section of the second plate to a torso angle relative to the first plate. The right head bladder may be operable to inflate and deflate to a first capacity. The right torso bladder may be operable to inflate and deflate to a second capacity. The first capacity may be different than the second capacity. The right head bladder and the right torso bladder may cooperate to form a compound angle.

**[0016]** Alternatively, or in addition to, the at least one inflatable left bladder may include a left head bladder and a left torso bladder. The left head bladder may be operable to inflate and deflate to move a head section of the second plate to a head angle relative to the first plate. The left torso bladder may be operable to inflate and deflate to move a torso section of the second plate to a torso angle relative to the first plate. The left head bladder may be operable to inflate and deflate to a first capacity. The left torso bladder may be operable to inflate and deflate

to a second capacity. The first capacity may be different than the second capacity. The left head bladder and the left torso bladder may cooperate to form a compound angle.

**[0017]** The invention will now be further described by way of example with reference to the accompanying drawings, in which:

FIG. 1 is a perspective view of a bed frame and mattress (in phantom) according to an illustrative embodiment of the present disclosure, showing an elevation unit embodied as a set of bladders (in phantom) situated between the mattress and the bed frame;

FIG. 2 is a perspective view of the elevation unit of FIG. 1 raising a right side of the mattress to form a compound head/torso angle;

FIG. 3 is a perspective view of the elevation unit similar to FIG. 2 raising a left side of the mattress to form a compound head/torso angle;

FIG. 4 is a perspective view of the elevation unit shown in FIG. 1 coupled to a source of air;

FIG. 5 is an elevation head side view of the elevation unit shown in FIG. 4 having the right side bladders inflated;

FIG. 6 is an elevation right side view of the elevation unit shown in FIG. 4 having the right head bladder inflated to a greater capacity than the right torso bladder;

FIG. 7 is a perspective view of the elevation unit shown in FIG. 4 having the right head bladder inflated to a greater capacity than the right torso bladder; and FIG. 8 is an elevation head side view of the elevation unit shown in FIG. 4 having the left side bladders inflated;

FIG. 9 is a flowchart illustrating a method for operating the elevation unit shown in FIG. 1.

**[0018]** The embodiments described herein relate to devices, systems and methods to reduce the occurrence and/or duration of or prevent sleep apnea events and/or snoring. The embodiments demonstrate efficacy in preventing mild to moderate obstructive sleep apnea, with improved tolerability relative to current therapy (i.e., CPAP).

**[0019]** The described devices, systems and methods are not limited to the specific embodiments described herein. In addition, components of each device, system and/or steps of each method may be practiced independent and separate from other components and method steps, respectively, described herein. Each component and method also can be used in combination with other systems and methods.

**[0020]** A therapeutic support apparatus 10 provides graduated lateral rotation of a sleep surface 11, along with other positional therapies, e.g. elevated head-of-bed, and techniques to interrupt sleep disordered breathing. Users of analgesic machines that have risk of respi-

ratory depression are at a higher risk of "dead in bed" syndrome. By combining one or more techniques for managing sleep disordered breathing, the therapeutic support apparatus 10 provides interventions to minimize user discomfort (and maximize user adherence to the therapy) while ensuring that the user will be effectively treated in the management of their sleep disorder. The therapeutic support apparatus 10 monitors the user for sleep disordered breathing and activates therapy based on user's sleep environment, immediate or historic efficacy of therapies, and available interventions. In some embodiments, one or more physical interventions may be utilized to manage sleep disordered breathing.

**[0021]** Referring to Fig. 1, therapeutic support apparatus 10 includes a frame 12 and a user support surface 14 positioned on the frame 12. The therapeutic support apparatus 10 may be a hospital bed or a standard bed, e.g. a bed at a user's home or at a care facility. The frame 12 includes a head section 16, a torso section 18 extending from the head section 16, and a foot section 20 extending from the torso section 18. In some embodiments, the frame 12 may include at least one actuator (not shown) to move the head section 16, torso section 18, and foot section 20 relative to one another. For example, the frame 12 may be moveable between a flat position, a Trundelburg position, and/or a head-up position. The user support surface 14 is illustrated as a mattress; however other user support surfaces may be positioned on the frame 12. In an embodiment where the frame 12 is moveable, the user support surface 14 moves with the frame 12. The user support surface 14 includes a head support surface 22 positioned under the head section 16, a torso support surface 24 positioned under the torso section 18, and a foot support surface 26 positioned under the foot section 20, which collectively form the sleep surface 11.

**[0022]** An elevation unit 28 is positioned between the user support surface 14 and the frame 12. In the illustrative embodiment, the elevation unit 28 is positioned under the head support surface 22 and the torso support surface 24. In some embodiments, the elevation unit 28 may also be positioned under the foot support surface 26. The elevation unit 28 is secured to the frame 12 at least one strap 30. The elevation unit 28 includes a plurality of inflatable bladders 32. In the illustrative embodiment, the elevation unit 28 includes a left head bladder 34, a right head bladder 36, a left torso bladder 38, and a right torso bladder 40. In some embodiments, the elevation unit 28 may also include foot bladders (not shown). The bladders 32 are fluidly coupled to an air system 42 that includes a pump to inflate and deflate the bladders 32. Each bladder 34, 36, 38, and 40 is coupled to the air system 42 via a respective hose 44, 46, 48, and 50.

**[0023]** The bladders 32 are operable to inflate and deflate to a desired capacity to angle the user support surface 14. The left head bladder 34 and the right head bladder 36 are operable to inflate and deflate to move the head support surface 22 to a desired head angle. In some

embodiments, only one of the left head bladder 34 and the right head bladder 36 is inflated to create the head angle of the head support surface 22. The left torso bladder 38 and the right torso bladder 40 are operable to inflate and deflate to move the torso support surface 24 to a desired torso angle. In some embodiments, only one of the left torso bladder 38 and the right torso bladder 40 is inflated to create the torso angle of the torso support surface 24. The head angle and the torso angle may combine to create a compound angle of the user support surface 14. In the embodiment shown in Fig. 2, the right head bladder 36 is inflated to a greater capacity than the left head bladder 34, and the right torso bladder 40 is inflated to a greater capacity than the left torso bladder 38 to angle a right side 52 of the user support surface 14 higher than a left side 54 of the user support surface 14. In the embodiment shown in Fig. 3, the left head bladder 34 is inflated to a greater capacity than the right head bladder 36, and the left torso bladder 38 is inflated to a greater capacity than the right torso bladder 40 to angle the left side 54 of the user support surface 14 higher than the right side 52 of the user support surface 14. In other embodiments, only the left head bladder 34 and the right head bladder 36 are inflated to create a head angle, while the left torso bladder 38 and the right torso bladder 40 are left entirely deflated so that the torso support surface 24 is flat.

**[0024]** Therapeutic support apparatus 10 also includes a control system 60 and a handheld control pendant 62. Control system 60 is removably attached to a footboard of the frame 12 and handheld control pendant 62 is removably attached to a siderail of the frame 12. The handheld control pendant 62 is illustrated as being coupled to the control system 60 by a wire; however, the handheld control pendant 62 may remotely communicate with the control system 60 using infrared, wireless, Bluetooth, or the like. Thus, elevation unit 28, control system 60, and handheld control pendant 62 are all coupled to each other and transferrable to different beds. The control system 60 includes a suitable computer-implemented control system that is operatively coupled to air system 42, such as in operational control communication with air system 42. Air system 42 includes electronics, valves, and one or more compressors necessary to introduce and remove air from the bladders 32 of elevation unit 28. Control system 60 has a user interface 64 to allow a user or caregiver to control elevation unit 28 with air system 42. In some embodiments the control system 60 or handheld control pendant 62 includes a timer that communicates with the air system 42. During a time period in which a user typically takes to fall asleep, the elevation unit 28 is controlled to be in the flat or collapsed positions and thereafter, the components of air system 42 operate to slowly inflate at least one of bladders 32 to preset therapeutic head and/or torso angles over a predetermined span of time. The angle of elevation unit 28 is individually selectable with handheld control pendant 62.

**[0025]** The control system 60 includes one or more

processors 70 and one or more sleep monitors 72, such as one or more sensors, coupled in signal communication with processors 70. Sleep monitors 72 are configured to monitor the user's sleep patterns and transmit signals indicative of the sensed sleep patterns to processors 70 for manipulation and evaluation of the data. Based at least in part on the one or more signals received from one or more sleep monitors 72, control system 60 is configured to expand or contract the elevation unit 28 to reposition the user during sleep to prevent or limit the occurrence of a sleep apnea episode, for example.

**[0026]** In certain embodiments as described herein, therapeutic support apparatus 10 is a dynamic support system, rather than a static support system, that is configured to control the configuration of sleep surface 11 based at least in part on data entered into control system 60 and/or sensed by one or more sleep monitors 72, for example, to improve the performance of sleep surface 11 in terms of clinical efficacy and user tolerability.

**[0027]** The therapeutic support apparatus 10 includes, in addition to other components, a plurality of sleep monitors 72 configured to sense and monitor various activities including without limitation, the user's body position, a location of the user with respect to sleep surface 11, an orientation, for example, a left side orientation or a right side sleep orientation, of the user, the user's vital signs including his/her sleep state, and additional relevant user activity during sleep. Each sleep monitor 72 is in signal communication with processors 70 configured to gather relevant data and generate and transmit to processors 70 signals indicative of the data gathered. Sleep monitors 72 are also configured to receive operation control signals from processors 70.

**[0028]** In some embodiments, the sleep monitor 72 may be a pulse monitor, e.g. an electronic heart monitor, to monitor the user's heart rate. The sleep monitor 72 may be at least one of an electrocardiogram, a photoplethysmogram, or an accelerometer to monitor respiratory rate and/or respiratory amplitude. Alternatively, or in addition to, the electrocardiogram and or an electroencephalograph may monitor the user's sleep state. The sleep monitor 72 may include a scale or positional sensor to determine the user's head angle and/or torso angle. Additionally, cameras and/or bed scales may monitor the user's position while sleeping. In some embodiments, the sleep monitor 72 may also include a microphone to monitor the user's snoring.

**[0029]** Data received from sleep monitors 72 is analyzed and operational control signals are transmitted to elevation unit 28 as well as to other components of therapeutic support apparatus 10, such as to air system 42 to activate air system 42 to provide air to elevation unit 28 and/or remove air from elevation unit 28 to adjust sleep surface 11 based on signals generated by sleep monitors 72 and analyzed by processors 70. In one embodiment, control system 60 includes suitable memory to store data sensed and/or generated by sleep monitors 72.

**[0030]** The therapeutic support apparatus 10 may also

include at least one alarm 74 to provide alerts based on data from the sleep monitors 72. The alarm 74 may include an audible alarm positioned near the therapeutic support apparatus 10 to alert the user of the therapeutic support apparatus 10. Alternatively, or in addition to, an audible alarm 74 may be provided remotely from the therapeutic support apparatus 10 to alert a caregiver. In some embodiments, the alarm 74 may include a visual alarm, for example a visual indicator at a nurse's station, an alert on a television at the user's home, etc. The alarm 74 functions to alert either the user of the therapeutic support apparatus 10 and/or the user's caregiver when a sleep disorder is detected by at least one of the sleep monitors 72.

**[0031]** Referring to Fig. 4-8, the elevation unit 28 includes first plate 79 coupled to a second plate 80 at a hinge 81 and a third plate 82 coupled to the second plate 80 at a hinge 83. Although described as plates, the plate 79, 80, 82 may be formed from a flexible semi-rigid material, e.g. plastic. The left head bladder 34 and left torso bladder 38 are positioned between the first plate 79 and the second plate 80. The second plate 80 moves relative to the first plate 79 when at least one of the left head bladder 34 and left torso bladder 38 is inflated. At least one expandable tether 84 may couple the first plate 79 to the second plate 80 to maintain a position of the first plate 79 relative to the second plate 80. The right head bladder 36 and right torso bladder 40 are positioned between the second plate 80 and the third plate 82. The third plate 82 moves relative to the second plate 80 when at least one of the right head bladder 36 and right torso bladder 40 is inflated. At least one expandable tether 85 (shown in Fig. 8) may couple the second plate 80 to the third plate 82 to maintain a position of the third plate 82 relative to the second plate 80.

**[0032]** The bladders 32 are distributed between a left side 90 and a right side 92 of the elevation unit. The left head bladder 34 is positioned adjacent the head end 86 and the left side 90. The right head bladder 36 is positioned adjacent the head end 86 and the right side 92. The left torso bladder 38 is positioned adjacent the torso end 88 and the left side 90. The right torso bladder 40 is positioned adjacent the torso end 88 and the right side 92. An envelope 94 encases the bladders 32 and the plates 79, 80, 82. The envelope 94 is formed from a flexible material and forms a bellows that expands and contracts as the plates 79, 80, 82 move relative to one another.

**[0033]** Sleep monitors 72 in the form of displacement monitors 96 are positioned within the elevation unit 28. In the illustrative embodiment, the monitors 96 are coupled to the third plate 82 to monitor a position of the third plate 82. The monitors 96 may be accelerometers or any other suitable monitor for determining position. A head monitor 98 is positioned between the left head bladder 34 and the right head bladder 36 to monitor a head angle of the elevation unit 28. A torso monitor 100 is positioned between the left torso bladder 38 and the right torso bladder

40 to monitor a torso angle of the elevation unit 28. It should be noted that the monitors 96 may be positioned at other locations to provide data related to the head angle and the torso angle of the elevation unit 28.

**[0034]** Hoses 44, 46, 48, and 50 extend from the elevation unit 28. In the illustrative embodiment, hoses 44, 46, 48, and 50 extend from the elevation unit 28. The hoses 44, 46, 48, and 50 extend so that the hoses 44, 46, 48, and 50 may be extended over a head end of the therapeutic support apparatus 10 without interfering with a user sleeping on the user support surface 14. In other embodiments, the hoses 44, 46, 48, and 50 may extend from any other portion of the elevation unit 28. Hose 44 fluidly couples to left head bladder 34, hose 46 fluidly couples to right head bladder 36, hose 48 fluidly couples to left torso bladder 38, and hose 50 fluidly couples to right torso bladder 40. Each of the hoses 44, 46, 48, and 50 is fluidly coupled to the air system 42 to supply air to left head bladder 34, right head bladder 36, left torso bladder 38, and right torso bladder 40.

**[0035]** Fig. 5 illustrates the elevation unit 28 as viewed from the head end 86. In the embodiment shown in Fig. 5, the head side of the envelope 94 has been removed to illustrate the bladders 32. The right head bladder 36 is inflated to raise the third plate 82 relative to the second plate 80. Notably, the right torso bladder 40 (not shown in Fig. 5) may also be inflated. The third plate 82 is raised from the second plate 80 to form the head angle. In the illustrative embodiment, the left head bladder 34 and the left torso bladder 38 (not shown in Fig. 5) are completely deflated. In other embodiments, the left head bladder 34 and the left torso bladder 38 may be partially inflated to provide additional support to the third plate 82. The tether 85 may facilitate maintaining a position of the third plate 82 relative to the second plate 80. A right side of the envelope 94 is illustrated in Fig. 5. The envelope 94 expands with the elevation unit 28 in a bellows-like manner such that the bladders 32 remain positioned within the envelope 94.

**[0036]** Referring to Fig. 6, the elevation unit 28 is illustrated from the right side 92. The right head bladder 36 is inflated to a first capacity. The right torso bladder 40 is inflated to a second capacity that is less than the first capacity. By inflating the right head bladder 36 to a greater capacity than the right torso bladder 40, while deflating the left head bladder 34 and the left torso bladder 38, the third plate 82 forms a compound angle defined by the head angle and a torso angle, as illustrated in Fig. 7. Again, it should be noted that the left head bladder 34 and the left torso bladder 38 may also be inflated for additional support. In such an embodiment, the left head bladder 34 is inflated to a lesser capacity than the right head bladder 36, and the left torso bladder 38 is inflated to a lesser capacity than the right torso bladder 40. The embodiments illustrated in Figs. 4-7 show the right side 92 of the elevation unit 28 inflated to raise the right side 52 of the user support surface 14 higher than the left side 54 of the user support surface 14, as illustrated in Fig. 2.

In the embodiment shown in Fig. 8, the elevation unit 28 is inflated to raise the left side 54 of the user support surface 14 higher than the right side 52 of the user support surface 14, as illustrated in Fig. 3, i.e. the second plate 80 is raised relative to the first plate 79. The head angle and torso angle of the elevation unit 28 may be predetermined to address the user's sleep apnea and reduce oxygen desaturation during sleep.

**[0037]** An exemplary method 200 utilizing control system 60 for monitoring the sleep activities of a user positioned on therapeutic support apparatus 10 is illustrated in FIG. 9. The method 200 also includes steps for controlling the user's sleep apnea and reducing oxygen desaturation. As described above, control system 60 includes one or more processors 70 configured to perform the steps as described herein.

**[0038]** Control system 60 is activated 202 to position the user at angles to reduce apnea episodes. For example, the angles may be selected to facilitate preventing oxygen desaturation. The head section 16 may be positioned at a predetermined head angle and the torso section 18 may be positioned at a predetermined torso angle. The sections 16 and 18 may be angled manually by the user or a caregiver. For example, when the user wants to go to sleep, the sections 16 and 18 are manually angled for a desired sleep position. Alternatively, the sections 16 and 18 may automatically angle to the desired sleep position when user sleep is detected by the control system 60. In one embodiment, control system 60 detects 204 when the user begins to fall asleep and activates 206 therapeutic support apparatus 10 on a delay to rotate the user at a suitable time after sleep is detected, such as after the user has been asleep for 30 minutes. In an alternative embodiment, control system 60 is programmed to activate therapeutic support apparatus 10 at a preset time, for example, at a 30 minute delay, without relying on monitoring the user's sleep activity. In a particular embodiment, control system 60 delays inter-sleep rotation of the user until the user is in a deep sleep. Further, when control system 60 detects that the user is waking, control system 60 will activate therapeutic support apparatus 10 to move mattress 14 to an initial configuration such that the user can exit from mattress 14. In a further embodiment, control system 60 prevents activation of therapeutic support apparatus 10 if control system 60 detects the user is sleeping in a lateral decubitus position.

**[0039]** Prior to sleep, the user is able to input 208 to control system 60 sleep data including without limitation, preferred sleeping sides and positions, the user's measurements including, for example, the user's height, weight, and inseam and torso measurements, preferred lateral rotational angles and/or longitudinal rotational angles of one or more support planes defining the sleep surface 11. Based at least in part on the user's input data, control system 60 is configured to activate therapeutic support apparatus 10 to adjust a direction and/or a level of rotation of one or more support planes defining the

sleep surface 11. For example, if the user prefers a left side slope to sleep surface 11, control system 60 activates elevation unit 28 to form the desired lateral left side slope, or if the user's partner is sleeping on the left side of the user, a left angle may be created. In one embodiment, minimal adjustments are made to sleep surface 11 to maintain the user's apnea-hypopnea index under 5 and/or prevent snoring because apnea events and snoring may or may not be equivalent, depending on the user.

**[0040]** During sleep, control system 60 actively monitors 210 the user's vital signs and other relevant sleep data. Control system 60 is configured to collect and record data obtained as the user sleeps to diagnose any undesirable or abnormal sleep activities or conditions, including the user's apnea-hypopnea index, for example. The vital signs monitored may include respiratory rate, respiratory amplitude, heart rate, and/or oxygen saturation (SpO<sub>2</sub>). In some embodiments, the control system 60 may be configured to monitor other user vital signs. Other relevant sleep data may include measurements of the user's head angle and torso angle, the user's apnea-hypopnea index, the user's sleep state, and/or snoring. In some embodiments, other relevant sleep data may be monitored. If the control system 60 monitors adverse sleep data, e.g. abnormally high or low heart rate, abnormally high or low respiratory rate, apnea-hypopnea index above 5, etc., the control system 60 automatically responds to the adverse sleep data to prevent oxygen desaturation. If the user is sensed to be suffering from sleep disordered breathing based on sensed apnea, sensed irregular breathing pattern, breath interruption, sound of snoring, O<sub>2</sub> desaturation, inadequate head rotation or the like the control 150 may automatically increase 212 a lateral angle of at least one of the head section 16 and the torso section 18 by operating the elevation unit 28 while preserving the user's sleep state. For example, if the head angle of the head section 16 is at 17.5 degrees and the torso angle of the torso section 18 is at 12.5 degrees torso, the angles may be insufficient to manage the user's sleep apnea. Accordingly, at least one of the head angle and the torso angle are slowly increased. For example, the head angle may be increased to 20 degrees and/or the torso angle may be increased to 15 degrees. The control system 60 gradually increases the head angle and the torso angle such that the user's sleep state is uninterrupted.

**[0041]** If altering the lateral angles of the sleep surface 11 fails to improve the user's condition, the lateral angle of at least one of the head section 16 and the torso section 18 may be increased or decreased abruptly 214 to arouse user from the user's current sleep stage, up to and including waking the user. Alternatively, or in addition to, the bead frame 12 or mattress 14 may be vibrated to arouse the user. In some embodiments, the head of the bed frame may be raised to arouse the user. Disturbing the user's sleep may change the user's sleep state, e.g. waking them from sleep stage 3 to sleep stage 1, or all

the way to awake. Changes in the user's sleep state (not necessarily awakening the user) may be sufficient to trigger a sympathetic/arousal response that will make the user breath normally. As sleep disordered breathing may be a function of sleep stage, sleep disordered breathing suffered in sleep stage 3 or sleep stage 4 may be resolved if and when user enters sleep stage 1, sleep stage 2, or REM sleep.

**[0042]** If altering the user's sleep state fails to improve the user's condition, the control system 60 may activate 216 alarm 74. Initially, the control system 60 activates a local alarm 74 that is proximate to the therapeutic support apparatus 10 and the user. Activating the local alarm 74 may arouse the user and alter a sleep state of the user as described above. Alternatively, activating 218 the local alarm 74 may entirely wake the user. If the local alarm 74 fails to arouse or wake the user, the control system 60 may activate 220 other remote alarms to notify a caregiver of the adverse sleep condition of the user. The caregiver may then arouse or wake the user to control the adverse sleep condition.

**[0043]** Any theory, mechanism of operation, proof, or finding stated herein is meant to further enhance understanding of principles of the present disclosure and is not intended to make the present disclosure in anyway dependent upon such theory, mechanism of operation, illustrative embodiment, proof, or finding. It should be understood that while the use of the word preferable, preferably or preferred in the description above indicates that the feature so described can be more desirable, it nonetheless cannot be necessary and embodiments lacking the same can be contemplated as within the scope of the disclosure, that scope being defined by the claims that follow.

## Claims

### 1. A therapeutic support apparatus (10) comprising:

a user support surface (14) extending along a longitudinal axis, the user support surface (14) having a head section (16) and a torso section (18), each of the head section (16) and the torso section (18) being operable to angle relative to the longitudinal axis,  
 an elevation unit (28) operable to position at least one of the head section (16) and torso section (18) at angles relative to the longitudinal axis,  
 a monitor to acquire data related to a user while sleeping on the user support surface (14), and an alarm (74) operable to activate based on the data acquired by the monitor,  
 wherein at least one of the elevation unit (28) and the alarm (74) is activated in response to the data acquired by the monitor to control oxygen desaturation of the user, wherein the eleva-

tion unit (28) includes:

a first plate (79) couple to a second plate (80) at a hinge (81), and  
 at least one inflatable bladder (32) positioned between the first plate (79) and the second plate (80),

wherein the at least one inflatable bladder (32) is operable to inflate and deflate to move the second plate (80) to an angle relative to the first plate (79),

wherein the at least one inflatable bladder (32) includes a head bladder (32, 34) and a torso bladder (38, 40),

wherein the head bladder (32, 34) is operable to inflate and deflate to move a head section (16) of the second plate (80) to a head angle relative to the first plate (79), and

wherein the torso bladder (38, 40) is operable to inflate and deflate to move a torso section (18) of the second plate (80) to a torso angle relative to the first plate (79).

2. The therapeutic support apparatus (10) of claim 1, wherein the head angle and the torso angle are different.
3. The therapeutic support apparatus (10) of either claim 1 or claim 2, wherein the head section (16) of the second plate (80) and the torso section (18) of the second plate (80) cooperate to form a compound angle.
4. The therapeutic support apparatus (10) of any one of claims 1 to 3, wherein the elevation unit (28) changes a head angle of the head section (16) of the second plate (80) in response to the data acquired by the monitor and/or wherein the elevation unit (28) changes the torso angle of the torso section (18) of the second plate (80) in response to the data acquired by the monitor.
5. The therapeutic support apparatus (10) of any one of claims 1 to 3, wherein the elevation unit (28) moves the head section (16) of the second plate (80) in response to the data acquired by the monitor to alter a sleep stage of the user and/or wherein the elevation unit (28) moves the torso section (18) of the second plate (80) in response to the data acquired by the monitor to alter a sleep stage of the user.
6. The therapeutic support apparatus (10) of any one of claims 1 to 5, wherein the elevation unit (28) includes an expandable envelope (94), wherein the first plate (79), the second plate (80), and the at least one inflatable bladder (32) are housed within the expandable envelope (94).

7. A therapeutic support apparatus (10) comprising:

a user support surface (14) extending along a longitudinal axis, the user support surface (14) having a head section (16) and a torso section (18), each of the head section (16) and the torso section (18) being operable to angle relative to the longitudinal axis,

an elevation unit (28) operable to position at least one of the head section (16) and torso section (18) at angles relative to the longitudinal axis,

a monitor to acquire data related to a user while sleeping on the user support surface (14), and an alarm (74) operable to activate based on the data acquired by the monitor, wherein at least one of the elevation unit (28) and the alarm (74) is activated in response to the data acquired by the monitor to control oxygen desaturation of the user,

wherein the elevation unit (28) includes:

a first plate (79) coupled to a second plate (80) at a first hinge (81),

a third plate (82) coupled to the second plate (80) at a second hinge (83),

at least one inflatable right bladder (36, 40) positioned between the first plate (79) and the second plate (80), and

at least one inflatable left bladder (34, 38) positioned between the second plate (80) and the third plate (83),

wherein the at least one inflatable right bladder (36, 40) is operable to inflate and deflate to move the second plate (80) to an angle relative to the first plate (79), and

wherein the at least one inflatable left bladder (34, 38) is operable to inflate and deflate to move the third plate (83) to an angle relative to the second plate (80).

8. The therapeutic support apparatus (10) of claim 7, wherein the first plate (79), the second plate (80), and the third plate (83) are formed from a flexible material.

9. The therapeutic support apparatus (10) of either claim 7 or claim 8, wherein the at least one inflatable right bladder (36, 40) includes a right head bladder (36) and a right torso bladder (40), wherein the right head bladder (36) is operable to inflate and deflate to move a head section (16) of the second plate (80) to a head angle relative to the first plate (79), and wherein the right torso bladder (40) is operable to inflate and deflate to move a torso section (18) of the second plate (80) to a torso angle relative to the first

plate (79).

10. The therapeutic support apparatus (10) of any one of claims 7 to 9, wherein the at least one inflatable left bladder (34, 38) includes a left head bladder (34) and a left torso bladder (38), wherein the left head bladder (34) is operable to inflate and deflate to move a head section (16) of the second plate (80) to a head angle relative to the first plate (79), and wherein the left torso bladder (38) is operable to inflate and deflate to move a torso section (18) of the second plate (80) to a torso angle relative to the first plate (79).

11. The therapeutic support apparatus (10) of either claim 9 or claim 10, wherein:

the head bladder (34, 36) is operable to inflate and deflate to a first capacity, and the torso bladder (38, 40) is operable to inflate and deflate to a second capacity, wherein the first capacity is different than the second capacity,

the head bladder (34, 36) and the torso bladder (38, 40) cooperate to form a compound angle.

12. The therapeutic support apparatus (10) of any preceding claim, wherein the data acquired includes at least one of head angle and torso angle.

13. The therapeutic support apparatus (10) of any preceding claim, wherein the data acquired includes at least one of respiratory rate, respiratory amplitude, oxygen saturation, apnea hypopnea index, sleep state, and snoring.

#### Patentansprüche

1. Eine therapeutische Stützvorrichtung (10), umfassend:

eine Benutzerstützoberfläche (14), die sich entlang einer Längsachse erstreckt, wobei die Benutzerstützoberfläche (14) über einen Kopfabschnitt (16) und einen Rumpfabschnitt (18) verfügt, wobei der Kopfabschnitt (16) und der Rumpfabschnitt (18) jeweils bedienbar sind, sich relativ zur Längsachse auszurichten, eine Anhebeeinheit (28), die bedienbar ist, um mindestens einen von dem Kopfabschnitt (16) und dem Rumpfabschnitt (18) in Winkeln relativ zur Längsachse zu positionieren, einen Monitor, um Daten zu erfassen, die sich auf einen Benutzer beim Schlafen auf der Benutzerstützoberfläche (14) beziehen, und einen Alarm (74), der bedienbar ist, um basierend auf den durch den Monitor erfassten Daten

aktiviert zu werden,  
wobei mindestens eines von der Anhebeeinheit (28) und dem Alarm (74) als Reaktion auf die durch den Monitor erfassten Daten aktiviert wird, um die Sauerstoffentsättigung des Benutzers zu kontrollieren, wobei die Anhebeeinheit (28) Folgendes beinhaltet:

eine erste Platte (79), die mit einem Scharnier (81) an eine zweite Platte (80) gekoppelt ist, und  
mindestens eine befüllbare Blase (32), die zwischen der ersten Platte (79) und der zweiten Platte (80) positioniert ist,

wobei die mindestens eine befüllbare Blase (32) zum Befüllen und Entleeren bedienbar ist, um die zweite Platte (80) in einen Winkel relativ zur ersten Platte (79) zu bewegen,  
wobei die mindestens eine befüllbare Blase (32) eine Kopfblase (32, 34) und eine Rumpfbhase (38, 40) beinhaltet,  
wobei die Kopfblase (32, 34) zum Befüllen und Entleeren bedienbar ist, um einen Kopfabschnitt (16) der zweiten Platte (80) in einen Kopfwinkel relativ zur ersten Platte (79) zu bewegen, und  
wobei die Rumpfbhase (38, 40) zum Befüllen und Entleeren bedienbar ist, um einen Rumpfabschnitt (18) der zweiten Platte (80) in einen Rumpfwinkel relativ zur ersten Platte (79) zu bewegen.

2. Die therapeutische Stützvorrichtung (10) nach Anspruch 1, wobei sich der Kopfwinkel und der Rumpfwinkel unterscheiden.
3. Die therapeutische Stützvorrichtung (10) nach entweder Anspruch 1 oder Anspruch 2, wobei der Kopfabschnitt (16) der zweiten Platte (80) und der Rumpfabschnitt (18) der zweiten Platte (80) zusammenwirken, um einen zusammengesetzten Winkel zu bilden.
4. Die therapeutische Stützvorrichtung (10) nach einem der Ansprüche 1 bis 3, wobei die Anhebeeinheit (28) einen Kopfwinkel des Kopfabschnitts (16) der zweiten Platte (80) als Reaktion auf die durch den Monitor erfassten Daten ändert und/oder wobei die Anhebeeinheit (28) den Rumpfwinkel des Rumpfabschnitts (18) der zweiten Platte (80) als Reaktion auf die durch den Monitor erfassten Daten ändert.
5. Die therapeutische Stützvorrichtung (10) nach einem der Ansprüche 1 bis 3, wobei die Anhebeeinheit (28) den Kopfabschnitt (16) der zweiten Platte (80) als Reaktion auf die durch den Monitor erfassten Daten bewegt, um einen Schlafzustand des Benutzers zu verändern und/oder wobei die Anhebeeinheit (28)

den Rumpfabschnitt (18) der zweiten Platte (80) als Reaktion auf die durch den Monitor erfassten Daten bewegt, um einen Schlafzustand des Benutzers zu verändern.

6. Die therapeutische Stützvorrichtung (10) nach einem der Ansprüche 1 bis 5, wobei die Anhebeeinheit (28) eine ausdehnbare Hülle (94) beinhaltet, wobei die erste Platte (79), die zweite Platte (80) und die mindestens eine befüllbare Blase (32) in der ausdehnbaren Hülle (94) untergebracht sind.
7. Eine therapeutische Stützvorrichtung (10), umfassend:

eine Benutzerstützoberfläche (14), die sich entlang einer Längsachse erstreckt, wobei die Benutzerstützoberfläche (14) über einen Kopfabschnitt (16) und einen Rumpfabschnitt (18) verfügt, wobei der Kopfabschnitt (16) und der Rumpfabschnitt (18) jeweils bedienbar sind, sich relativ der Längsachse auszurichten, eine Anhebeeinheit (28), die bedienbar ist, um mindestens einen von dem Kopfabschnitt (16) und dem Rumpfabschnitt (18) in Winkeln relativ zur Längsachse zu positionieren, einen Monitor, um Daten zu erfassen, die sich auf einen Benutzer beim Schlafen auf der Benutzerstützoberfläche (14) beziehen, und einen Alarm (74), der bedienbar ist, um basierend auf den durch den Monitor erfassten Daten aktiviert zu werden, wobei mindestens eines von der Anhebeeinheit (28) und dem Alarm (74) als Reaktion auf die durch den Monitor erfassten Daten aktiviert wird, um die Sauerstoffentsättigung des Benutzers zu kontrollieren, wobei die Anhebeeinheit (28) Folgendes beinhaltet:

eine erste Platte (79), die mit einem ersten Scharnier (81) an eine zweite Platte (80) gekoppelt ist,  
eine dritte Platte (82), die mit einem zweiten Scharnier (83) an die zweite Platte (80) gekoppelt ist,  
mindestens eine befüllbare rechte Blase (36, 40), die zwischen der ersten Platte (79) und der zweiten Platte (80) positioniert ist, und  
mindestens eine befüllbare linke Blase (34, 38), die zwischen der zweiten Platte (80) und der dritten Platte (83) positioniert ist,

wobei die mindestens eine befüllbare rechte Blase (36, 40) zum Befüllen und Entleeren bedienbar ist, um die zweite Platte (80) in einen Winkel relativ zur ersten Platte (79) zu bewegen,

- und  
wobei die mindestens eine befüllbare linke Blase (34, 38) zum Befüllen und Entleeren bedienbar ist, um die dritte Platte (83) in einen Winkel relativ zu der zweiten Platte (80) zu bewegen. 5
8. Die therapeutische Stützvorrichtung (10) nach Anspruch 7, wobei die erste Platte (79), die zweite Platte (80) und die dritte Platte (83) aus einem flexiblen Material geformt sind.
9. Die therapeutische Stützvorrichtung (10) nach entweder Anspruch 7 oder Anspruch 8, wobei die mindestens eine befüllbare rechte Blase (36, 40) eine rechte Kopfblase (36) und eine rechte Rumpfbase (40) beinhaltet,  
wobei die rechte Kopfblase (36) zum Befüllen und Entleeren bedienbar ist, um einen Kopfabschnitt (16) der zweiten Platte (80) in einen Kopfwinkel relativ zur ersten Platte (79) zu bewegen, und  
wobei die rechte Rumpfbase (40) zum Befüllen und Entleeren bedienbar ist, um einen Rumpfabschnitt (18) der zweiten Platte (80) in einen Rumpfwinkel relativ zur ersten Platte (79) zu bewegen.
10. Die therapeutische Stützvorrichtung (10) nach einem der Ansprüche 7 bis 9, wobei die mindestens eine befüllbare linke Blase (34, 38) eine linke Kopfblase (34) und eine linke Rumpfbase (38) beinhaltet, wobei die linke Kopfblase (34) zum Befüllen und Entleeren bedienbar ist, um einen Kopfabschnitt (16) der zweiten Platte (80) in einen Kopfwinkel relativ zur ersten Platte (79) zu bewegen, und  
wobei die linke Rumpfbase (38) zum Befüllen und Entleeren bedienbar ist, um einen Rumpfabschnitt (18) der zweiten Platte (80) in einen Rumpfwinkel relativ zur ersten Platte (79) zu bewegen.
11. Die therapeutische Stützvorrichtung (10) nach entweder Anspruch 9 oder Anspruch 10, wobei:  
  
die Kopfblase (34, 36) zum Befüllen und Entleeren bis zu einer ersten Kapazität bedienbar ist und die Rumpfbase (38, 40) zum Befüllen und Entleeren bis zu einer zweiten Kapazität bedienbar ist, wobei sich die erste Kapazität von der zweiten Kapazität unterscheidet,  
die Kopfblase (34, 36) und die Rumpfbase (38, 40) zusammenwirken, um einen zusammengesetzten Winkel zu bilden.
12. Die therapeutische Stützvorrichtung (10) nach einem der vorstehenden Ansprüche, wobei die erfassten Daten mindestens einen Datensatz bezüglich des Kopfwinkels und des Rumpfwinkels beinhalten.
13. Die therapeutische Stützvorrichtung (10) nach ei-

nem der vorstehenden Ansprüche, wobei die erfassten Daten mindestens einen Datensatz bezüglich Atemfrequenz, Atemamplitude, Sauerstoffsättigung, Apnoe-Hypopnoe-Index, Schlafzustand und Schnarchen beinhalten.

## Revendications

1. Appareil de support thérapeutique (10) comprenant :
- une surface de support utilisateur (14) s'étendant le long d'un axe longitudinal, la surface de support utilisateur (14) ayant une section de tête (16) et une section de torse (18), chacune de la section de tête (16) et la section de torse (18) pouvant s'incliner par rapport à l'axe longitudinal,
- une unité d'élévation (28) pouvant positionner au moins une section de tête (16) et une section de torse (18) à des angles par rapport à l'axe longitudinal,
- un moniteur permettant d'acquérir des données relatives à un utilisateur dormant sur la surface du support utilisateur (14), et
- une alarme (74) pouvant s'activer en fonction des données acquises par le moniteur, dans lequel au moins une parmi l'unité d'élévation (28) et l'alarme (74) est activée en réponse aux données acquises par le moniteur pour contrôler la désaturation en oxygène de l'utilisateur, l'unité d'élévation (28) incluant :
- une première plaque (79) couplée à une deuxième plaque (80) au niveau d'une charnière (81), et  
au moins une poche gonflable (32) placée entre la première plaque (79) et la deuxième plaque (80),
- dans lequel la au moins une poche gonflable (32) peut être gonflée et dégonflée pour déplacer la deuxième plaque (80) à un angle par rapport à la première plaque (79),
- dans lequel la au moins une poche gonflable (32) inclut une poche de tête (32, 34) et une poche de torse (38, 40),
- dans lequel la poche de tête (32, 34) peut être gonflée et dégonflée pour déplacer une section de tête (16) de la deuxième plaque (80) à un angle de tête par rapport à la première plaque (79), et
- dans lequel la poche de torse (38, 40) peut être gonflée et dégonflée pour déplacer une section de torse (18) de la deuxième plaque (80) à un angle de torse par rapport à la première plaque (79).

2. Appareil de support thérapeutique (10) selon la revendication 1, dans lequel l'angle de tête et l'angle de torse sont différents.
3. Appareil de support thérapeutique (10) selon la revendication 1 ou la revendication 2, dans lequel la section de tête (16) de la deuxième plaque (80) et la section de torse (18) de la deuxième plaque (80) coopèrent pour former un angle composé.
4. Appareil de support thérapeutique (10) selon l'une quelconque des revendications 1 à 3, dans lequel l'unité d'élévation (28) modifie un angle de tête de la section de tête (16) de la deuxième plaque (80) en réponse aux données acquises par le moniteur et/ou dans lequel l'unité d'élévation (28) modifie l'angle de torse de la section de torse (18) de la deuxième plaque (80) en réponse aux données acquises par le moniteur.
5. Appareil de support thérapeutique (10) selon l'une des revendications 1 à 3, dans lequel l'unité d'élévation (28) déplace la section de tête (16) de la deuxième plaque (80) en réponse aux données acquises par le moniteur pour modifier une phase de sommeil de l'utilisateur et/ou dans lequel l'unité d'élévation (28) déplace la section de torse (18) de la deuxième plaque (80) en réponse aux données acquises par le moniteur pour modifier une phase de sommeil de l'utilisateur.
6. Appareil de support thérapeutique (10) selon l'une quelconque des revendications 1 à 5, dans lequel l'unité d'élévation (28) inclut une enveloppe extensible (94), dans lequel la première plaque (79), la deuxième plaque (80) et la au moins une poche gonflable (32) sont logés dans l'enveloppe extensible (94).
7. Appareil de support thérapeutique (10) comprenant :
- une surface de support utilisateur (14) s'étendant le long d'un axe longitudinal, la surface de support utilisateur (14) ayant une section de tête (16) et une section de torse (18), chacune de la section de tête (16) et la section de torse (18) pouvant s'incliner par rapport à l'axe longitudinal,
  - une unité d'élévation (28) pouvant positionner au moins une section de tête (16) et une section de torse (18) à des angles par rapport à l'axe longitudinal,
  - un moniteur permettant d'acquérir des données relatives à un utilisateur dormant sur la surface du support utilisateur (14), et
  - une alarme (74) pouvant s'activer en fonction des données acquises par le moniteur, dans lequel au moins une parmi l'unité d'élévation (28)
- et l'alarme (74) est activée en réponse aux données acquises par le moniteur pour contrôler la désaturation en oxygène de l'utilisateur, dans lequel l'unité d'élévation (28) inclut :
- une première plaque (79) couplée à une deuxième plaque (80) au niveau d'une première charnière (81),
  - une troisième plaque (82) couplée à la deuxième plaque (80) au niveau d'une deuxième charnière (83),
  - au moins une poche droite gonflable (36, 40) placée entre la première plaque (79) et la deuxième plaque (80), et
  - au moins une poche gauche gonflable (34, 38) placée entre la deuxième plaque (80) et la troisième plaque (83),
- dans lequel au moins une poche gonflable droite (36, 40) peut être gonflée et dégonflée pour déplacer la deuxième plaque (80) à un angle par rapport à la première plaque (79), et dans lequel la au moins une poche gauche gonflable (34, 38) peut être gonflée et dégonflée pour déplacer la troisième plaque (83) à un angle par rapport à la deuxième plaque (80).
8. Appareil de support thérapeutique (10) selon la revendication 7, dans lequel la première plaque (79), la deuxième plaque (80) et la troisième plaque (83) sont formées à partir d'un matériau souple.
9. Appareil de support thérapeutique (10) selon la revendication 7 ou la revendication 8, dans lequel la au moins une poche droite gonflable (36, 40) inclut une poche droite de tête (36) et une poche droite de torse (40), dans lequel la poche droite de tête (36) peut être gonflée et dégonflée pour déplacer une section de tête (16) de la deuxième plaque (80) à un angle de tête par rapport à la première plaque (79), et dans lequel la poche droite de torse (40) peut être gonflée et dégonflée pour déplacer une section de torse (18) de la deuxième plaque (80) à un angle de torse par rapport à la première plaque (79).
10. Appareil de support thérapeutique (10) selon l'une quelconque des revendications 7 à 9, dans lequel la au moins une poche gauche gonflable (34, 38) inclut une poche gauche de tête (34) et une poche gauche de torse (38), dans lequel la poche gauche de tête (34) peut être gonflée et dégonflée pour déplacer une section de tête (16) de la deuxième plaque (80) à un angle de tête par rapport à la première plaque (79), et dans lequel la poche gauche de torse (38) peut être gonflée et dégonflée pour déplacer une section de torse (18) de la deuxième plaque (80) à un angle de

torse par rapport à la première plaque (79).

11. Appareil de support thérapeutique (10) selon la revendication 9 ou la revendication 10, dans lequel :

5

la poche de tête (34, 36) peut être gonflée et dégonflée à une première capacité, et la poche de torse (38, 40) peut être gonflée et dégonflée à une deuxième capacité, dans lequel la première capacité est différente de la deuxième capacité,

10

la poche de tête (34, 36) et la poche de torse (38, 40) coopèrent pour former un angle composé.

15

12. Appareil de support thérapeutique (10) selon l'une quelconque des revendications précédentes, dans lequel les données acquises incluent au moins un des angles de tête et de torse.

20

13. Appareil de support thérapeutique (10) selon l'une quelconque des revendications précédentes, dans lequel les données acquises incluent au moins un élément parmi une fréquence respiratoire, une amplitude respiratoire, une saturation en oxygène, un indice d'apnée-hypopnée, un état de sommeil et un ronflement.

25

30

35

40

45

50

55

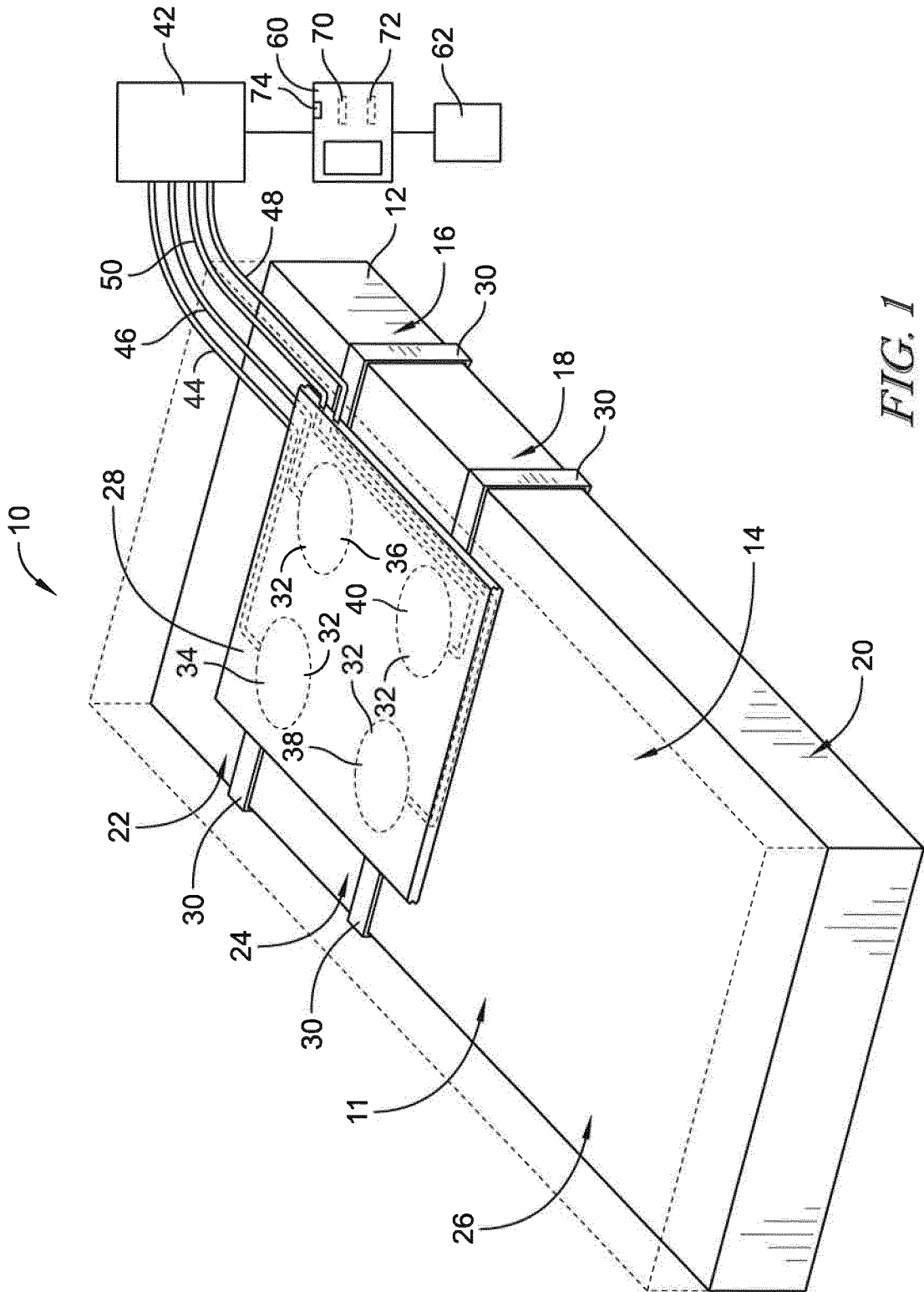

FIG. 1

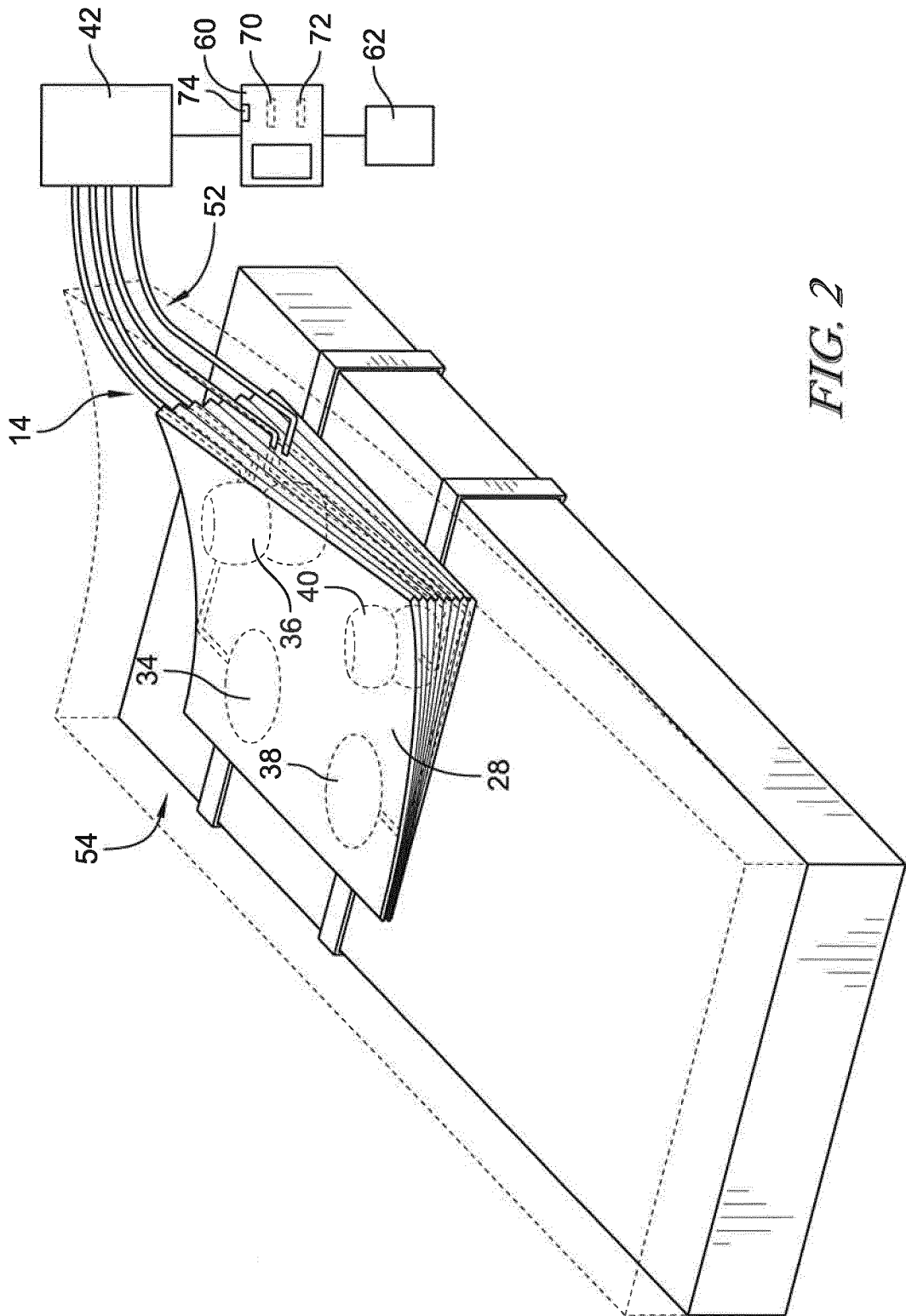
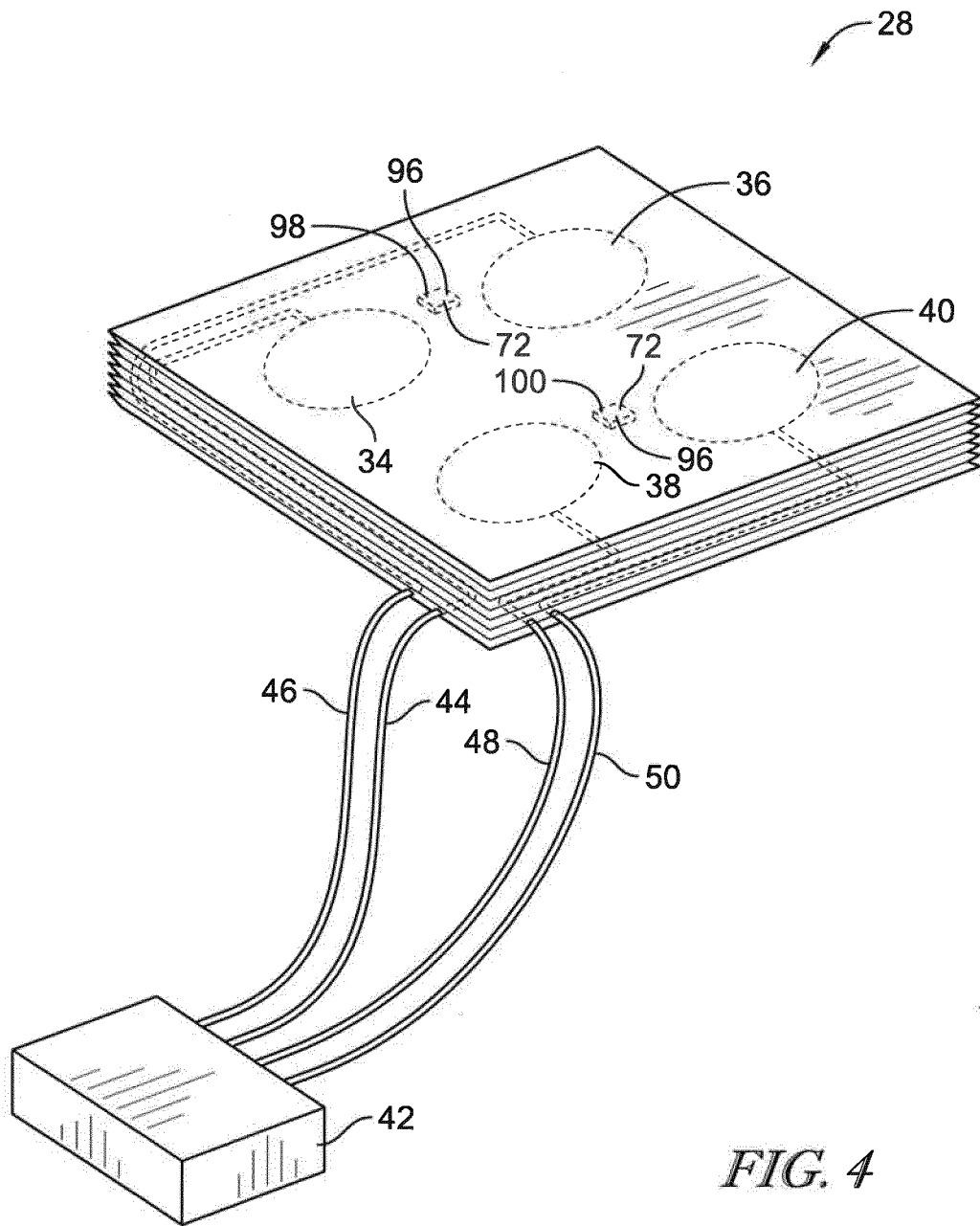

FIG. 2





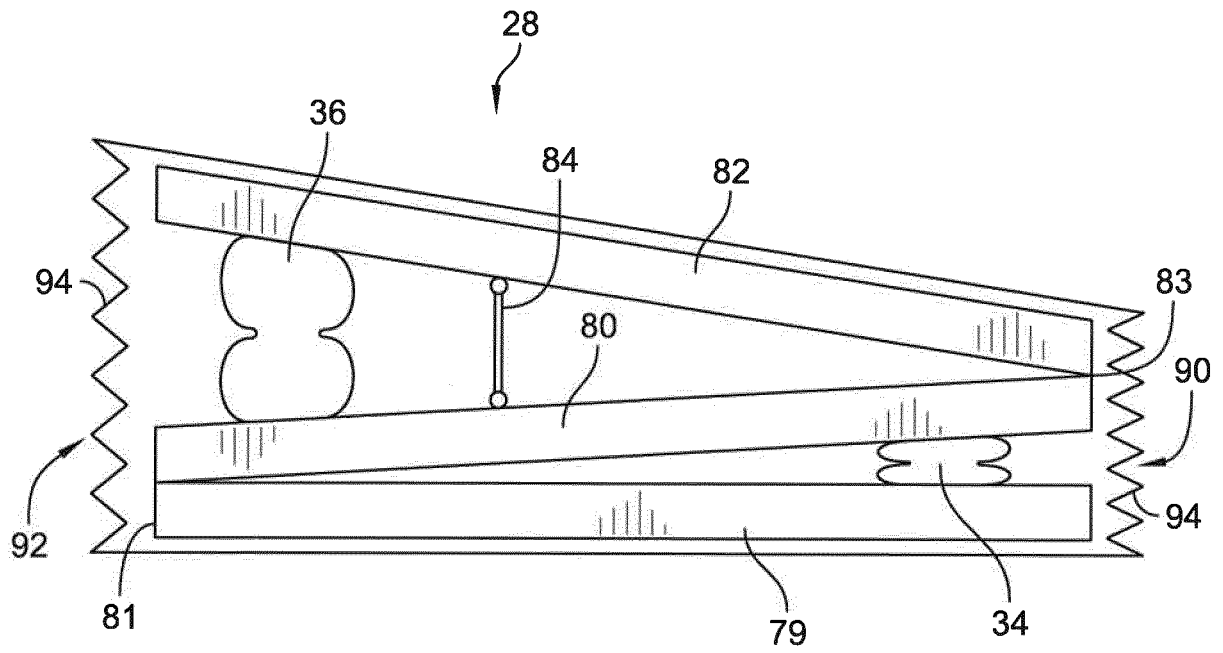

FIG. 5

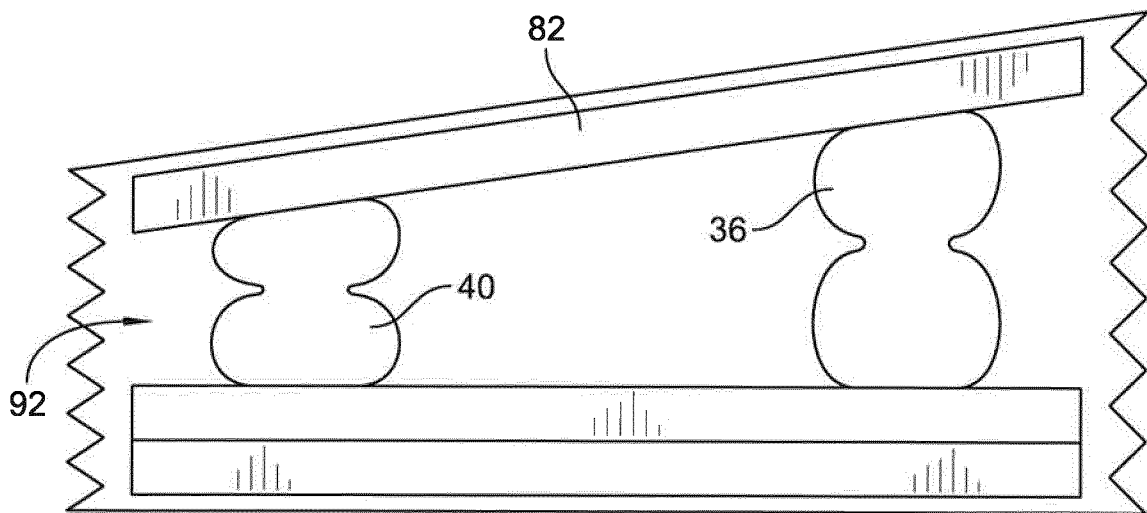

FIG. 6

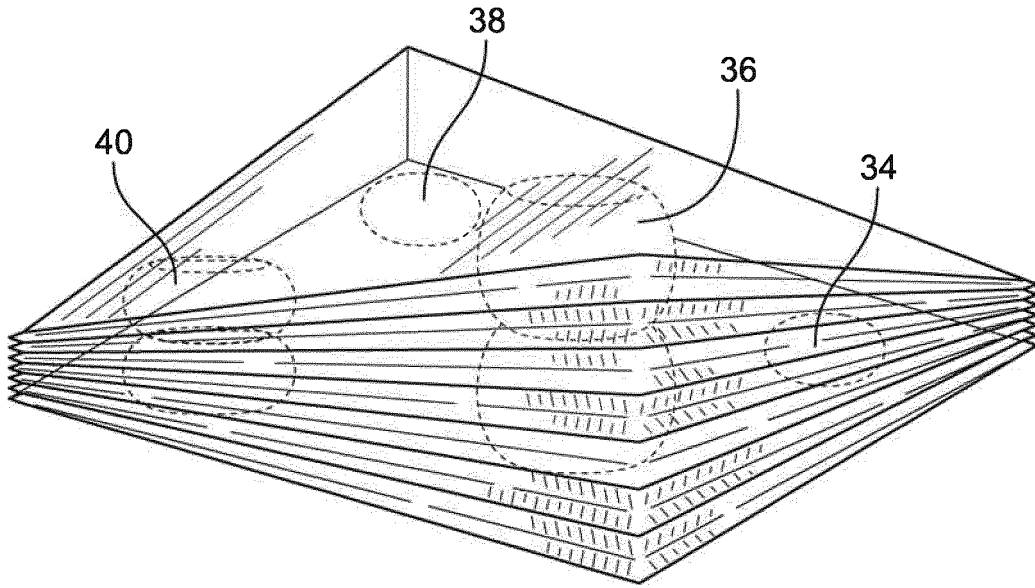

FIG. 7

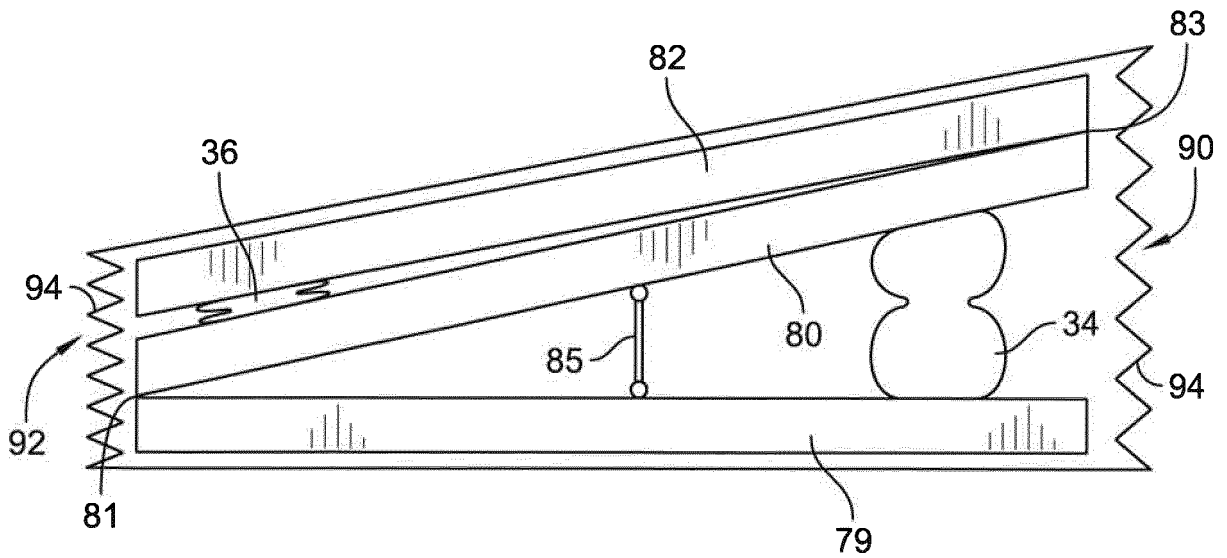

FIG. 8

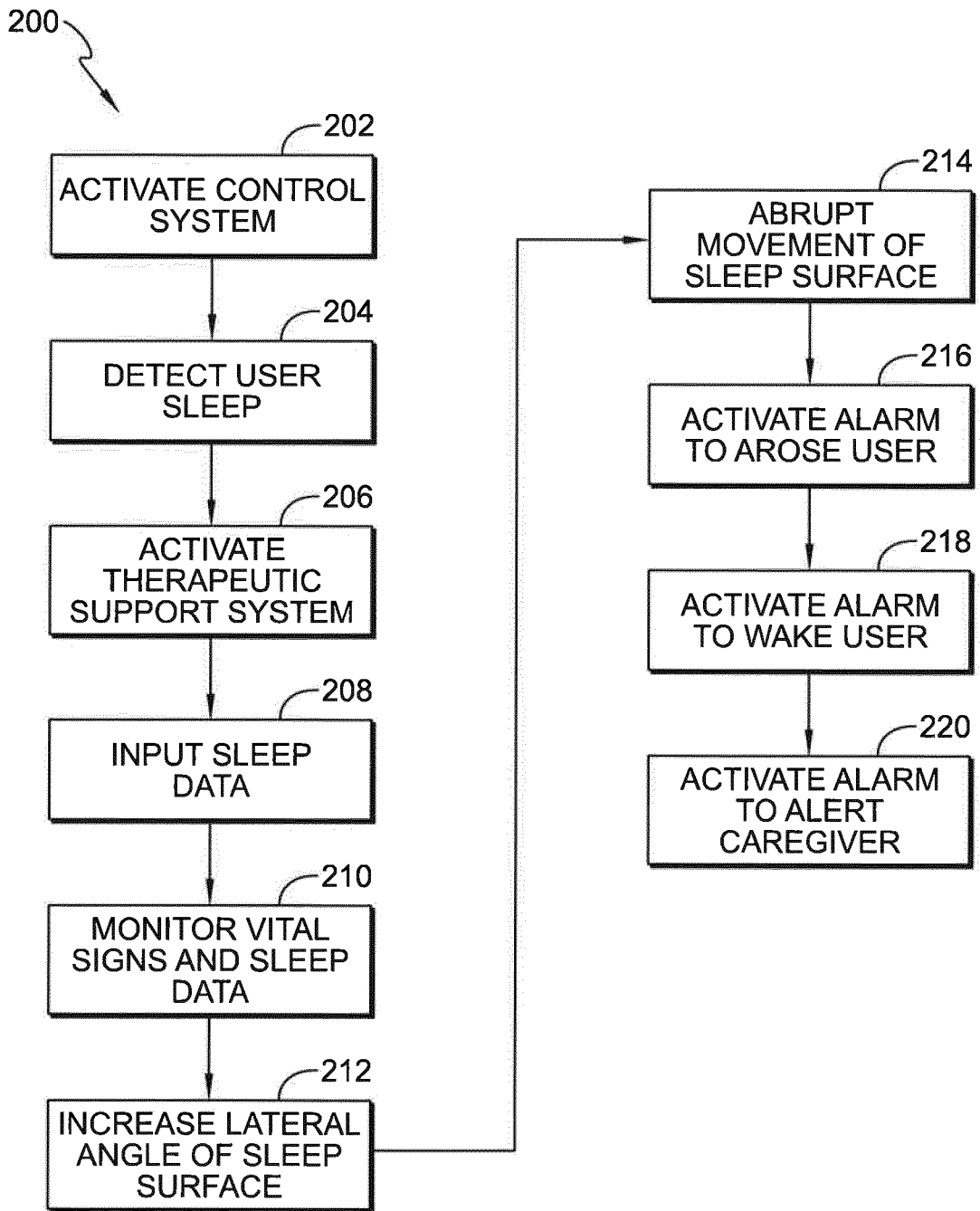

FIG. 9

**REFERENCES CITED IN THE DESCRIPTION**

*This list of references cited by the applicant is for the reader's convenience only. It does not form part of the European patent document. Even though great care has been taken in compiling the references, errors or omissions cannot be excluded and the EPO disclaims all liability in this regard.*

**Patent documents cited in the description**

- US 20140345060 A1 [0002]

专利名称(译)	模块化转向辅助装置及其方法		
公开(公告)号	<a href="#">EP3476380B1</a>	公开(公告)日	2020-05-13
申请号	EP2018200545	申请日	2018-10-15
[标]申请(专利权)人(译)	希尔 - 罗姆服务股份有限公司		
申请(专利权)人(译)	HILL-ROM SERVICES , INC.		
当前申请(专利权)人(译)	HILL-ROM SERVICES , INC.		
[标]发明人	RIBBLE DAVID LANCE EMMONS KIRSTEN M MEYERSON CRAIG M HEIL THOMAS F		
发明人	RIBBLE, DAVID LANCE EMMONS, KIRSTEN M. MEYERSON, CRAIG M. HEIL, THOMAS F		
IPC分类号	A61G7/00 A61G7/057 A61G7/008 A61G7/015 A61B5/00		
CPC分类号	A61B5/024 A61B5/0402 A61B5/0816 A61B5/4809 A61B5/4818 A61B5/6892 A61B2562/0219 A61G7/001 A61G7/008 A61G7/015 A61G7/05776 A47C27/08 A47G2009/003 A61B5/0205 A61B5/0476 A61B5/11 A61B5/4815 A61G7/057 A61M2230/10 G08B21/06		
优先权	62/576275 2017-10-24 US		
其他公开文献	EP3476380A1		
外部链接	<a href="#">Espacenet</a>		

摘要(译)

治疗支撑设备包括沿纵轴延伸的用户支撑表面。使用者支撑表面具有头部和躯干部分。头部和躯干部分中的每一个都可相对于纵向轴线成角度地操作。升降单元可操作以将头部和躯干部分中的至少一个相对于纵向轴线以一定角度定位。监视器在用户支撑表面上睡觉时获取与用户有关的数据。警报器可操作以基于监视器获取的数据来激活。

