

(19)



(11)

EP 2 911 578 B1

(12)

EUROPEAN PATENT SPECIFICATION

(45) Date of publication and mention of the grant of the patent:
25.12.2019 Bulletin 2019/52

(51) Int Cl.:
A61B 5/00 (2006.01) A61B 5/0478 (2006.01)
A61B 5/04 (2006.01)

(21) Application number: **13849498.4**

(86) International application number:
PCT/US2013/066661

(22) Date of filing: **24.10.2013**

(87) International publication number:
WO 2014/066666 (01.05.2014 Gazette 2014/18)

(54) SYSTEMS FOR DETECTING BRAIN-BASED BIO-SIGNALS

SYSTEME ZUM NACHWEIS GEHIRNFUNDIERTER BIOSIGNALE

SYSTÈMES POUR DÉTECTER DES SIGNAUX BIOLOGIQUES BASES SUR LE CERVEAU

(84) Designated Contracting States:
AL AT BE BG CH CY CZ DE DK EE ES FI FR GB GR HR HU IE IS IT LI LT LU LV MC MK MT NL NO PL PT RO RS SE SI SK SM TR

• **KIMANI MWANGI, Anthony, P.**
Faiburn, GA 30213 (US)

(30) Priority: **24.10.2012 US 201261717997 P**
15.03.2013 US 201361790007 P

(74) Representative: **Raffay & Fleck**
Patentanwälte
Grosse Bleichen 8
20354 Hamburg (DE)

(43) Date of publication of application:
02.09.2015 Bulletin 2015/36

(56) References cited:
WO-A1-2006/072150 WO-A2-2009/137520
WO-A2-2012/027648 US-A1- 2001 025 146
US-A1- 2007 032 737 US-A1- 2007 106 172
US-A1- 2008 208 073 US-A1- 2009 082 829
US-A1- 2009 083 071 US-A1- 2012 041 330
US-A1- 2012 330 178 US-A1- 2013 184 316
US-A1- 2013 211 270 US-B2- 8 150 523
US-B2- 8 190 248

(73) Proprietor: **Dreamscape Medical LLC**
Atlanta, Georgia 30308 (US)

(72) Inventors:
• **WALKER, Elijah, Charles**
Silver Spring, MD 20905 (US)

EP 2 911 578 B1

Note: Within nine months of the publication of the mention of the grant of the European patent in the European Patent Bulletin, any person may give notice to the European Patent Office of opposition to that patent, in accordance with the Implementing Regulations. Notice of opposition shall not be deemed to have been filed until the opposition fee has been paid. (Art. 99(1) European Patent Convention).

DescriptionCross Reference to Related Applications

[0001] The present application claims the benefit of priority of U.S. Provisional Application No. 61/717,907 filed October 24, 2012, and of U.S. Provisional Application No. 61/790,007.

Field of the Invention

[0002] The present invention relates to a system for detecting a multicomponent brain-based electromagnetic bio-signal. Also disclosed is a method for detecting, processing and extracting a variety of biasignals from a brain-based multi-component signal detected in the oral cavity.

Background of the Invention

[0003] Using electroencephalogram ("EEG") sensors positioned on the scalp to detect brain activity has been known in the art since the 1920's. As the electrical field generated by brain activity is very small, it can only be recognized by EEG if large assemblies of neurons show a similar behavior. The resulting neural EEG signals are in the range of micro-volts (μV) and may be easily be masked by interfering artificial sources causing artifacts in the signal. Typically, artifacts in an EEG signal are caused either by the non-neural physiological activities of the subject or by external technical sources. Non-neural physiological activities may include eye blinks, eye movements, muscle activity in the vicinity of the head (e.g. face muscles, jaws, tongue, neck), heartbeat, pulse and Mayer waves, and the like. External technical sources may include swaying cables in the magnetic field of the earth, improper grounding, power supplies or transformers, radio waves and the like.

[0004] Other ways to monitor brain electrical activity rely on invasive procedures including needle electrodes (sharp wires placed between the scalp and the skull); cortical electrodes, subdural electrodes and depth electrodes. The characteristics of brain electrical activity monitored with invasive electrodes are related to surface electrodes like EEG electrodes on the scalp or skin, but are different since attenuation and spreading of the signal by the scalp and skin is bypassed.

[0005] WO 2012/027648 discloses an intraoral multi-sensor device including a mouthpiece, a plurality of sensors, e.g. EEG sensors, at least one of the sensors attached to or integrated with the mouthpiece, and a data communications unit configured to receive signals from the plurality of sensors. The mouthpiece has a form to permit stable arrangement at least partially within a person's mouth such that it can remain for hands-free sensing of a plurality of biological parameters.

[0006] Thus it is desirable to detect and monitor brain activity and brain-based bio-signals with little interfer-

ence from other electrical sources and without requiring invasive procedures.

[0007] The description herein of certain advantages and disadvantages of known methods and devices is not intended to limit the scope of the present invention. Indeed, the present embodiments may include some or all of the features described above without suffering from the same disadvantages.

10 Summary of the invention

[0008] The present invention provides a system for detecting a multicomponent brain-based electromagnetic bio-signal as defined in claim 1.

15 **[0009]** In view of the foregoing, it is a feature of the embodiments described herein to provide a system for monitoring electromagnetic activity in the brain via the oral cavity without using invasive procedures. Particular brain-based electromagnetic bio-signals can include multiple component signals forming a multicomponent brain-based signal, that may include signals that are generated from other parts of the body including the central nervous system, heart electrical activity, lung activity (respiration), local artery movement, eye dipole electrical activity (and other dipoles), muscle electrical activity, and local tissue electrical activity such as generated by the peripheral nervous system, as well as brain-based electromagnetic signals. The multicomponent brain-based signal is detected by sensors positioned in the oral cavity. The multicomponent brain-based signal may then digitized, amplified and filtered. After filtering desired sub-component bio signals are isolated from the multicomponent brain-based signal for further analysis.

20 25 30 35 40 45 **[0010]** For the purposes of this invention, "multicomponent brain-based signal" is used to describe this collection of sub-component bio-signals, as the primary component bio-signals of interest emanates from the brain. The multicomponent brain-based signal can include bio-electromagnetic signals, cardiac bio-electromagnetic bio-signals, local tissue bio-electromagnetic signals; eye dipole bioelectric bio-signals; muscle bio-electromagnetic bio-signals; tongue bio-electromagnetic bio-signals; cardiac related pulsatile bio-signals; respiration related pulsatile bio-signals; movement related bio-signals; biomechanical bio-signals; bio-acoustic bio-signals. The component signals of the multicomponent brain-based signal are important for many applications (e.g. medical, veterinary and non-medical applications). Due to the brain-based signal detector(s) of this invention being located in the oral cavity, the detector(s) may detect electrical activity from many parts of the brain that includes the cerebral cortex, as well as other parts of the brain.

55 Brief Description of the Drawings

[0011]

Figure 1 is a comparative schematic view of hard palate multicomponent brain-based bio-signal detection versus scalp EEG brain wave detection.

Figure 2 is a schematic view of the hard palate multicomponent brain-based bio-signal and the resulting subcomponent waves after extraction.

Figure 3 is a comparative schematic view of an extracted hard palate alpha wave subcomponent signal versus scalp EEG alpha waves.

Figure 4 is an overlay schematic view of an extracted hard palate brain-based bio-signal subcomponent signal versus scalp EEG brain waves during mental counting activity.

Figure 5 is a comparative schematic view of an extracted hard palate brain-based bio-signal subcomponent signal versus raw EOG brain waves during up-down eye movement.

Figure 6 is a comparative schematic view of an extracted hard palate brain-based bio-signal subcomponent signal versus raw EOG brain waves during left-right eye movement.

Figure 7 is a comparative schematic view of an extracted hard palate brain-based bio-signal subcomponent signal versus cardiac ECG waves.

Figure 8 is a comparative schematic view of an extracted hard palate brain-based bio-signal subcomponent signal versus EEG, EOG and Respiration waves.

Figure 9 is schematic views of various embodiments of the electrodes of the invention.

Figure 10 is a schematic view a system to detect sleep disorders including internal and external units.

Figure 11 is schematic view of an alternative embodiment multi-sensor system.

Figure 12 is an isometric view of an embodiment of an oral attachment device.

Figure 13 is an isometric view of an embodiment of an oral attachment device.

Figure 14 is an isometric view of an embodiment of an oral attachment device.

Figure 15 is a sagittal view of a human head with the oral attachment device of **Figure 12** inserted in the oral cavity.

Detailed Description of the Invention

[0012] The following description is intended to convey a thorough understanding of the embodiments by providing a number of specific embodiments and details involving methods for detecting and processing brain-based multi-component signals in an oral cavity. It is understood, however, that the invention is not limited to these specific embodiments and details, which are exemplary only. It is further understood that one possessing ordinary skill in the art, in light of known devices, systems and methods, would appreciate the use of the invention for its intended purposes and benefits in any number of alternative embodiments.

[0013] In a preferred embodiment of the invention a system for detecting multi-component brain-based electromagnetic bio-signals includes a sensor in the oral cavity may be coupled to one or more electronic processors capable of electronically digitizing, amplifying, attenuating, filtering and normalizing the multi-component brain-based bio-signals as needed. The computer processor may also be capable of extracting, isolating or otherwise dividing sub-component signals from the multi-component brain-based bio-signals, and optionally classifying and analyzing the subcomponent signals.

[0014] The sensor may be an electrical or magnetic sensor capable of detecting multi-component brain-based electromagnetic bio-signals. In a preferred embodiment the sensor includes electrodes touching the hard palate, where one electrode acts as a reference for comparison with one or more other electrodes.

[0015] The electrodes may be resistive mode electrodes, capacitive mode electrodes, current mode electrodes, or inductive mode electrodes. The electrodes may be passive electrodes which simply receive a signal, or may be active electrodes which are able to digitize or otherwise process the received signal with an internal electronic processor.

[0016] In some embodiments the sensor in the oral cavity may be included in an oral device configured to couple to the dentition or other oral tissue. In further embodiments the position of the sensor or electrodes of the sensor may be adjustable in relation to the oral device.

[0017] In some embodiments the sensor may be communicatively coupled to a processor in the oral device. In other embodiments the sensor may be communicatively coupled to one or more external processing device. The sensor and/or processor(s) may be communicatively coupled via wires and/or wirelessly, such as Bluetooth or other wireless technology,

[0018] **Figure 1** is a comparison of the hard palate 10 multicomponent brain-based bio-signal 100 versus a standard scalp EEG brain wave signal. A sensor including reference electrode 11 and left signal electrode 12 coupled or proximate to hard-palate 10 are used to detect the multicomponent brain-based bio-signal 100. In some embodiments the sensor may also include right signal electrode 13. The multicomponent brain-based bio-sig-

nal **100** is the raw hard palate bio-potential signal. The raw unfiltered scalp EEG signal **200** is detected from the F4A2 electrode **20** (F=frontal, 4=right side of scalp by 10-20 standards) with a reference electrode on the right mastoid. The multicomponent brain-based bio-signal **100** is a relatively unremarkable pattern of the raw hard palate bio-potential signal in comparison to the raw scalp EEG signal **200**. The multicomponent brain-based bio-signal **100** has a significantly larger voltage range when compared to raw scalp EEG signal **200**, 100 μV versus 10 μV respectively. This demonstrates that special analysis of the hard palate **10** multicomponent brain-based bio-signal **100** is necessary to determine subcomponents of the hard palate **10** multicomponent brain-based bio-signal **100** especially the brain-based subcomponent signals.

[0019] The reference electrode **11** was placed on the hard palate **10** to avoid mixing of scalp EEG with, oral brain-based signals. left signal electrode **12** and right signal electrode **13** may be gold or gold plated electrodes covered in cotton gauze. Saline may be used in some embodiments to wet the gauze.

[0020] **Figure 2** shows the hard palate **10** multicomponent brain-based bio-signal **100** being split into its various subcomponent signals after being processed according to embodiments of this invention. The subcomponent signals may include an 8 - 14 Hz brain wave subcomponent signal **101**, an eye movement subcomponent signal **103**, a cardiac subcomponent signal **104** and a respiration subcomponent signal **105**.

[0021] **Figure 3** shows the strong correlation between the 8 - 14 Hz brain wave subcomponent signal **102** detected on the hard palate and the 8 - 14 Hz brain wave scalp EEG signal **201**.

[0022] **Figure 4** shows the strong correlation between the 3.5 - 30 Hz brain wave subcomponent signal **102** detected on the hard palate and the 3.5 - 30 Hz brain wave scalp EEG signal **202** of a subject when subject was performing the mental activity of counting backwards from 100 by 7's (i.e. 100, 93, 86, 79, etc.). The subject was seated in a well-lit, environmentally controlled room.

[0023] **Figure 5** shows the strong correlation between an 80 μV range multicomponent brain-based bio-signal **100** detected on the hard palate **10** and the 53 μV brain wave EOG signal **300** detected with EOG electrodes **30** on the right-side human scalp while the subject was quickly looking up and down. No filtering or isolation of subcomponents of the multicomponent brain-based bio-signal **100** was needed for this embodiment.

[0024] **Figure 6** shows the correlation between an 50 μV range multicomponent brain-based bio-signal **100** detected on the hard palate **10** and the 558 μV brain wave EOG signal **300** detected with EOG electrodes **30** on the right-side human scalp while the subject was quickly looking left and right. No filtering or isolation of subcomponents of the multicomponent brain-based bio-signal **100** was needed for this embodiment.

[0025] **Figure 7** shows the correlation between cardiac

signals detected at 0.5 - 249 Hz in the brain wave subcomponent signal **104** on the hard palate **10** and the cardiac signals in an unfiltered ECG signal **400** detected with ECG electrode **40**. The subject was seated in a well-lit, environmentally controlled room during recording. The multicomponent brain-based bio-signal **100** was filtered this application to remove DC offset.

[0026] **Figure 8** shows the correlation between respiration sub component signals **106** at 1.5 Hz - 249 Hz extracted from the brain-based multicomponent bio-signals detected on the hard palate **10** and scalp EEG signals **203**, right eye EOG signals **301** both of which were filtered at 1.5 Hz - 249 Hz, and a nasal cannula respiration signal **500** while the subject takes a fast deep breath **501** and holds the breath **502** for 20 seconds. The graph shows that the hard palate bio-potential changes at the same time the scalp EEG and EOG changes showing the strong temporal relation between the hard palate multicomponent bio-signals and the scalp related signals.

[0027] **Figure 9** shows various electrode embodiments for use in hard palate multicomponent bio-signal detection to accommodate the shape of oral tissue and provide for comfort and biocompatibility. Soft materials (gauze, or foam) may provide mechanical safety and maintains electrolytes around the electrode. Other materials can be used for electrodes as desired. The electrode assembly **50** include a metal electrode **51** and temperature sensor **52**. The combination of electrode **51** with temperature sensing **52** for the oral cavity or other body locations. The electrodes detect current flow from tissue and the temperature sensor allows determination of oral temperature, motion artifact (since temperature is not a bio-potential measurement), and oral airflow. Average oral temperature can be estimated by a thermistor, semiconductor IC, thermocouple, or other appropriate sensor. Variations in temperature arising from airflow can be used to determine the presence/absence of airflow as part of pre-processing or by the microcontroller (μCU). One embodiment of the electrode may be a convex electrode assembly **60** which may include a metal electrode with a lead wire **61** and temperature sensor **62** and a soft, absorbent cover-surface **63**. Another embodiment of the electrode may be a concave electrode assembly **70** which may include a metal electrode with a lead wire **71** and temperature sensor **72** and a soft, absorbent cover-surface **73**. A third embodiment of the electrode may be a flat electrode assembly **80** which may include a metal electrode with a lead wire **81** and a soft, absorbent cover **82**. The reference electrode **11**, may be a circular metal electrode.

[0028] **Figure 10** is a schematic of a system to detect sleep disorders **600** including an internal oral unit **601** and an external unit **650**. The internal oral unit **601** may include a convex electrode **60** positioned near the middle of the hard palate and one or two concave electrodes **70** positioned to the left and/or right near the gums.

[0029] The internal oral unit **601** may include a sensor unit **602**, a power source **603**, a power manager **604**, a

microcontroller **605**, and a transmission unit **606**. The internal oral unit **601** may amplify, filter and/or digitize multicomponent bio-signals using dedicated circuitry as shown or as part of the data-management microcontroller (μ CU) Digital signals may be passed to a radiofrequency (RF) module for transmission to a remote receiver, e.g., a Smartphone or computer, or cloud etc.

[0030] Detecting multicomponent brain-based signals may be accomplished by placing the internal unit **601** inside the appropriate body cavity where brain-based multicomponent bio-signal detection can automatically (or manually) be initiated. Signal detection usually begins immediately, however a temperature sensing component can be added to monitor environmental temperatures to ensure proper operating conditions and or monitor temperature during data collection. The temperature sensor can also be used to monitor changes in airflow via the mouth. Additional sensors can also be added to monitor a variety of additional physiological variables including oxygen saturation via optical PPG sensor/monitor, accelerometer, gyroscope, GPS, pressure, camera, biological or chemical monitors etc. Brain-based Detectors monitor multiparameter physiological signals including brain waves.

[0031] The detector (i.e. sensor) can be based on any of the following sensors: resistance mode electrodes, capacitive mode electrodes, current mode electrodes, passive electrodes, active electrodes, magnetic mode detectors, inductive mode detectors, acoustic mode detectors, optical or electro-optic mode detectors, chemical or biochemical mode detectors, biological mode detectors and brain-based detector arrays (brain-based detector can also comprise multiple sensors oriented in different geometric planes). The sensors may be of various shapes and include various metals, metal salts, or metal alloys, semiconductors, polymers, carbon compounds, conductive fabrics, composites, graphenes, non-metals; sensor comprises rigid, semi-rigid, and other flexible materials. The sensors may utilize microelectronics technology. The sensors may be disposable and/or reusable. The sensors may include remote sensors. Sensors may be adjustable in position and/or performance to optimize brain-based multicomponent bio-signal detection.

[0032] Sensor unit **602** may detect electrical signals from the hard palate picked up by electrodes and may amplify and filter the electrical signals to remove motion and other artifacts and conveyed to the microcontroller (μ CU) **605** via the SPI bus for further processing, storage and transmission.

[0033] Signal and power management scheduling are performed by the μ CU **605**. Energy consumed from a disposable or rechargeable power supply **603** can be minimized by the μ CU **605** by controlling the duration and duty cycle of data-collection devices, the transmission module **606**, and the μ CU **605** itself. Intelligent power management can reduce the size and complexity of the power source **603** and eliminate the need for a power line-operated system.

[0034] Data transmission by the transmission unit **606** may be via well-known standard communications protocols, such as Bluetooth (BT) and Bluetooth LE (Low Energy) (BLE), or a proprietary protocols or frequencies. Use of standard protocols may ensure easier post-transmission processing. The transmission unit **606** may support both BT and BLE, which can be accessed by Smartphones and other devices. An antenna of the transmission unit **606** may be built into the side and/or front walls of an oral appliance attachment device as shown in **Figures 12-15**.

[0035] The external unit **650** includes a receiver unit **651**, a preprocessing unit **652**, an Independent Component Analysis ("ICA") processor **700**, a raw brain-based multicomponent bio-signal component analyzer **750**,

[0036] The receiver unit **651** may be configured to receive signals from the transmission unit **606**. The preprocessing unit **652** removes as much signal noise as possible The ICA processor **700** may use standard ICA algorithms to extract and isolate individual subcomponent signals. To ensure a good estimate of the components of the brain-based raw hard palate signal, brain wave filters 1-N **751**, **752** and **753**, eye movement signal processor **710**, cardiac signal processor **720** and respiration signal processor **730**.

[0037] To ensure a good estimate of the subcomponents of the brain-based raw hard palate multicomponent bio-signal it's important to remove as much signal noise as possible with a preprocessing unit **652**. The preprocessing unit **652** may eliminate non-physiological noise via filtering and sensors (thermistors) built into electrodes or a sensor platform. Electrodes may be shielded on their rear surface by the oral attachment device to prevent disturbance by the tongue and or internal facial muscles. Thermistors also, provide a means to detect movement of the device relative to tissue as well as provide means to correct for large temperature changes due to breathing. Additional processing includes data filtering such as low pass filtering. Additional preprocessing may include centering and whitening. Centering removes the mean from each component by subtracting the mean of the data from the actual data. Whitening the data is done to make the raw data uncorrelated to ensure that each subcomponent is as independent as possible. Preprocessing can also identify eye movements due to the unique arrangement of the electrodes (left and right) that produce significant differences in the raw signal detected by each electrode. Root mean square values can be determined and threshold detectors may be incorporated.

[0038] Digitization by the pre-processing unit **652** may be electronically performed to enable efficient digital processing as well as signal amplification and or attenuation of the bio-signals if necessary. Pre-processing also seeks to remove unwanted noise by filtering, shielding, blocking, or algorithmically removing or eliminating undesirable physiological and or non-physiological signals such as electrical noise, acoustical noise, mechanical noise, other artifact, or galvanic currents from dis-

similar metals, or tongue artifact etc. Undesirable artifact contained in biosignals can hamper recordings. Signal normalization can also occur at this stage.

[0039] The ICA processor **700** determines, the individual subcomponent signals of the raw hard palate multi-component bio-signal without previously knowing each component. To effectively determine each subcomponent the number of detectors (sensors) must be equal to or greater to the number of individual signal components. Embodiments may utilize three electrodes to detect bio-potentials each with a built-in thermistor which provides six (6) detectors overall. This embodiment may detect 4 subcomponent bio-signals. To separate the components the JADE algorithm (Joint Approximate Diagonalization Eignen Matrices), which tends to perform best for small datasets) can be incorporated used by the ICA processor **700** of a computer or Field Programmable Gate Array (FPGA).

[0040] Extracting, isolating, or dividing the detected multicomponent brain-based signal into individual par-subcomponent signals may involve appropriate means to extract, isolate, and/or divide the brain-based multicomponent signal into constituent physiological signals and/or other signals as desired.

[0041] Primary subcomponent signals may include brain-based bio-electromagnetic signals, cardiac bio-electromagnetic bio-signals, ECG, local tissue bio-electromagnetic signals; eye dipole bioelectric bio-signals, muscle bio-electromagnetic bio-signals, tongue bio-electromagnetic bio-signals, cardiovascular related pulsatile bio-signals (e.g. Blood Volume Pulse); respiration related pulsatile bio-signals, movement related bio-signals, bio-mechanical bio-signals and/or bio-acoustic bio-signals. Each subcomponent signal typically includes multiple frequencies, and may have different dynamic ranges that may overlap. In some embodiments additional physiological parameters can be derived, including heart rate, respiration rate, heart rate variability, pulse transit time, arterial blood pressure.

[0042] A variety of signal processing or signal analysis means (implemented in algorithms) can be utilized to extract the subcomponent bio-signals described. Subcomponent bio-signal extraction may include use of pattern recognition, Independent Component Analysis, Principle Component analysis, Linear analysis, Frequency domain analysis, time - frequency and nonlinear techniques such as correlation dimension (CD), phase space plots, different entropies, wavelet based, Hilbert-Huang Transforms (HHT), and similar means as desired.

[0043] For some applications, signal isolation or extraction may not be required. For example, eye movement signals tend to be larger than other oral signals so for eye movement applications extracting other signals may not be required.

[0044] In some embodiments key subcomponent signal features, such as data points, thresholds and/or data slope be extracted or isolated from the signal of interest. This may involve identification of brain-based signal pat-

terns and translation into commands to extract said feature and or issue commands to perform a task. A desired algorithm may be used to automatically estimate/calculate a value to represent the signals by a few relevant key values. There are a large variety of algorithms that may be implemented from the simplistic methods such as adding, subtracting, multiplying, dividing, etc., to other complex techniques involving time-based approaches or frequency based approaches, Principle component analysis, Support vector machine, Genetic algorithm, Distinctive sensitive learning vector quantization etc.

[0045] In some embodiments key features of a subcomponent bio-signal may be classified or translated to a command. The classification step assigns a class to a set of features extracted from the signals. The class can correspond to the type of mental states identified. This step can also be denoted as "feature translation".

[0046] Key feature information may be provided or displayed to a user/operator and/or used to perform tasks, such as comparing an extracted subcomponent bio-signals to a database of baseline signals to control a device, assist in a diagnosis of a disease, disorder, or condition, and or report the status of the device function.

[0047] Following subcomponent bio-signal extraction, individual subcomponent bio-signals can be displayed or utilized for other purposes such as calculating vital signs, part of a command to control another device(s), or to perform additional processing such as extract particular features.

[0048] Following separation into individual subcomponent signals the raw brain- signal can be further analyzed or separated into various frequency bands using band-pass filters **750** and then displayed or used to issue a command. This may include brain wave filters 1-N **751**. The filters may be programmed or maintained in hardware for bands of interest **751, 753**.

[0049] Eye movement sub component signals **710** can be displayed and observed for Rapid Eye Movement (REM) to determine sleep stage.

[0050] Cardiac signals **720** can show basic heart rate and can be used to determine R wave peaks as well as heart rate variability.

[0051] Respiration signals **730** can be displayed to determine breathing rate.

[0052] Various data may be stored on a data storage device incorporated into the internal oral unit and/or external unit.

[0053] In some embodiments of the system may also include a stimulate tissue device.

[0054] In some applications brain-based biosignal maps can be developed to allow for topographical mapping of electrical activity for internal body locations.

[0055] An alternative embodiment that incorporates multiple sensors such as oxygen saturation, head position via accelerometers, temperature, and brain-based signals is shown in **Figure 11**.

[0056] **Figure 12** shows an embodiment of the internal oral unit **800** including convex electrodes **60** configured

to contact the center of the hard palate, and concave electrodes **70** configured to contact the gums. The internal oral unit **800** may be a mouth-guard platform which may incorporate a biocompatible adhesive to maintain contact with the dentition and/or oral tissue similar to a denture adhesive. In some embodiments the internal oral unit **800** electronic circuits **601** that perform some or all of the functions described above. The electrodes may be positioned in the structure which provides a slight spring force against the gums and hard palate to ensure electrode contact with oral tissue.

[0057] Figure 13 shows Oral attachment device **900**, which incorporates a flexible transverse support band **901** to maintain contact with the hard palate and electrodes **11, 12, 13** and temperature sensor **52**. Oral attachment device **900** may include electronics **601** and transmission unit **606**.

[0058] Figure 14 shows an oral attachment device **1000** which includes a thin flexible platform that incorporates a biocompatible adhesive to maintain contact with the mandible and flexible electronic circuits. The electrodes **11, 12** and **13** are positioned in the structure which provides a slight spring force against the gums and hard palate to ensure electrode contact with oral tissue. Some embodiments may include temperature **52**, electronics **601** and transmission unit **606**.

[0059] Figure 15 shows a sagittal view of a human head with an example of an oral attachment mouthguard **800** with electrodes contacting the the left and right side of the hard palate, and one electrode contacting the hard palate and transmission system, and an exemplary embodiment of the external unit **650**. External unit can be a smartphone, computer or other computing device.

[0060] An embodiment of the present invention may utilize subcomponent signals of the brain-based multicomponent bio-signals for screening, diagnosing and monitoring obstructive sleep apnea ("OSA"), OSA is a breathing disorder caused by movement and upper airway blockage by the tongue and narrowing of the upper airway by soft tissues within the nose, mouth and throat that occurs during sleep. This phenomenon causes snoring and recurrent interruption of breathing due to periodic obstruction of airflow in the upper airway during inhalation.

[0061] The current -state of the art in diagnosing OSA and other sleep disorders involves using multichannel polysomnography to evaluate EEG, respiratory signals, cardiac signals, muscle tone, eye movements, and leg movements of a sleeping patient. This requires the cumbersome attachment of multiple EEG leads to the scalp, as well other transducers such as microphones, electrocardiograph ("ECG") electrodes, electromyograph ("EMG") electrodes and a pulse oximeter attached various parts of a patient. Devices intended for home use may measure fewer parameters are available, but still require multiple connections.

[0062] Embodiments of the invention enable detection of multicomponent brain-based bio- signals (FIG. 2) from

which subcomponent bio- signals can be extracted including brain-based electrical activity including alpha or other waves (FIG. 3), eye movement (FIG. 5), respiration (FIG. 8) and ECG (FIG. 7). Brain electrical activity subcomponent signals can enable determination of sleep state/stage and overall sleep time. Respiration subcomponent bio-signals may enable determination of apnea events. Eye movement subcomponent bio-signals can enable determination of rapid eye movement (REM) sleep, and ECG subcomponent bio-signals can enable determination of heart rate during sleep. By analyzing the individual or combinations of these subcomponent bio-signals, either manually or with a computer system/program, a patients sleep pattern may be determined to diagnose OSA.

[0063] in some embodiments, signal processing (including filtering, amplification, digitizing, storage etc.) and recording of some or all of the sub-component signals may occur in computer chip(s) embedded in an oral device including the sensor(s) can be accomplished. Resulting data can either be transmitted as it becomes available via wired or wireless technology (such as Bluetooth) to a receiving device (such as a smartphone, a computer, or dedicated device) and/or uploaded to a receiving device at a later time.

[0064] In other embodiments the multicomponent brain-based bio-signal is transmitted to an external receiving device (such as a smartphone, a computer, or dedicated device) for signal processing. The multicomponent brain-based bio-signal may be transmitted as it is being detected by the sensor or it may be recorded on a storage device in an oral device for retrieval at a later time.

[0065] If desired, in further embodiments the sensor detecting the multicomponent brain-based bio-signal may be supplemented with additional secondary sensors (i.e. accelerometers, thermocouples, O₂ saturation sensors, CO₂ sensors, air flow meters, etc.) may be used in combination with the multicomponent brain-based bio-signal to determine head position and oxygen desaturation and other events during sleep.

[0066] In some embodiments, the oral device may automatically turn off when it is removed from the patient's mouth. In other embodiments the oral device may be turned off manually. The signals stored on the device may then be uploaded to a computer system including a software program for interpretation of the signal data, and be available for a diagnosis to be made by a physician or other medical personnel.

[0067] In some embodiments, the electrical brain activity subcomponent signals extracted from the detected brain-based multi-component signal may be used along with signals from accelerometers to detect traumatic brain injury in military personnel, sports participants, or other people in at-risk professions or activities, such as concussions, strokes and seizures. Detection of traumatic brain injury may be facilitated by comparing current subcomponent signals to pre-existing baseline signals. The

pre-existing baseline signals may be recorded from the specific patient being tested or a generic baseline derived from consolidation of multiple previously recorded signals from the patient or a segment of the population. In other embodiments these signals may be used to monitor performance.

[0068] In some embodiments, subcomponent signals extracted from the detected brain-based multi-component signal may be used to optimize training and provide feedback on performance of athletes and soldiers in order to enhance their capabilities during competition or in the field. The subcomponent signals extracted from the detected brain-based, multi-component signal may also be used in biofeedback applications.

[0069] In another embodiment, brain waves and muscle activity subcomponent signals extracted from the detected brain-based multi-component signal may be used to determine the level of consciousness of a patient under general anesthesia.

[0070] In another embodiment, subcomponent signals extracted from the detected brain-based multi-component signal may be used to detect abnormal brain wave patterns indicative of hypoglycemia in persons with diabetes.

[0071] In another embodiment, brain-based bio-signals, eye movement, head position and breathing signals and other subcomponent signals extracted from the detected brain-based multi-component signal may be used to assist individuals who are physically impaired but mentally capable to operate a wide variety of equipment and tools using a brain-computer interface which interprets the subcomponent signals to operate a variety of equipment's actions. For example moving an motorized wheel chair or operating an artificial limb.

[0072] in another embodiment brain waves and eye movement subcomponent signals extracted from the detected brain-based multi-component signal can be monitored for advertising or media programming evaluation.

[0073] In another embodiment, a user can be trained to alter his brain waves in order to send a subcomponent signal extracted from the detected brain-based multi-component signal to a central computer in order to automatically control his mobile telephone, video game console, television set, music system or DVD player; change the temperature settings in the room; control an alarm system; control kitchen appliances; or control an automobile's computer system. For example, subcomponent signal extracted from the detected brain-based multi-component signal may be used to detect drowsiness or sedatives or drug related impairment in the operator of a motor vehicle by monitoring sub-component signals related to respiration, eye movement, and other useful parameters. The device for this application may be in the form of a nose clip, a mouthpiece, or combinations thereof that collects and processes brain-based multi-component signal via an onboard computer that can subsequently trigger alarm systems and provide notification, or alarm when a driver becomes a drowsy or falls asleep

at the wheel.

[0074] In another embodiment, a device may utilize subcomponent signal extracted from the detected brain-based multi-component signal, such as eye movement and other bio-signals to control machines such as automobiles or airplanes using thought control especially for complex, rapid or emergency maneuvers, For example one application may be enhancing combat or drone pilots reaction times and assist in the control of aircraft during high-performance or wartime situations.

[0075] In an alternative embodiment of the system, the sensor and/or other elements of the system may be implanted in soft tissue, such as the soft palate or gums; or alternatively inside teeth or tooth implants; or in a third alternative, in parts of the body other than the oral cavity. For example the sensor and/or other elements of the system can be implanted in the soft palate and self-powered via piezoelectric material within the device. Or in another example the sensor and/or other elements of the system may be implanted beneath the skin and periodically charged inductively, capacitively, optically or other charging methods.

[0076] In another alternative embodiment the sensor and/or other elements of the system may be located in a swimmer's or underwater diver's mouthpiece.

[0077] In third alternative embodiment, the sensor and/or other elements of the system may be mounted on a nose clip designed for comfortable placement within the nostrils of an individual.

[0078] Though many of the embodiments described herein describe applications in the oral cavity; the systems and methods described herein may also be applied to other internal tissues accessed through orifices or incisions in the body.

[0079] In the preceding specification, various preferred exemplary embodiments have been described with reference to the accompanying drawings. It will, however, be evident that various modifications and changes may be made thereto, and additional exemplary embodiments may be implemented, without departing from the broader scope of the invention as set forth in the claims that follow. The specification and drawings are accordingly to be regarded in an illustrative rather than restrictive sense.

Claims

1. A system for detecting a multicomponent brain-based electromagnetic bio-signal (100) comprising:

at least two bio-signal sensors (11, 12, 13, 52, 60, 70) forming part of an oral attachment device (800, 900, 1000) configured to be positioned in an oral cavity to bring into contact the at least two bio-signal sensors with an oral tissue (10), wherein said at least two bio-signal sensors have a wired or wireless connection to at least one external computer processing unit (650),

- the at least two bio-signal sensors configured to detect a raw oral multicomponent electromagnetic bio-signal at the oral tissue and send the raw oral multicomponent electromagnetic bio-signal to the at least one external computer processing unit (650) that includes an independent component analysis processor (700) that isolates at least one primary raw brain-based multicomponent electromagnetic bio-signal (100) from a plurality of other subcomponents (710, 720, 730) within the raw oral multicomponent electromagnetic bio-signal, and wherein said external computer processing unit (650) further includes a plurality of brain waves band pass filters (750) that are configured to further separate the raw brain-based multicomponent signal (100) into a plurality of frequency brain wave bands (751, 752).
2. The system of claim 1, further comprising a temperature sensor (52) attached to the oral attachment device (800, 900, 1000).
 3. The system of any of claims 1 or 2, wherein the oral attachment device (800, 900, 1000) is configured to engage teeth.
 4. The system of any of claims 1-3, wherein the oral attachment device (800, 900, 1000) includes concave electrodes (70) configured to contact the at least two bio-signal sensors to gums.
 5. The system of any of claims 1-3, wherein the oral attachment device (800, 900, 1000) includes convex electrodes (60) configured to contact the at least two bio-signal sensors to hard palate tissue.
 6. The system of any of claims 1-5, wherein the at least one raw brain-based multicomponent bio-signal (100) correlates with electroencephalogram (EEG) signal data.
 7. The system of any of claims 1-6, wherein the at least one computer processing unit (650) is configured to generate a command based on data from the wave band (751, 752) filtered from the at least one primary raw brain-based multicomponent electromagnetic bio-signal (100).
 8. The system of any of claims 1-7, wherein the at least one computer processing unit (650) is configured to generate a diagnosis of a condition in response to comparing data from the wave band (751, 752) filtered from the at least one primary raw brain-based multicomponent electromagnetic bio-signal (100) to predetermined baseline data for diagnosis of the condition.

9. The system of claim 8, wherein the condition is at least one of obstructive sleep apnea, concussion or seizure.

Patentansprüche

1. System zum Nachweis eines gehirnfundierten elektromagnetischen Biosignals (100), umfassend:
 - mindestens zwei Biosignalsensoren (11, 12, 12, 52, 60, 70), die einen Teil einer oralen Befestigungsvorrichtung (800, 900, 1000) ausbilden, dazu ausgelegt, in einem oralen Hohlraum positioniert zu sein, um die mindestens zwei Biosignalsensoren in Kontakt mit einem oralen Gewebe (10) zu bringen, wobei die mindestens zwei Biosignalsensoren eine kabelgebundene oder kabellose Verbindung mit mindestens einer externen Rechnerverarbeitungseinheit (650) aufweisen, wobei die mindestens zwei Biosignalsensoren dazu ausgelegt sind, ein rohes, orales, elektromagnetisches Mehrkomponentenbiosignal an dem oralen Gewebe nachzuweisen und das rohe, orale, elektromagnetische Mehrkomponentenbiosignal an die mindestens eine externe Rechnerverarbeitungseinheit (650) zu senden, die einen unabhängigen Komponentenanalyseprozessor (700) beinhaltet, der mindestens ein primäres, rohes, gehirnfundiertes, elektromagnetisches Mehrkomponentenbiosignal (100) von einer Vielzahl von anderen Subkomponenten (710, 720, 730) innerhalb des rohen, oralen, elektromagnetischen Mehrkomponentenbiosignals isoliert, und wobei die externe Rechnerverarbeitungseinheit (650) ferner eine Vielzahl von Gehirnwellenbandpassfiltern (750) beinhaltet, die dazu ausgelegt sind, das rohe, gehirnbasierte Mehrkomponentensignal (100) weiter in eine Vielzahl von Frequenzgehirnwellenbändern (751, 752) zu separieren.
2. System nach Anspruch 1, ferner umfassend einen Temperatursensor (52), angebracht an der oralen Anbringungs Vorrichtung (800, 900, 1000).
3. System nach einem der Ansprüche 1 oder 2, wobei die orale Anbringungs Vorrichtung (800, 900, 1000) dazu ausgelegt ist, in Zähne einzugreifen.
4. System nach einem der Ansprüche 1-3, wobei die orale Anbringungs Vorrichtung (800, 900, 1000) konkave Elektroden (70) beinhaltet, die dazu ausgelegt sind, die mindestens zwei Biosignalsensoren zu Zahnfleisch zu kontaktieren.
5. System nach einem der Ansprüche 1-3, wobei die

orale Anbringungs­vorrichtung (800, 900, 1000) konvexe Elektroden (60) beinhaltet, die dazu ausgelegt sind, die mindestens zwei Biosignalsensoren zu Hartgaumengewebe zu kontaktieren.

6. System nach einem der Ansprüche 1-5, wobei das mindestens eine rohe, gehirnbasierte Mehrkomponentenbiosignal (100) mit Elektroenzephalogramm-Signaldaten (EEG-Signaldaten) korreliert.
7. System nach einem der Ansprüche 1-6, wobei die mindestens eine Rechnerverarbeitungseinheit (650) dazu ausgelegt ist, einen Befehl, basierend auf Daten von dem Wellenband (751, 752), gefiltert aus dem mindestens einen primären, rohen, gehirnbasierten, elektromagnetischen Mehrkomponentenbiosignal (100), zu generieren.
8. System nach einem der Ansprüche 1-7, wobei die mindestens eine Rechnerverarbeitungseinheit (650) dazu ausgelegt ist, eine Diagnose einer Bedingung in Reaktion auf ein Vergleichen von Daten von dem Wellenband (751, 752), gefiltert aus dem mindestens einen primären, rohen, gehirnbasierten, elektromagnetischen Mehrkomponentenbiosignal (100), mit vorbestimmten Basisdaten zur Diagnose der Bedingung zu generieren.
9. System nach Anspruch 8, wobei die Bedingung mindestens eine von obstruktiver Schlafapnoe, Konkussion oder Iktus ist.

Revendications

1. Système de détection d'un signal biologique électromagnétique multicomposant fondés sur le cerveau (100) comprenant :
- au moins deux capteurs de signaux biologiques (11, 12, 13, 52, 60, 70) faisant partie d'un dispositif de fixation orale (800, 900, 1000) configuré pour être positionné dans une cavité orale pour mettre en contact lesdits au moins deux capteurs de signaux biologiques avec un tissu oral (10), dans lequel lesdits au moins deux capteurs de signal biologique ont une connexion câblée ou sans fil à au moins une unité de traitement informatique externe (650), lesdits au moins deux capteurs de signal biologique configurés pour détecter un signal biologique électromagnétique oral brut multicomposant au tissu oral et envoyer le signal biologique électromagnétique oral brut multicomposant au moins une unité de traitement informatique externe (650) qui inclut un processeur indépendant (700) pour l'analyse des composants qui isole au moins un signal

biologique électromagnétique primaire multicomposant (100) brut à partir de plusieurs autres sous composants (710, 720, 730) à l'intérieur du signal électromagnétique-biologique oral brut multicomposant, et dans lequel ladite unité de traitement informatique externe (650) comprend en outre une pluralité de filtres passe-bande d'ondes cérébrales (750) qui sont configurés pour séparer davantage le signal cérébral brut multicomposant (100) en une pluralité de bandes d'ondes cérébrales (751, 752) de fréquence.

2. Système selon la revendication 1, comprenant en outre un capteur de température (52) fixé au dispositif de fixation orale (800, 900, 1000).
3. Système selon l'une quelconque des revendications 1 ou 2, dans lequel le dispositif de fixation orale (800, 900, 1000) est configuré pour s'engager dans les dents.
4. Système selon l'une quelconque des revendications 1 à 3, dans lequel le dispositif de fixation orale (800, 900, 1000) comprend des électrodes concaves (70) configurées pour entrer en contact avec les gencives au moins deux capteurs de signaux biologiques.
5. Système selon l'une quelconque des revendications 1 à 3, dans lequel le dispositif de fixation orale (800, 900, 1000) comprend des électrodes convexes (60) configurées pour entrer en contact avec lesdits au moins deux capteurs de signal biologique pour toucher le tissu du palais dur.
6. Système selon l'une quelconque des revendications 1 à 5, dans lequel ledit au moins un signal biologique cérébral brut multicomposant (100) est en corrélation avec des données de signal électroencéphalogramme (EEG).
7. Système selon l'une quelconque des revendications 1 à 6, dans lequel ladite au moins une unité de traitement informatique (650) est configurée pour générer une commande fondée sur des données provenant de la bande d'ondes (751, 752) filtrée à partir du au moins un signal biologique électromagnétique primaire multicomposant (100) à partir du cerveau brut.
8. Système selon l'une quelconque des revendications 1 à 7, dans lequel ladite au moins une unité de traitement informatique (650) est configurée pour générer un diagnostic d'une condition en réponse à une comparaison de données de la bande d'ondes (751, 752) filtrées à partir du au moins un signal biologique électromagnétique primaire multicomposant fondés sur le cerveau brut (100) vers des données

de base prédéterminées pour le diagnostic de la condition.

9. Système selon la revendication 8, dans lequel l'état est au moins l'un des états suivants: apnée obstructive du sommeil, commotion cérébrale ou convulsion.

10

15

20

25

30

35

40

45

50

55

FIGURE 1

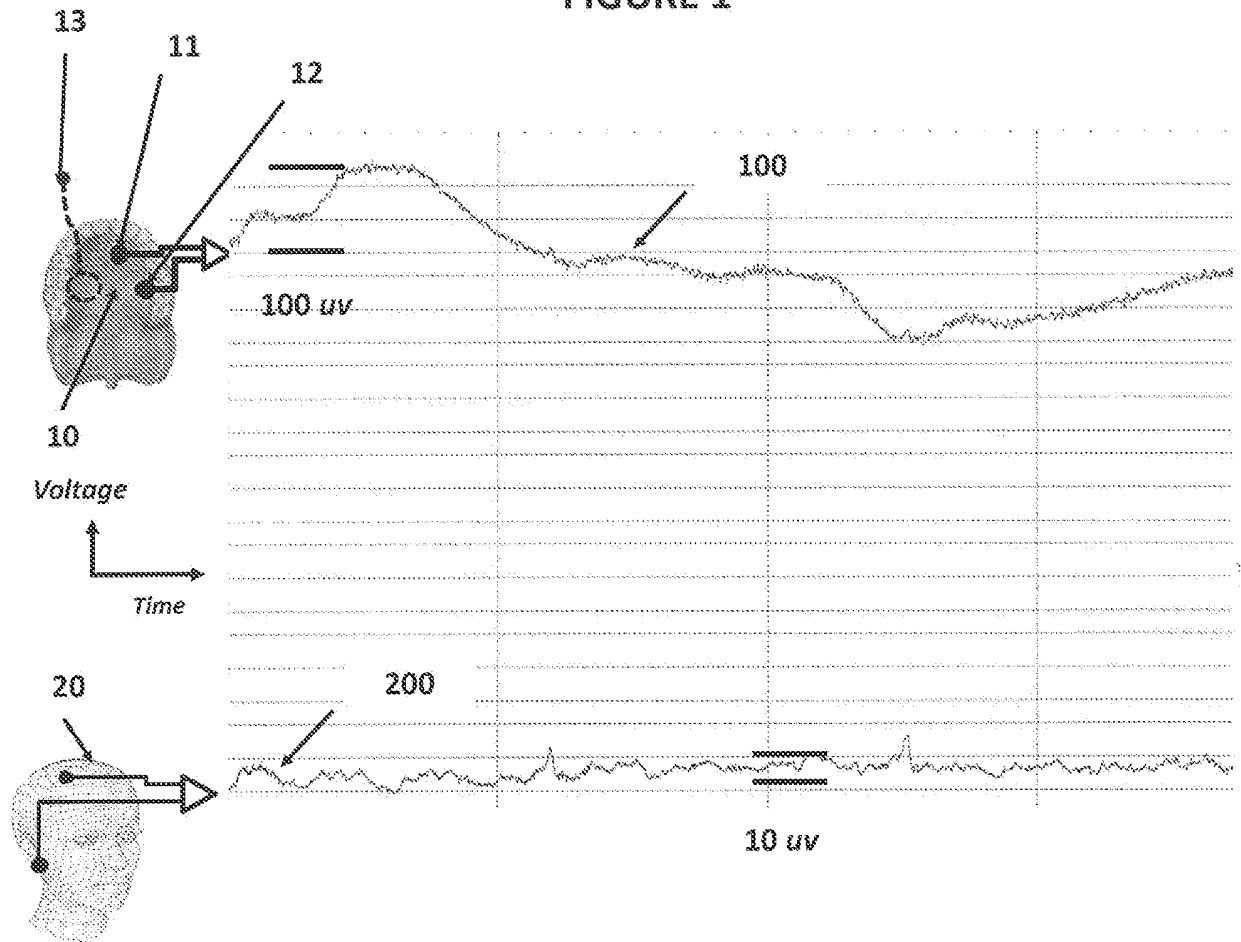

FIGURE 2

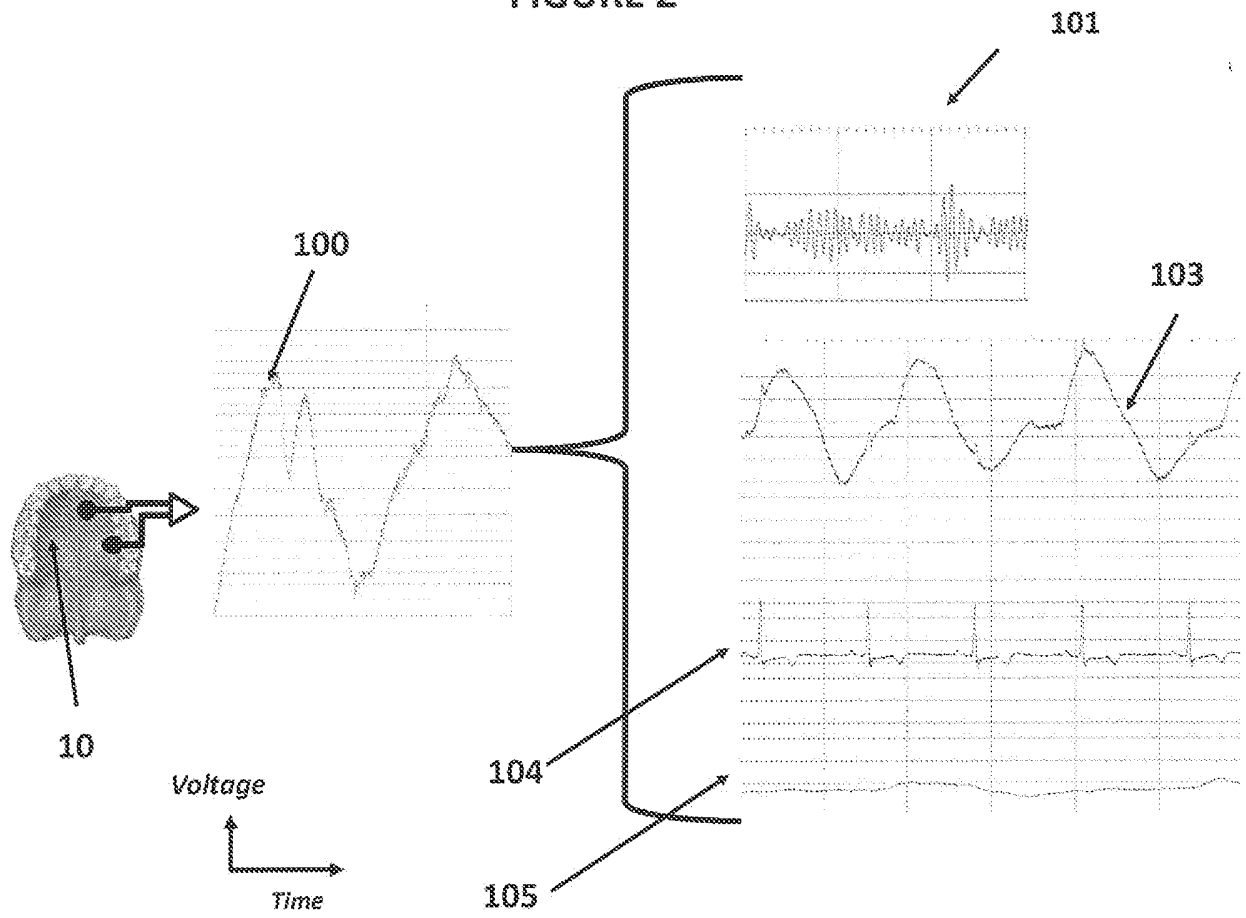

FIGURE 3

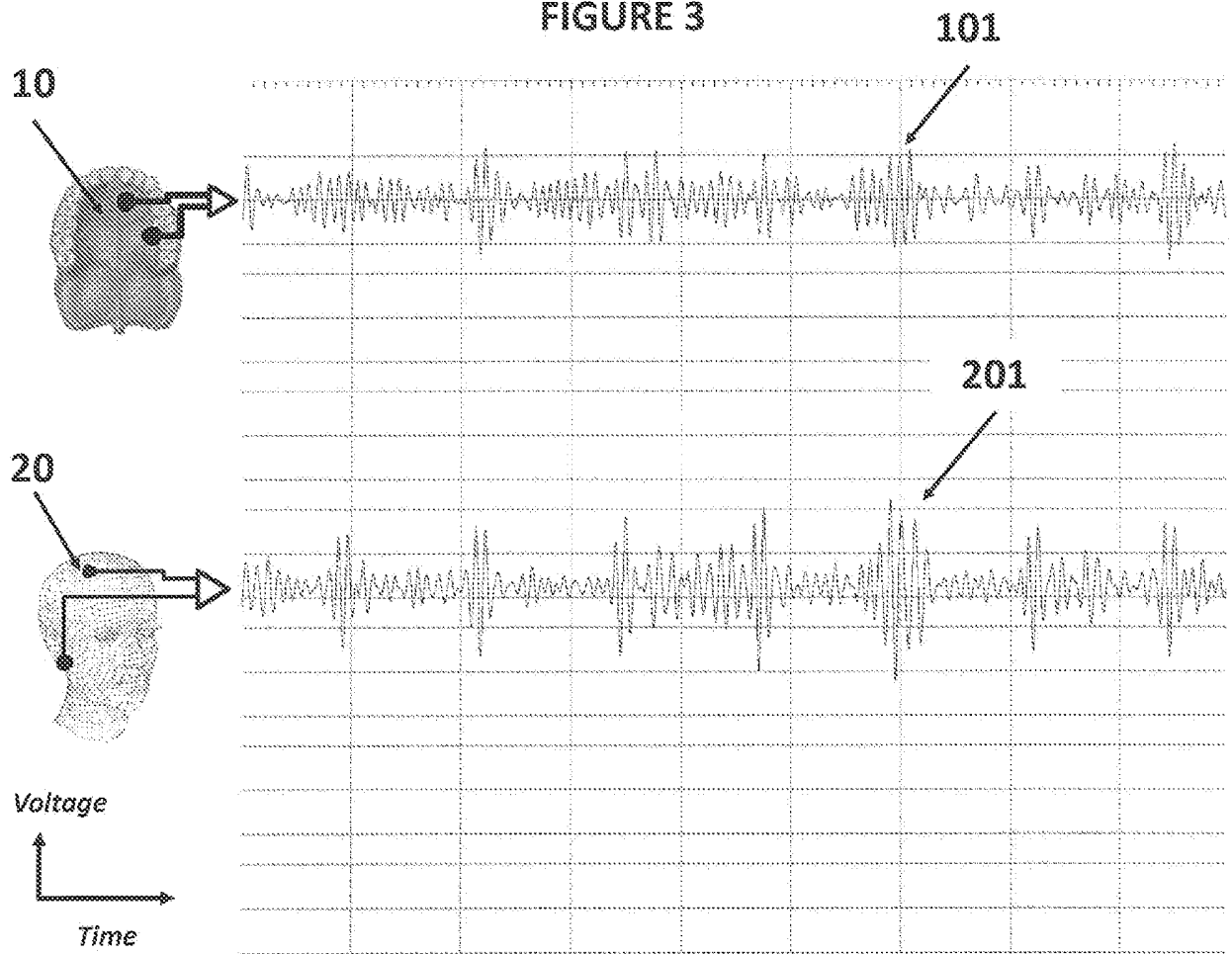

FIGURE 4

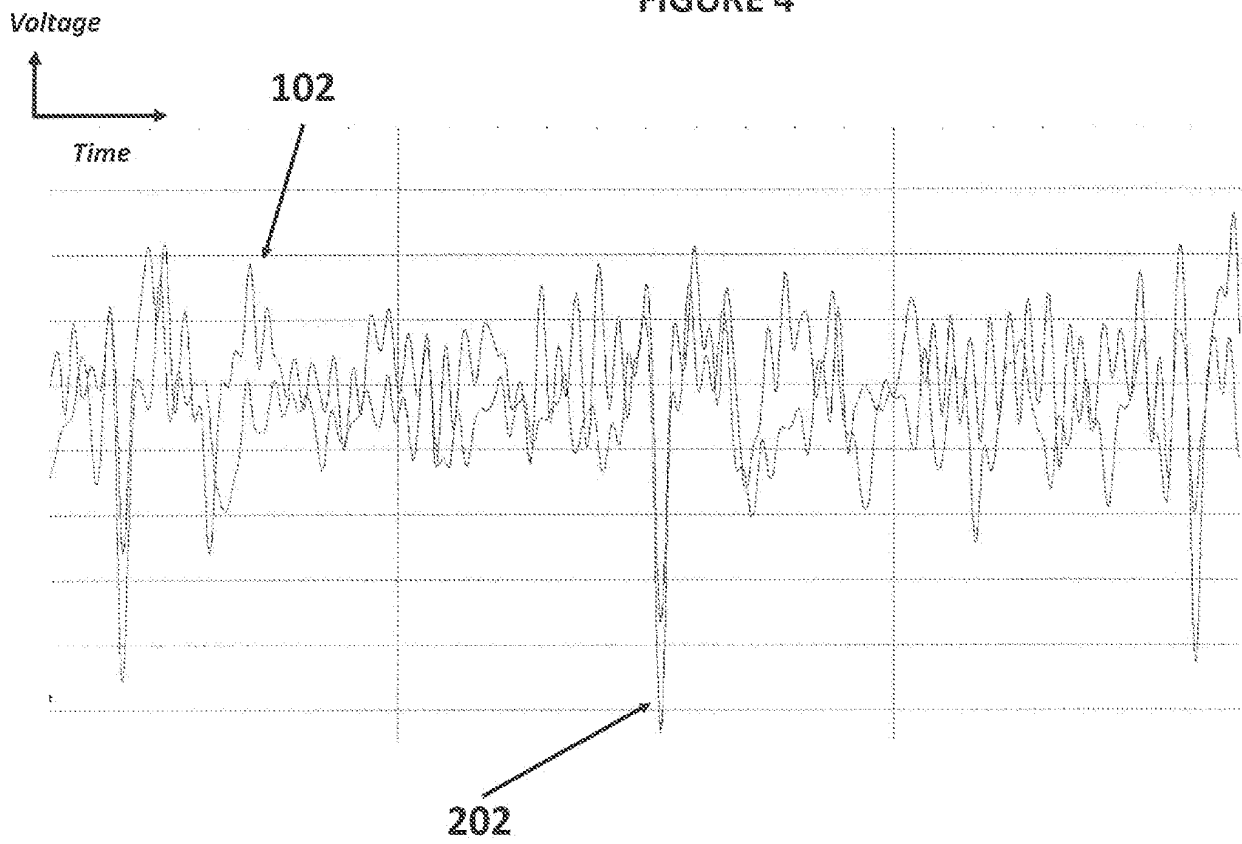

FIGURE 5

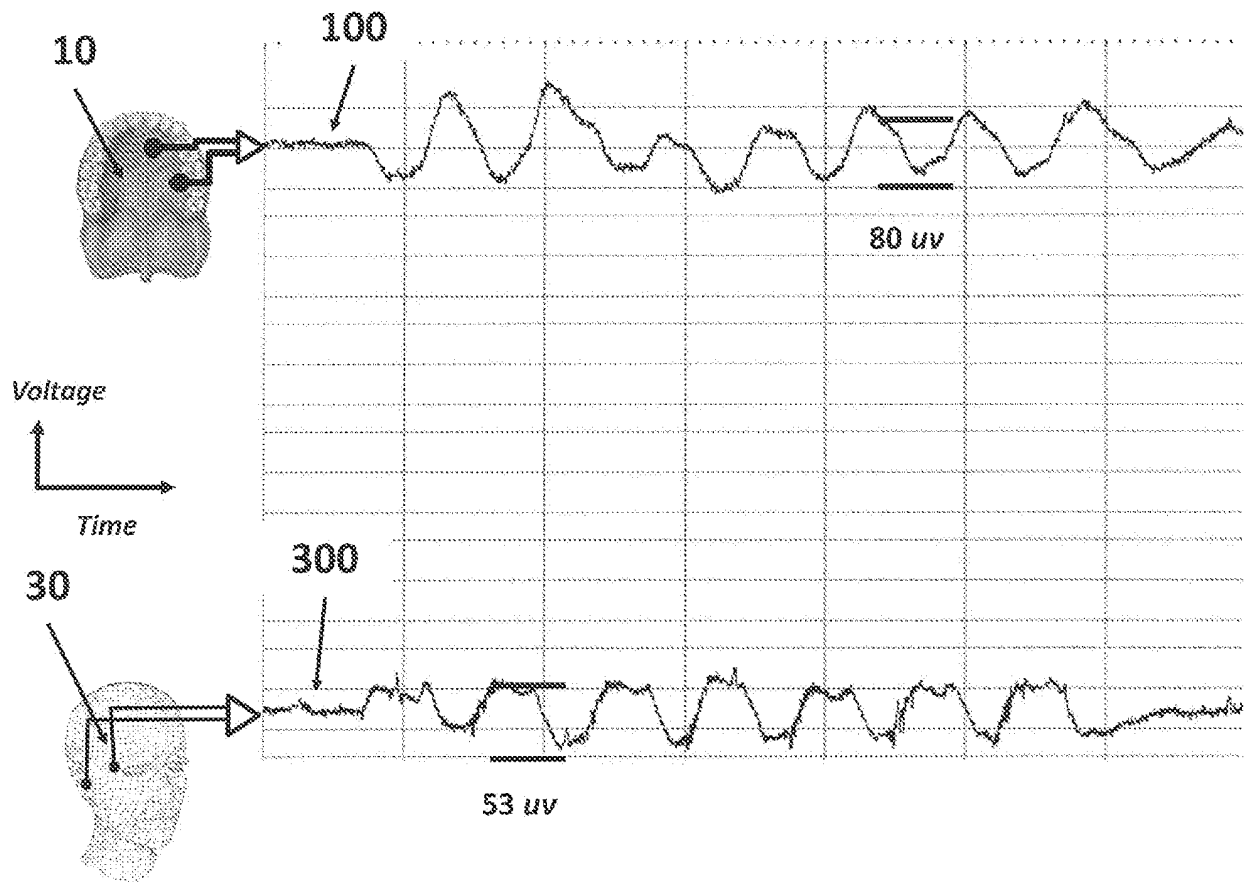

FIGURE 6

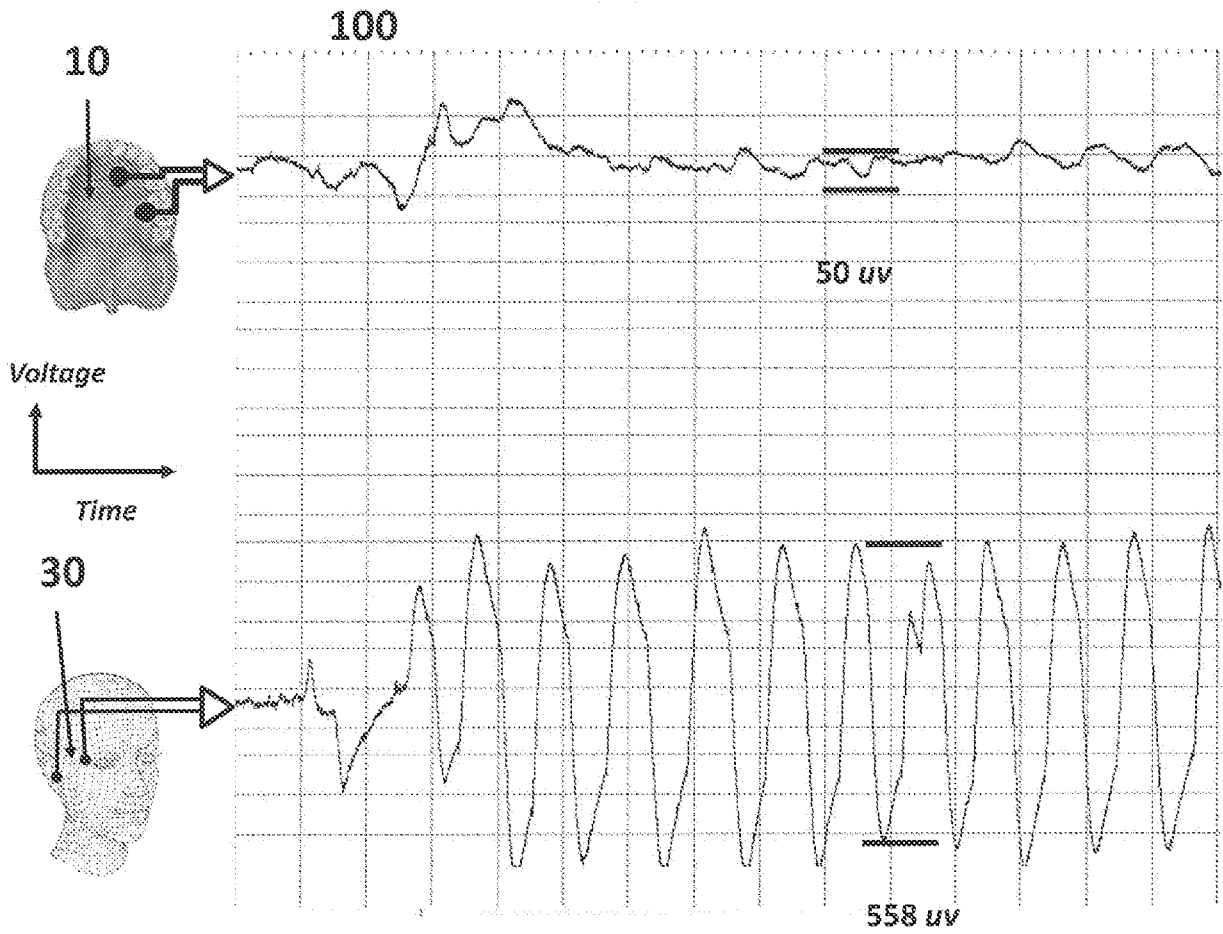

FIGURE 7

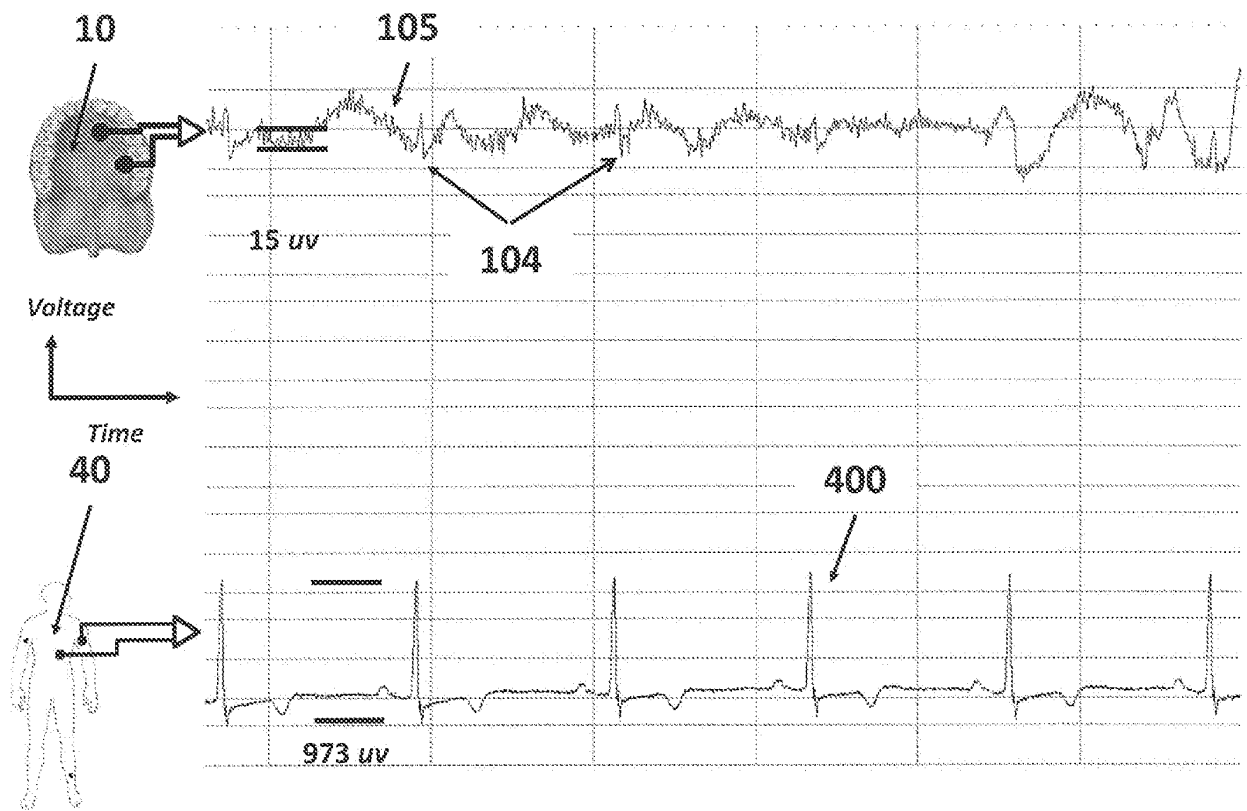

FIGURE 8

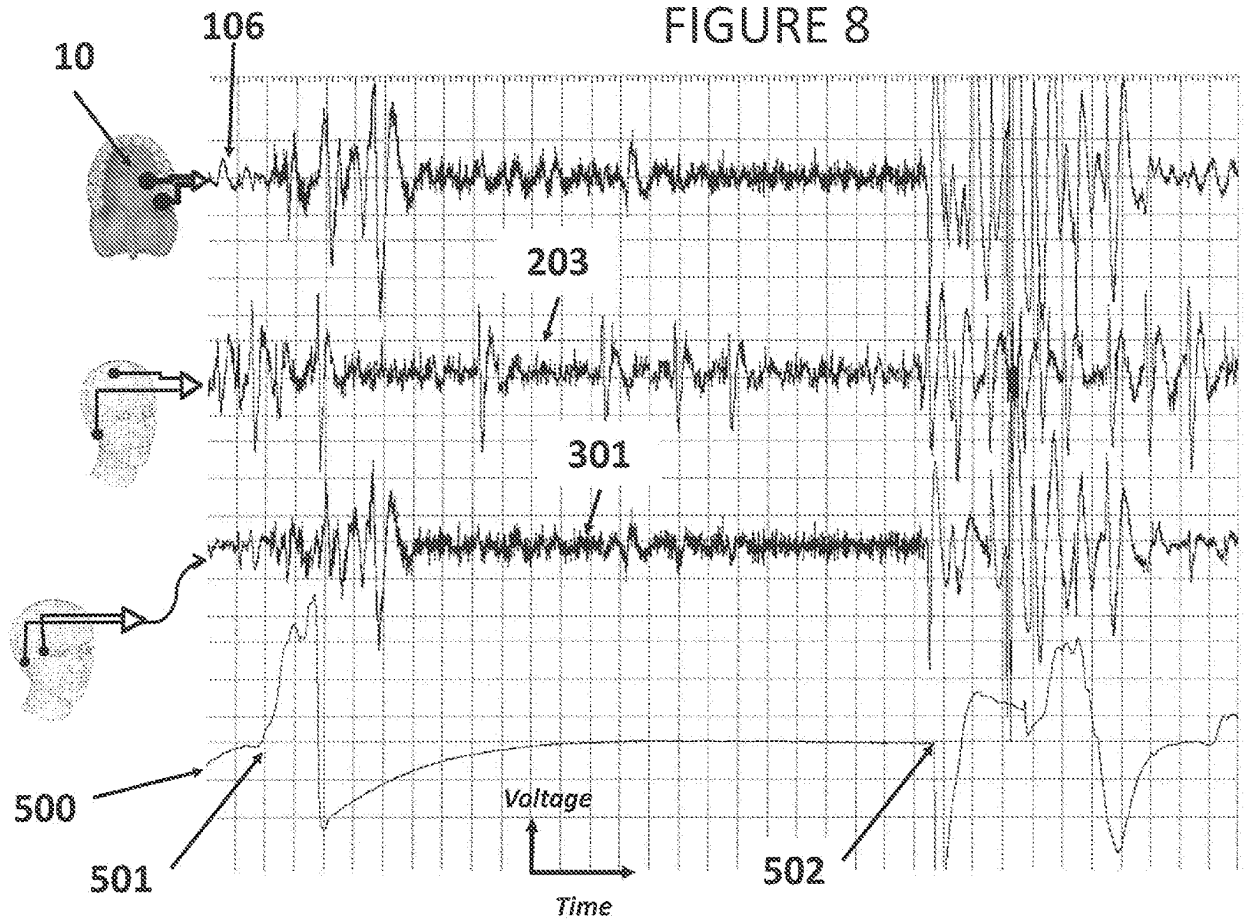
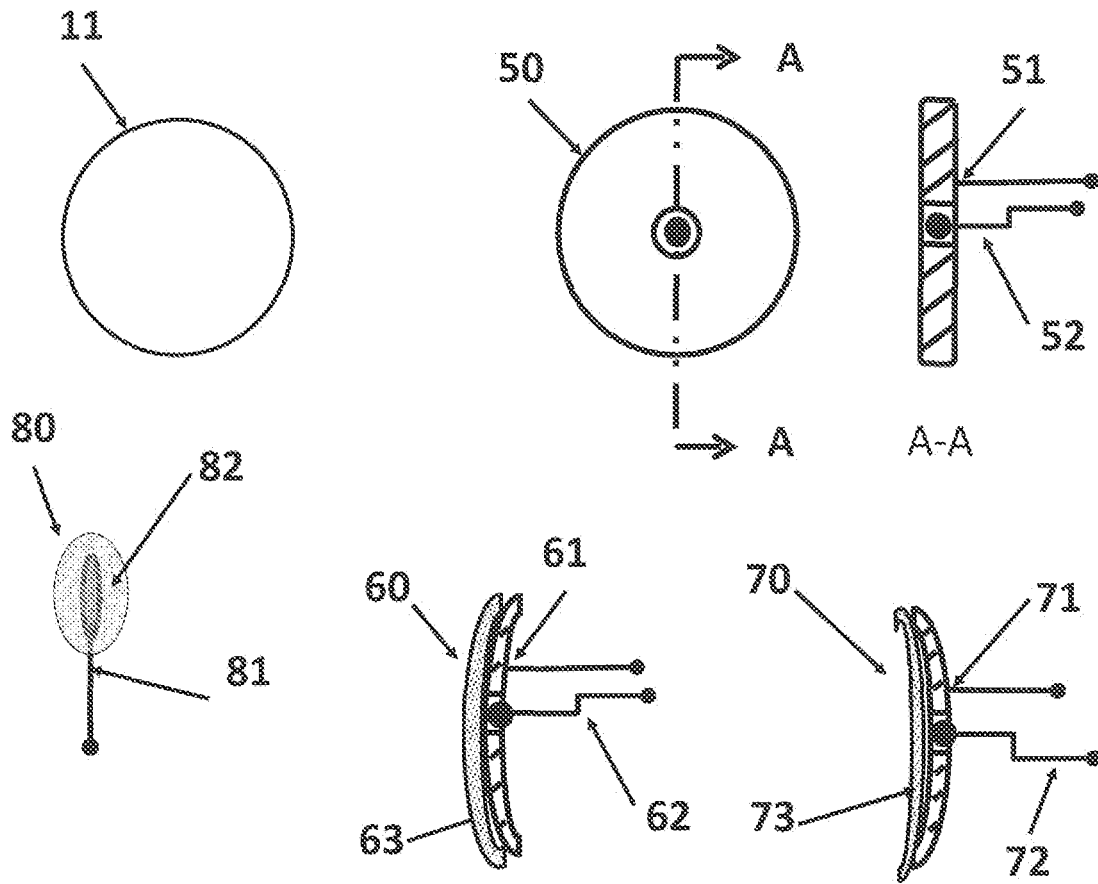

FIGURE 9



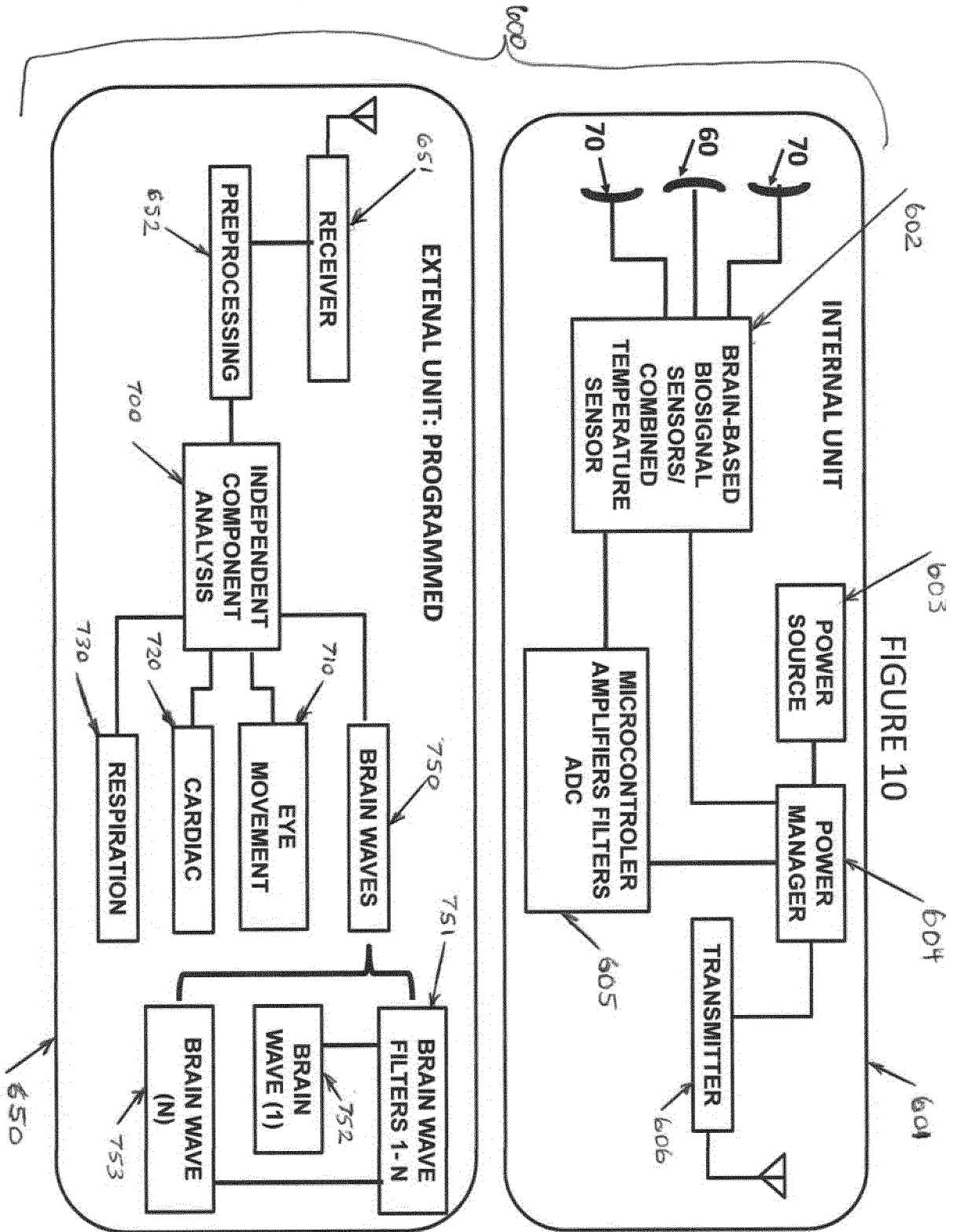

FIGURE 11

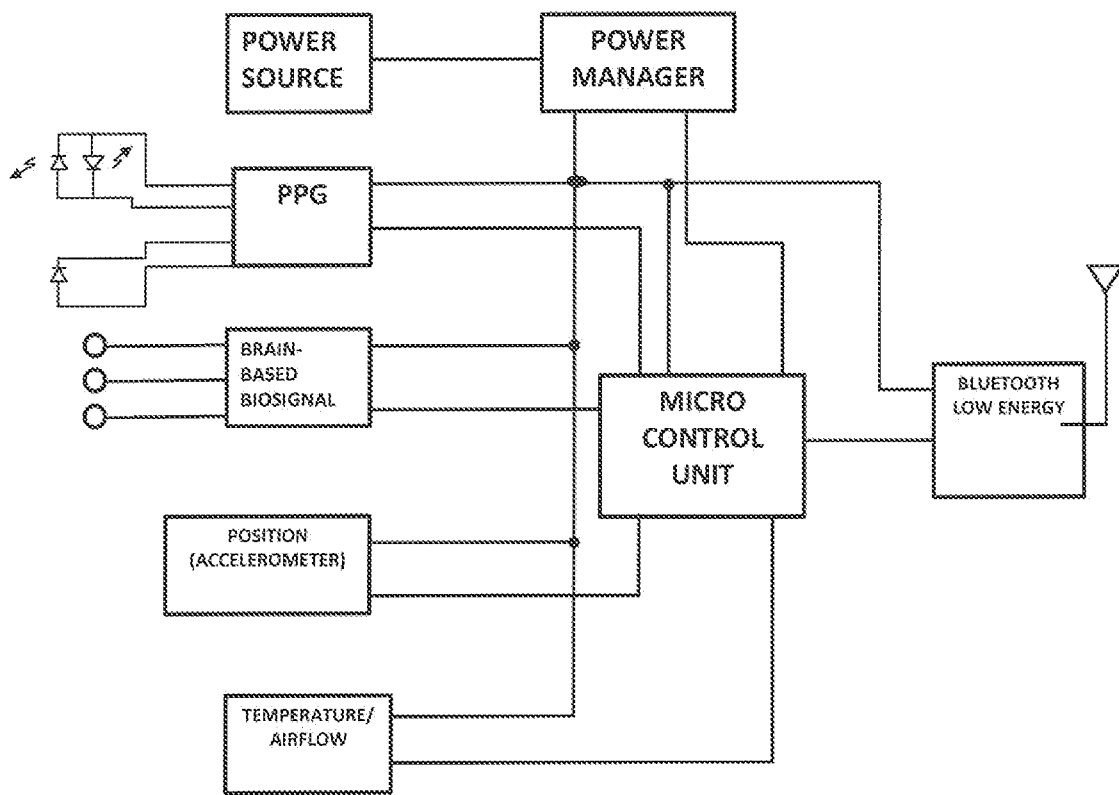

FIGURE 12

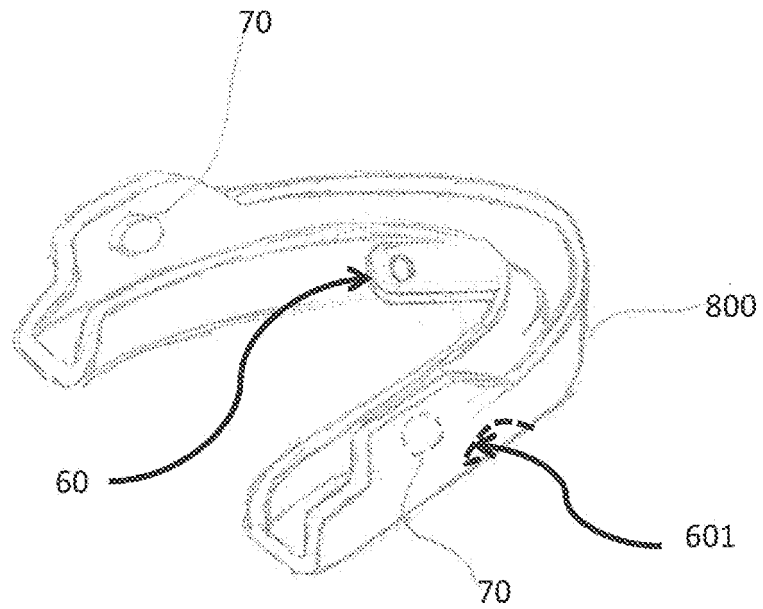

FIGURE 13

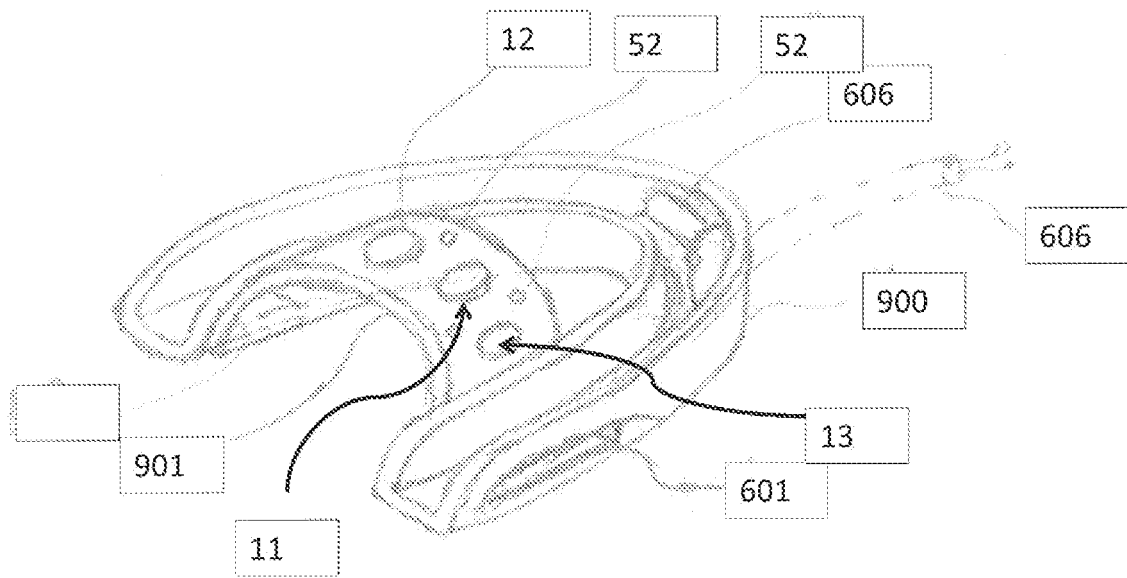

FIGURE 14

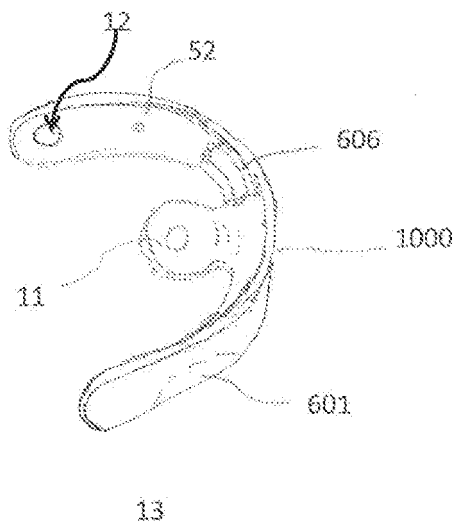
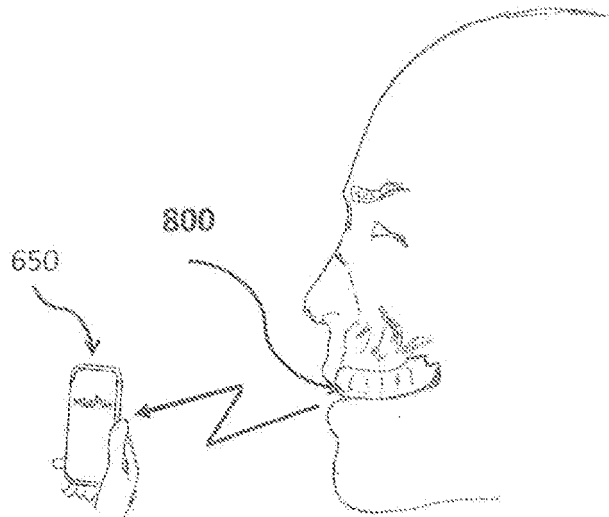

FIGURE 15



REFERENCES CITED IN THE DESCRIPTION

This list of references cited by the applicant is for the reader's convenience only. It does not form part of the European patent document. Even though great care has been taken in compiling the references, errors or omissions cannot be excluded and the EPO disclaims all liability in this regard.

Patent documents cited in the description

- US 61717907 [0001]
- US 61790007 [0001]
- WO 2012027648 A [0005]

专利名称(译)	用于检测基于脑的生物信号的系统和方法		
公开(公告)号	EP2911578A4	公开(公告)日	2016-08-10
申请号	EP2013849498	申请日	2013-10-24
[标]申请(专利权)人(译)	梦境医疗		
申请(专利权)人(译)	梦境医药有限责任公司		
当前申请(专利权)人(译)	梦境医药有限责任公司		
[标]发明人	WALKER ELIJAH CHARLES KIMANI MWANGI ANTHONY P		
发明人	WALKER, ELIJAH, CHARLES KIMANI MWANGI, ANTHONY, P.		
IPC分类号	A61B5/00 A61B5/0478 A61B5/04		
CPC分类号	A61B5/04005 A61B5/04012 A61B5/4064 A61B5/682 A61B5/6832 A61B3/113 A61B5/0022 A61B5/0205 A61B5/08 A61B5/4818		
优先权	61/717997 2012-10-24 US 61/790007 2013-03-15 US		
其他公开文献	EP2911578B1 EP2911578A2		
外部链接	Espacenet		

摘要(译)

本发明包括用于通过包括至少两个电极的传感器来检测患者的内部组织中的基于脑的多组分生物信号，并通过与传感器通信地耦合的至少一个计算机处理器来数字化该系统和方法。多组分基于脑的生物信号，由至少一个计算机处理器隔离来自数字化多组分基于脑的生物信号的多个子组分信号，并比较来自一个或多个分离的子组分信号的分离数据。至少一个计算机处理器处理预定的基线数据，并响应于将所述隔离数据与基线数据进行比较，由所述至少一个计算机处理器生成对机器的指令和状况的视觉诊断中的至少一项。