



(12) EUROPEAN PATENT APPLICATION

(43) Date of publication:
13.12.2006 Bulletin 2006/50

(51) Int Cl.:
A61B 5/00 (2006.01) A61M 16/00 (2006.01)

(21) Application number: 06252952.4

(22) Date of filing: 07.06.2006

(84) Designated Contracting States:
AT BE BG CH CY CZ DE DK EE ES FI FR GB GR
HU IE IS IT LI LT LU LV MC NL PL PT RO SE SI
SK TR
Designated Extension States:
AL BA HR MK YU

(72) Inventors:
• Schermeier, Olaf
23560 Lübeck (DE)
• Ziermann, Frank
20146 Hamburg (DE)

(30) Priority: 08.06.2005 DE 102005026562

(74) Representative: Greenwood, John David et al
Graham Watt & Co LLP
St Botolph's House
7-9 St Botolph's Road
Sevenoaks
Kent TN13 3AJ (GB)

(71) Applicant: Dräger Medical AG & Co. KG
23542 Lübeck (DE)

(54) Multi-part medical system

(57) The invention relates to a multi-part medical system which includes at least two components connectable via position-determining connection means (410, 411), whereby at least one component (44) is intended to remain close to the patient in the connected and in the unconnected state of the system and at least one com-

ponent (41) can be removed or replaced by other components in the unconnected state, whereby the component (44) intended to remain close to the patient contains means for data storage (45), which can be written or read out via an interface (46) which is mechanically integrated into the position-determining connection means (410, 411).

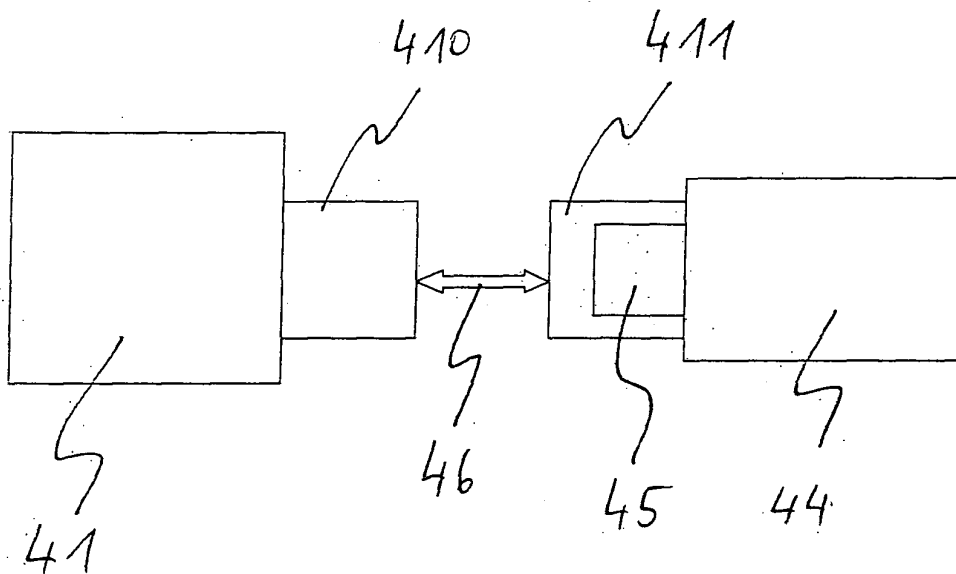

Fig. 4

Description

[0001] The invention relates to a multi-part medical system with a multi-functional interface.

[0002] Medical systems are characterised by increasing complexity and modularity. Before a medical system can be used at all, a plurality of components usually has to be connected. Numerous interfaces usually have to be connected using means of connection, and this can give rise to a high outlay, a high risk of error and possibly problems with availability.

[0003] Apart from connections that are required to produce various material flows, increasing importance is being attached to possible ways of creating data connections. During medical treatment, numerous items of information must permanently be kept available. At the same time, an abundance of other data arises during the treatment of patients, and these have to be recorded and/or taken into account in therapeutic decisions. A loss of such data, which can certainly occur under the time pressure that usually prevails, requires increased outlay on data recovery or on further data collection. Numerous data interfaces are known that are connected with separate cables or other means of connection in order to allow medical components to communicate with one another.

[0004] Furthermore, it is known to provide external data carriers with data records in order to be able to undertake a speedier adaptation of medical components when the need arises. Thus, for example, it is known to clear or block certain operating or operator modes on medical apparatuses by means of external data carriers (DE 101 16 650 A1). Furthermore, it is known to carry out an adaptation of such apparatuses to the requirements of individual operators by means of external data carriers and the connection thereof to complex, computer-controlled medical equipment (DE 196 25 410 A1).

[0005] Finally, it is known to store, on an external data memory, adjustment and parameter sets of medical apparatuses, for example an ECG monitor, that have arisen during a treatment, and to input this memory after replacement of the given apparatus by the interchanged apparatus. The necessity of having to transfer parameter sets and settings manually is thus no longer present (DE 198 09 952 A1).

[0006] The common feature with the preceding examples of the prior art is the fact that in each case an external data carrier, which is specially configured for storing and keeping available special data records, has to be connected to a medical apparatus in order to provide the full operational capability. This gives rise on the one hand to separate manoeuvres and requires increased awareness, since such data carriers, usually designed as a chip card, can quickly be lost in working procedures taking place under great pressure of time, which would lead to a considerable hold-up or subsequent expenditure.

[0007] The present invention is as claimed in the claims.

[0008] The present invention provides a possible way of reducing the risk of incorrect operations or data loss in complex medical systems, without having to incur a greatly increased outlay.

5 **[0009]** The invention essentially proceeds from two starting points. The first starting point is the fact that numerous multi-part medical systems have connection elements, with the aid of which individual components can be connected together. These connection elements in many cases necessitate precise positioning to permit a connection to be made.

10 **[0010]** In particular, fluid interfaces often have suitable connection means which are connected together in order to achieve a substance exchange. The requirement for the tightness of such fluid interfaces that usually exists means that they must be positioned very precisely for a correct connection, or they are designed, by means of suitable guide means, in such a way that incorrect positioning is for the most part ruled out.

15 **[0011]** Another starting point of the invention proceeds from the fact that, in modern medical systems, components are often present that are intended to remain for a lengthy period close to the patient, whereas other components are replaced more often or are connected only for a short time to the patient or to the medical system. If means for data storage are connected to such a component that remains for a lengthy period close to the patient, a loss of this data carrier during the period when the component remains close to the patient is virtually ruled out. Furthermore, if the component that remains close to the patient for a lengthy period is equipped for this purpose with a data carrier which is addressable via an interface mechanically integrated into the already mentioned connection means, it is moreover guaranteed that, in the case of the connected components, the data carrier is on the one hand available and on the other hand the interface for addressing the data carrier is precisely positioned with respect to other components that are connected to the component remaining close to the patient. Particularly precise positioning results when the interface for addressing the data carrier is mechanically integrated into a fluid interface, via which a connection of the component remaining close to the patient with other components of the multi-part medical system takes place.

20 **[0012]** The invention consists in a multi-part medical system, which includes at least two components connectable via position-determining connection means, whereby at least one of the components is intended to remain close to the patient in the connected and in the unconnected state of the system and at least one component can be removed or replaced by other components in the unconnected state, whereby the component intended to remain close to the patient contains means for data storage, which can be written or read out via an interface which is mechanically integrated into the position-determining connection means. Position-determining connection means is understood to mean means which must occupy a defined position in respect of one

another in order to permit the desired connection to be made.

[0013] To advantage, the interface contained according to the invention for addressing the means for data storage may be integrated into a fluid interface. A fluid interface within the meaning of the invention is any connection system which can enter into an interaction via shaped pieces complementary with one another, whereby a sealing effect is achieved in a keyed or friction-locked manner and an exchange of a fluid through the connected interface can take place in the connected state. Typical fluids are respiratory gases or liquids during intensive-therapeutic measures.

[0014] The connection means connectable to one another, or more precisely the parts of the fluid interface connectable to one another, are connected at least with sufficient dimensional stability to means for a data transmission in a way which ensures that, in the case of the components of the medical system according to the invention connected to one another, the means of data transmission, which form the interface for addressing the data memory, are at least arranged in such a way that data transmission can take place. This principle of linking means for a data transmission to parts of a fluid interface connectable to one another or other position-determining connection means connectable to one another is understood as integration within the meaning of the invention.

[0015] The connection of means for data storage to a component that remains for a lengthy period close to the patient is automatically associated with the fact that no further manoeuvres are required to make the data memory available and the latter can never be forgotten. The effect of integrating the means for data transmission into an interface which in any case has to be connected to complementary parts for the operation of the medical system, furthermore, is that no additional manoeuvres are required for the connection of the means for data storage to a writer or reader unit located in another component of the medical system, and this greatly assists with a procedure under pressure of time.

[0016] Respiratory tube systems, in particular, come into consideration as components that are intended to remain for a lengthy period close to the patient. According to the invention, these respiratory tube systems are equipped with means for data storage. Components of a medical system according to the invention that can be routinely removed from the patient or replaced may, for example, be respiratory apparatuses.

[0017] Alternatively, other components that remain for a lengthy period close to the patient can be equipped with means for data storage according to the invention. These components can contain, in particular, at least a tube, a mask body, a filter, an SPO₂ sensor, ECG electrode sets or body-temperature sensors or catheters. All these components are as a rule designed in such a way that they can be connected without problem via interfaces, in some cases even fluid interfaces, to further components of the medical system.

[0018] It is particularly advantageous for the interface according to the invention to be equipped with means for contactless data transmission, which is advantageous especially when dealing with oxygen to avoid any ignition hazard.

It is without doubt advantageous for the means for data storage and/or data transmission to be designed in such a way that they are suitable for the storage and transmission of respiratory parameters, which enables a convenient exchange of equipment, especially when use is being made of varied respiratory apparatuses during the treatment of a patient.

[0019] In an advantageous development of a system according to the invention, the means for data storage and/or data transmission are designed in such a way that they are suitable for the storage and transmission of information via the components connected by means of the interface. This is an advantageous variant, for example, in the case of the use of respiratory tube systems which can easily be confused with one another. In this case, the system can automatically recognise the connected type of tube.

[0020] In more convenient, multi-part medical systems with an interface according to the invention, the means for data storage and/or data transmission are designed in such a way that they are suitable for the storage and transmission of patient data, therapy data and/or diagnostic data. In this way, the means for data storage can in part assume the function of an electronic patient record and necessary data can automatically be made available to the doctor giving treatment at the time.

[0021] It has proved to be particularly advantageous for the means for data transmission and/or data storage to be components of an RFID system.

[0022] Alternatively, the means for data transmission and/or data storage can be components of a system which is based on magnetic or optical data storage and/or data transmission. 1-wire technology represents a further advantageous alternative.

[0023] In order to prevent unauthorised access to the stored data, it is advantageous for the data to be encoded and only to be made available when read out through a suitable decoding process. For this purpose, it is necessary for means of encoding and decoding the transmitted and/or stored data to be contained.

[0024] Furthermore, it is advantageous for means to be contained that make it possible to store manually information which prohibits further use of the component intended to remain with the patient. These include, for example, a manual switch which ensures the transmission and storage of a blocking code when actuation takes place. If this code is read out subsequently, the medical system requests replacement of the blocked components. This can be expedient in the case of unclear infection risks and obvious damage.

[0025] Embodiments of the invention will now be described, by way of example only, with reference to the accompanying Figures, of which:

Fig. 1 is a schematic diagram of a multi-part medical system according to the invention in the form of a respiratory system,

Fig. 2 is a schematic block diagram of a multi-part medical system according to the invention,

Fig. 3 is a schematic diagram of a respiratory system according to the invention in the area of the fluid interface,

Fig. 4 is a schematic diagram of the general structure of a multi-part medical system according to the invention.

[0026] The respiratory system equipped according to the invention includes a respiratory tube system with a memory element as a component which, within the meaning of the invention, is intended to remain for a lengthy period close to the patient. As components that can be routinely removed from the patient or replaced, respiratory apparatuses are included that have a reader and writer unit, which can communicate with the memory element when the respiratory tube apparatus is connected. This offers numerous advantages over conventional respiratory systems, as explained in the following.

[0027] There are a large number of different types of respiratory tube and respiratory tube systems (collectively "respiratory tube means"). Thus, there are single-use and multiple-use tubes, different tube lengths, different diameters, double-tube systems, coaxial tubes, tubes with a semi-permeable membrane for the passage of moisture, tubes heated by electrical heating wires, tubes with temperature sensors and flowmeters.

[0028] Many patients are provided with artificial respiration as part of their medical care, whereby different respiratory systems may be used one after the other in the course of the treatment.

[0029] Each combination of a specific type of tube with a specific respiratory apparatus requires specific respiratory parameters or excludes other respiratory parameters. Furthermore, respiratory parameters must be selected according to therapeutic aspects. The main parameters are the form of respiration, the oxygen content, the respiratory frequency, where appropriate the stroke volume, the maximum volume, the respiratory pressure and a maximum permissible pressure.

[0030] Respiratory systems available at present require that the individual patient respiratory parameters are set manually by the user on each apparatus in order to ensure optimum treatment.

[0031] The optimum setting of the parameters depends on a large number of individual patient factors which describe the respiratory requirement. The optimum setting of the respiratory parameters therefore requires a considerable expenditure of time by the staff in attendance.

[0032] After the start of the medical care, a patient usu-

ally passes through various stations. These may be: rescue vehicle/helicopter, ambulance, induction, OP, emergency, intensive care unit and various in-patient or out-patient forms of transport. If respiration is required for a patient, the parameters have to be reset by the staff for each respiratory system along this chain in the case of conventional systems.

[0033] The described expenditure and the risk of errors are reduced considerably by the use of a respiratory system equipped according to the invention. Respiratory parameters can be stored as data records in the memory element, which is integrated into the respiratory tube system. The respiratory tube system remains with the patient when the clinical area or the respiratory apparatus are changed. After another respiratory apparatus has been connected up, these data are available for the newly connected respiratory apparatus, which enables an automatic or semi-automatic setting of the required respiratory parameters. Furthermore, data can be stored concerning forbidden parameters which must not under any circumstances be set when the given type of tube is used, and this reduces considerably the risk of patients receiving incorrect care. In addition to or as an alternative to the respiratory parameters, data concerning treatment that has taken place can be stored in the memory element and subsequently read out for accounting purposes. For example, the performed respiratory minutes can thus be recorded.

[0034] Fig. 1 shows a multi-part medical system according to the invention in the form of a respiratory system. The example of embodiment concerns a system comprising at least two, in the present case three, respiratory apparatuses 1, 2, 3 and at least one respiratory tube system 4, whereby the respiratory apparatuses are capable of storing and reading out in a contactless manner individual patient respiratory parameters on a memory element 5 on respiratory tube system 4 when one of respiratory apparatuses 1, 2, 3 is connected to respiratory tube system 4. The respiratory apparatuses are an emergency respiratory apparatus 1, an intensive-care respiratory apparatus 2 and an anaesthesia respiratory apparatus 3, such as may be used at different times on a patient.

[0035] The connection takes place in such a way that respiratory parameters from a respiratory apparatus are stored in each case by a writer and reader unit 6, 6', 6" on memory element 5 of respiratory tube apparatus 4 and these parameters are read out by the other respiratory apparatuses from memory element 5 in respiratory tube system 4 and can thus be set automatically or semi-automatically by the individual respiratory apparatuses. The effect of this is that the respiratory parameters set on the first respiratory apparatus, after re-plugging of the respiratory tube system to another respiratory apparatus, are also set on the latter.

[0036] Basic requirements on respiratory tubes are described in EN12342. The standard also defines the mechanical interface to the respiratory system, which is usu-

ally designed via a conical male connector to the respiratory system and a female connector to the respiratory tube. The usual standards of 22 mm, 15 mm and 10 mm diameter are available for the connectors. This connector system represents a fluid interface within the meaning of the invention, which in the connected state ensures the precise positioning of the shaped pieces in contact with one another.

[0037] Each respiratory apparatus automatically stores all the settings of the respiratory parameters on the memory element in the respiratory tube system. After re-plugging of the tube to another respiratory system, the latter automatically reads out the data last stored on the memory element and sets the latter on the new respiratory system. If necessary, this can take place by retrieval and confirmation on a display screen. If, in turn, any change is made to the settings in the system, this is automatically stored in the memory element and, when the occasion arises, is transferred to another respiratory system. In order not to change the process within the clinical procedure, a passive, cableless memory element is used which can be read out without further work steps.

[0038] The advantage of the solution for the user lies in the significant simplification of the clinical processes and thus in a reduction in costs as a result of fewer and shorter work steps.

[0039] The expensive manual patient-specific programming of each individual respiratory apparatus is no longer required and is replaced by a brief retrieval. After a change of the clinical area or the respiratory system, the setting of optimum respiratory parameters can be carried out in a matter of a few seconds, something which in conventional systems takes much more time.

[0040] Furthermore, optimum treatment of the patient is ensured in all areas, since incorrect operation of the system is largely eliminated. As a result of the further use of optimised respiratory parameters on different apparatuses, it is possible to achieve a stable and lastingly optimised respiratory state.

[0041] The communication between the respiratory tube system and the respective respiratory apparatus takes place in the example of embodiment via a contactless data connection.

[0042] The memory element takes the form of an RFID chip, a so-called tag, in the tube socket. The former is either glued on or injection moulded. It is arranged geometrically in the tube socket in such a way that it can be read out or written on via an antenna by a writer and reader unit in the respiratory apparatus when the respiratory tube system is connected up to the respiratory apparatus.

[0043] RFID performs an inductive process, in which an antenna on a tag is excited at a defined frequency. A small chip on the RFID tag then returns the stored information. There are large number of different RFID standards and RFID tags with varying functionality.

[0044] Fig. 2 shows a block diagram of a multi-part medical system according to the invention in the form of

a respiratory system. Respiratory apparatus 1 itself contains a control unit 7, which controls all the sequences occurring during the operation of the apparatus. Data required for this can be inputted via an operator unit 8. Respiratory tube system 4 which can be connected to respiratory apparatus 1 has an RFID tag as a memory element 5. A writer and reader unit 6 in respiratory apparatus 1 can communicate with this RFID tag, which takes place via a suitable antenna 9. Writer and reader unit 6 can also relay data read out from the RFID tag to control unit 7. If the RFID tag contains data concerning respiratory parameters, the latter can replace an input via the operator unit. Instead, the read-in respiratory parameters are displayed at operator unit 8 and accepted as a setting by a clearance given by the user.

[0045] The RFID tag is already written with various data in the as-delivered state of the respiratory tube system. The latter contain information in the form of an identification number and a manufacturer's code and enable the time of manufacture and other specific data to be read out. Furthermore, respiratory parameters are stored which must not be set with the respiratory tube system. For example, when a respiratory tube system is being used for neonates, it is thus possible to prevent large stroke volumes being set on the respiratory apparatus that would be typical for respiration in the case of adult patients.

[0046] If the respiratory apparatus recognises the RFID tag, this means that a tube is connected. Any respiratory parameters already stored on the RFID tag are then regularly compared with the respiratory parameters set in the apparatus software and, when a change has been made by the user, are stored on the RFID tag. Conversely, after the connection of the respiratory tube system to a respiratory apparatus, the stored respiratory parameters are read out from the RFID tag via the writer and reader unit and are used automatically or semi-automatically, after clearance, for the setting of the respiratory mode, which usually takes place through apparatus software.

[0047] Figure 3 shows a respiratory system according to the invention in the area of the fluid interface. A respiratory gas connection with an angle-adjustable male connector 10 is fitted to a respiratory apparatus 1. The connection of a respiratory tube system 4 is made to this connector 10, whereby a sealing socket 11 as a female connector is connected to male connector 10. An RFID tag, which cannot be seen in the present illustration, is connected to an antenna 12. In the present example, a coil is injection-moulded into socket 11 as antenna 12 of the tag, in such a way that its windings are directed normal to the axis of the tube connection. Antenna 9 of a writer and reader unit on the apparatus side is fitted in this variant at right angles to the axis of the part of respiratory gas connection 13 rigidly connected to respiratory apparatus 1. It thus follows that, with all the positions of the angle-adjustable male connector 10 (except for a connector bent down at right angles), the fields that are

formed around antennas 9, 12 exhibit in each case a parallel component with respect to the receiving antenna, which ensures an inductive coupling that is adequate for the performance of the invention.

[0048] Figure 4 again shows the general structure of a multi-part medical system according to the invention. This is a multi-part medical system which includes at least two components that can be connected via position-determining connection means 410, 411, whereby at least one component 44 is intended to remain close to the patient in the connected and in the unconnected state of the system and at least one component 41 can be removed or replaced by other components in the unconnected state, whereby component 44 intended to remain close to the patient contains means for data storage 45, which can be written and read out via an interface 46 which is integrated mechanically into the position-determining connection means 410, 411.

Claims

1. A multi-part medical system, which includes at least two components which can be connected via position-determining connection means (410, 411), whereby at least one component (44) is intended to remain close to the patient in the connected and in the unconnected state of the system and at least one component (41) can be removed or replaced by other components in the unconnected state, **characterised in that** the component (44) intended to remain close to the patient contains means for data storage (45) which can be written and read out via an interface (46) which is integrated mechanically into the position-determining connection means (410, 411).
2. The multi-part medical system according to claim 1, in which the connectable components are connectable by position-determining connection means which are a component of a fluid interface.
3. The multi-part medical system according to claim 1 or 2, in which a respiratory apparatus (1) is contained as a component that can be removed from the patient.
4. The multi-part medical system according to claim 1 or 2, in which a respiratory tube system (4) is contained as a component intended to remain with the patient.
5. The multi-part medical system according to claim 1 or 2, in which at least a tube, a mask body, a filter, an SPO₂ sensor, an ECG electrode set, a catheter or a body-temperature sensor is contained as a component intended to remain with the patient.
6. The multi-part medical system according to any one of claims 1 to 5, in which means for a contactless data transmission are integrated.
7. The multi-part medical system according to any one of claims 1 to 6, in which the means for data storage and/or data transmission are designed in such a way that they are suitable for the storage and transmission of patient data, accounting data, therapy data and/or diagnostic data.
8. The multi-part medical system according to any one of claims 1 to 7, in which the means for data storage and/or data transmission are designed in such a way that they are suitable for the storage and transmission of respiratory parameters.
9. The multi-part medical system according to any one of claims 1 to 8, in which the means for data storage and/or data transmission are designed in such a way that they are suitable for the storage and transmission of information concerning the components connected by means of the interface.
10. The multi-part medical system according to any one of claims 1 to 9, in which the means for data storage and/or data transmission include an RFID system (5, 6, 9, 12).
11. The multi-part medical system according to any one of claims 1 to 9, in which the means for data storage and/or data transmission are a component of a 1-wire system.
12. The multi-part medical system according to any one of claims 1 to 9, in which the means for data storage and/or data transmission are suitable for optical data transmission and/or data storage.
13. The multi-part medical system according to any one of claims 1 to 9, in which the means for data storage and/or data transmission include at least one magnetic storage medium.
14. The multi-part medical system according to any one of claims 1 to 13, in which means for encoding and decoding the transmitted and/or stored data are contained.
15. The multi-part medical system according to any one of claims 1 to 14, in which means are contained which make it possible to store manually information which prohibits further use of the component intended to remain with the patient.

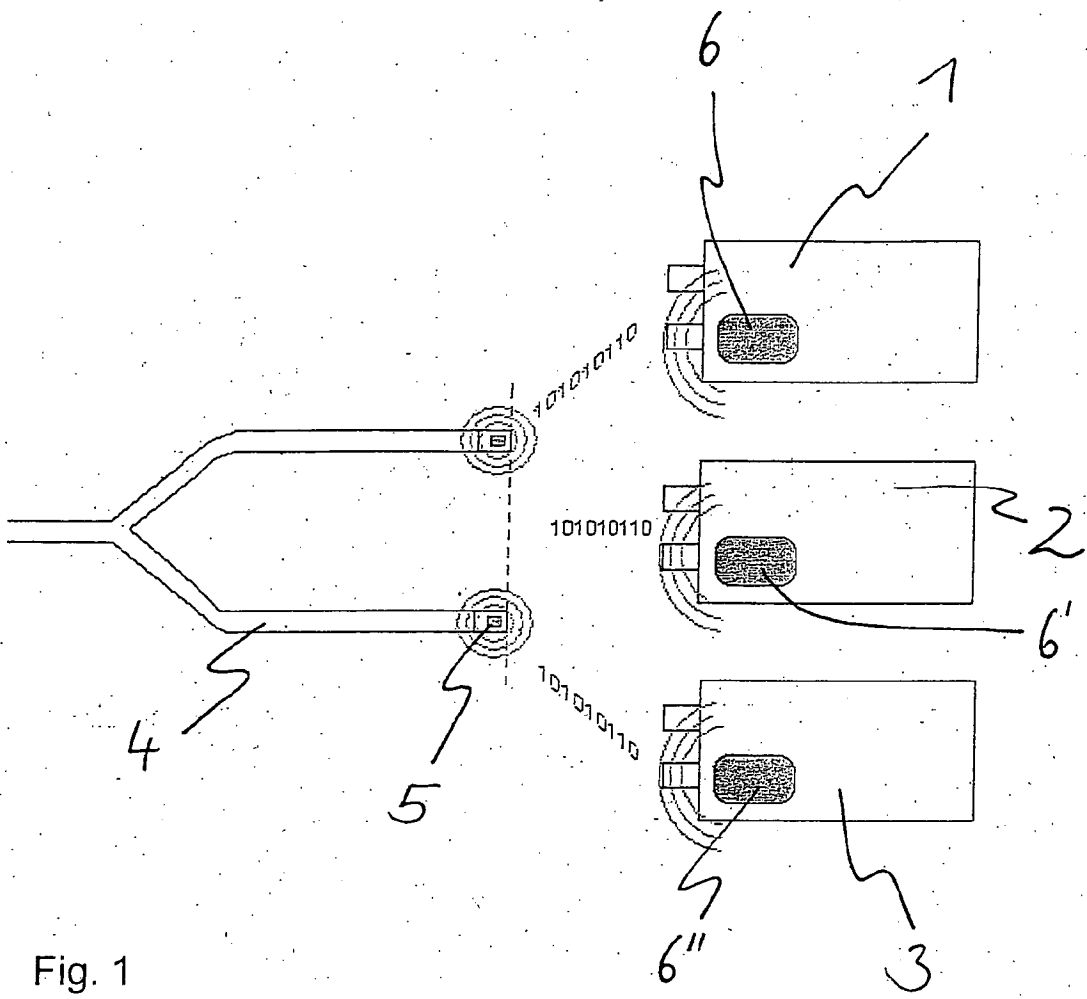

Fig. 1

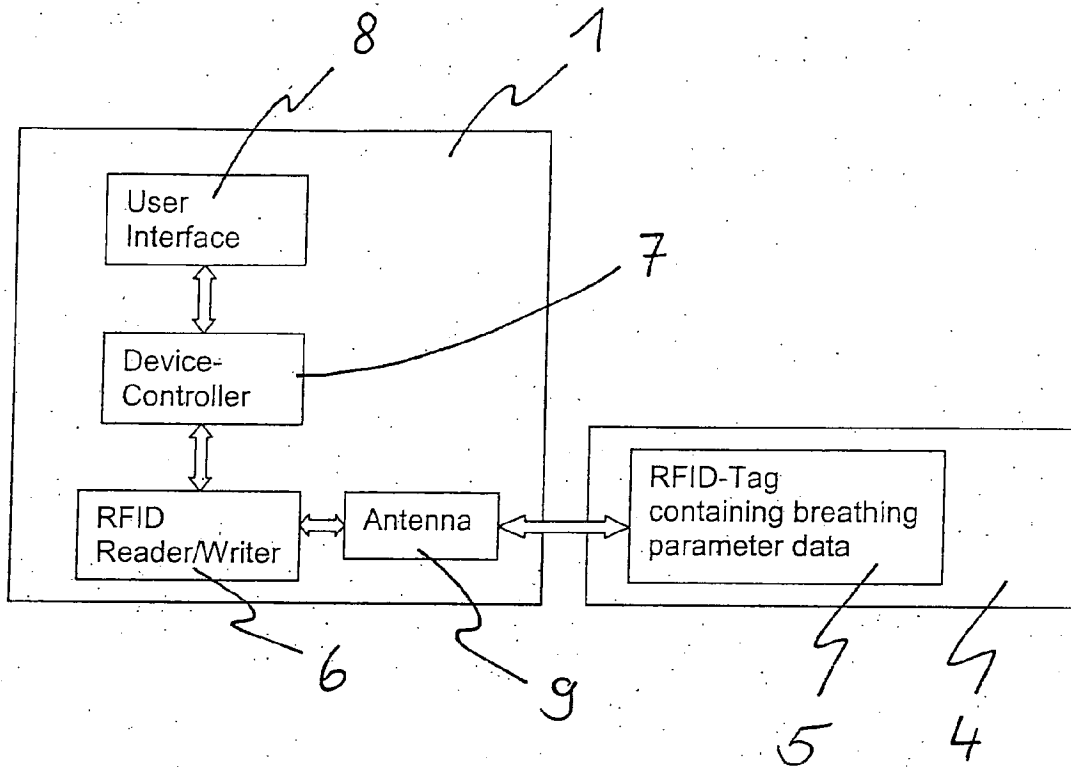

Fig. 2

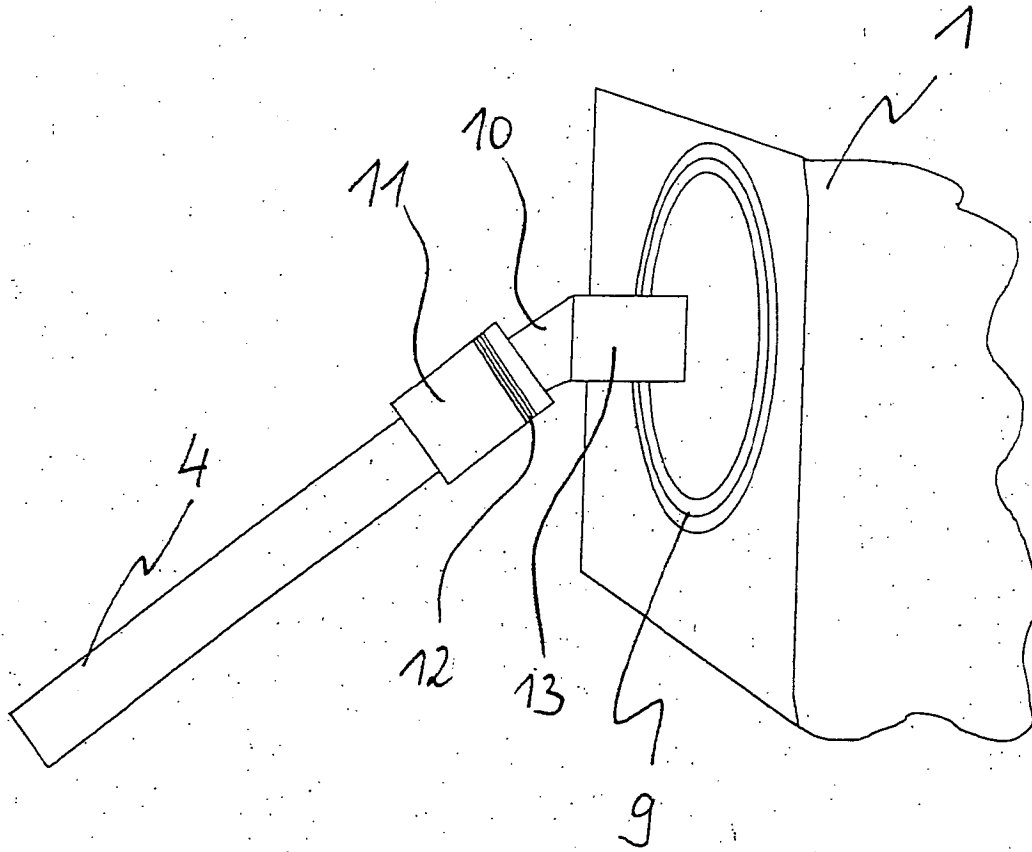

Fig. 3

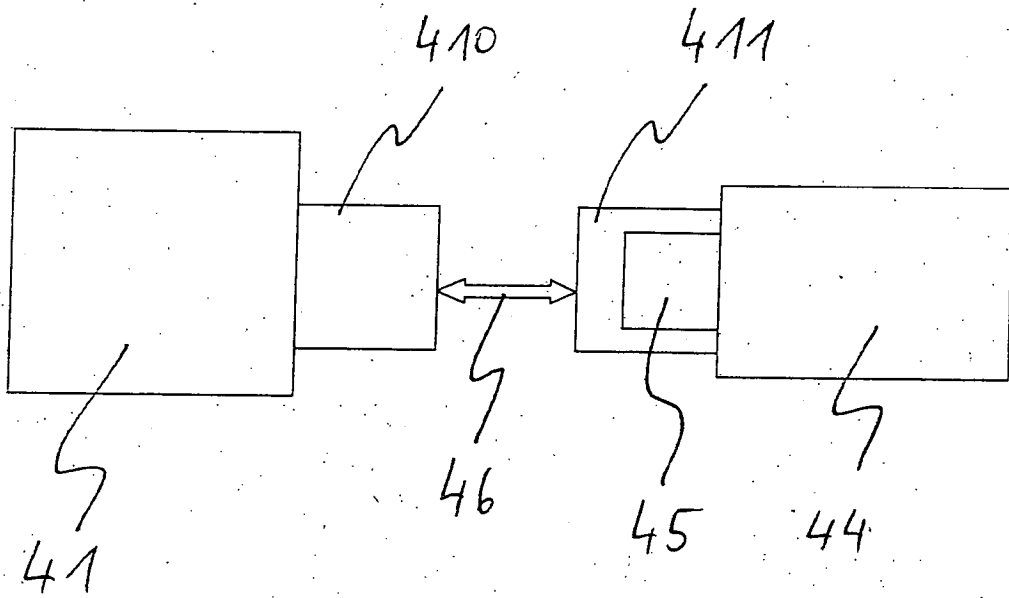

Fig. 4



DOCUMENTS CONSIDERED TO BE RELEVANT			
Category	Citation of document with indication, where appropriate, of relevant passages	Relevant to claim	CLASSIFICATION OF THE APPLICATION (IPC)
X	WO 00/61003 A (O.B. SCIENTIFIC, INC) 19 October 2000 (2000-10-19) * the whole document *	1,5,7,9, 11,13-15	INV. A61B5/00 A61M16/00
X	EP 0 571 225 A (PURITAN-BENNETT CORPORATION; PURITAN BENNETT CORP) 24 November 1993 (1993-11-24) * the whole document *	1,5,7,9	
X	WO 93/06776 A (INTERFLO MEDICAL, INC) 15 April 1993 (1993-04-15) * the whole document *	1,2,5,7, 9,14,15	
X	WO 02/02169 A (COMPUMEDICS SLEEP PTY. LTD) 10 January 2002 (2002-01-10) * the whole document *	1,3,6-8, 13,14	
X	WO 2004/095379 A (VASOGEN IRELAND LIMITED; LIM, BERNARD, C.B; MATSUURA, DAVID, G; SIMPSO) 4 November 2004 (2004-11-04) * the whole document *	1,2,7, 10,14	
A	US 2002/038392 A1 (DE LA HUERGA CARLOS) 28 March 2002 (2002-03-28) * the whole document *	1	TECHNICAL FIELDS SEARCHED (IPC) A61B A61M
A	DE 100 21 783 A1 (MAP MEDIZINTECHNIK FUER ARZT UND PATIENT GMBH & CO. KG) 30 November 2000 (2000-11-30) * the whole document *	1-4	
A	US 5 910 776 A (BLACK ET AL) 8 June 1999 (1999-06-08) * the whole document *	1,6,10	
The present search report has been drawn up for all claims			
Place of search Munich		Date of completion of the search 7 September 2006	Examiner Borowski, Aleksander
CATEGORY OF CITED DOCUMENTS			
X : particularly relevant if taken alone Y : particularly relevant if combined with another document of the same category A : technological background O : non-written disclosure P : intermediate document		T : theory or principle underlying the invention E : earlier patent document, but published on, or after the filing date D : document cited in the application L : document cited for other reasons & : member of the same patent family, corresponding document	

1
EPO FORM 1503 03/02 (P04C01)

**ANNEX TO THE EUROPEAN SEARCH REPORT
ON EUROPEAN PATENT APPLICATION NO.**

EP 06 25 2952

This annex lists the patent family members relating to the patent documents cited in the above-mentioned European search report. The members are as contained in the European Patent Office EDP file on The European Patent Office is in no way liable for these particulars which are merely given for the purpose of information.

07-09-2006

Patent document cited in search report		Publication date	Patent family member(s)	Publication date
WO 0061003	A	19-10-2000	AT 327712 T	15-06-2006
			CN 1450877 A	22-10-2003
			EP 1176909 A1	06-02-2002
			US 6308089 B1	23-10-2001
			US 7048687 B1	23-05-2006

EP 0571225	A	24-11-1993	CA 2096574 A1	22-11-1993
			JP 6070916 A	15-03-1994
			US 5357953 A	25-10-1994

WO 9306776	A	15-04-1993	CA 2120532 A1	15-04-1993
			DE 69225803 D1	09-07-1998
			DE 69225803 T2	02-09-1999
			EP 0606356 A1	20-07-1994
			JP 3547130 B2	28-07-2004
			JP 6511172 T	15-12-1994
			JP 2002034942 A	05-02-2002

WO 0202169	A	10-01-2002	AU 3525801 A	14-01-2002
			CA 2414578 A1	10-01-2002
			CN 1440302 A	03-09-2003
			EP 1311315 A1	21-05-2003
			JP 2004500969 T	15-01-2004
			US 6349724 B1	26-02-2002

WO 2004095379	A	04-11-2004	AU 2004232865 A1	04-11-2004
			BR P10409658 A	18-04-2006
			CA 2522855 A1	04-11-2004
			EP 1616306 A1	18-01-2006
			MX PA05011377 A	30-01-2006

US 2002038392	A1	28-03-2002	NONE	

DE 10021783	A1	30-11-2000	AU 4561400 A	17-11-2000
			WO 0066207 A1	09-11-2000
			FR 2793145 A1	10-11-2000

US 5910776	A	08-06-1999	NONE	

EPO FORM P0459

For more details about this annex : see Official Journal of the European Patent Office, No. 12/82

REFERENCES CITED IN THE DESCRIPTION

This list of references cited by the applicant is for the reader's convenience only. It does not form part of the European patent document. Even though great care has been taken in compiling the references, errors or omissions cannot be excluded and the EPO disclaims all liability in this regard.

Patent documents cited in the description

- DE 10116650 A1 [0004]
- DE 19625410 A1 [0004]
- DE 19809952 A1 [0005]

专利名称(译)	多部分医疗系统		
公开(公告)号	EP1731089A1	公开(公告)日	2006-12-13
申请号	EP2006252952	申请日	2006-06-07
[标]申请(专利权)人(译)	德尔格医疗有限责任公司		
申请(专利权)人(译)	德尔格医疗AG & CO.KG		
当前申请(专利权)人(译)	德尔格医疗AG & CO.KG		
[标]发明人	SCHERMEIER OLAF ZIERMANN FRANK		
发明人	SCHERMEIER, OLAF ZIERMANN, FRANK		
IPC分类号	A61B5/00 A61M16/00		
CPC分类号	A61M16/08 A61B5/0402 A61B5/145 A61M2205/3569 A61M2205/3592 A61M2205/52 A61M2205/6054 A61M2230/04 A61M2230/205 A61M2230/50		
优先权	102005026562 2005-06-08 DE		
其他公开文献	EP1731089B1		
外部链接	Espacenet		

摘要(译)

多部件医疗系统技术领域本发明涉及一种多部件医疗系统，其包括至少两个可通过位置确定连接装置（410,411）连接的部件，其中至少一个部件（44）旨在保持靠近连接的患者并且在系统的未连接状态和至少一个部件（41）可以在未连接状态下被其他部件移除或替换，由此旨在保持靠近患者的部件（44）包含用于数据存储的装置（45），其中可以通过接口（46）写入或读出，接口（46）机械地集成到位置确定连接装置（410,411）中。

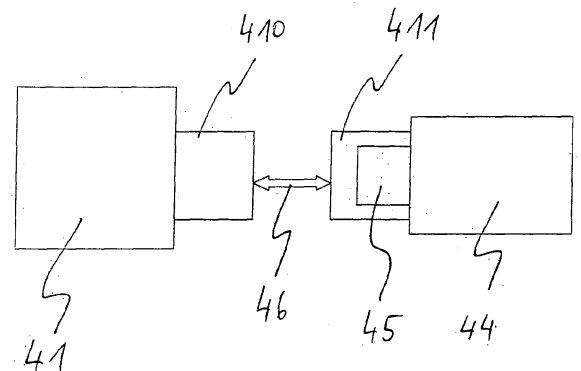

Fig. 4