



(12) **EUROPEAN PATENT APPLICATION**

(43) Date of publication:  
**10.05.2006 Bulletin 2006/19**

(51) Int Cl.:  
**H04L 1/24 (2006.01) A61B 5/00 (2006.01)**

(21) Application number: **05256807.8**

(22) Date of filing: **03.11.2005**

(84) Designated Contracting States:  
**AT BE BG CH CY CZ DE DK EE ES FI FR GB GR  
HU IE IS IT LI LT LU LV MC NL PL PT RO SE SI  
SK TR**  
Designated Extension States:  
**AL BA HR MK YU**

(72) Inventors:  
• **Anderson, Ralph**  
**Lexington, Massachusetts 02420-1313 (US)**  
• **Bernstein, Mike**  
**San Ramon, California 94583-1831 (US)**

(30) Priority: **03.11.2004 US 624670 P**

(74) Representative: **Vinsome, Rex Martin**  
**Urquhart-Dykes & Lord LLP**  
**St Nicholas Chambers,**  
**Amen Corner**  
**Newcastle upon Tyne, NE1 1PE (GB)**

(71) Applicant: **Draeger Medical Systems, Inc.**  
**Danvers, MA 01923 (US)**

(54) **A system for reducing signal interference in modulated signal communication**

(57) A system for reducing signal interference in modulated signal communication includes a measurement processor (120). The measurement processor measures amplitudes of noise components of a received amplitude modulated signal prior to demodulation. The measurement processor also identifies a frequency of a

noise component having an amplitude larger than the amplitude of another noise component. A carrier frequency generator (124) generates a carrier frequency substantially at a harmonic of the identified noise component. The carrier frequency is used to generate and demodulate the amplitude modulated signal.

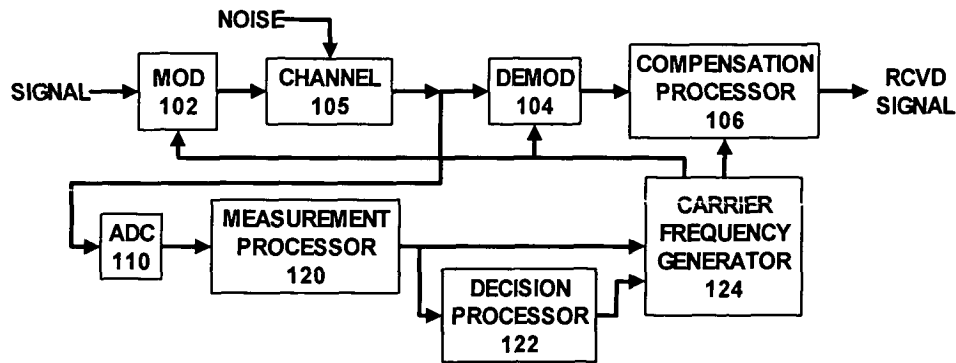

**Fig. 1**

**Description**

## CROSS-REFERENCED TO RELATED APPLICATION

**[0001]** This is a non-provisional application of U.S. Provisional Application Serial No. 60/624,670 filed November 3, 2004.

## FIELD OF THE INVENTION

**[0002]** The present application relates to a system for reducing signal interference in modulated signal communication, and in particular to a system for improving the performance of a patient medical monitoring system, such as a patient blood oxygen saturation parameter (SpO<sub>2</sub>) monitoring system, in the presence of signal interference.

## BACKGROUND OF THE INVENTION

**[0003]** Patient blood oxygen saturation parameter (SpO<sub>2</sub>) monitoring systems use light at different wavelengths transmitted through a blood-perfused portion of a patient e.g. a finger or ear lobe, to determine the oxygen saturation parameter of the patient. For example, light emitting diodes (LEDs), emitting light at the desired wavelengths, are arranged to be placed on one side of a patient finger and a photo-detector is arranged to be placed on the other side of the patient finger. The light from the LEDs is transmitted through the finger and detected by the photo-detector. The optical signals from the LEDs are modulated signals at a nominal predetermined carrier frequency. The electrical signal produced by the photo-detector, representing the received optical signal, is demodulated to produce signals representing estimates of the optical signals produced by the LEDs. These signals are processed in a known manner to calculate the oxygen saturation parameter for the patient.

**[0004]** There are several sources of noise interference which are introduced into the system. Electrical noise is introduced into the electrical portion of the SpO<sub>2</sub> system by other electrical equipment being operated in the vicinity of the SpO<sub>2</sub> system. Optical noise is introduced e.g. by the presence of ambient lighting in the patient room. It is to minimize the adverse affect of such noise that existing systems modulate the signal coupled to the LEDs at the carrier frequency. Subsequent processing involves subtracting adjacent samples, thus minimizing noise and reinforcing desired signals. Typically, however, the largest component of optical noise is introduced by ambient light detected by the photo-detector. Because the ambient light is generated by lights coupled to power mains, it has an AC component at the power mains frequency. This frequency is typically 50 or 60 Hz.

**[0005]** This AC noise component of the optical noise is demodulated. It is possible that harmonics of this interference signal are within the passband of the demodulated received signal and are eliminated or minimized

by subtraction. Some existing systems determine *a priori* expected frequencies of such harmonics, and pre-select a modulation frequency which is expected to minimize the adverse affects of these harmonics. However, such a system having a pre-selected modulation frequency set for one power mains frequency (e.g. 50Hz) is not optimum if used with another power mains frequency (e.g. 60Hz). Other existing systems attempt to detect the presence of such harmonic interference signals in the demodulated signal, and select one of a predetermined set of modulation frequencies which minimizes the adverse affects of the harmonics. This detection process is difficult and complicated, and it is possible that it does not always accurately identify a harmonic frequency. In either case, the frequency of the power mains, while generally at a nominally constant frequency, does vary. Such variation results in degrading the reduction of interference resulting from to the ambient noise.

## 20 BRIEF SUMMARY OF THE INVENTION

**[0006]** The inventors realized that if the modulating and demodulating carrier frequency is set to the frequency of a harmonic of the AC interference frequency in the expected passband of the modulated signal, then the harmonics are translated to zero frequency, that is to a DC component signal, in the demodulated signal. In this case, subtraction of a constant from the demodulated signal compensates for the interfering optical signal. To determine the frequencies of the harmonics in the passband, the frequency of the baseband AC interfering signal is determined from the received modulated signal before demodulation. The frequency of a harmonic in the passband of the modulated signal is calculated and the frequency of the carrier signal is locked to that frequency.

**[0007]** In accordance with principles of the present invention, a system for reducing signal interference in modulated signal communication includes a measurement processor. The measurement processor measures amplitudes of noise components of a received amplitude modulated signal prior to demodulation. The measurement processor also identifies a frequency of a noise component having an amplitude larger than the amplitude of another noise component. A carrier frequency generator generates a carrier frequency substantially at a harmonic of the identified noise component. The carrier frequency is used to generate and demodulate the amplitude modulated signal.

**[0008]** According to an aspect of the present invention, there is provided a system for reducing signal interference in modulated signal communication, comprising:

a measurement processor for,

measuring amplitudes of noise components of a received amplitude modulated signal prior to demodulation, and

identifying a frequency of a noise component having an amplitude larger than the amplitude of another noise component; and

a carrier frequency generator for generating a carrier frequency substantially at a harmonic of said identified noise component for use in generating and demodulating said amplitude modulated signal.

**[0009]** According to another aspect of the present invention, there is provided a method for reducing signal interference in modulated signal communication, comprising the activities of:

measuring amplitudes of noise components of a received amplitude modulated signal prior to demodulation;

identifying a frequency of a noise component having an amplitude larger than another noise component;

generating a carrier frequency substantially at a harmonic of said identified noise component; and

employing said generated carrier frequency substantially at said harmonic of said identified noise component in generating and demodulating said amplitude modulated signal.

**[0010]** According to a further aspect of the present invention, there is provided a tangible storage medium incorporating machine readable instructions for performing a method as defined above.

#### BRIEF DESCRIPTION OF THE DRAWING

**[0011]** In the drawing:

Fig. 1 is a block diagram of a system for reducing signal interference in modulated signal communication according to principles of the present invention;

Fig. 2 is a more detailed block diagram of the system illustrated in Fig. 1 according to principles of the present invention; and

Fig. 3 is a more detailed block diagram of another embodiment of the system illustrated in Fig. 1 according to principles of the present invention.

#### DETAILED DESCRIPTION OF THE INVENTION

**[0012]** A processor, as used herein, operates under the control of an executable application to (a) receive information from an input information device, (b) process the information by manipulating, analyzing, modifying, converting and/or transmitting the information, and/or (c) route the information to an output information device. For

example, it is possible for a processor to comprise the capabilities of a controller or microprocessor. It is further possible for the processor to operate with a display processor or generator. A display processor or generator is a known element for generating signals representing display images or portions thereof. A processor and a display processor comprises any combination of, hardware, firmware, and/or software.

**[0013]** An executable application, as used herein, comprises code or machine readable instructions for conditioning the processor to implement predetermined functions, such as those of an operating system, patient medical monitoring system such as a patient blood oxygen saturation parameter (SpO<sub>2</sub>) monitoring system, or other information processing system, for example, in response to user command or input. An executable procedure is a segment of code or machine readable instruction, sub-routine, or other distinct section of code or portion of an executable application for performing one or more particular processes. These processes include, among other things, receiving input data and/or parameters, performing operations on received input data and/or performing functions in response to received input parameters, and providing resulting output data and/or parameters.

**[0014]** Fig. 1 is a block diagram of a system for reducing signal interference in modulated signal communication according to principles of the present invention. In Fig. 1, a signal input terminal is coupled to a source (not shown) of a signal to be transmitted. The signal input terminal is coupled to a signal input terminal of a modulator 102. An output terminal of the modulator 102 generates a modulated signal which is supplied to a communication channel 105. A signal input terminal of a demodulator 104 is coupled to receive a signal from the channel 105. An output terminal of the demodulator 104 is coupled to a signal input terminal of a compensation processor 106. An output terminal of the compensation processor 106 is coupled to an output terminal producing a processed received signal. The output terminal is coupled to a signal processing unit (not shown) which processes the received signal.

**[0015]** An input terminal of an analog-to-digital converter (ADC) 110 is also coupled to receive the signal from the channel 105. An output terminal of the ADC 110 is coupled to a measurement processor 120. An output terminal of the measurement processor 120 is coupled to an input terminal of a decision processor 122, and a first input terminal of a carrier frequency generator 124. An output terminal of the decision processor 122 is coupled to a second input terminal of the carrier frequency generator 124. A carrier signal output terminal of the carrier frequency generator 124 is coupled to respective carrier input terminals of the modulator 102 and the demodulator 104. A control output terminal of the carrier frequency generator 124 is coupled to a control input terminal of the compensation processor 106.

**[0016]** In operation, the modulator 102 amplitude mod-

ulates a signal on a carrier signal supplied to the modulator 102 by the carrier frequency generator 124. The modulated signal is transmitted through the channel 105 to the demodulator 104. One or more noise components are introduced into the transmitted amplitude modulated signal in the channel 105, as described above. The demodulator 104 demodulates the received amplitude modulated signal, using the carrier signal supplied by the carrier frequency generator 124 as a local oscillator signal, to detect the signal modulated on the carrier.

**[0017]** The ADC 110 performs analog-to-digital conversion of the received signal, generating digital samples representing the received amplitude modulated signal, including the signal component and the noise components, prior to demodulation by the demodulator 104. The measurement processor 120 measures noise components by measuring at least one of: (a) amplitude, (b) frequency, (c) harmonic content, and (d) waveform morphology of the received amplitude modulated signal prior to demodulation. The frequency of a noise component having an amplitude larger than the amplitude of another noise component is identified. More specifically, in the illustrated embodiment, the frequency of a noise component having an amplitude larger than the respective amplitudes of the remaining noise components is identified. That is, the identified noise component frequency is the frequency of the noise component having: (a) substantially the largest amplitude noise component in the received amplitude modulated signal, and/or (b) substantially the largest, or equally largest, amplitude noise component in the received amplitude modulated signal.

**[0018]** The measurement processor 120 supplies data representing the noise component frequency identified as having the largest amplitude to the carrier frequency generator 124. The carrier frequency generator 124 generates a carrier signal substantially at a harmonic of the noise component identified by the measurement processor 120. This carrier signal is used by the modulator 102 and demodulator 104 in generating and demodulating the amplitude modulated signal. The measurement processor 120 and carrier frequency generator 124 operate continually, allowing the frequency of the carrier signal to track the identified frequency of the noise component having the largest amplitude.

**[0019]** It is expected that the frequency of the noise component having the largest amplitude is the frequency of the ambient light, i.e. the AC mains frequency (e.g. 50Hz or 60Hz). For example, the measurement processor 120 operates to identify 60Hz as the frequency of the noise component having the largest amplitude, to condition the carrier frequency generator 124 to generate a carrier signal at a harmonic of the 60Hz AC mains frequency, and to track variations in that frequency. If the expected passband of the amplitude modulated signal is from 500Hz to 700Hz, then the 9<sup>th</sup>, 10<sup>th</sup>, and 11<sup>th</sup> harmonics of 60Hz: i.e. 540Hz, 600Hz, and 660Hz, lie within the passband. In this case, the measurement processor 120 conditions the carrier frequency generator 124 to

generate a carrier frequency at one of the harmonics, e.g. the 10<sup>th</sup> harmonic, or 600Hz. Because the carrier frequency is set to and tracks one of these harmonics, e.g. the 10<sup>th</sup> harmonic, 600Hz, the frequency of these harmonics after demodulation by the demodulator 104 is 0Hz. This results in a DC component being associated with that noise component in the demodulated signal from the demodulator 104. The carrier frequency generator 124 supplies data representing the expected DC component to the compensation processor 106, which subtracts the expected DC component associated with that noise component from the demodulated signal, thereby minimizing the noise component having the largest amplitude.

**[0020]** The measurement processor 120 typically identifies the frequency of the AC mains as the noise component having the largest amplitude. However, it is possible that a different noise component, having a different fundamental frequency, has the largest amplitude. For example, electro-cautery equipment in operating rooms generate relatively large amounts of electronic interference, possibly having a larger amplitude than the optical interference from ambient lighting. The combination of the measurement processor 120 and carrier frequency generator 124 identifies the frequency of this noise component and generate a carrier signal which tracks the frequency of harmonics of this noise component within the passband of the demodulated signal.

**[0021]** It is possible for the carrier frequency to be determined in the following manner. The received modulated signal is filtered before demodulation to minimize the desired signal information representing the optical signals from the LEDs, and to pass primarily the noise components. The fundamental noise frequency is measured by any known means, such as use of a fast Fourier transform (FFT), or counting the number of clock cycles between two or more zero crossings of the filtered signal. Alternatively, if no optical signal from the LEDs is produced, the interfering noise components is able to be measured without requiring filtering of the signal information produced by the LEDs. In either case, the nominal carrier frequency is divided by the fundamental noise frequency and the result rounded to the nearest integer to determine the noise component harmonic to which the carrier frequency is locked. Following the example above, if the desired passband is from 500Hz to 700Hz, the nominal carrier frequency is 600Hz. The AC mains frequency is 60Hz. The quotient of 600 divided by 60 is 10. Thus, the 10<sup>th</sup> harmonic is selected to be the carrier frequency. A carrier frequency which tracks the 10<sup>th</sup> harmonic of the AC mains frequency (e.g. nominally 600Hz) is generated and used in generating and demodulating the amplitude modulated signal. This results in the noise component being transformed to DC when demodulated as described above.

**[0022]** Also as described above, the identification of the frequency of the noise component having the largest amplitude is done continually. The update rate depends

on the characteristics of the noise component and the desired performance of the system.

**[0023]** While typically, it is expected that a single noise component has the largest amplitude, it is possible for the measurement processor 120 to detect multiple noise components having substantially equal amplitudes larger than another noise component, or having the largest or equally largest amplitudes. In such a case, it is not possible to identify a frequency of a noise component having the largest amplitude. In response to identifying multiple noise components of substantially equal amplitude, the decision processor 122 inhibits the carrier frequency generator 124 from generating a carrier frequency substantially at a harmonic of an identified noise component. In this case the carrier frequency generator 124 is conditioned to generate a carrier signal at a nominal frequency (continuing the above example, at 600Hz). Alternatively the carrier frequency generator uses one of a plurality of known techniques, used by existing systems, to select a carrier frequency.

**[0024]** A system such as that described above is used in a patient medical parameter monitoring system, such as a patient blood oxygen saturation parameter (SpO<sub>2</sub>) monitoring system. Fig. 2 is a more detailed block diagram of the system illustrated in Fig. 1 according to principles of the present invention as embodied in an SpO<sub>2</sub> monitoring system. In Fig. 2, elements which are the same as those illustrated in Fig. 1 are designated by the same reference number and are not described in detail below.

**[0025]** In Fig. 2, an output terminal of a modulator 102 is coupled to an input terminal of an light-emitting-diode (LED) drive circuit 210. An output terminal of the LED drive circuit 210 is coupled to respective terminals of LED 3R and LED 3IR. LED 3R emits red light when activated and LED 3IR emits infrared (IR) light when activated. A photo-detector 5 is arranged to receive light signals from the LEDs 3R and 3IR. A blood-perfused portion of a patient 10, for example, a finger or ear lobe, is placed between the LEDs 3R and 3IR and the photo-detector sensor 5. This operates as the channel 105. The light generated by the LEDs 3R and 3IR is detected by the photo-detector device 5 following transmission through patient blood and tissue 10. An output terminal of the photo-detector sensor 5 is coupled to a series connection of an amplifier 202, a filter 204 and a buffer amplifier 206. An output terminal of the buffer amplifier 206 is coupled to a signal input terminal of a demodulator 214 and an input terminal of an ADC 110. A first output terminal of the demodulator 214 generates a signal representing the signal from the LED 3R and is coupled to a second ADC 220. A second output terminal of the demodulator 214 generates a signal representing the signal from LED 3IR and is coupled to a third ADC 226. The respective output terminals of the ADC 220 and ADC 226 are coupled to corresponding input terminals of a compensation processor 106. An output terminal of the compensation processor generates a processed received signal.

**[0026]** An output terminal of the ADC 110 is coupled to an input terminal of a measurement processor 120. An output terminal of the measurement processor 120 is coupled to respective input terminals of a decision processor 122 and a modulation processor 212. An output terminal of the modulation processor 212 is coupled to an input terminal of a carrier frequency generator 124. A carrier signal output terminal of the carrier frequency generator 124 is coupled to respective input terminals of the modulator 102 and the demodulator 214, and a control output terminal of the carrier frequency generator 124 is coupled to a control input terminal of the compensation processor 106. A control output terminal of the modulation processor 212 is coupled to respective control input terminals of the LED drive circuit 210 and the modulator 102.

**[0027]** In operation, the modulator 102 modulates the frequency from the carrier frequency generator 124 at the frequency of the noise component having the largest amplitude for transmission by the LEDs 3R and 3IR, as described above. The modulator 102 conditions the LED drive circuit 210 to drive the LEDs 3R and 3IR so as to produce an optical signal corresponding to the modulated carrier signal. The photo-detector sensor 5 detects an optical signal and provides an output voltage signal having a signal component representing the light generated by the LEDs 3R and 3IR and one or more noise components. The photo-detector sensor 5 output voltage signal is amplified by amplifier 202, filtered by filter 204 and buffered by buffer amplifier 206. One skilled in the art understands that it is possible to apply any or all of these signal processing functions and/or other similar signal processing functions to the photo-detector 5 output voltage signal to provide a signal having characteristics which are more easily processed by subsequent circuitry. One use for such processing is to reduce noise components which are more easily reduced before subsequent processing. For example, high frequency out-of-band noise is reduced by low-pass filtering.

**[0028]** The demodulator 214 demodulates the signal modulated on the noise component harmonic carrier frequency, received by the photo-detector sensor 5 and transmitted using the LEDs 3R and 3IR, to provide respective demodulated red and IR signals. These signals are converted to digital samples by the respective ADCs 220 and 226. The compensation processor 106 operates in a first mode of operation on the signal representing the optical signal transmitted by the red LED 3R and in a second mode of operation on the signal representing the optical signal transmitted by the IR LED 3IR. It is possible for the noise representative DC component for the signal representing the red LED 3R to be the same as or different from the noise representative DC component for the signal representing the IR LED 3IR. In the first and second operating modes, the compensation processor 106 operates to process the respective demodulated signals by subtracting the appropriate DC component, associated with the noise component having

the largest amplitude, from the corresponding demodulated LED signal (3R or 3IR). The compensation processor 6, thus, generates respective red and IR received signals in which that noise component is minimized. These signals are further processed in a known manner to calculate, display, record and/or transmit to another location the SpO<sub>2</sub> parameter.

**[0029]** The measurement processor 120 measures the amplitudes of the noise components of the received amplitude modulated signal prior to demodulation, and identifies the frequency of the noise component having an amplitude larger than another noise component, for example, the noise component having the largest amplitude. The identified frequency of this noise component is supplied to the modulation processor 212. The modulation processor 212 adjusts at least one of: (a) the modulation frequency, (b) the modulation drive pattern, and (c) type of modulation of the LEDs 3R and 3IR. More specifically, in the illustrated embodiment, the modulation processor 212 conditions the carrier frequency generator 124 to generate a carrier frequency signal for the LEDs 3R and 3IR substantially at a harmonic of the identified noise component signal. The generated carrier frequency signal substantially at the harmonic of the identified noise component is employed in generating and demodulating the amplitude modulated signal.

**[0030]** As described above, it is possible for the measurement processor 120 to measure the noise component more accurately by transmitting an unmodulated signal and measuring the noise components of the received unmodulated signal before demodulation. The LED drive circuit 210 is able to (a) change the amplitude of LED drive power, and/or (b) reduce to zero LED drive power, during the process of identifying and measuring noise components. The modulation processor 212 is able to condition the modulator 102 to employ one of a plurality of LED modulation drive patterns and/or to adjust the type of modulation provided to the LEDs 3R and 3IR. In addition, the modulation processor 212 is able to condition the LED drive circuit 210 to reduce the LED drive to zero to enable the measurement processor 120 to measure the noise components with no signal component present.

**[0031]** Also as described above, it is possible that multiple noise components have substantially equal amplitudes. In this case, the decision processor 122 inhibits the modulation processor 212 from conditioning the carrier frequency generator 124 to generate a carrier frequency substantially at a harmonic of an identified noise component. Instead, the modulation processor 212 is able to set the carrier frequency by one of the plurality of known methods, as described above. The modulation processor 212 is also able to control the amplitude of LED drive power, and the modulation drive pattern and type of modulation, for the LEDs 3R and 3IR when responding to the condition of having multiple noise components having substantially equal amplitudes.

**[0032]** The compensation processor 106, measure-

ment processor 120, decision processor 122, modulation processor 212 and carrier frequency generator 124 are illustrated as being embodied in a processor 250. In Fig. 2, the processor 250 has respective digital input terminals for receiving digital samples representing the demodulated red LED 3R representative signal, the demodulated IR LED 3IR representative signal and the signal representing the optical signal prior to demodulation. The processor 250 also has respective control output terminals for controlling the carrier frequency signal used by the modulator 102 and demodulator 214, the LED drive power generated by the LED drive circuit 210, and the modulation drive pattern and type of modulation produced by the modulator 102. The processor 250 also is illustrated as having respective output terminals producing noise reduced received red and IR representative signals. One skilled in the art understands the processor 250 is able to implement other functions. Among those other functions is processing the noise reduced red and IR signals to calculate, store, and/or transmit to another location, the SpO<sub>2</sub> parameter. It is further possible that the processor 250 cooperates with a display processor (not shown) to generate an image displaying the SpO<sub>2</sub> parameter for clinicians. These other functions are not germane to the present invention, and are not described in detail.

**[0033]** Fig. 3 is a more detailed block diagram of another embodiment of the system illustrated in Fig. 1 according to principles of the present invention. In Fig. 3, elements which are the same as those illustrated in Fig. 1 and Fig. 2 are designated by the same reference number and are not described in detail below. In Fig. 3, an output terminal of a crystal oscillator 362 is coupled to respective input terminals of a first clock generator 364 and a second clock generator 366. An output terminal of the first clock generator 364 is coupled to the modulator 102 and an output terminal of the second clock generator 366 is coupled to an input terminal of the demodulator 214. The modulator 102 is coupled to a parallel connection of a red LED 3R and an IR LED 3IR. The photodetector sensor 5 is illustrated as a photodiode. An output terminal of the photodiode 5 is coupled to a first input terminal of a multiplexer 354 and an input terminal of the demodulator 214. Respective first and second output terminals of the demodulator 214 are coupled to corresponding input terminals of the multiplexer 354. An output terminal of the multiplexer 354 is coupled to an input terminal of an ADC 356. An output terminal of the ADC 356 is coupled to an input terminal of the processor 350.

**[0034]** The processor has first and second control output terminals respectively coupled to the first clock generator 364 and the second clock generator 366. The processor 350 also has an output terminal for producing the noise reduced processed signal, either respective red and IR light representative signals, or a signal representing the SpO<sub>2</sub> parameter, or a signal representing an image displaying the SpO<sub>2</sub> parameter for reproduction on a display device (not shown). The processor 350 also

includes a bidirectional terminal coupled to tangible storage media 380.

**[0035]** In operation, the combination of the crystal oscillator 362 and the clock generator 364 produces a carrier signal for the modulator 102. For example, the crystal oscillator 362 is able to generate a relatively high frequency oscillatory signal. In one embodiment, the clock generator 364 includes a relatively high resolution controllable divider, controlled by a signal from the processor 350. The clock generator 364 is controlled by a signal produced by the executable application or executable procedure implementing the portion of the carrier frequency generator 124 which controls the frequency of the carrier frequency signal. This signal conditions the clock generator 364 to set a divide factor which divides the relatively high frequency signal from the crystal oscillator 362 by the appropriate amount to produce a carrier signal at the desired frequency. The combination of the crystal oscillator 362 and the clock generator 366 operates in the same manner to produce a carrier signal for the demodulator 214, and is typically controlled to produce a clock signal at the same frequency as the clock signal generated by the clock generator 364 for the modulator 102.

**[0036]** The red LED 3R is coupled in parallel with, but opposed to, the IR LED 3IR. In response to positive cycles of the modulation signal from the modulator 102, the IR LED 3IR produces an optical signal, and in response to negative cycles of the modulation signal from the modulator 102, the red LED 3R produces an optical signal. As described above, these optical signals are transmitted through patient blood and tissue 10 and are detected by the photodiode 5. The ADC 356 is a relatively high speed ADC which is capable of performing the analog-to-digital conversion of the received signal from the photodiode 5, the received red LED 3R signal, and the received IR LED 3IR signal. The multiplexer 354 couples a signal at one of the input terminals to the ADC 356 at a time and the ADC 356 produces a digital sample representing that signal.

**[0037]** The processor 350 includes an executable application, and possibly respective executable procedures, which perform the functions of the measurement processor 120, the decision processor 122, the modulation processor 212, the compensation processor 106 and at least a portion of the carrier frequency generator, i.e. the portion of the carrier frequency generator 124 which controls the frequency of the carrier frequency signal generated (Fig. 1 and Fig. 2). As the processor 350 receives digital samples from the ADC 356, they are routed to the appropriate executable procedure. For example, samples representing the signal from the photodiode 5 before demodulation are routed to the executable procedure implementing the operations of the measurement processor 120. Samples representing the received demodulated red and IR LED (3R, 3IR) signals are routed to the executable procedure implementing the operations of the compensation processor 106. Similarly, the exe-

cutable procedures condition the processor 350 to generate appropriate control signals. For example, the executable procedure implementing the portion of the carrier frequency generator 124 which controls the frequency of the carrier frequency signal generated conditions the processor 350 to produce the control signal supplied to the first and second clock signal generators 364 and 366. These signals condition the first and second clock signal generators 364 and 366 to produce respective carrier signals at the desired frequency as described above.

**[0038]** The processor 350 is bidirectionally coupled to the tangible storage media 380. The tangible electronic data storage media 380 includes magnetic devices such as reel-to-reel computer tape, cassette tapes, and magnetic disk media such as floppy disks, and so forth. The tangible electronic data storage media 380 also includes optical devices, such as digital video disks (DVD) or compact disks (CD) and so forth. The tangible electronic data storage media 380 also includes portable storage devices such as semiconductor memory integrated circuits and so forth. The tangible storage media 380 is capable of storing any data. More specifically, in the illustrated embodiment, the machine readable instructions forming the executable application and/or executable procedures for performing the activities in the system described above are stored in a tangible storage medium 380. The processor 350 retrieves the machine readable instructions for performing the activities of the executable application and/or executable procedures from the appropriate tangible electronic data storage medium 380, and stores them in the memory (not shown) included in the processor 350. The processor 350 then executes the executable application and/or executable procedures stored in the memory to perform the activities described above.

**[0039]** The system is illustrated in Fig. 3 to include only those elements necessary to understand the operation of such a system using a processor executing an executable application and respective executable procedures to perform the activities of elements illustrated in Fig. 1 and Fig. 2. One skilled in the art understands that the processor 350 includes executable procedures to implement other functions, e.g. to calculate the value of the SpO<sub>2</sub> parameter and generate image representative signals for conditioning a display device to display the SpO<sub>2</sub> parameter. It is also possible for the system illustrated in Fig. 3 to include other circuitry illustrated in Fig. 2, including the LED drive circuit 210, amplifier 202, filter 204, and buffer amplifier 206.

**[0040]** One skilled in the art understands that it is possible to modulate the red LED 3R and IR LED 3IR at different modulation frequencies in order to reject different noise components for the red and IR optical channels, respectively. One skilled in the art also understands that the processing functions described above with respect to Fig. 1, Fig. 2 and/or Fig. 3 are able to be performed in hardware, software or a combination of both.

**[0041]** It will be appreciated by persons skilled in the

art that the above embodiments have been described by way of example only and not in any limitative sense, and that various alterations and modifications are possible without departure from the scope of the invention as defined by the appended claims.

## Claims

1. A system for reducing signal interference in modulated signal communication, comprising:
  - a measurement processor for, measuring amplitudes of noise components of a received amplitude modulated signal prior to demodulation, and identifying a frequency of a noise component having an amplitude larger than the amplitude of another noise component; and
  - a carrier frequency generator for generating a carrier frequency substantially at a harmonic of said identified noise component for use in generating and demodulating said amplitude modulated signal.
2. A system according to claim 1, further comprising:
  - a demodulator for demodulating a received signal modulated at said noise component harmonic carrier frequency to provide a demodulated signal; and
  - a compensation processor for processing said demodulated signal and subtracting a DC component associated with said noise component from said processed demodulated signal.
3. A system according to claim 1 or 2, further comprising an analog-to-digital converter (ADC) for analog-to-digital conversion of said received signal modulated at said noise component harmonic carrier frequency prior to demodulation.
4. A system according to any one of the preceding claims, wherein said measurement processor measures said received amplitude modulated signal and identifies noise components by at least one of: (a) amplitude, (b) frequency, (c) harmonic content, and (d) waveform morphology.
5. A system according to any one of the preceding claims, wherein said identified noise component frequency is of a noise component being at least one of: (a) substantially the largest amplitude noise component in said received amplitude modulated signal, and (b) substantially the largest, or equally largest, amplitude noise component in said received amplitude modulated signal.
6. A system according to any one of the preceding claims, wherein said measurement processor identifies multiple noise components of substantially equal amplitude, said substantially equal amplitude being larger than another noise component.
7. A system according to claim 6, wherein said multiple noise components being substantially the largest, or equally largest, amplitude noise components in said received amplitude modulated signal.
8. A system according to claim 6 or 7, further comprising a decision processor for inhibiting said carrier frequency generator from generating a carrier frequency substantially at said harmonic of said identified noise component, in response to said identification of multiple noise components of substantially equal amplitude.
9. A system according to any one of the preceding claims, wherein said modulated signal communication is for patient medical parameter monitoring.
10. A system according to any one of the preceding claims, further comprising:
  - a light emitting diode (LED);
  - a photo-detector sensor for providing an output voltage signal in response to light generated by said LED;
  - a modulator for modulating a carrier frequency at said noise component harmonic for transmission using said LED; and
  - a demodulator for demodulating a signal modulated on said noise component harmonic carrier frequency received by said photo-detector sensor and transmitted using said LED, to provide a demodulated signal.
11. A system according to claim 10, further comprising an LED drive unit for at least one of: (a) changing the amplitude of LED drive power, and (b) reducing to zero LED drive power, during identifying and measuring noise components.
12. A system according to claim 10 or 11, further comprising a modulation processor that adjusts at least one of: (a) modulation frequency, (b) modulation drive pattern, and (c) type of modulation of said LED.
13. A system according to any one of claims 10 to 12, further comprising a modulation processor that adjusts LED modulation frequency to substantially match the frequency of a harmonic of the identified noise component signal.
14. A system according to any one of claims 10 to 13, further comprising a compensation processor for

processing said demodulated signal and subtracting a DC component associated with said noise component from said processed demodulated signal.

15. A system according to any one of claims 10 to 14, wherein said sensor output voltage signal is provided by at least one of: (a) amplification, (b) filtering, and (c) buffering of a signal provided by a photo-detector device. 5  
10
16. A system according to any one of claims 10 to 15, wherein said system is for patient blood oxygen saturation parameter monitoring. 10
17. A system according to any one of claims 10 to 16, wherein said light generated by said LED is detected by said photo-detector device following transmission through patient blood and tissue. 15
18. A system according to any one of claims 10 to 17, wherein said LED comprises a red and an infra-red LED and said system performs measurements and compensation of sensor output voltage in a first mode in response to light provided by said red LED and in a second mode in response to light provided by said infra-red LED. 20  
25
19. A method for reducing signal interference in modulated signal communication, comprising the activities of: 30  
measuring amplitudes of noise components of a received amplitude modulated signal prior to demodulation; 35  
identifying a frequency of a noise component having an amplitude larger than another noise component; 35  
generating a carrier frequency substantially at a harmonic of said identified noise component; 40  
and 40  
employing said generated carrier frequency substantially at said harmonic of said identified noise component in generating and demodulating said amplitude modulated signal. 45
20. A tangible storage medium incorporating machine readable instructions for performing the activities of claim 19. 50  
55

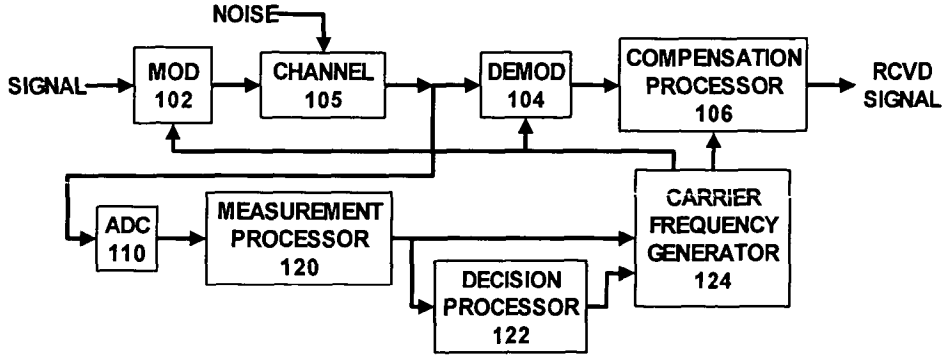

Fig. 1

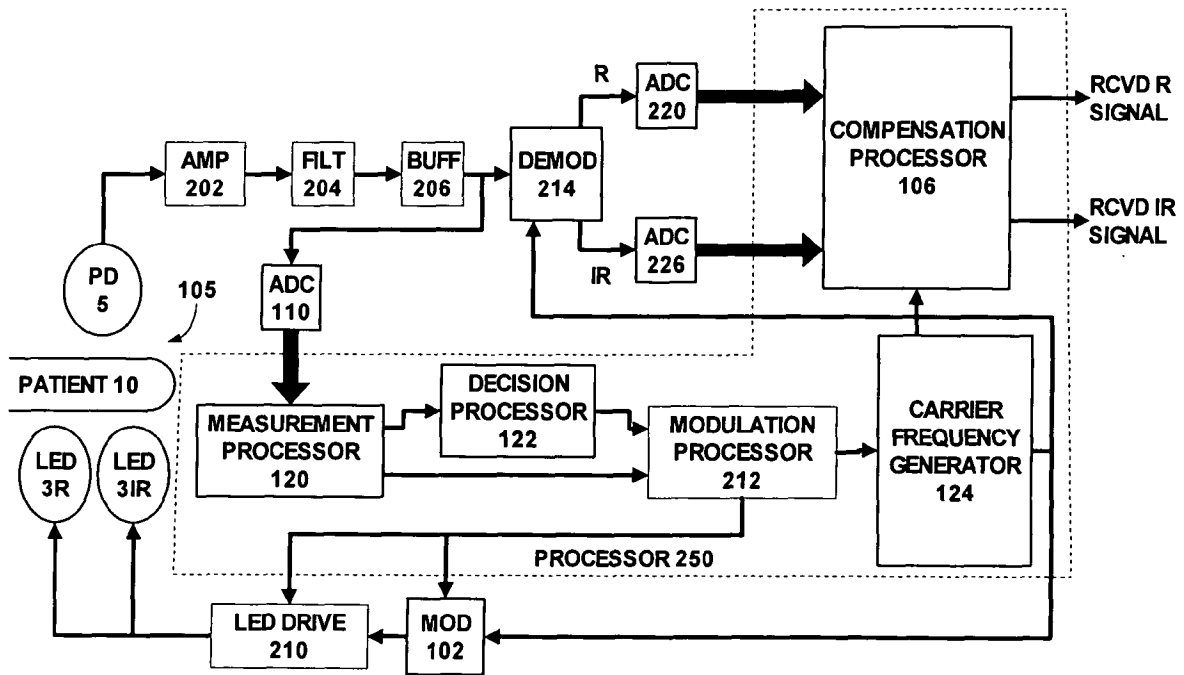

Fig. 2

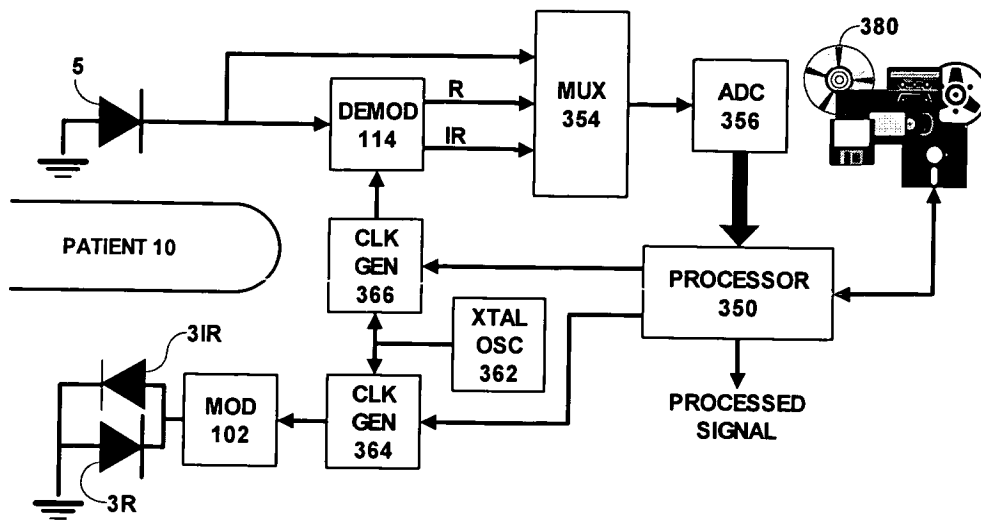

Fig. 3



DOCUMENTS CONSIDERED TO BE RELEVANT			
Category	Citation of document with indication, where appropriate, of relevant passages	Relevant to claim	CLASSIFICATION OF THE APPLICATION (IPC)
X	EP 1 453 211 A (NTT DOCOMO, INC) 1 September 2004 (2004-09-01) * paragraphs [0025], [0030], [0045], [0049], [0103] *	1,2,4,5, 9,19,20	H04L1/24 A61B5/00
A	EP 0 502 717 A (SENSORMEDICS CORPORATION) 9 September 1992 (1992-09-09) * page 3, line 11 - line 14 * * page 4, line 38 - line 48 *	1,10-20	
A	US 4 843 339 A (BURT ET AL) 27 June 1989 (1989-06-27) * column 11, line 44 - column 12, line 25 *	1,19,20	
			TECHNICAL FIELDS SEARCHED (IPC)
			H04L A61B H04B
The present search report has been drawn up for all claims			
Place of search The Hague		Date of completion of the search 2 February 2006	Examiner Knüpling, M
CATEGORY OF CITED DOCUMENTS		T : theory or principle underlying the invention E : earlier patent document, but published on, or after the filing date D : document cited in the application L : document cited for other reasons ..... & : member of the same patent family, corresponding document	
X : particularly relevant if taken alone Y : particularly relevant if combined with another document of the same category A : technological background O : non-written disclosure P : intermediate document			

1  
EPO FORM 1503 03.02 (P04C01)

**ANNEX TO THE EUROPEAN SEARCH REPORT  
ON EUROPEAN PATENT APPLICATION NO.**

EP 05 25 6807

This annex lists the patent family members relating to the patent documents cited in the above-mentioned European search report. The members are as contained in the European Patent Office EDP file on  
The European Patent Office is in no way liable for these particulars which are merely given for the purpose of information.

02-02-2006

Patent document cited in search report	Publication date	Patent family member(s)	Publication date
EP 1453211 A	01-09-2004	CN 1525654 A	01-09-2004
		US 2004171352 A1	02-09-2004
-----			
EP 0502717 A	09-09-1992	CA 2062270 A1	06-09-1992
		DE 69220520 D1	31-07-1997
		US 5349952 A	27-09-1994
-----			
US 4843339 A	27-06-1989	DE 3836805 A1	11-05-1989
		FR 2622751 A1	05-05-1989
		GB 2211687 A	05-07-1989
		JP 1129607 A	22-05-1989
		JP 7060979 B	28-06-1995
-----			

专利名称(译)	一种用于减少调制信号通信中的信号干扰的系统		
公开(公告)号	<a href="#">EP1655881A1</a>	公开(公告)日	2006-05-10
申请号	EP2005256807	申请日	2005-11-03
[标]申请(专利权)人(译)	德雷格医疗系统股份有限公司		
申请(专利权)人(译)	德尔格医疗系统公司.		
当前申请(专利权)人(译)	德尔格医疗系统公司.		
[标]发明人	ANDERSON RALPH BERNSTEIN MIKE		
发明人	ANDERSON, RALPH BERNSTEIN, MIKE		
IPC分类号	H04L1/24 A61B5/00		
CPC分类号	G01N21/35 A61B5/14551 G01N2021/3144 G01N2021/3181 H04N5/21		
优先权	60/624670 2004-11-03 US		
其他公开文献	EP1655881B1		
外部链接	<a href="#">Espacenet</a>		

摘要(译)

用于减少调制信号通信中的信号干扰的系统包括测量处理器 ( 120 )。测量处理器在解调之前测量接收的调幅信号的噪声分量的幅度。测量处理器还识别具有大于另一噪声分量的幅度的幅度的噪声分量的频率。载波频率发生器 ( 124 ) 基本上在所识别的噪声分量的谐波处产生载波频率。载波频率用于产生和解调幅度调制信号。

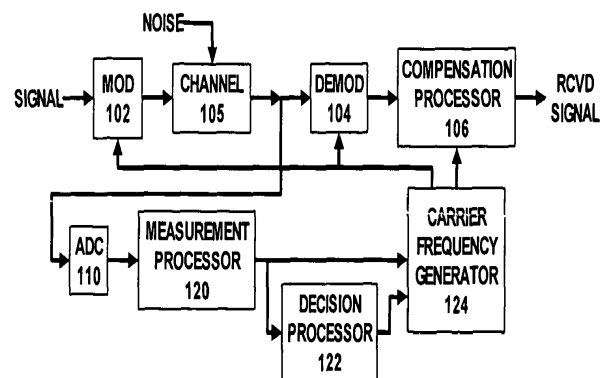

Fig. 1