

(19) World Intellectual Property Organization
International Bureau



(43) International Publication Date
29 July 2010 (29.07.2010)

PCT

(10) International Publication Number
WO 2010/085329 A1

(51) International Patent Classification:

A61B 18/18 (2006.01) A61B 5/00 (2006.01)
A61B 5/06 (2006.01) A61B 17/00 (2006.01)
G01K 11/00 (2006.01) A61B 18/14 (2006.01)

(21) International Application Number:

PCT/US2010/000129

(22) International Filing Date:

20 January 2010 (20.01.2010)

(25) Filing Language:

English

(26) Publication Language:

English

(30) Priority Data:

12/356,205 20 January 2009 (20.01.2009) US

(71) Applicant (for all designated States except US):

MERIDIAN MEDICAL SYSTEMS, LLC [US/US]; 77
Goose Cove Lane, Woolwich, ME 04579 (US).

(72) Inventors; and

(75) Inventors/Applicants (for US only): CARR, Kenneth,

L. [US/US]; 77 Goose Cove Lane, Woolwich, ME 04579
(US). ALLISON, Robert, C. [US/US]; 6910 Larkvale
Avenue, Rancho Palos Verdes, CA 90275 (US).

(74) Agents: MCKENNA, John, F. et al.; Cesari And Mcken-

na, LLP, 88 Black Falcon Avenue, Boston, MA 02210
(US).

(81) Designated States (unless otherwise indicated, for every

kind of national protection available): AE, AG, AL, AM,
AO, AT, AU, AZ, BA, BB, BG, BH, BR, BW, BY, BZ,
CA, CH, CL, CN, CO, CR, CU, CZ, DE, DK, DM, DO,
DZ, EC, EE, EG, ES, FI, GB, GD, GE, GH, GM, GT,
HN, HR, HU, ID, IL, IN, IS, JP, KE, KG, KM, KN, KP,
KR, KZ, LA, LC, LK, LR, LS, LT, LU, LY, MA, MD,
ME, MG, MK, MN, MW, MX, MY, MZ, NA, NG, NI,
NO, NZ, OM, PE, PG, PH, PL, PT, RO, RS, RU, SC, SD,
SE, SG, SK, SL, SM, ST, SV, SY, TH, TJ, TM, TN, TR,
TT, TZ, UA, UG, US, UZ, VC, VN, ZA, ZM, ZW.

(84) Designated States (unless otherwise indicated, for every

kind of regional protection available): ARIPO (BW, GH,
GM, KE, LS, MW, MZ, NA, SD, SL, SZ, TZ, UG, ZM,
ZW), Eurasian (AM, AZ, BY, KG, KZ, MD, RU, TJ,
TM), European (AT, BE, BG, CH, CY, CZ, DE, DK, EE,
ES, FI, FR, GB, GR, HR, HU, IE, IS, IT, LT, LU, LV,
MC, MK, MT, NL, NO, PL, PT, RO, SE, SI, SK, SM,
TR), OAPI (BF, BJ, CF, CG, CI, CM, GA, GN, GQ, GW,
ML, MR, NE, SN, TD, TG).

Published:

— with international search report (Art. 21(3))

(54) Title: METHOD AND APPARATUS FOR ALIGNING AN ABLATION CATHETER AND A TEMPERATURE PROBE FOR AN ABLATION PROCEDURE

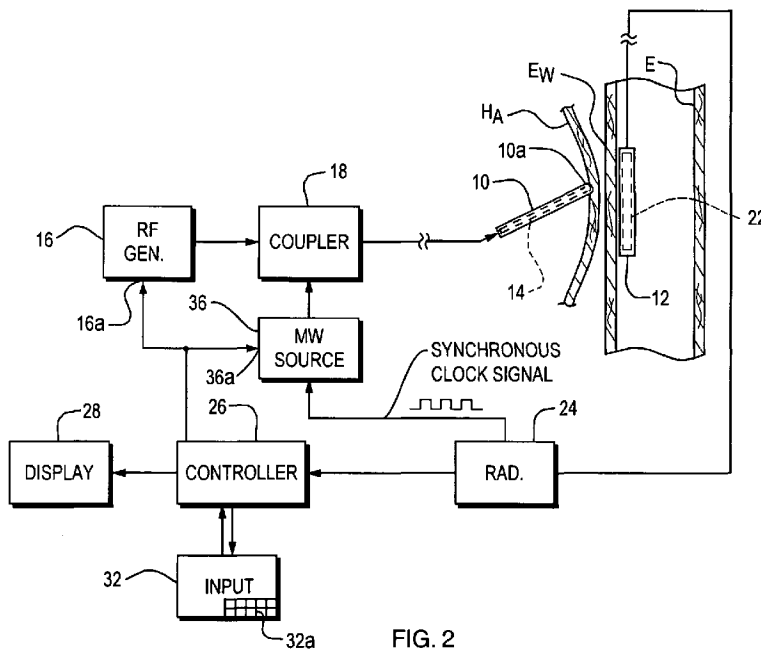

FIG. 2

(57) Abstract: Apparatus for aligning an ablation catheter and a temperature probe relatively for an ablation procedure includes an ablation catheter with a first antenna for ablating tissue at an ablation site in a patient's body and a temperature probe for placement in a body passage having a wall portion adjacent to the ablation site so that a second antenna in the probe is positioned opposite the first antenna. A microwave source provides a pulse modulated microwave signal to one of the antennas and a radiometer is in circuit with the other antenna. A synchronizing device in circuit with the microwave source and the radiometer enables the radiometer to synchronously detect the microwave signal so that the radiometer provides an alignment signal whose strength reflects the degree of alignment of the first and second antennas which signal may be used to control an alignment display. An alignment method using the apparatus is also disclosed.

WO 2010/085329 A1

METHOD AND APPARATUS FOR ALIGNING AN ABLATION CATHETER AND A TEMPERATURE PROBE FOR AN ABLATION PROCEDURE

BACKGROUND OF THE INVENTION

This invention relates generally to the treatment of certain diseases by tissue ablation wherein electromagnetic energy from an antenna in an ablation catheter heats tissue sufficiently to cause necrosis and a separate temperature sensing antenna in a temperature probe placed in a body passage or cavity adjacent to the ablation site
5 measures tissue temperature to enable the operating surgeon to avoid overheating tissue during the ablation procedure. It relates especially to method and apparatus enabling the surgeon to align the two antennas to optimize that temperature measurement.

In a typical cardiac ablation procedure, an antenna catheter is used to resistively
10 heat heart tissue, usually at the left side of the heart, sufficiently to intentionally damage the target tissue in order to cure a potentially fatal heart arrhythmia. Typically, heating the tissue to a temperature in excess of 70°C for 30-60 seconds is sufficient to cause tissue necrosis. During treatment, electromagnetic energy, usually in the RF frequency range, is applied between the tip of the antenna catheter and a ground plate removably
15 affixed to the patient's back, creating an electrical circuit. The point of highest resistance in this circuit, normally the interface between the catheter tip and the heart tissue, is the region which heats the most and thus may cause intentional, irreversible damage to the heart tissue to correct the arrhythmia.

Anatomically, the esophagus is very close to, and may even contact, part of the
20 left atrium. Indeed, the average distance between the endocardial surface of the left atrium and the anterior surface of the esophagus is only in the order of 4.4 +/- 1.2 mm. Thus, ablating certain regions of the left atrium to treat various arrhythmias in the heart can unintentionally cause thermal damage to the esophagus, often with severe consequences.

25 In order to prevent such overheating, a temperature probe may be positioned in the patient's esophagus adjacent to the ablation site in the heart. One conventional temperature probe carries conventional point source temperature sensors such as

thermocouples, thermistors or the like to monitor, and ultimately prevent the overheating of, the esophagus wall by cutting off or reducing the power delivered to the ablation catheter; see, e.g., US2007/0066968.

Another type of temperature probe developed only recently is disclosed in
5 Provisional Application No. 61/145,800, filed on January 20, 2009, the entire contents of which are hereby incorporated herein by reference. That probe incorporates a microwave antenna which is connected to an external receiver in the form of a radiometer. The radiometer detects the thermal emissions picked up by the antenna in the probe which reflect the temperature of the tissue being examined and produces corresponding
10 temperature signals to control a display which displays that temperature. During ablation, that apparatus can measure the temperature at depth in the esophageal tissue which is in close proximity to the ablation site in the patient's heart. That measurement can then be used to prevent unintentional thermal damage to the esophagus or other body passage.

15 As described in the above provisional application, a temperature probe using microwave radiometry provides definite advantages in that it can measure temperature at depth in the passage wall to avoid thermal damage thereto enabling the operating surgeon to adjust the power to the ablation catheter as needed to provide sufficient heating of the heart tissue to cause necrosis, but not enough to result in surface charring of that tissue
20 that could cause a stroke and/or the formation of microbubbles (popping) that could rupture the heart vessel wall. Also, such radiometric sensing allows accurate measurement of tissue temperature even when cooling is being provided.

However, in order to optimize the accuracy of the temperature measurement provided by the temperature probe, it is desirable that the antenna therein be aligned
25 properly with the antenna in the ablation catheter. Until now, there has been no means in the prior apparatus of this type to enable the operating surgeon to verify that the two antennas are indeed in alignment. Resultantly, in some instances, the temperature measurements may not be accurate enough to avoid thermal damage to tissue and in others, the ablation procedure may take too long because of tissue underheating.

SUMMARY OF THE INVENTION

Accordingly, an object of the present invention is to provide a method for properly aligning the antenna in an ablation catheter positioned at an ablation site in a human or animal body and the antenna in a temperature probe located in a body passage adjacent to the ablation site.

Another object is to provide such a method which can be employed even when the ablation site and/or passage are/is being cooled.

A further object is to provide apparatus for implementing the above method.

Still another object is to provide such apparatus wherein the antenna in the temperature probe may be either directional or omni-directional.

Other objects will, in part, be obvious and will, in part, appear hereinafter.

The invention accordingly comprises the several steps and the relation of one or more of such steps with respect to each of the others, and the apparatus embodying the features of construction, combination of elements and arrangement of parts which are adapted to effect such steps, all as exemplified in the following detailed description, and the scope of the invention will be indicated in the claims.

In apparatus of the type with which this invention is concerned, an ablation catheter containing a first antenna is positioned at an ablation site in a patient's body and a temperature probe containing a second antenna is placed in a body passage having a wall portion adjacent to the ablation site so that the probe is more or less opposite the ablation site. An electromagnetic signal of a first frequency may be delivered by an external generator to the first antenna to ablate tissue at the ablation site, while the second antenna picks up thermal emissions from said wall portion and provides a signal which may be detected and used to control a display so that the display indicates the temperature of that wall portion. By viewing the display, an operating surgeon can appropriately control the generator to avoid overheating the wall tissue.

In accordance with this invention, an antenna alignment circuit is connected between the two antennas. The alignment circuit includes a microwave source which transmits from one antenna to the other a modulated microwave signal of a second frequency different from the first frequency. That microwave signal is picked up by the other, receiving, antenna connected to a radiometer. The radiometer detects the

microwave signal and produces an alignment signal whose strength is indicative of the degree of alignment of the first and second antennas. That is, the alignment signal is strongest when the two antennas are directly opposite one another. The alignment signal may be used to control a display enabling an operating surgeon to see exactly when the alignment signal strength is at a maximum signifying that the two antennas are in optimum alignment.

As we shall see, the microwave communication between the two antennas can be implemented in either direction to properly position the two antennas relatively both axially and in azimuth. The invention thus allows optimal delivery of ablation power to the antenna in the ablation catheter while preventing unwanted surface charring of the tissue being ablated and thermal damage to the passage wall adjacent to the ablation site. It will also allow the ablation procedure to be carried out in a minimum length of time.

Using this method, by observing the alignment display, a surgeon may determine in real time the relative position of an ablation catheter and a temperature probe and adjust one or the other to obtain the strongest alignment signal before the ablation procedure has commenced. Then, during the actual ablation when the RF energy from the ablation catheter starts to heat beyond the tissue intended to be heated and/or inadvertently starts to heat the wall of the adjacent body passage, e.g. the esophagus, there will be a noticeable temperature rise signaled by the temperature probe so that the apparatus' temperature display will provide the surgeon with a clear, early warning of potential tissue damage.

While we will describe the invention in a cardiac ablation context, the same antenna alignment technique may be used in connection with other procedures wherein tissue ablation is performed adjacent to a natural passage in the body, such as the treatment of benign prostatic hyperplasia (BPH) wherein an ablation catheter is positioned in the patient's urethra and a temperature probe is located in the rectal cavity.

BRIEF DESCRIPTION OF THE DRAWINGS

For a fuller understanding of the nature and objects of the invention, reference should be made to the following detailed description taken in connection with the accompanying drawings, in which:

FIG. 1 is a diagrammatic view of a patient's head and torso showing an ablation catheter in the left atrium of the heart and a temperature probe situated in the esophagus adjacent to the catheter;

FIG. 2 is a block diagram of apparatus for aligning an ablation catheter and a
5 temperature probe according to this invention;

FIGS. 3A to 3C are diagrammatic views showing different versions of the coupler portion of the FIG. 2 apparatus, and

FIG. 4 is a diagram similar to FIG. 2 of a second embodiment of the invention.

DESCRIPTION OF THE PREFERRED EMBODIMENTS

10 Refer first to FIG. 1 of the drawings which shows the head and torso of a patient having a heart H with a left ventricle H_V and a left atrium H_A . As is usually the case, the left atrium of the heart is very close to the anterior wall of the patient's esophagus E. During a conventional cardiac ablation procedure, an ablation catheter 10 is threaded into the left atrium H_A via left ventricle H_V so that the working end 10a of the catheter
15 contacts the posterior wall of the left atrium as shown in FIG. 1.

In order to prevent overheating of the esophagus E during such an ablation procedure, a temperature probe 12 may be inserted into the patient's nasal passage N and threaded down into the esophagus E via the patient's pharynx P until the probe is positioned directly opposite the catheter end 10a at the ablation site as shown in FIG. 1.
20 As the heart tissue is being ablated by catheter 10, the temperature probe 12 picks up thermal emissions from the esophageal wall E_w and corresponding temperature signals are produced which may be used to prevent overheating of the esophagus as described in detail in the above provisional application.

Referring to FIG. 2, catheter 10 includes an ablation antenna 14 which receives an
25 RF signal from an RF generator 16. Preferably, antenna 14 is of the type disclosed in US2007/0299488, the contents of which are hereby incorporated herein by reference and it is matched to a selected first frequency, e.g. 550 KHz. However, instead of receiving this signal from the generator directly, the antenna receives it by way of a microwave coupler 18 which is part of an alignment circuit to be described in detail shortly.

The temperature probe 12 contains an antenna 22 for picking up thermal emissions from the wall portion E_w . Preferably, the antenna is of the type described in US2007/0219548, the contents of which are hereby incorporated herein by reference. Antenna 22 is connected to the input of a radiometer 24 which detects the signal from antenna 22 and produces a corresponding temperature signal. Preferably, the radiometer operates at a center frequency corresponding to said second frequency, i.e. 4.0 GHz, so that the apparatus can detect thermal emissions from relatively deep regions of the esophageal wall E_w .

The temperature signal from the radiometer is routed to a controller 26 which produces a corresponding control signal for controlling a display 28 which can display the temperature of the tissue being examined by the probe 12. Preferably the display indicates esophageal tissue temperature as a function of time so that the surgeon can see that temperature in real time. Of course, the display 28 may also display other parameters relating to proper operation of the apparatus.

The controller 26 may receive instructions via the control buttons 32a of an operator-controlled input keyboard 32.

As described in the above provisional application, the temperature signal from controller 26 may also be coupled to a control input terminal 16a of the generator 16 to control the power being delivered to the ablation catheter 10 and the apparatus may include means for cooling the tissue at the ablation site and/or the esophagus.

Still referring to FIG. 2, the alignment circuit mentioned above is provided in order to assure that the antenna 22 in probe 12 is aligned with the antenna 14 in catheter 10 when the ablation procedure is carried out to allow optimal delivery of ablation power to the antenna 14 with minimal likelihood of unwanted thermal damage to the heart and/or to the esophageal wall E_w during the ablation procedure.

The alignment circuit comprises, in addition to the coupler 18, a microwave source 36 controlled by a clock signal from radiometer 24 so that the radiometer and source 36 operate in synchronism. The source 36 provides a signal of a second frequency different from the first, e.g. 4.0 GHz, which is pulse modulated. This microwave signal from source 36 is coupled to, and transmitted by, antenna 14, picked up by antenna 22 and detected by radiometer 24. Modulation of the transmitted waveform allows detection

by the radiometer 24 of very low levels of microwave signal in the presence of high levels of interfering noise. Thus, the AM pulse modulated microwave signal from antenna 14 can easily be recognized and detected by the sensitive radiometer 24 and the strength of this signal is directly related to the degree of alignment of the two antennas.

5 In response to the detected signal, the radiometer delivers an alignment signal via controller 26 to display 28 which thereupon provides an indication of that signal strength as a function of time.

Preferably, the two antennas 14 and 22 are aligned prior to the actual ablation procedure. For this, the controller 26 may be instructed via terminal 32 or a hand control
10 (not shown) on catheter 10 to apply a control signal C to the control terminal 16a of generator 16 that turns off or reduces the RF power output from the generator for a selected time or until the operator determines from the display 28 that the antennas are aligned following which the signal C from the controller may cause the generator to operate at full power sufficient to ablate tissue. That same control signal C is applied to a
15 control terminal 36c of source 36 to deactivate that source so that the generator and source are active alternatively.

The antenna 22 in temperature probe 12 may be omni-directional, but is more preferably a directional antenna of the type described in the above US2007/0299488. Such a directional antenna provides a better temperature measurement resolution in the
20 direction of the catheter 10. That is, with a directional antenna, the tissue at wall portion E_w represents a more significant portion of the antenna pattern of antenna 12, which will significantly improve the temperature measurement resolution.

The microwave coupler 18 in the FIG. 2 apparatus may have different forms. Preferably, it is located near the proximal end of catheter 10 and near the generator 16.
25 The coupler is basically a diplexer or T/R switch which couples the microwave signal from source 36 to antenna 14. A capacitive coupling method is preferred, with a directional capacitive coupling approach being the optimum. This approach directs the microwave energy from source 36 toward the antenna 14 and away from the RF generator 16. The modulated microwave signal propagates out to the tip of antenna 14
30 where it radiates into the heart tissue.

In the coupler 18 depicted in FIG. 3A, the signal from microwave source 36 is capacitively coupled at 42 to the line from RF generator 16 to antenna 14 with an upstream filter 44 being provided which passes the RF signal but isolates generator 16 from the microwave signal.

5 In FIG. 3B, the coupler 18 comprises a transmission line 46 connected between generator 16 and antenna 14, with a branch 46a receiving the output signal from source 36 by way of a DC blocking capacitor 48.

In FIG. 3C, the coupler 18 comprises a conventional ferrite circulator 52 connected between generator 16 and antenna 14 and designed to operate at said second
10 selected frequency, i.e. 4.0 GHz. The circulator center conductor provides a conductive path that connects the RF generator 16 to antenna 14. The signal from microwave source 36 is applied to the circulator by way of a DC blocking capacitor 54.

In use, the temperature probe 12 is normally inserted through the nose and down into the esophagus. With the apparatus operating in an alignment mode, the probe
15 antenna 22 is aligned with antenna 14 in the ablation catheter 10 by varying its position in the esophagus to maximize the received alignment signal strength as indicated by display 28. Rotating the probe 12 and its antenna 22 steers the antenna pattern in an azimuth direction while insertion and retraction of the probe shifts the antenna pattern in an axial direction. The probe 12 is optimally positioned for detection of dangerous ablation
20 temperatures when the two antennas 14 and 22 are in closest proximity as indicated by display 28 displaying a maximum received signal strength.

Following alignment, the apparatus may be switched to its ablation mode with generator 16 delivering sufficient power to antenna 14 to ablate tissue. Thus, alignment of the two antennas is usually, but not necessarily, carried out during an alignment phase
25 prior to the actual ablation procedure while generator 16 is delivering zero or sublethal power to antenna 14.

In the FIG. 2 embodiment of the invention, the catheter antenna 14 transmits a signal to probe antenna 22 to effect antenna alignment. However, the opposite may be the case as shown in FIG. 4. In the FIG. 4 apparatus, the catheter 10 is preferably of the
30 type described in the above US2007/0299488 having a radiometer incorporated right in the catheter 10 along with the antenna 14, albeit the radiometer could just as well be

outside the catheter as shown in phantom at R in FIG. 4. In either event, antenna 14 receives an RF signal from a generator 16 to ablate tissue as before. Here, the primary function of the radiometer in catheter 10 (or radiometer R) is to monitor the ablation temperature in the heart atrium H_A . For this, the radiometer detects thermal emissions picked up by antenna 14 and produces a signal which is fed to a radiometer controller 64 that controls a display 66. As in the FIG. 2 apparatus, instructions to controller 64 may be input via a keyboard (not shown).

The FIG. 4 apparatus also includes a temperature probe 12 containing an antenna 22 similar to the one in FIG. 2. A T/R switch 68 or equivalent connects antenna 22 either to a microwave source 72 similar to source 36 or to a radiometer 74 whose output controls a display 76 which may be combined with display 66.

A clock signal from the radiometer is applied by way of controller 64 to the microwave source 72 so that radiometer in catheter 10 (or radiometer R) and source 72 operate in synchronism.

Like the FIG. 2 apparatus, the FIG. 4 instrument may be operated in an alignment mode prior to the ablation procedure. For this, controller 64 may be instructed to output a control signal C to generator 16 which turns off the generator and to switch 68 which connects microwave source 72 to the antenna 22 in probe 12, while isolating the radiometer 74. Antenna 22 will thereupon transmit a pulse modulated microwave signal to the antenna 14 which is detected by the radiometer in ablation catheter 10 (or radiometer R). That radiometer will then deliver an alignment signal to controller 64. The controller controls display 66 so that the latter displays an amplitude modulated signal whose strength is indicative of the degree of alignment of the two antennas 14 and 22.

After the alignment step whose duration may be input by the operator, timed by controller 64 or based on a selected parameter, e.g. a selected maximum alignment signal strength, the controller may activate RF generator 16 and switch switch 68 so that the antenna 22 in probe 12 is disconnected from source 72 and coupled to radiometer 74. That radiometer may thereupon provide a temperature signal to display 76 so that the temperature of the esophagus wall portion E_W can be seen by the operating surgeon in

real time. The surgeon may then control generator 16 as needed to avoid overheating the esophagus.

As noted above, the present method and apparatus are applicable not only to align the ablation and temperature sensing antennas during a cardiac ablation procedure, they
5 can be used whenever two antennas have to be aligned on opposite sides of any body passage wall. In all cases, my method and apparatus, which utilize an AM pulse modulated microwave signal with synchronous detection allows optimal alignment of the two antennas because it provides high sensitivity and very good noise immunity under normal operating room conditions.

10 It will thus be seen that the objects set forth above, among those made apparent from the preceding description, are efficiently attained and, since certain changes may be made in carrying out the above method and in the constructions set forth without departing from the scope of the invention, it is intended that all matter contained in the above description or shown in the accompanying drawings shall be interpreted as
15 illustrative and not in a limiting sense.

It is also to be understood that the following claims are intended to cover all the generic and specific features of the invention described herein.

What is claimed is:

CLAIMS

- 1 1. Apparatus for aligning an ablation catheter and a temperature probe relatively for
2 an ablation procedure, said apparatus comprising
3 an ablation catheter for ablating tissue at an ablation site in a patient's body, said
4 catheter including a first antenna;
5 a temperature probe for placement in a body passage having a wall portion
6 adjacent to the ablation site so that a second antenna in said probe is positioned opposite
7 the first antenna;
8 a microwave source providing a pulse modulated microwave signal to one of said
9 first and second antennas, said signal being picked up by the other of the first and second
10 antennas;
11 a radiometer having an input in circuit with the other of the first and second
12 antennas and an output, and
13 a synchronizing device in circuit with said source and said radiometer enabling
14 the radiometer to synchronously detect said microwave signal so that the radiometer
15 output can provide an alignment signal whose strength reflects the degree of alignment of
16 the first and second antennas.
- 1 2. The apparatus defined in claim 1 wherein
2 said one antenna is the first antenna;
3 the microwave source provides the microwave signal to the first antenna by way
4 of a microwave coupler in circuit between said generator and said first antenna, and
5 the synchronizing device delivers clock pulses from the microwave source to the
6 radiometer to synchronize their operations.
- 1 3. The apparatus defined in claim 2 wherein the coupler comprises a directional
2 capacitive coupling device and a filter in circuit between the coupling device and the
3 generator.

- 1 4. The apparatus defined in claim 2 wherein the coupler comprises a diplexer.
- 1 5. The apparatus defined in claim 2 wherein the coupler comprises a ferrite
2 circulator.
- 1 6. The apparatus defined in claim 5 wherein the coupler further includes a lossy
2 transmission line connected between the circulator and the generator and a capacitor
3 connected between the circulator and the output of the microwave source.
- 1 7. The apparatus defined in claim 2 and further including
2 a generator for delivering power to the first antenna to heat the tissue whereby the
3 tissue emits radiation which is picked up by the second antenna and detected by the
4 radiometer, and
5 a control device controlling the operations of the generator and microwave source
6 in a mutually exclusive fashion so that when the microwave source is operative, said
7 radiometer output provides said alignment signal and when the generator is operative to
8 ablate tissue, the radiometer output provides a temperature signal indicating the
9 temperature of said wall portion.
- 1 8. The apparatus defined in claim 7 and further including a display device connected
2 to the radiometer output.
- 1 9. The apparatus defined in claim 1 wherein
2 said one antenna is the second antenna;
3 the microwave source provides the microwave signal to the second antenna, and
4 the radiometer input is in circuit with the first antenna.
- 1 10. The apparatus defined in claim 9 wherein the radiometer is located in the ablation
2 catheter.

- 1 11. The apparatus defined in claim 9 and further including
2 a second radiometer having an input and an output;
3 a switching device connected between the second antenna and the input of the
4 second radiometer, said microwave signal being applied to the second antenna by way of
5 said switching device;
6 a generator for delivering power to the first antenna to heat the tissue whereby the
7 tissue emits radiation which is picked up by the second antenna and detected by the
8 second radiometer producing a temperature signal at the output of the second radiometer
9 indicative of the temperature of said wall portion, and
10 a control device controlling the operations of the generator and the switching
11 device so that when the generator is operative, the switching device connects the
12 microwave source to the second antenna and when the generator is not operative, the
13 switching device connects the second antenna to the input of the second radiometer.
- 1 12. The apparatus defined in claim 11 and further including a display device
2 responsive to the signal at the output of said radiometer so that the display device
3 displays the strength of the alignment signal.
- 1 13. The apparatus defined in claim 12 and further including a second display device
2 responsive to the signal at the output of the second radiometer so that the second display
3 device displays the temperature of said wall portion.
- 1 14. A method of aligning an ablation catheter and a temperature probe for an ablation
2 procedure comprising the steps of
3 placing an ablation catheter containing a first antenna at an ablation site in a
4 patient's body;
5 positioning a temperature probe containing a second antenna in a body passage
6 having a wall portion adjacent to the ablation site so that the second antenna is positioned
7 opposite the first antenna;
8 applying a pulse modulated microwave signal to one of the first and second
9 antennas so that said signal is picked up by the other of the first and second antennas, and

10 synchronously detecting the microwave signal picked up by said other of the first
11 and second antennas to provide one alignment signal whose strength reflects the degree
12 of alignment of the first and second antennas.

1 15. The method defined in claim 14 including the additional step of applying the
2 alignment signal to a display device to display the corresponding signal strength.

1 16. The method defined in claim 15 including the steps of
2 applying the microwave signal to the first antenna, and
3 synchronously detecting the microwave signal picked up by the second antenna.

1 17. The method defined in claim 14 including the steps of
2 applying the microwave signal to the second antenna, and
3 synchronously detecting the microwave signal picked up by the first antenna.

1 18. The method defined in claim 18 wherein the microwave signal is detected by a
2 radiometer located in the ablation catheter.

1 19. The method defined in claim 14 including the additional steps of
2 delivering power to the first antenna to heat the tissue whereby the tissue emits
3 radiation which is picked up by the second antenna;
4 detecting the radiation picked up by the second antenna to provide a
5 corresponding temperature signal, and
6 controlling the applying and delivering steps so that they are operative in the
7 alternative.

1 20. The method defined in claim 19 including the additional step of applying the
2 temperature signal to a display device to display the corresponding temperature.

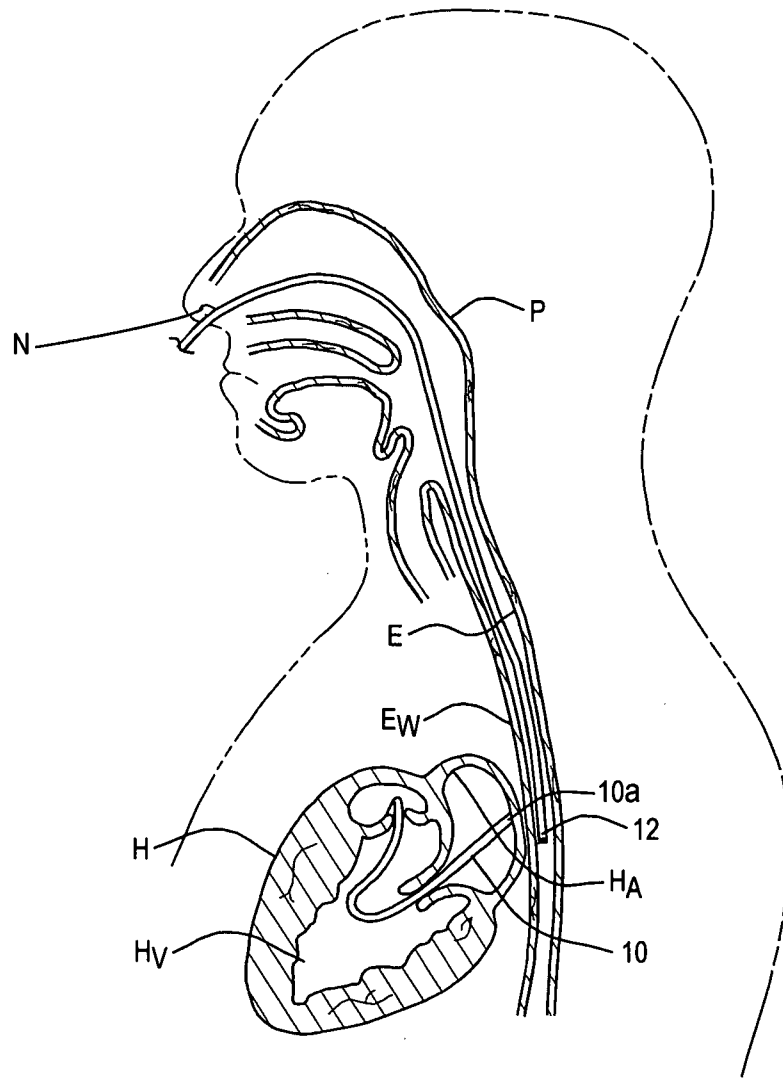

FIG. 1

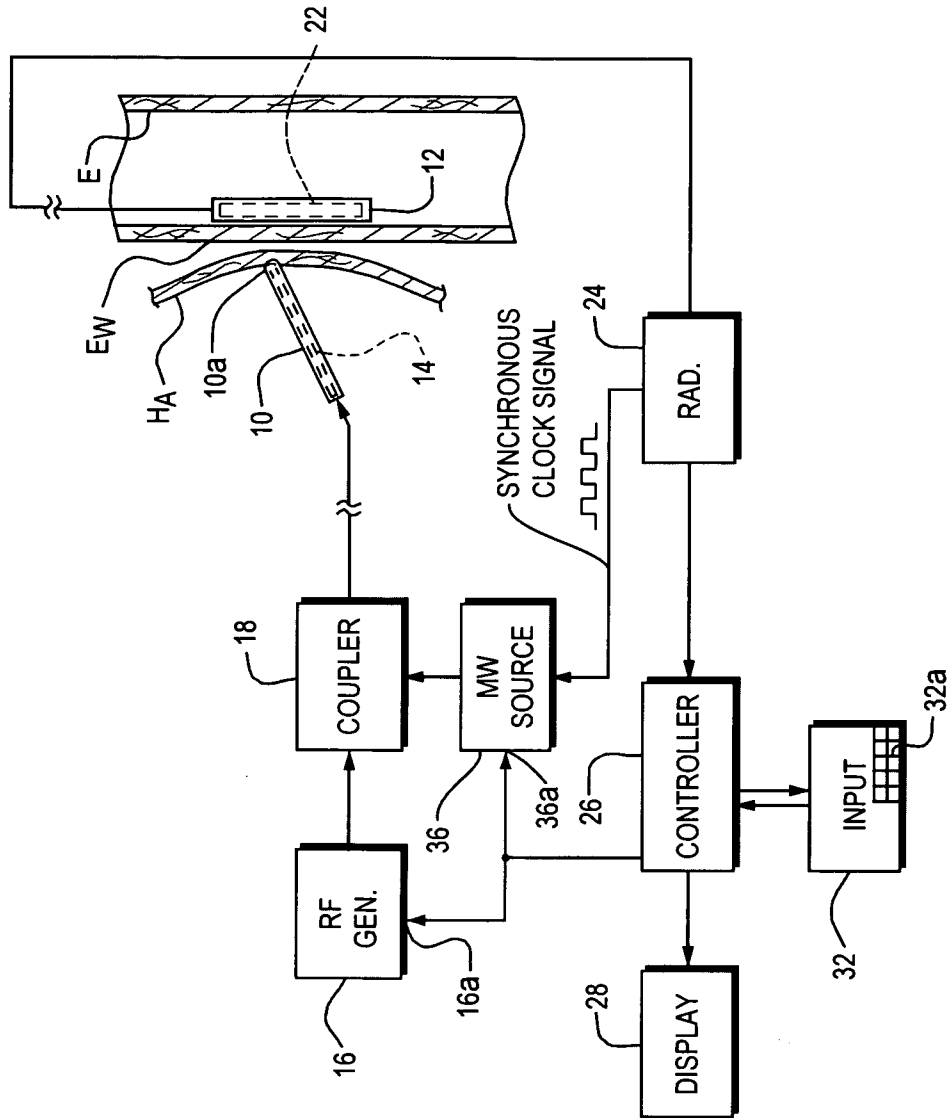

FIG. 2

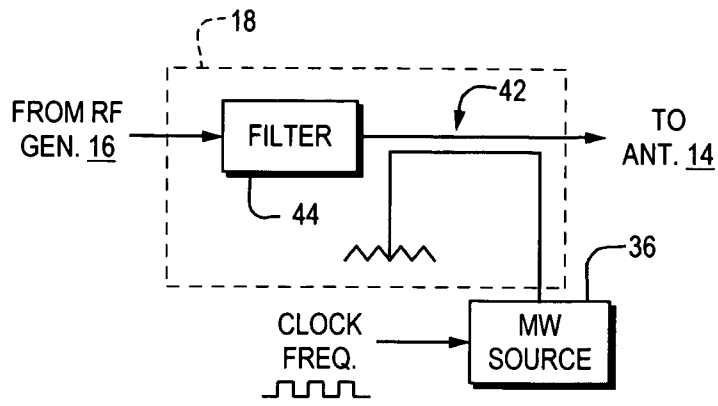

FIG. 3A

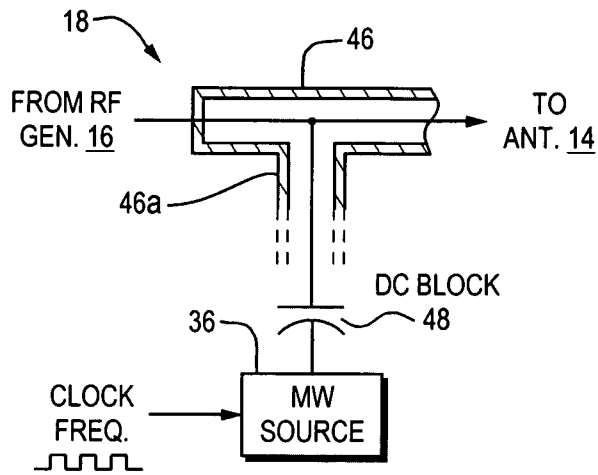

FIG. 3B

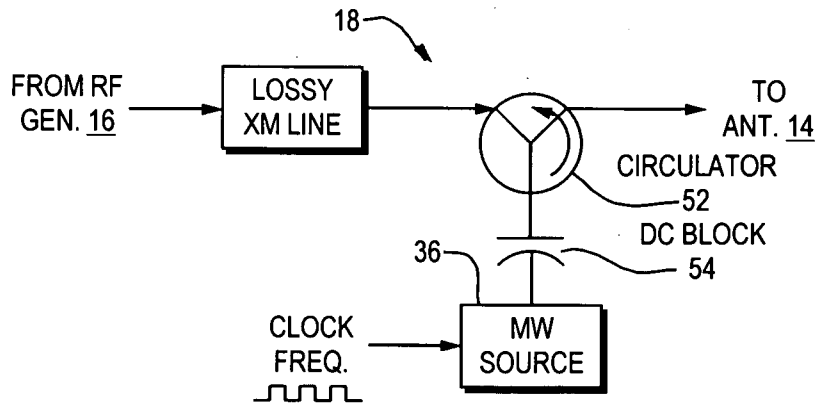

FIG. 3C

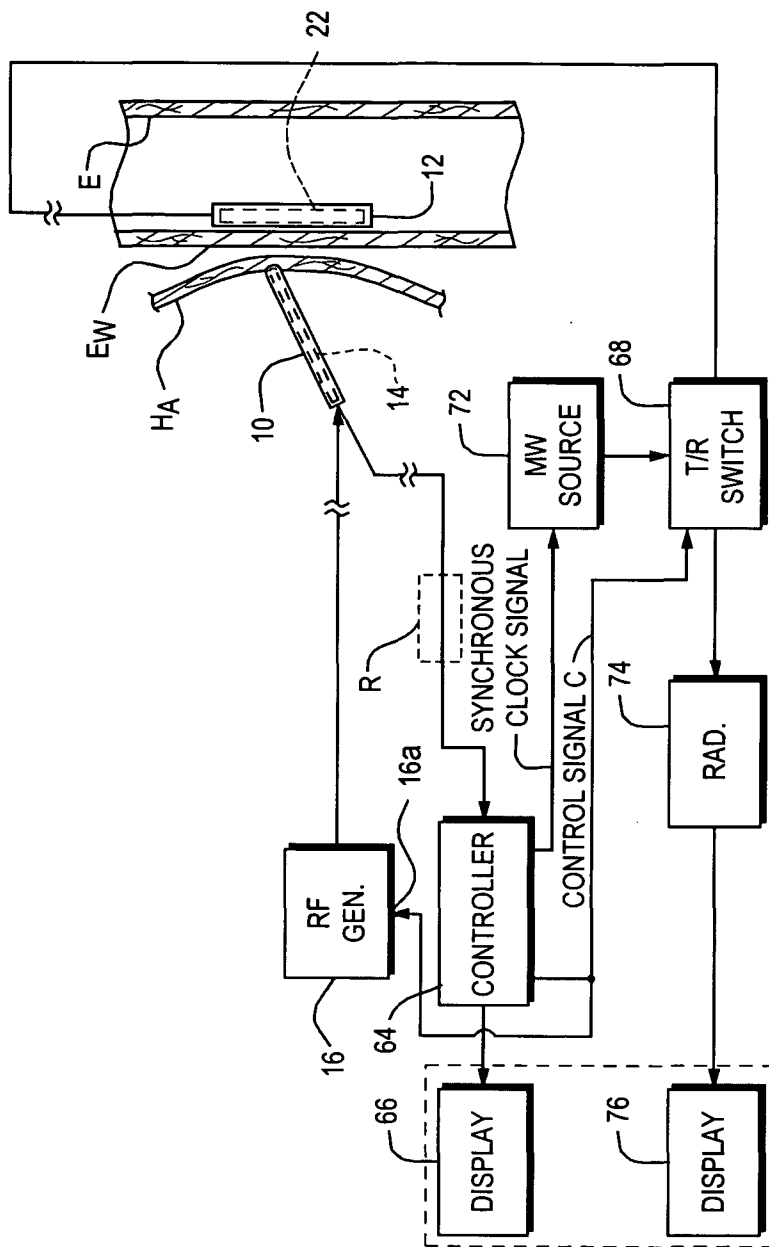

FIG. 4

INTERNATIONAL SEARCH REPORT

International application No
PCT/US2010/000129

A. CLASSIFICATION OF SUBJECT MATTER
 INV. A61B18/18 A61B5/06 G01K11/00
 ADD. A61B5/00 A61B17/00 A61B18/14

According to International Patent Classification (IPC) or to both national classification and IPC

B. FIELDS SEARCHED

Minimum documentation searched (classification system followed by classification symbols)
A61B G01K

Documentation searched other than minimum documentation to the extent that such documents are included in the fields searched

Electronic data base consulted during the international search (name of data base and, where practical, search terms used)

EPO-Internal, WPI Data

C. DOCUMENTS CONSIDERED TO BE RELEVANT

Category*	Citation of document, with indication, where appropriate, of the relevant passages	Relevant to claim No.
Y A	EP 0 485 323 A1 (BIODAN MEDICAL SYSTEMS LTD [IL]) 13 May 1992 (1992-05-13) column 3, line 35 - column 5, line 50 figures 1,4,5 claim 1	1-6,9,10 7,8, 11-13
Y A	US 2007/299488 A1 (CARR KENNETH L [US]) 27 December 2007 (2007-12-27) cited in the application paragraphs [0035] - [0050] figure 1	1-6,9,10 7,8, 11-13
Y A	US 2006/106375 A1 (WERNETH RANDELL L [US] ET AL) 18 May 2006 (2006-05-18) paragraphs [0055] - [0057], [0075] - [0088] figure 5	1-6,9,10 7,8, 11-13
	----- -/--	

Further documents are listed in the continuation of Box C.

See patent family annex.

* Special categories of cited documents :

- "A" document defining the general state of the art which is not considered to be of particular relevance
- "E" earlier document but published on or after the international filing date
- "L" document which may throw doubts on priority claim(s) or which is cited to establish the publication date of another citation or other special reason (as specified)
- "O" document referring to an oral disclosure, use, exhibition or other means
- "P" document published prior to the international filing date but later than the priority date claimed

- "T" later document published after the international filing date or priority date and not in conflict with the application but cited to understand the principle or theory underlying the invention
- "X" document of particular relevance; the claimed invention cannot be considered novel or cannot be considered to involve an inventive step when the document is taken alone
- "Y" document of particular relevance; the claimed invention cannot be considered to involve an inventive step when the document is combined with one or more other such documents, such combination being obvious to a person skilled in the art.
- "&" document member of the same patent family

Date of the actual completion of the international search

28 April 2010

Date of mailing of the international search report

07/05/2010

Name and mailing address of the ISA/

European Patent Office, P.B. 5818 Patentlaan 2
 NL - 2280 HV Rijswijk
 Tel. (+31-70) 340-2040,
 Fax: (+31-70) 340-3016

Authorized officer

Grochol, Jana

INTERNATIONAL SEARCH REPORT

International application No
PCT/US2010/000129

C(Continuation). DOCUMENTS CONSIDERED TO BE RELEVANT

Category*	Citation of document, with indication, where appropriate, of the relevant passages	Relevant to claim No.
A	US 4 346 716 A (CARR KENNETH L) 31 August 1982 (1982-08-31) column 7, line 12 - column 11, line 15 figure 1 -----	3-6

INTERNATIONAL SEARCH REPORT

International application No.
PCT/US2010/000129

Box No. II Observations where certain claims were found unsearchable (Continuation of item 2 of first sheet)

This international search report has not been established in respect of certain claims under Article 17(2)(a) for the following reasons:

1. Claims Nos.: 14-20
because they relate to subject matter not required to be searched by this Authority, namely:
Rule 39.1(iv) PCT - Method for treatment of the human or animal body by surgery
2. Claims Nos.:
because they relate to parts of the international application that do not comply with the prescribed requirements to such an extent that no meaningful international search can be carried out, specifically:
3. Claims Nos.:
because they are dependent claims and are not drafted in accordance with the second and third sentences of Rule 6.4(a).

Box No. III Observations where unity of invention is lacking (Continuation of item 3 of first sheet)

This International Searching Authority found multiple inventions in this international application, as follows:

1. As all required additional search fees were timely paid by the applicant, this international search report covers all searchable claims.
2. As all searchable claims could be searched without effort justifying an additional fees, this Authority did not invite payment of additional fees.
3. As only some of the required additional search fees were timely paid by the applicant, this international search report covers only those claims for which fees were paid, specifically claims Nos.:
4. No required additional search fees were timely paid by the applicant. Consequently, this international search report is restricted to the invention first mentioned in the claims; it is covered by claims Nos.:

Remark on Protest

- The additional search fees were accompanied by the applicant's protest and, where applicable, the payment of a protest fee.
- The additional search fees were accompanied by the applicant's protest but the applicable protest fee was not paid within the time limit specified in the invitation.
- No protest accompanied the payment of additional search fees.

INTERNATIONAL SEARCH REPORT

Information on patent family members

International application No PCT/US2010/000129

Patent document cited in search report	Publication date	Patent family member(s)	Publication date
EP 0485323 A1	13-05-1992	JP 5103841 A	27-04-1993
US 2007299488 A1	27-12-2007	EP 2051617 A1 JP 2010500053 T WO 2008002517 A1	29-04-2009 07-01-2010 03-01-2008
US 2006106375 A1	18-05-2006	AU 2005306826 A1 CA 2587331 A1 EP 1824405 A2 WO 2006055286 A2	26-05-2006 26-05-2006 29-08-2007 26-05-2006
US 4346716 A	31-08-1982	JP 57020249 A	02-02-1982

专利名称(译)	用于对准消融导管和温度探针以进行消融手术的方法和设备		
公开(公告)号	EP2389132A1	公开(公告)日	2011-11-30
申请号	EP2010704236	申请日	2010-01-20
[标]申请(专利权)人(译)	默里蒂安医疗系统有限责任公司		
申请(专利权)人(译)	MERIDIAN医疗系统有限责任公司		
当前申请(专利权)人(译)	MERIDIAN医疗系统有限责任公司		
[标]发明人	CARR KENNETH L ALLISON ROBERT C		
发明人	CARR, KENNETH, L. ALLISON, ROBERT, C.		
IPC分类号	A61B18/18 A61B5/06 G01K11/00 A61B5/00 A61B17/00 A61B18/14		
CPC分类号	A61B18/18 A61B5/0507 A61B5/06 A61B5/061 A61B18/1815 G01K11/006 G01K13/002		
代理机构(译)	鲁普雷希特, KAY		
优先权	12/356205 2009-01-20 US		
其他公开文献	EP2389132B1		
外部链接	Espacenet		

摘要(译)

用于相对于消融手术对准消融导管和温度探针的装置包括消融导管，该消融导管具有用于消融患者体内消融部位处的组织的第一天线和用于放置在具有邻近的壁部分的身体通道中的温度探针。消融部位使探头中的第二个天线与第一个天线相对。微波源向其中一个天线提供脉冲调制微波信号，而辐射计与另一个天线在电路中。具有微波源和辐射计的电路中的同步装置使辐射计能够同步地检测微波信号，使得辐射计提供对准信号，其强度反映第一和第二天线的对准程度，该信号可用于控制对齐显示。还公开了使用该装置的对准方法。