

(19) World Intellectual Property Organization  
International Bureau



(43) International Publication Date  
23 April 2009 (23.04.2009)

PCT

(10) International Publication Number  
WO 2009/051863 A1

(51) International Patent Classification:  
A61B 5/04 (2006.01) G01K 13/00 (2006.01)  
A61B 5/00 (2006.01)

(74) Agents: PURCELL, Robert, E. et al.; Hiscock & Barclay, LLP, One Park Place, 300 South State Street, Syracuse, NY 13202-2078 (US).

(21) International Application Number:  
PCT/US2008/068004

(81) Designated States (unless otherwise indicated, for every kind of national protection available): AE, AG, AL, AM, AO, AT, AU, AZ, BA, BB, BG, BH, BR, BW, BY, BZ, CA, CH, CN, CO, CR, CU, CZ, DE, DK, DM, DO, DZ, EC, EE, EG, ES, FI, GB, GD, GE, GH, GM, GT, HN, HR, HU, ID, IL, IN, IS, JP, KE, KG, KM, KN, KP, KR, KZ, LA, LC, LK, LR, LS, LT, LU, LY, MA, MD, ME, MG, MK, MN, MW, MX, MY, MZ, NA, NG, NI, NO, NZ, OM, PG, PH, PL, PT, RO, RS, RU, SC, SD, SE, SG, SK, SL, SM, SV, SY, TJ, TM, TN, TR, TT, TZ, UA, UG, US, UZ, VC, VN, ZA, ZM, ZW.

(22) International Filing Date: 24 June 2008 (24.06.2008)

(25) Filing Language: English

(26) Publication Language: English

(30) Priority Data:  
11/873,046 16 October 2007 (16.10.2007) US

(71) Applicant (for all designated States except US): WELCH ALLYN, INC. [US/US]; 4341 State Street Road, Skaneateles Falls, NY 13153 (US).

(84) Designated States (unless otherwise indicated, for every kind of regional protection available): ARIPO (BW, GH, GM, KE, LS, MW, MZ, NA, SD, SL, SZ, TZ, UG, ZM, ZW), Eurasian (AM, AZ, BY, KG, KZ, MD, RU, TJ, TM), European (AT, BE, BG, CH, CY, CZ, DE, DK, EE, ES, FI, FR, GB, GR, HR, HU, IE, IS, IT, LT, LU, LV, MC, MT, NL, NO, PL, PT, RO, SE, SI, SK, TR), OAPI (BF, BJ, CF, CG, CI, CM, GA, GN, GQ, GW, ML, MR, NE, SN, TD, TG).

(72) Inventors; and

(75) Inventors/Applicants (for US only): QUINN, David, E. [US/US]; 3223 Turnpike Road, Auburn, NY 13021 (US). MARTIN, Scott, A. [US/US]; 106 Golden Meadow Way, Warners, NY 13164 (US). LANE, John, A.; 2815 Sharon Street, Weedsport, NY 13166 (US). MEYERSON, Craig, M. [US/US]; 953 Westmoreland Avenue, Syracuse, NY 13210 (US). CORCORAN, Clare, L. [US/US]; 4241 Huntingcreek Drive, Clay, NY 13041 (US).

Published:  
— with international search report

(54) Title: TEMPERATURE PATCH AND METHOD OF USING THE SAME

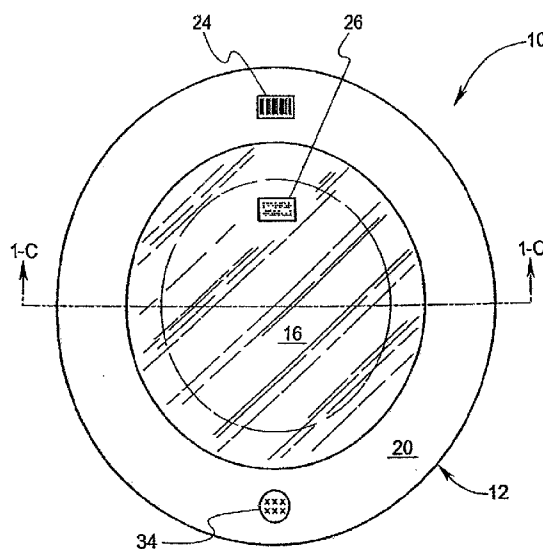

Fig. 1-B

(57) Abstract: A patch having an infrared (IR) target is placed proximate to the surface of a mammal. The patch may include an insulator for protecting the target from exterior, ambient IR and may include bar codes or other indicia uniquely associated with either the patch or the mammal. The patch may also include a bio-reactive agent for indicating characteristics such as the pH of the mammal's skin. The patch may also include a thermometer for sensing the level of IR radiation from the IR target and may include a display of the temperature associated with such a level. The patch may also include a transmitter for wirelessly communicating information about such level to a remote location. A method of using the patch is also disclosed.

WO 2009/051863 A1

## TEMPERATURE PATCH AND METHOD OF USING THE SAME

### FIELD OF THE INVENTION

[0001] This invention relates, in one embodiment, to measuring and/or monitoring body temperature of a mammal, especially a human.

### BACKGROUND OF THE INVENTION

[0002] The core body temperature of a mammal, especially human, is one of the so-called vital signs that provides a strong indication of the health or medical condition of the mammal. Consequently, accurately assessing the core body temperature, frequently noting the core body temperature, and observing trends in the core body temperature are extremely important criteria in evaluating the medical condition of a mammal and in evaluating whether medical treatments are working desirably or should be implemented.

[0003] Traditional thermometers include those materials, both liquid or solid, that expand or otherwise change their physical conformation when heated. Examples include mercury and ethanol based thermometers. Such traditional thermometers usually require long equilibration times which require them to be disposed adjacent to or within orifices of a mammal for long times in order to gain a roughly accurate indication of the core body temperature.

[0004] Another disadvantage of traditional thermometers is that their use often causes discomfort to a patient or disrupts a patient's sleep.

[0005] It has been known that the body of a mammal radiates infrared radiation, which is generally associated with “heat” being radiated from the body, and which in turn is generally related to the core body temperature of the mammal. Infrared thermometers capable of sensing the infrared (“IR”) radiation emitted near the skin or other external surface of a mammal have been utilized to provide a temperature that correlates with the level or amount of IR radiation sensed. Such thermometers, however, are often inaccurate because the level of IR radiation from such a surface may be affected by sources other than the core body temperature, such as the temperature of the air in the vicinity of the surface and the presence of perspiration on the surface, thereby altering the emissivity or reflectivity of the measurement site.

[0006] One particularly advantageous location to use an IR thermometer is deep into the inner ear using a so-called tympanic probe, however, the inner ear is often occluded and the ear canal is extremely tortuous, such that the probe often does not reach deep enough into the inner ear to gain an unobstructed sighting in order to obtain an accurate reading. Moreover, the use of such a probe can cause some discomfort to a patient, and often requires that a patient be turned or moved in order to use the probe.

#### **SUMMARY OF THE INVENTION**

[0007] A patch having an IR target is placed proximate to the surface of a mammal. The patch may include an insulator for protecting the target from exterior, ambient IR radiation and may include bar codes or other indicia uniquely associated with either the patch or the mammal. The patch may also include a bio-reactive agent for indicating characteristics such as the pH of the mammal’s skin. The patch may also include a

thermometer for sensing the level of IR radiation from the IR target and may include a display of the temperature associated with such a level. The patch may also include a transmitter for wirelessly communicating information about such level to a remote location. A method of using the patch is also disclosed.

### **BRIEF DESCRIPTION OF THE DRAWINGS**

[0008] The present invention will be described with reference to the accompanying drawings, wherein:

Figure 1A is a side schematic illustration of a patch in accordance with one embodiment of the present invention;

Figure 1B is a top schematic illustration of the patch shown in Figure 1A;

Figure 1C is a cross-sectional view of the patch shown in Figure 1B taken along the lines 1C-1C;

Figure 2 is a perspective schematic illustration of the patch in accordance with yet another embodiment of the present invention;

Figure 3 is a schematic illustration of yet another patch in accordance with an embodiment of the present invention;

Figure 4 is a schematic illustration of a display screen that might be utilized in connection with the method of using a patch in accordance with the present invention; and

Figure 5 is a schematic illustration of another display that may be utilized in connection with the method of using a patch in accordance with the present invention.

**DETAILED DESCRIPTION OF A PREFERRED EMBODIMENT**

[0009] Aspects of the present invention will be described with reference to the accompanying drawings wherein like reference numerals refer to the same item. It should be appreciated that the features described herein are exemplary and illustrative only, and that the present invention encompasses both modifications of these features and different features.

[0010] There is shown in Figures 1A-C a patch 10 constructed in accordance with one embodiment of the present invention. Patch 10 includes a generally disk-shaped base 12 having a circular periphery upon which is centrally mounted an insulator 14 generally configured in the shape of a ring. Patch 10 further includes preferably a sheet or film 16 of material that is transparent preferably to both infrared and visible radiation. The base 12 includes a central disk-shaped core of an infrared target 18 preferably that is co-extensive with the inner annular edge of insulator 14. The base 12 further includes a supporting member 20 preferably fashioned as a ring having an internal peripheral edge that intimately contacts and abuts the peripheral edge of the IR target 18. The patch 10 may also include an adhesive coating or layer 22 disposed along the bottom surface of the supporting member 20 that may be used to selectively secure the patch 10 to the skin or other surface of a mammal. The adhesive coating may, for example, be the same type that is used in connection with either skin bandages or EKG electrodes that are typically placed on the chest of a human for monitoring heart activity.

[0011] As especially shown in Figure 1C, when the patch 10 is placed preferably against the skin of a mammal, the IR target 18 is placed in intimate contact with the skin or other surface. Thermal radiation or energy passes from the body, through its skin or other

surface and into the IR target 18 through conduction, convection, or radiation. The IR member 20 then emits infrared radiation according to a known degree of “emissivity” associated with the material from which the IR target 18 is fabricated. The nature of “emissivity” in this patent application relies upon the definition referenced in U.S. Patent No. 4,659,234 to Brouwer, rather than that referenced in U.S. Patent No. 7,037,083 to O’Neil. The IR target 18 may be fashioned, for example, from a variety of plastics, paper and other cellulose-based materials, fabric, metal foil, and combinations thereof. Examples of suitable metals include aluminum, brass, copper, and gold. Preferably the IR target material has a relatively high degree of “emissivity”, at least about 0.8, 0.9, and, even more preferably, 0.95. Polyethylene film having an “emissivity” of 0.99, has been found especially efficacious.

**[0012]** One factor that influences the rate of heating of the IR target 18 is its mass, which is preferably less than 10.0 milligrams, even more preferably less than about 5.0 milligrams, and even more preferably less than about 1.00 milligrams. Preferably the base 12 is extremely thin, which helps the patch 10 from being obtrusive when operably disposed proximate to the surface of a mammal. Preferably the thickness is in the range of about one one-thousandths to ten one-thousandths of an inch, and very preferably is in the range of about 0.5 one-thousandths to three one-thousandths of an inch. Preferably also the diameter of the IR target 18 is relatively small, within the range of about one-half of an inch to one inch, or stated alternatively, possesses a surface area of about one-fifth to three-quarters of a square inch. However, the invention contemplates that the diameter of the IR target 18 may be larger, for example, three inches or even four inches.

[0013] The supporting member 20 may be fashioned of any suitable material, such as polyethylene, polypropylene, starched-based polymers, aluminum, gold plating, and the like. The supporting member 20 may also be formed as a laminate of different materials.

[0014] The insulator 14 may be formed of any suitable material, such as a foam, with the material very preferably helping to eliminate the presence of IR radiation within the space defined by the IR target 18, the insulator 14, and the film 16, as best shown in Figure 1C, from infrared radiation other than that emitted from the IR target 18. The insulator 14 also helps to reduce and minimize the effects of convection or evaporation on the target measurement area. The thickness or height of the insulator 14 as shown in Figures 1A and 1C may vary within a wide range, but preferably the overall height or thickness of the patch 10 as shown in Figures 1A and 1C is less than about one-sixth of an inch (and thus it will be appreciated that the components of the patch 10 are not necessarily drawn to scale in Figures 1A and 1C).

[0015] The film 16 is preferably fashioned of a flexible sheet of material that is preferably transparent to both infrared and visible light. It is preferably extremely thin, such as less than about one-thousandths of an inch. The film 16 provides an additional insulating media that helps minimize the presence of IR radiation within the space defined by the film 16, the insulator 14, and the target 18 from sources other than the IR target 18. The film 16 is preferably transparent to IR radiation so that a probe associated with an IR thermometer may be placed near or against the film 16 and detect the IR radiation being emitted by the IR target 18, so as to obtain a reading of the associated temperature of the body of the mammal. It should be appreciated that the present invention contemplates that the film 16 might not be incorporated into the patch 10.

[0016] One or more, and preferably all, of the components of the patch 10 are fashioned of flexible materials so that the patch 10 may readily adapt and conform to the contour of the surface of the mammal where the patch 10 is to be disposed.

[0017] The present invention also contemplates that various indicia may be uniquely associated with the patch 10 such as by printing the indicia on the surface of the patch 10, for example on the upper surface of either the supporting member 20 or the IR target 18 or both. Alternatively the indicia may be disposed on adhesive labels that are affixed to the patch 10, or engraved on the patch, for example. Indicia may, for example, be in the form of a bar code or other pattern capable of being recognized by a machine, an RFID device, a photodiode, a magnetic medium, or physical deformation of a portion of the patch 10, such as by a hole punch pattern or Braille. The indicia may or may not be machine-readable and may or may not be visible to the human eye.

[0018] Figure 1B shows two such indicia 24, 26, with the indicia 24 being placed on the upper surface of the supporting member 20, and the other indicia 26 being disposed on the upper surface of the IR target 18. One of the indicia 24, 26 may be uniquely associated with the patch 10, and the other indicia may be associated with the particular location on the mammal where the patch 10 is to be placed, e.g., under the right bicep (such as where more than one patch is placed proximate to the surface of the same mammal). Preferably one or more of the indicia 24, 26 are placed over the IR target 18, and they are of a character that does not adversely affect the IR emissions of the IR target 18, so that the IR thermometer probe may also be fitted with a mechanism that reads the indicia 24, 26 when taking a reading of the IR radiation emitted from the IR target 18. Alternatively, the indicia may be alpha-numeric and a person operating the IR

thermometer probe could manually input the alpha-numeric information into the IR thermometer whereby the same would be associated with the reading of the IR radiation from the IR target 18.

[0019] The invention contemplates that the IR thermometer could be a wall-mounted device or a battery-operated hand-held device capable of taking IR radiation readings and indicia readings from one or more patches 10 on the same mammal and taking such readings from patches 10 on different mammals. In this regard, the invention further contemplates that the IR thermometer may be included in a patch 10, as best shown in Figure 2. Instead of having a film 16, or in addition to having a film 16, the patch 10 may include an IR thermometer 28 that rests as a cap upon the insulator 14 and that preferably possesses a disk shape with a circular periphery co-extensive with the outer peripheral edge of the insulator 14. Alternatively, the thermometer 28 could be set down within the insulator 14, with the peripheral edge of the IR thermometer 28 being co-extensive with and in intimate contact with the inner peripheral edge of the insulator 14 and affixed to the insulator 14 by means of adhesive or other bonding agent, a press fit or snap fit relationship, or other suitable means. The IR thermometer 28 would preferably include a self-contained power source, such as a battery, that could constantly or intermittently sense the IR radiation being emitted by the IR target 18. The invention also contemplates that the IR thermometer 28 may be selectively programmable by means of a computer chip to sense the IR radiation at a selected one of a plurality of time interval frequencies. Additionally, the IR thermometer 28 could also be provided with a device for reading the indicia 24, 26, especially such indicia disposed on the top surface of the IR target 18. The IR thermometer 28 could also include a computer chip

programmed with the known “emissivity” of the IR target 18 and for translating the level of IR radiation sensed by the IR thermometer 28 into an associated temperature reading (in Fahrenheit or in Celsius or in another scale) and could further include a display 30 for indicating the associated temperature. Additionally, the IR thermometer 28 could be provided with a programmable chip that translates the indicia into humanly comprehensive information, such as the name of the patient, for example, which also could be revealed in the display 30.

**[0020]** In one embodiment, the information depicted in the display 30 could be scanned by a wall-mounted or hand-held reading device, or alternatively, could be viewed by a human and manually recorded on a chart or manually inputted into an electro-mechanical recording device.

**[0021]** The invention also contemplates that the IR thermometer 28 includes a wireless transmitting device that may be powered by a battery within the IR thermometer 28. The transmitter could transmit to a remote location any or all of the following: the level of IR radiation being sensed by the IR thermometer 28, the correlated temperature associated with that IR level of radiation, the indicia, or the information correlated with the indicia. Such information could be further processed and recorded at the remote location.

**[0022]** The film 16 may be secured to the insulator 14, and the insulator 14 may be secured to the supporting member 20 by means of an adhesive or other bonding agent, thermal fusion, or any other suitable means. The IR target 18 similarly may be attached at its outer peripheral edge to the inner peripheral edge of the supporting member 20 by means of an adhesive or other bonding agent, thermal fusion, a press fit or snap fit relationship, sewn threads, staples, or other similar means. It should be appreciated that

the invention contemplates that instead of the IR target 18, the supporting member 20, the insulator 14, and the film 16 having circular peripheral configurations, a wide variety of configurations may be effectively utilized. It should also be appreciated that the invention contemplates that the insulator 14 and the supporting member 20 may be fashioned of the same material. Likewise, it should be appreciated that the IR target 18 may form the entire base 12 and that the base 12 may extend at a variety of different lengths with respect to the outer peripheral edge of the insulator 14.

**[0023]** With regard to the embodiment shown in Figure 2, it is contemplated that preferably the components of the patch 10 other than the IR thermometer 28 would be relatively inexpensive and disposable, such that they are not re-used, or are limited to a small number of uses (such as to a single patient for a single hospital stay), whereas the IR thermometer 28 itself could be re-used. Also preferably the disposable components are essentially biodegradable. As such, it is contemplated that the IR thermometer 28 could be selectively adhesively attached to either the film 16 or the insulator 14. In another embodiment, the IR thermometer 28 could have fixedly secured thereto either the film 16, or the insulator 14, or both, and then the insulator 14 would be selectively, adhesively secured to the base 12. It should be further understood that, as disclosed in co-pending U.S. Patent Application Serial No. 11/678,657, filed on February 26, 2007, such an IR thermometer 28 could be used without any film 16 or insulator 14.

**[0024]** From the foregoing, it should be appreciated that the patch 10 may be placed proximate to various surface regions of a mammal, including those that are comfortable for the mammal as well as those regions that are readily accessible to a nurse, doctor, or other medical practitioner. More than one patch 10 may be placed on the mammal, both

so as to provide more than one independent assessment of the body temperature, and so that if the patch 10 is temporarily inaccessible (such as a patient being in a position where the patch 10 is between the patient and an underlying bed), the temperature reading may still be taken without disturbing the patient.

**[0025]** As best shown in Figure 3, in another embodiment of the invention, a patch 10 in all respects similar to that shown in Figure 2 is depicted on the left side of Figure 3, however, the display 30 is remotely located with respect to the other components of the patch 10. The display 30 is electronically connected to the IR thermometer 28 in patch 10 by means of a wire 32 or other electrical pathway. In such an embodiment, the patch 10 may be located in a surface region of the mammal that is relatively inaccessible or that inhibits wireless transmission, but, the display 30 could be positioned at a different, more accessible location. The display 30 may be positioned by means of an adhesive, for example, at a different location on the mammal's body.

**[0026]** It is also contemplated that the patch 10 be provided with a bio-reactive agent or material 34, as best shown in Figure 1B, that is capable of being altered when in the presence of a pre-selected bio-chemical property associated with the surface of the mammal, and where the alteration can be detected either visually or through a machine. Bio-reactive material 34 may be implanted into the IR target 18 or in the supporting member 20 and may extend therethrough so as to be in contact with the skin surface. In a simple example, the bio-reactive 40 may consist of "litmus" paper that changes to one of two colors, depending upon the pH of the liquid or other material in which the bio-reactive material 34 is in contact. The bio-reactive material 34 may be sensitive to and altered by liquid or gas effluents from the mammal's skin, such as perspiration. The bio-

chemical components of such effluents may be indicative of certain health or medical conditions of the mammal, which include blood glucose levels, jaundice, lead contamination, turgor, infections, anemia, and the like. The alteration may be detected by spectroscopy, which involves an analysis of the spectral distribution of a known light source after being reflected from the surface of the bio-reactive material 34.

[0027] Figures 4 and 5 each show a display of information that may be obtained from a patch 10 in accordance with the present invention. The displays may be on a hand-held device, a wall-mounted device, or on a computer screen at a remote location. In the display shown in Figure 4, the various information about the patient is disclosed and there is an indication that there are two patches 10 disposed on the patient as well as an indication as to where the patches 10 are located. The display also indicates that there are no patches 10 with bio-reactive agents. The display further indicates the dates and times of the last three temperature (and possibly bio-reactive agent) readings as well as the values of the temperature (and any bio-reactive) readings. Finally, the current nurse I.D. number and the current date and time are given. Such a display is especially efficacious with a hand-held IR thermometer or other device, which helps indicate how many patches 10 are on a patient and where they are located as well as what temperature reading is associated with which patch 10. The nurse I.D. number may be manually inputted into the IR thermometer or other device or may be inputted by reading a bar code or other indicia associated with the nurse, which is then inputted into a computer.

[0028] Similarly, Figure 5 depicts information about the patient as well as a graph (with legend) giving the temperature readings from each of the two patches 10 over the last eight readings as well as the dates and times of those eight readings. It will be

appreciated illustratively in Figure 5 that over about a fifteen hour period (from 16:29 on March 6, 2007 to 7:20 on March 7, 2007), the patient's temperature dropped from approximately 102.5 degrees Fahrenheit to under 99 degrees Fahrenheit. And that over the most recent ten hours, the patient's temperature stabilized between 98 and 99 degrees Fahrenheit. As such, the graph indicates the recent temperature trend of the patient.

**[0029]** While the invention has been described with reference to preferred embodiments, it will be understood by those skilled in the art that various changes may be made and equivalents may be substituted for features thereof to adapt to particular situations without departing from the scope of the invention. Therefore, it is intended that the invention not be limited to the particular embodiments disclosed herein for carrying out the invention.

What is claimed is:

1. A patch adapted for placement proximate to a surface region of a mammal, said patch including:
  - a. an infrared target for receiving thermal energy from said surface region and for emitting infrared radiation according to a substantially known emissivity property whereby, when said target is placed proximate to said surface region, the characteristics of infrared radiation emitted by said target substantially correspond to the temperature of said surface region; and
  - b. an insulator for protecting said target from the thermal effects of media adjacent to, but different from, said surface region.
2. A patch according to claim 1 further including an adhesive for selectively, removably securing said target in a placement proximate to said surface region.
3. A patch according to claim 1 wherein said insulator includes a foam structure.
4. A patch according to claim 1 wherein said patch is configured substantially as a circular disk, wherein said insulator includes a substantially ring-shaped foam structure possessing a central aperture and disposed adjacent to said target such that infrared radiation emitted by said target may pass through the central aperture of said foam structure.
5. A patch according to claim 4 wherein said insulator further includes a substantially transparent sheet disposed over said central aperture.
6. A patch according to claim 1 including indicia uniquely associated with said patch.

7. A patch according to claim 6 wherein said indicia is essentially visible to the human eye.
8. A patch according to claim 6 wherein said indicia is essentially invisible to the human eye.
9. A patch according to claim 6 wherein said indicia is selected from the group consisting of a bar code or other pattern adapted to be recognized by a machine, an RFID device, a photodiode, a magnetic medium, and physical deformation of a portion of the patch.
10. A patch according to claim 1 including indicia uniquely associated with a particular location on the mammal where said patch is to be placed.
11. A patch according to claim 10 wherein said indicia is essentially visible to the human eye.
12. A patch according to claim 10 wherein said indicia is essentially invisible to the human eye.
13. A patch according to claim 10 wherein said indicia is selected from the group consisting of a bar code or other pattern adapted to be recognized by a machine, an RFID device, a photodiode, a magnetic medium, and physical deformation of a portion of the patch.
14. A patch according to claim 1 wherein said patch includes a bio-reactive agent having a characteristic that is capable of being detectively altered in the presence of a pre-selected bio-chemical property of said surface region.
15. A patch according to claim 14 wherein said property is essentially the pH value of said surface region.

16. A patch according to claim 14 wherein said bio-reactive agent characteristic is capable of being altered in a manner detectable through spectroscopy.
17. A patch according to claim 1 wherein said target possesses a substantially wafer shape and wherein the thickness of said target is within the range of about 0.5 – 10 one-thousandths of an inch.
18. A patch according to claim 17 wherein the thickness of said target is within the range of about 0.5 – 3 one-thousandths of an inch.
19. A patch according to claim 1 wherein said patch possesses a substantially wafer shape and wherein the thickness of said patch is less than about one-sixth of an inch.
20. A patch according to claim 1 further including an infrared thermometer disposed proximate to said target for sensing infrared radiation emitted by said target.
21. A patch according to claim 1 further including an infrared thermometer adapted to be selectively disposed proximate to said target for sensing infrared radiation emitted by said target.
22. A patch according to claim 4 further including an infrared thermometer disposed within said central aperture for sensing infrared radiation emitted by said target.
23. A patch according to claim 4 further including an infrared thermometer selectively disposed within said central aperture for sensing infrared radiation emitted by said target.
24. A patch according to claim 4 further including an infrared thermometer disposed so as to sense infrared radiation emitted by said target and passing through said central aperture.

25. A patch according to claim 4 further including an infrared thermometer selectively disposed so as to sense infrared radiation emitted by said target and passing through said central aperture.
26. A patch according to claim 1 wherein said target and said insulator are flexible so as to permit said patch to adapt and conform to the contour of said surface region.
27. A patch according to claim 1 wherein said target and said insulator are adapted to be disposable and are fashioned of essentially biodegradable materials.
28. A patch adapted for placement proximate to a surface region of a mammal, said patch including:
- a. an infrared target for receiving thermal energy from said surface region and for emitting infrared radiation according to a substantially known emissivity property whereby, when said target is placed proximate to said surface region, the characteristics of infrared radiation emitted by said target substantially correspond to the temperature of said surface region;
  - b. means for selectively maintaining said target in a position proximate to a surface region of a mammal; and
  - c. indicia uniquely associated with said patch.
29. A patch according to claim 28 wherein said indicia is essentially visible to the human eye.
30. A patch according to claim 28 wherein said indicia is essentially invisible to the human eye.
31. A patch according to claim 28 wherein said indicia is selected from the group consisting of a bar code or other pattern adapted to be recognized by a machine, an RFID

device, a photodiode, a magnetic medium, and physical deformation of a portion of the patch.

32. A patch according to claim 28 wherein said patch includes a bio-reactive agent having a characteristic that is capable of being detectively altered in the presence of a pre-selected bio-chemical property of said surface region.

33. A patch according to claim 32 wherein said property is essentially the pH value of said surface region.

34. A patch according to claim 32 wherein said bio-reactive agent characteristic is capable of being altered in a manner detectable through spectroscopy.

35. A patch according to claim 28 further including indicia uniquely associated with a particular location on the mammal where said patch is to be placed.

36. A patch according to claim 28 wherein said target is flexible so as to permit said patch to adapt and conform to the contour of said surface region.

37. A patch according to claim 28 wherein said target and said maintaining means are adapted to be disposable and are fashioned of essentially biodegradable materials.

38. A patch adapted for placement proximate to a surface region of a mammal, said patch including:

a. an infrared target for receiving thermal energy from said surface region and for emitting infrared radiation according to a substantially known emissivity property whereby, when said target is placed proximate to said surface region, the characteristics of infrared radiation emitted by said target substantially correspond to the temperature of said surface region; and

b. indicia uniquely associated with said patch.

39. A patch according to claim 38 wherein indicia is essentially visible to the human eye.
40. A patch according to claim 38 wherein said indicia is essentially invisible to the human eye.
41. A patch according to claim 38 wherein said indicia is selected from the group consisting of a bar code or other pattern adapted to be recognized by a machine, an RFID device, a photodiode, a magnetic medium, and physical deformation of a portion of the patch.
42. A patch according to claim 38 wherein said patch includes a bio-reactive agent having a characteristic that is capable of being detectively altered in the presence of a pre-selected bio-chemical property of said surface region.
43. A patch according to claim 42 wherein said property is essentially the pH value of said surface region.
44. A patch according to claim 42 wherein said bio-reactive agent characteristic is capable of being altered in a manner detectable through spectroscopy.
45. A patch according to claim 38 further including indicia uniquely associated with a particular location on the mammal where said patch is to be placed.
46. A patch according to claim 38 wherein said target is flexible so as to permit said patch to adapt and conform to the contour of said surface region.
47. A patch according to claim 38 wherein said target is adapted to be disposable and is fashioned of essentially biodegradable material.
48. A method of monitoring the body temperature of a mammal, comprising:

a. providing at least one patch, each of said at least one patches including (1) an infrared target for receiving thermal energy from a surface region of the mammal and for emitting infrared radiation according to a substantially known emissivity property whereby, when said target is placed proximate to a said surface region, the characteristics of an infrared radiation emitted by said target substantially correspond to the temperature of said surface region, and (2) an insulator for protecting said target from thermal effects of media adjacent to, but different from, said surface region;

b. placing at least one of said patches proximate to a respective associated surface region of the mammal;

c. providing at least one infrared thermometer adapted to sense infrared radiation emitted by said target of at least one of said at least one patches; and

d. repeatedly using said at least one thermometer to sense infrared radiation emitted by said target of at least one of said at least one patches and to correlate said sensed infrared radiation to an associated temperature.

49. A method of monitoring according to claim 48, further comprising:

sequentially recording the associated temperatures obtained from using said at least one thermometer such that a trend of the body temperature of the mammal is maintained.

50. A method of monitoring according to claim 48 wherein in step (b) at least two of said patches are each placed proximate to a respective associated surface of the mammal.

51. A method of monitoring according to claim 48 further comprising wirelessly transmitting either information about the infrared radiation sensed by said at least one

thermometer or information about said associated temperature to a remote location where said sequentially recording occurs.

52. A method of monitoring the body temperature of a mammal, comprising:

a. providing at least one patch, each of said at least one patches including (1) an infrared target for receiving thermal energy from a surface region of the mammal and for emitting infrared radiation according to a substantially known emissivity property whereby, when said target is placed proximate to a said surface region, the characteristics of an infrared radiation emitted by said target substantially correspond to the temperature of said surface region, (2) means for selectively maintaining said target in a position proximate to a surface region of a mammal, and (3) indicia uniquely associated with said patch;

b. placing at least one of said patches proximate to a respective associated surface region of the mammal;

c. providing at least one infrared thermometer adapted to sense infrared radiation emitted by said target of at least one of said at least one patches; and

d. repeatedly using said at least one thermometer to sense infrared radiation emitted by said target of at least one of said at least one patches and to correlate said sensed infrared radiation to an associated temperature.

53. A method of monitoring according to claim 52, further comprising:

sequentially recording the associated temperatures obtained from using said at least one thermometer such that a trend of the body temperature of the mammal is maintained.

54. A method of monitoring according to claim 52 wherein in step (b) at least two of said patches are each placed proximate to a respective associated surface of the mammal.

55. A method of monitoring according to claim 52 further comprising wirelessly transmitting either information about the infrared radiation sensed by said at least one thermometer or information about said associated temperature to a remote location where said sequentially recording occurs.

56. A method of monitoring the body temperature of a mammal, comprising:

a. providing at least one patch, each of said at least one patches including (1) an infrared target for receiving thermal energy from a surface region of the mammal and for emitting infrared radiation according to a substantially known emissivity property whereby, when said target is placed proximate to a said surface region, the characteristics of an infrared radiation emitted by said target substantially correspond to the temperature of said surface region, and (2) indicia uniquely associated with said patch;

b. placing at least one of said patches proximate to a respective associated surface region of the mammal;

c. providing at least one infrared thermometer adapted to sense infrared radiation emitted by said target of at least one of said at least one patches; and

d. repeatedly using said at least one thermometer to sense infrared radiation emitted by said target of at least one of said at least one patches and to correlate said sensed infrared radiation to an associated temperature.

57. A method of monitoring according to claim 56, further comprising:

sequentially recording the associated temperatures obtained from using said at least one thermometer such that a trend of the body temperature of the mammal is maintained.

58. A method of monitoring according to claim 56 wherein in step (b) at least two of said patches are each placed proximate to a respective associated surface of the mammal.

59. A method of monitoring according to claim 56 further comprising wirelessly transmitting either information about the infrared radiation sensed by said at least one thermometer or information about said associated temperature to a remote location where said sequentially recording occurs.

60. A method of monitoring the body temperature associated with each of at least two mammals, comprising:

a. providing at least two patches, each of said at least two patches including (1) an infrared target for receiving thermal energy from a surface region of the mammal and for emitting infrared radiation according to a substantially known emissivity property whereby, when said target is placed proximate to said surface region, the characteristics of infrared radiation emitted by said target substantially correspond to the temperature of said surface region, and (2) indicia uniquely associated with said patch;

b. placing at least one of said patches proximate to a respective associated surface region of each one of the mammals;

c. providing at least one infrared thermometer adapted to sense infrared radiation emitted by said target of said at least one of said at least two patches on each one of the mammals;

d. repeatedly using said at least one thermometer to sense infrared radiation emitted by said target of said at least two patches placed proximate to a respective associated surface region of each of the mammals and to correlate said sensed infrared radiation to an associated temperature; and

e. correlating the indicia uniquely associated with each of said at least two patches with the associated temperature obtained from using said at least one thermometer to sense infrared radiation emitted from said target of said associated patch placed proximate to a respective associated surface region of each of the mammals.

61. A method of monitoring according to claim 60 further comprising:

sequentially recording the associated temperatures obtained from using said at least one thermometer such that a trend of the body temperature of each one of the mammals is maintained.

62. A method of monitoring according to claim 60 further comprising wirelessly transmitting either information about the infrared radiation sensed by said at least one thermometer or information about said associated temperature to a remote location where said sequentially recording occurs.

63. A method of using a medium having a substantially known infrared emissivity property to determine the body temperature of a mammal comprising:

- a. placing said medium proximate to a surface region of the mammal;
- b. sensing the infrared radiation emitted from said medium; and
- c. correlating said sensed infrared radiation with an associated temperature.

64. A method of using a medium according to claim 63 wherein said medium possesses a substantially wafer shape having a surface adapted to conform with the

contour of the surface region and wherein said medium is placed such that said medium surface is disposed conformingly proximate to the surface region.

65. A method of using a medium according to claim 63 wherein said medium also has an associated bio-reactive agent possessing a characteristic that is capable of being detectively altered in the presence of a pre-selected bio-chemical property of the surface region and wherein the method further comprises:

detecting an alteration of the agent.

66. A method of using a medium having a substantially known infrared emissivity property to determine the body temperature of a mammal comprising:

- a. step for placing said medium proximate to a surface region of the mammal;
- b. step for sensing the infrared radiation emitted from said medium; and
- c. step for correlating said sensed infrared radiation with an associated temperature.

67. A method of using a medium according to claim 66 wherein said medium possesses a substantially wafer shape having a surface adapted to conform with the contour of the surface region and wherein said medium is placed such that said medium surface is disposed conformingly proximate to the surface region.

68. A method of using a medium according to claim 66 wherein said medium also has an associated bio-reactive agent possessing a characteristic that is capable of being detectively altered in the presence of a pre-selected bio-chemical property of the surface region and wherein the method further comprises:

step for detecting an alteration of the agent.

69. A method of monitoring the body temperature of a mammal, comprising:

a. providing at least one patch, each of said at least one patches including an infrared target for receiving thermal energy from a surface region of the mammal and for emitting infrared radiation according to a substantially known emissivity property whereby, when said target is placed proximate to a said surface region, the characteristics of an infrared radiation emitted by said target substantially correspond to the temperature of said surface region;

b. placing at least one of said patches proximate to a respective associated surface region of the mammal;

c. providing at least one infrared thermometer adapted to sense infrared radiation emitted by said target of at least one of said at least one patches; and

d. repeatedly using said at least one thermometer to sense infrared radiation emitted by said target of at least one of said at least one patches and to correlate said sensed infrared radiation to an associated temperature.

70. A method of monitoring according to claim 69, further comprising:

sequentially recording the associated temperatures obtained from using said at least one thermometer such that a trend of the body temperature of the mammal is maintained.

71. A method of monitoring according to claim 70 wherein in step (b) at least two of said patches are each placed proximate to a respective associated surface of the mammal.

72. A method of monitoring according to claim 70 further comprising wirelessly transmitting either information about the infrared radiation sensed by said at least one thermometer or information about said associated temperature to a remote location where said sequentially recording occurs.

73. A method of monitoring the body temperature associated with each of at least two mammals, comprising:

a. providing at least two patches, each of said at least two patches including an infrared target for receiving thermal energy from a surface region of the mammal and for emitting infrared radiation according to a substantially known emissivity property whereby, when said target is placed proximate to said surface region, the characteristics of infrared radiation emitted by said target substantially correspond to the temperature of said surface region;

b. placing each of said at least two patches proximate to a respective associated surface region of an associated one of the at least two mammals;

c. providing at least one infrared thermometer adapted to sense infrared radiation emitted by said target of each of said at least two patches when said patches are placed proximate to a respective associated surface region of the associated mammal; and

d. repeatedly using said at least one thermometer to sense infrared radiation emitted by said target of said at least two patches when said patches are placed proximate to a respective associated surface region of the associated mammal and to correlate said sensed infrared radiation to an associated temperature.

74. A method of monitoring according to claim 73 further comprising:

sequentially recording the associated temperatures obtained from using said at least one thermometer such that a trend of the body temperature of each one of the mammals is maintained.

75. A method of monitoring according to claim 73 further comprising wirelessly transmitting either information about the infrared radiation sensed by said at least one

thermometer or information about said associated temperature to a remote location where said sequentially recording occurs.

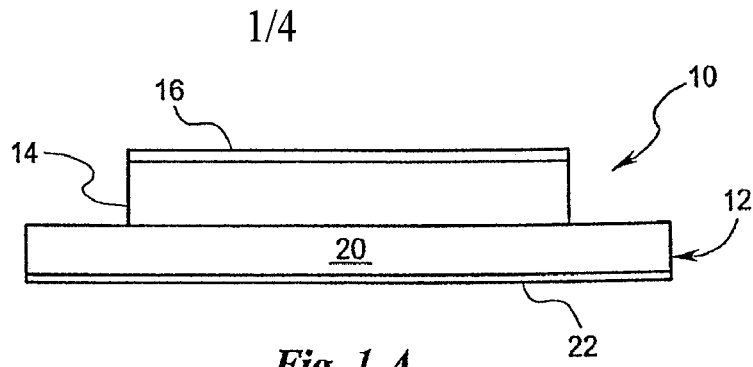

Fig. 1-A

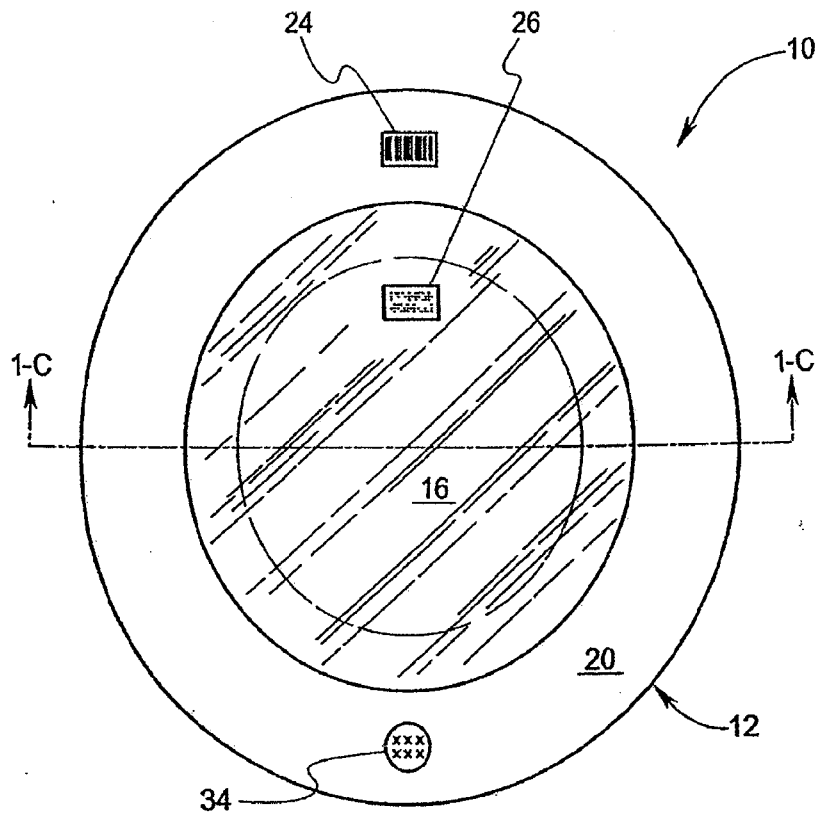

Fig. 1-B

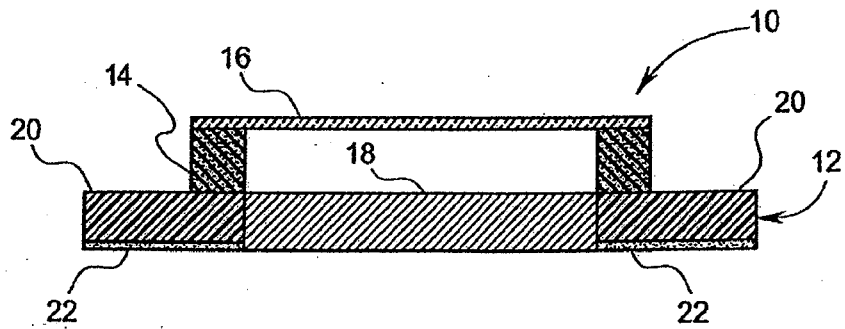
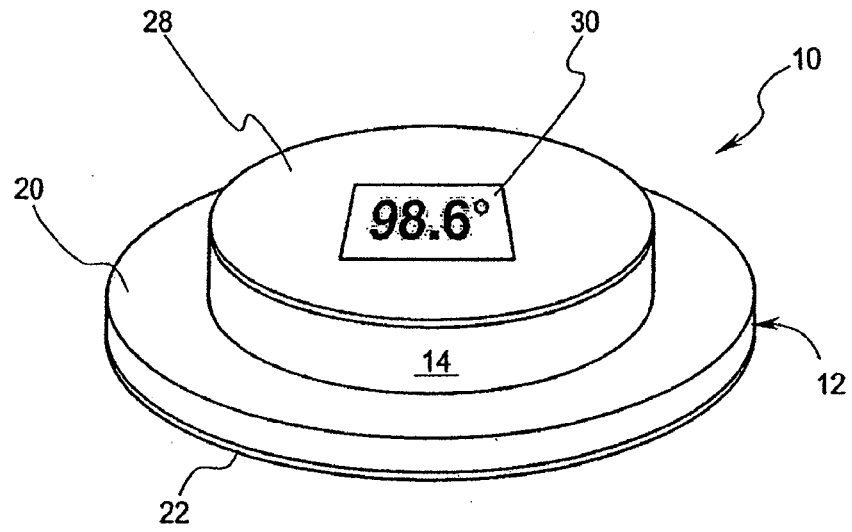
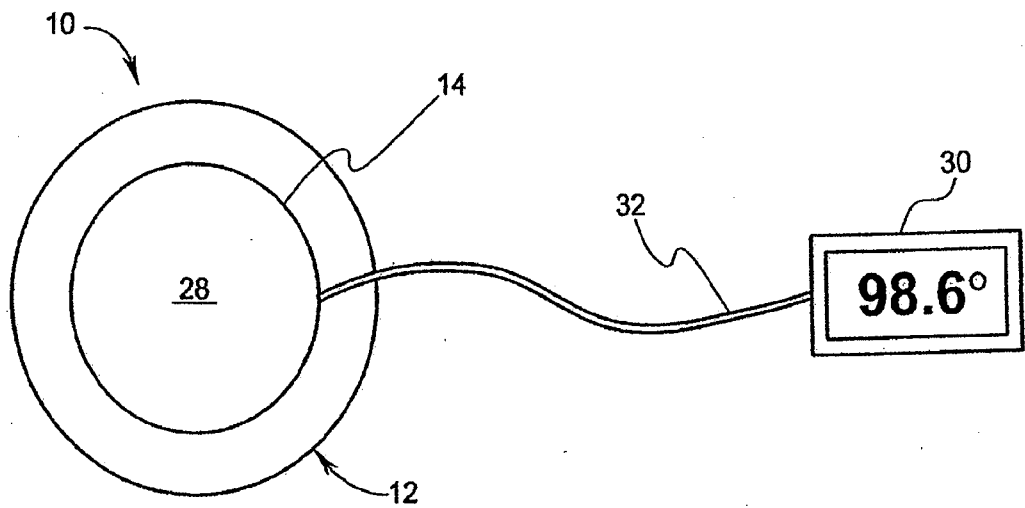

Fig. 1-C



**Fig. 2**



**Fig. 3**

<b>Patient Name:</b>	Joseph Smith			
<b>Patient ID#:</b>	ACX2341			
<b>Patient Birth Date:</b>	09/22/41			
<b>Patient Sex:</b>	Male			
<b>Temperature Patches:</b>	1. Under right bicep 2. Inner left thigh 3. None			
<b>Bioreactive Agents:</b>	1. None 2. None			
<b>Last Readings</b>				
<b>Date</b>	<b>Time</b>	<b>Nurse ID</b>	<b>Temperature</b>	<b>Bioreactive</b>
03/07/07	16:34	B67	1. 98.2F 2. 98.9F 3. —	1. — 2. —
03/07/07	13:21	B22	1. 98.6F 2. 99.0F 3. —	1. — 2. —
03/07/07	10:18	B31	1. 98.8F 2. 98.6F 3. —	1. — 2. —
<b>Current Nurse ID: B67</b>				
<b>Current Date and Time: 03/07/07 19:40</b>				

*Fig. 4*

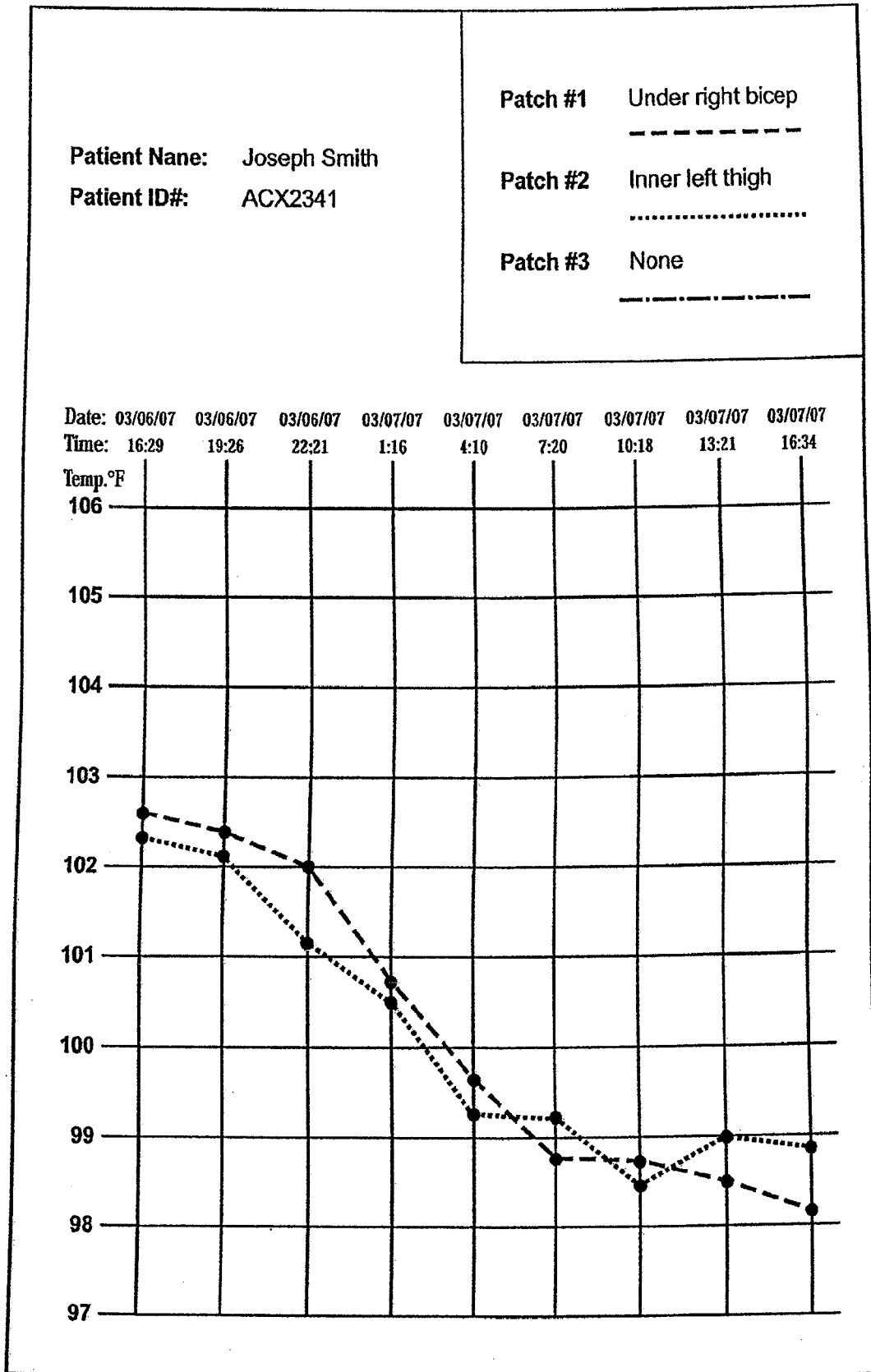

Fig. 5

# INTERNATIONAL SEARCH REPORT

International application No.  
**PCT/US2008/068004**

**A. CLASSIFICATION OF SUBJECT MATTER**  
  
*A61B 5/04(2006.01)i, A61B 5/00(2006.01)i, G01K 13/00(2006.01)i*  
  
According to International Patent Classification (IPC) or to both national classification and IPC

**B. FIELDS SEARCHED**  
  
Minimum documentation searched (classification system followed by classification symbols)  
IPC 8: A61B 5/00

Documentation searched other than minimum documentation to the extent that such documents are included in the fields searched  
Korean utility models and applications for utility models since 1975.  
Japanese utility models and applications for utility models since 1975.

Electronic data base consulted during the international search (name of data base and, where practicable, search terms used)  
eKIPASS(KIPO internal)  
Keywords: Infrared, temperature, patch, thermometer



**C. DOCUMENTS CONSIDERED TO BE RELEVANT**

Category*	Citation of document, with indication, where appropriate, of the relevant passages	Relevant to claim No.
A	US 7187960 B2 (ABREU, M. M.) 06 March 2007 See figure 16C and claim 1	1-75
A	US 6629776 B2 (BELL, F. G. et al.) 07 October 2003 See claim 1 and claim 34	1-75
A	US 6751497 B2 (FRADEN, J.) 15 June 2004 See figure 1 and claim 1	1-75
A	US 5340215 A (MAKITA, S. et al.) 23 August 1994 See abstract and claim 1	1-75

Further documents are listed in the continuation of Box C.       See patent family annex.

<p>* Special categories of cited documents:                  "A" document defining the general state of the art which is not considered to be of particular relevance                  "E" earlier application or patent but published on or after the international filing date                  "L" document which may throw doubts on priority claim(s) or which is cited to establish the publication date of citation or other special reason (as specified)                  "O" document referring to an oral disclosure, use, exhibition or other means                  "P" document published prior to the international filing date but later than the priority date claimed</p>	<p>"T" later document published after the international filing date or priority date and not in conflict with the application but cited to understand the principle or theory underlying the invention                  "X" document of particular relevance; the claimed invention cannot be considered novel or cannot be considered to involve an inventive step when the document is taken alone                  "Y" document of particular relevance; the claimed invention cannot be considered to involve an inventive step when the document is combined with one or more other such documents, such combination being obvious to a person skilled in the art                  "&amp;" document member of the same patent family</p>
---	---

Date of the actual completion of the international search <p style="text-align: center;">20 JANUARY 2009 (20.01.2009)</p>	Date of mailing of the international search report <p style="text-align: center;"><b>20 JANUARY 2009 (20.01.2009)</b></p>
--	--

<p>Name and mailing address of the ISA/KR</p>  <p>Korean Intellectual Property Office Government Complex-Daejeon, 139 Seonsa-ro, Seo-gu, Daejeon 302-701, Republic of Korea</p> <p>Facsimile No. 82-42-472-7140</p>	<p>Authorized officer</p> <p style="text-align: center;">KIM, KEON HYEONG</p> <p>Telephone No. 82-42-481-8509</p> 
--	---

**INTERNATIONAL SEARCH REPORT**

Information on patent family members

International application No.

**PCT/US2008/068004**

Patent document cited in search report	Publication date	Patent family member(s)	Publication date
US 7187960 B2	06.03.2007	US 2004-0059212 A1	25.03.2004
US 6629776 B2	07.10.2003	US 2002-0105436 A1	08.08.2002
US 6751497 B2	15.06.2004	EP 0964231 A2	15.12.1999
		EP 0964231 A3	01.03.2000
		US 2002-0123690 A1	05.09.2002
		US 6129673 A	10.10.2000
US 5340215 A	23.08.1994	DE 69122973 D1	05.12.1996
		DE 69122973 T2	12.06.1997
		EP 0567646 A1	03.11.1993
		EP 0567646 B1	30.10.1996
		JP 4242631 A	31.08.1992
		KR 10-1993-0702919	29.11.1993
		KR 9615435 B1	14.11.1996
		SG 47705 A1	17.04.1998
		US 5340215 A	23.08.1994
		WO 92-11800 A1	23.07.1992

专利名称(译)	温度贴片及其使用方法		
公开(公告)号	<a href="#">EP2211706A1</a>	公开(公告)日	2010-08-04
申请号	EP2008771811	申请日	2008-06-24
[标]申请(专利权)人(译)	伟伦公司		
申请(专利权)人(译)	伟伦 , INC.		
当前申请(专利权)人(译)	伟伦 , INC.		
[标]发明人	QUINN DAVID E MARTIN SCOTT A LANE JOHN A MEYERSON CRAIG M CORCORAN CLARE L		
发明人	QUINN, DAVID, E. MARTIN, SCOTT, A. LANE, JOHN, A. MEYERSON, CRAIG, M. CORCORAN, CLARE, L.		
IPC分类号	A61B5/04 A61B5/00 G01K13/00		
CPC分类号	A01K29/005 A61B5/01 A61B5/6833 A61B2562/164 A61D17/002 G01J5/0022 G01J5/0025 G01J5/02 G01J5/025 G01J5/08 G01J5/0893 G01K1/083 G01K1/18 G01K13/002		
代理机构(译)	HAUCK专利和律师		
优先权	11/873046 2007-10-16 US		
其他公开文献	EP2211706A4		
外部链接	<a href="#">Espacenet</a>		

#### 摘要(译)

具有红外 ( IR ) 靶的贴片被放置在哺乳动物的表面附近。贴片可以包括用于保护目标免于外部环境IR的绝缘体，并且可以包括与贴片或哺乳动物唯一相关的条形码或其他标记。贴片还可以包括用于指示诸如哺乳动物皮肤的pH的特征的生物反应剂。贴片还可以包括用于感测来自IR目标的IR辐射的水平温度计，并且可以包括与这样的水平相关联的温度的显示。该补丁还可以包括用于将关于这样的级别的信息无线地传送到远程位置的发送器。还公开了使用贴片的方法。