

(19) World Intellectual Property Organization
International Bureau



(43) International Publication Date
12 April 2007 (12.04.2007)

PCT

(10) International Publication Number
WO 2007/041296 A1

(51) International Patent Classification:
A61B 5/00 (2006.01)

(21) International Application Number:
PCT/US2006/038064

(22) International Filing Date:
29 September 2006 (29.09.2006)

(25) Filing Language: English

(26) Publication Language: English

(30) Priority Data:
11/241,375 29 September 2005 (29.09.2005) US

(71) Applicant (for all designated States except US): **NELL-COR PURITAN BENNETT INCORPORATED** [US/US]; 4280 Hacienda Drive, Pleasanton, CA 94588 (US).

(72) Inventors; and

(75) Inventors/Applicants (for US only): **HOARAU, Carine** [US/US]; 3164 Rohrer Drive, Lafayette, CA 94549 (US). **BAKER, Clark, R.** [US/US]; 18493 Magee Way, Castro Valley, CA 94546 (US). **KARST, Edward** [US/US]; 1616 Fair Oaks Avenue, Apt. 11, South Pasadena, CA 91030 (US).

(74) Agent: **SLAYDEN, Bruce, W.**; BAKER BOTTS L.L.P., 1500 San Jacinto Center, 98 San Jacinto Blvd., Austin, TX 78701 (US).

(81) Designated States (unless otherwise indicated, for every kind of national protection available): AE, AG, AL, AM,

AT, AU, AZ, BA, BB, BG, BR, BW, BY, BZ, CA, CH, CN, CO, CR, CU, CZ, DE, DK, DM, DZ, EC, EE, EG, ES, FI, GB, GD, GE, GH, GM, HN, HR, HU, ID, IL, IN, IS, JP, KE, KG, KM, KN, KP, KR, KZ, LA, LC, LK, LR, LS, LT, LU, LV, LY, MA, MD, MG, MK, MN, MW, MX, MY, MZ, NA, NG, NI, NO, NZ, OM, PG, PH, PL, PT, RO, RS, RU, SC, SD, SE, SG, SK, SL, SM, SV, SY, TJ, TM, TN, TR, TT, TZ, UA, UG, US, UZ, VC, VN, ZA, ZM, ZW.

(84) Designated States (unless otherwise indicated, for every kind of regional protection available): ARIPO (BW, GH, GM, KE, LS, MW, MZ, NA, SD, SL, SZ, TZ, UG, ZM, ZW), Eurasian (AM, AZ, BY, KG, KZ, MD, RU, TJ, TM), European (AT, BE, BG, CH, CY, CZ, DE, DK, EE, ES, FI, FR, GB, GR, HU, IE, IS, IT, LT, LU, LV, MC, NL, PL, PT, RO, SE, SI, SK, TR), OAPI (BF, BJ, CF, CG, CI, CM, GA, GN, GQ, GW, ML, MR, NE, SN, TD, TG).

Declarations under Rule 4.17:

- as to applicant's entitlement to apply for and be granted a patent (Rule 4.17(ii))
- as to the applicant's entitlement to claim the priority of the earlier application (Rule 4.17(iii))

Published:

- with international search report
- before the expiration of the time limit for amending the claims and to be republished in the event of receipt of amendments

For two-letter codes and other abbreviations, refer to the "Guidance Notes on Codes and Abbreviations" appearing at the beginning of each regular issue of the PCT Gazette.

(54) Title: MEDICAL SENSOR

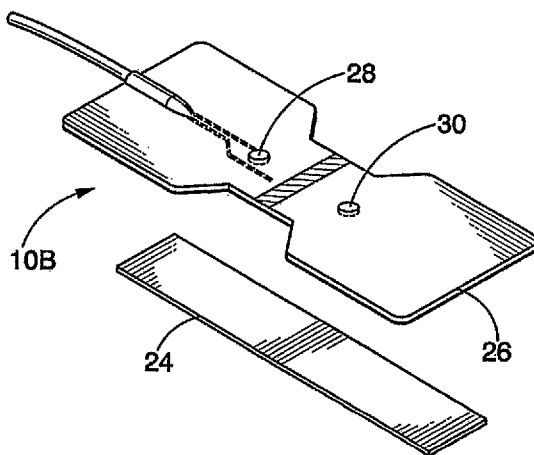

(57) Abstract: A sensor for pulse oximetry or other applications utilizing spectrophotometry may be adapted to reduce motion artifacts by fixing the optical distance between an emitter and detector. A flexible sensor is provided with a stiffening member to hold the emitter and detector of the sensor in a relatively fixed position when applied to a patient. Further, an annular or partially annular sensor is adapted to hold an emitter and detector of the sensor in a relatively fixed position when applied to a patient. A clip-style sensor is provided with a spacer that controls the distance between the emitter and detector.

WO 2007/041296 A1

MEDICAL SENSOR

BACKGROUND OF THE INVENTION

1. Field Of The Invention

5 The present invention relates generally to medical devices and, more particularly, to sensors used for sensing physiological parameters of a patient.

2. Description Of The Related Art

10 This section is intended to introduce the reader to various aspects of art that may be related to various aspects of the present invention, which are described and/or claimed below. This discussion is believed to be helpful in providing the reader with background information to facilitate a better understanding of the various aspects of the present invention. Accordingly, it should be understood that these statements are to be read in this light, and not as admissions of prior art.

15 In the field of medicine, doctors often desire to monitor certain physiological characteristics of their patients. Accordingly, a wide variety of devices have been developed for monitoring many such characteristics of a patient. Such devices provide doctors and other healthcare personnel with the information they need to provide the best possible healthcare for their patients. As a result, such monitoring devices have become an indispensable part of modern medicine.

20 One technique for monitoring certain physiological characteristics of a patient is commonly referred to as pulse oximetry, and the devices built based upon pulse oximetry techniques are commonly referred to as pulse oximeters. Pulse oximetry may be used to measure various blood flow characteristics, such as the blood-oxygen saturation of hemoglobin in arterial blood, the volume of individual blood pulsations supplying the tissue, and/or the rate of blood pulsations corresponding to each heartbeat of a patient. In fact, the "pulse" in pulse oximetry refers to the time varying amount of arterial blood in the tissue during each cardiac cycle.

25 Pulse oximeters typically utilize a non-invasive sensor that transmits electromagnetic radiation, such as light, through a patient's tissue and that photoelectrically

detects the absorption and scattering of the transmitted light in such tissue. One or more of the above physiological characteristics may then be calculated based upon the amount of light absorbed and scattered. More specifically, the light passed through the tissue is typically selected to be of one or more wavelengths that may be absorbed and scattered by the blood in an amount correlative to the amount of the blood constituent present in the tissue. The measured amount of light absorbed and scattered may then be used to estimate the amount of blood constituent in the tissue using various algorithms.

Pulse oximetry readings measure the pulsatile, dynamic changes in amount and type of blood constituents in tissue. Other events besides the pulsing of arterial blood may lead to modulation of the light path, direction, and the amount of light detected by the sensor, creating error in these measurements. Pulse oximetry is sensitive to movement, and various types of motion may cause artifacts that may obscure the blood constituent signal. For example, motion artifacts may be caused by moving a sensor in relation to the tissue, by increasing or decreasing the physical distance between emitters and detectors in a sensor, by changing the direction of emitters or detectors with respect to tissue or each other, by changing the angles of incidence and interfaces probed by the light, by directing the optical path through different amounts or types of tissue, or by expanding, compressing or otherwise altering tissue near a sensor. In the emergency room, critical care, intensive care, and trauma center settings, where pulse oximetry is commonly used for patient monitoring, the wide variety of sources of motion artifacts includes moving of a patient or the sensor by healthcare workers, physical motion of an unanaesthetised or ambulatory patient, shivering, seizures, agitation, response to pain and loss of neural control. These motions oftentimes have similar frequency content to the pulse, and may lead to similar or even larger optical modulations than the pulse.

Two categories of pulse oximetry sensors in common use may be classified by their pattern of use: the disposable and the reusable sensor. Disposable sensors are typically flexible bandage-type structures that may be attached to the patient with adhesive materials, providing a contact between the patient's skin and the sensor components. Disposable sensors have multiple advantages, including ease of conformation to the patient. The flexible nature of disposable sensors further renders them susceptible to motion artifacts caused by mechanical deformation of the sensor, which

changes the amount of light detected. Reusable sensors, often semi-rigid or rigid clip-type devices, are also vulnerable to motion artifacts, such as artifacts caused by partial opening of the clip in response to patient motion. Both categories of sensors may have modulations of detected light induced by the physical motion of the sensor components with respect to each other and the tissue.

Motion artifacts may sometimes be addressed by signal processing and filtering to mitigate the effects of motion after the motion has occurred. However, it would be desirable to provide a sensor that reduces the occurrence of movement that may lead to motion artifacts.

SUMMARY

Certain aspects commensurate in scope with the originally claimed invention are set forth below. It should be understood that these aspects are presented merely to provide the reader with a brief summary of certain forms of the invention might take and that these aspects are not intended to limit the scope of the invention. Indeed, the invention may encompass a variety of aspects that may not be set forth below.

There is provided a sensor that includes a sensor body, and an emitter and a detector disposed on the sensor body. The sensor body is adapted to hold the emitter and detector at a substantially fixed optical distance relative to one another when the sensor is applied to a patient.

There is also provided a pulse oximetry system that includes a pulse oximetry monitor and a pulse oximetry sensor adapted to be operatively coupled to the monitor. The sensor includes a sensor body, and an emitter and a detector disposed on the sensor body. The sensor body is adapted to hold the emitter and detector at a substantially fixed optical distance relative to one another when the sensor is applied to a patient.

There is also provided a method of operating a sensor that includes fixing the optical distance between an emitter and a detector relative to one another, whereby the emitter and the detector are disposed on a sensor body.

There is also provided a method of manufacturing a sensor that includes providing a sensor body on which an emitter and a detector are disposed, whereby the sensor body is adapted to hold the emitter and the detector at a fixed optical distance.

BRIEF DESCRIPTION OF THE DRAWINGS

Advantages of the invention may become apparent upon reading the following detailed description and upon reference to the drawings in which:

Fig. 1 illustrates a perspective view of an exemplary bandage-style pulse oximetry sensor with a stiffening member on the tissue-contacting side of the sensor body;

Fig. 2 illustrates a perspective view of an exemplary bandage-style pulse oximetry sensor with a brass stiffening member applied to the surface of the sensor body that does not contact a patient's tissue during normal use;

Fig. 3A illustrates a view showing the interior of an exemplary bandage-style pulse oximetry sensor with an embedded stiffening member;

Fig. 3B illustrates a perspective view of an exemplary bandage-style pulse oximetry sensor with an embedded, removable stiffening member;

Fig. 4A illustrates a view showing the interior of an exemplary reflectance bandage-style pulse oximetry sensor with an embedded stiffening member including a rigid portion that surrounds the emitter and the detector and a flexible portion;

Fig. 4B illustrates a view showing an exemplary reflectance bandage-style pulse oximetry sensor with a stiffening member surrounding the emitter and detector;

Fig. 4C illustrates a perspective view of an exemplary reflectance bandage-style pulse oximetry sensor with a rigid portion that surrounds the emitter and the detector and an embedded, removable stiffening member that is flexible;

Fig. 5A illustrates a perspective view of an exemplary bandage-style pulse oximetry sensor with a fluid-filled chamber;

Fig. 5B illustrates a perspective view of the pulse oximetry sensor of Fig. 5A in which the fluid-filled chamber includes a valve;

Fig. 6 illustrates a perspective view of an exemplary bandage-style pulse oximetry sensor with two fluid-filled chambers separated by a breakable barrier;

Fig. 7 illustrates a perspective view of an exemplary pulse oximetry sensor according to the present invention with a removable rigid sleeve;

Fig. 8A illustrates a perspective view of an exemplary annular pulse oximetry sensor according to the present invention;

Fig. 8B illustrates a perspective view of the pulse oximetry sensor of Fig. 8A with an adjustment strap;

Fig. 9 illustrates an embodiment of an exemplary partially annular pulse oximetry sensor according to the present invention;

5 Fig. 10 illustrates a cross-sectional view of an exemplary clip-style pulse oximetry sensor with a spacer that moves to adjust the distance between the two portions of the clip;

Fig. 11A illustrates a cross-sectional view of an exemplary clip-style pulse oximetry sensor with a removable spacer according to the present invention;

10 Fig. 11B is a perspective view of the removable spacer of Fig. 11A;

Fig. 12 illustrates a perspective view of an exemplary clip-style pulse oximetry sensor in which the two portions of the clip are adjusted with a sliding pin; and

Fig. 13 illustrates a pulse oximetry system coupled to a multi-parameter patient monitor and a sensor according to embodiments of the present invention.

15

DETAILED DESCRIPTION OF SPECIFIC EMBODIMENTS

One or more specific embodiments of the present invention will be described below. In an effort to provide a concise description of these embodiments, not all features of an actual implementation are described in the specification. It should be appreciated that in the development of any such actual implementation, as in any engineering or design project, numerous implementation-specific decisions must be made to achieve the developers' specific goals, such as compliance with system-related and business-related constraints, which may vary from one implementation to another. Moreover, it should be appreciated that such a development effort might be complex and time consuming, but would nevertheless be a routine undertaking of design, fabrication, and manufacture for those of ordinary skill having the benefit of this disclosure.

25 In accordance with the present technique, sensors for pulse oximetry or other applications utilizing spectrophotometry are provided that reduce motion artifacts by fixing the optical distance between an emitter and a detector when the sensor is applied to a patient. For example, in one embodiment, a conformable sensor is provided that has a stiffening member adapted to hold the emitter and detector at a fixed optical distance

30

when the sensor is applied to a patient. In another embodiment, an annular or partially annular sensor is provided that maintains a fixed optical distance between an emitter and a detector when the sensor is applied to a patient's digit. Further, in an additional embodiment, a clip-style sensor is provided that holds the emitter and detector at a fixed optical distance.

Motion artifacts in pulse oximetry are often generated by the movement of the pulse oximetry sensor relative to the optically probed tissue, which is typically caused by patient movement. Because pulse oximetry is often used in settings where it is difficult to prevent patient motion, it is desirable to provide a mechanism for reducing the effects of motion on the pulse oximetry measurement. Generally, sensors are vulnerable to motion artifacts when the optical distance between a sensor's emitter and detector varies due to an undesired mechanical change in the conformation of the sensor while in use.

A change in optical distance may include any change in position or geometry of the emitter and/or the detector relative to the tissue or relative to each other. More specifically, a change in optical distance may involve a change in the path length, a change in the angle of the emitter or detector relative to one another, and/or a change in the angle of the emitter or detector relative to the tissue. For example, a tapping or pressing motion by a patient may serve to compress a flexible bandage sensor, decreasing the path length between the emitter and detector. Alternatively, a tapping or pressing motion may partially open a clip-type sensor through pressure on the clip spring, thus increasing the path length between the emitter and detector. For both a bandage and a clip-style sensor, a jerking or flexing motion may separate the emitter and detector, thus increasing the optical path length. Additionally, any of the above motions may twist or bend the sensor, causing the angle of the emitter and/or the detector to change relative to the sensor and each other. As sensors do not typically emit nor detect light omnidirectionally; any motions that lead to variations in angle of sensor components may alter the amount of light detected, and may force detected light through different portions of tissue. In any case, variability in the optical path length due to motion can cause motion artifacts and obscure the desired pulse oximetry signal. Thus, it is desirable that a sensor's emitter and detector are held at a substantially fixed optical distance with respect to one another.

By holding a sensor's emitter and detector at a substantially fixed optical position with respect to one another, the sensors provided herein limit the modulations of detected light that may occur and the resulting measurement errors. These sensors substantially reduce the occurrence of motion artifacts by reducing the change in position of the sensing components of the sensor with respect to each other and the tissue.

Keeping in mind the preceding points, the following exemplary sensor designs are provided as examples of sensors that reduce motion artifacts by maintaining a fixed optical distance between an emitter and a detector of a sensor 10. It should be appreciated that a sensor 10 according to the present teachings may be adapted for use on any digit, and may also be adapted for use on a forehead, earlobe, or other sensor site. For example, a sensor 10 may be a clip-style sensor, appropriate for a patient earlobe or digit. Alternatively, a sensor 10 may be a bandage-style or wrap-style sensor for use on a digit or forehead. Further, it should be appreciated that a sensor 10 may also include adhesives to facilitate securing of the sensing elements to the tissue. In certain embodiments, the adhesives may include an adhesive coating on the tissue-contacting surface of the sensor 10.

In accordance with some embodiments of the present technique, sensors for pulse oximetry or other applications utilizing spectrophotometry are provided having a stiffening member to reduce variability in the optical distance between an emitter and a detector. For example, Fig. 1A illustrates an exemplary transmission-type bandage sensor appropriate for use on a patient digit. As shown in Fig. 1A, a sensor 10A may have a stiffening member 12 that is applied to a conformable sensor body 14. The stiffening member 12 may be applied to a tissue-contacting surface 16, adhesively or otherwise. As the stiffening member 12 may come into contact with a patient's tissue, it may be generally constructed to have no sharp edges in order to avoid patient discomfort. The stiffening member 12 may have windows or other openings (not shown) suitably sized to accommodate an emitter 18 and a detector 20. The stiffening member 12 may be applied such that the windows or openings are in-line with the emitter and the detector to allow for normal light emitting and photodetecting function. The sensor 10A may optionally include an optically transparent adhesive layer 22 for affixing the sensor to the digit. The adhesive layer 22 may be generally sized and shaped to cover the tissue-contacting surface

16 of the conformable sensor body 22. When the sensor 10A is applied to a patient's digit, the stiffening member is bent or otherwise shaped to conform to the digit. The sensor 10A is applied such that the emitter 18 and the detector 20 lie on opposing side of the digit. After application of the sensor 10A, the emitter 18 and the detector 20 are substantially resistant to movement relative to one another.

The stiffening member 12 (and stiffening members 36 and 42, below) may be constructed from any suitable material that functions to hold the emitter and the detector of a sensor at a substantially fixed optical distance when the sensor 10A is applied to a patient. For example, a suitable stiffening member 12 may be metal, plastic or polymeric, or cardboard. In certain embodiments, suitable metals include aluminum or brass. The stiffening member 12 may be in the shape of a strip, wire, or mesh that can be easily adapted for use with a conformable sensor body 14. The stiffening member 12 may be adapted to be easily bent, shaped, activated, or applied to a conformable sensor body 14 in order to hold an emitter and a detector at a substantially fixed optical distance. The stiffening member 12 may be sized to substantially cover a majority of the tissue-contacting surface 16, or for reasons related to cost or total sensor weight, may be sized to form a strip that is generally in the area surrounding the emitter 18 and the detector 20.

In certain embodiments, it may be advantageous to apply a stiffening member to a sensor surface that does not contact a patient's tissue during normal use. For example, certain patients may be sensitive to metals, and thus in certain circumstances it may be desirable to limit the amount of skin contact with a metal stiffening member. For those patients, a sensor 10B as shown in Fig. 2 may be appropriate. Fig. 2 shows an embodiment of a sensor 10B in which a brass stiffening member 24 is applied to a surface 26 that does not contact the tissue during normal use of the sensor 10B. The brass stiffening member 24 is applied to the surface 26 along an imaginary axis connecting an emitter 28 and a detector 30. When the sensor 10B is applied to a patient's digit, the brass stiffening member 24 is bent to conform to the digit without coming in contact with the patient's tissue. In an alternate embodiment (not shown), the sensor 10B is adapted to operate in reflectance mode. The emitter 28 and detector 30 are positioned on the sensor body such that they lie side-by-side when applied to a patient's digit.

In certain embodiments, a stiffening member may be integrally constructed with the conformable sensor body, or may be a separate structure. More specifically, in the embodiment shown in Fig. 3A, a sensor 10C has a closed cavity 32 within the conformable sensor body 34 into which a stiffening member 36 may be integrated or embedded. Alternatively, in certain embodiments, it may be advantageous to apply the stiffening member to the sensor at the time of use. Fig. 3B illustrates sensor 10D in which the conformable sensor body 38 has an open cavity 40 that extends along the sensor body to provide an opening into which a removable stiffening member 42 may be manually inserted at the time of application of the sensor 10D to a patient. Before the sensor 10D is discarded after use, the removable stiffening member 42 may be removed and stored for reuse. Having a removable stiffening member 42 that is reusable is not integral to the sensor 10D may decrease sensor weight for shipping and transport, and thus may provide certain cost advantages.

In an alternate embodiment shown in Fig. 4A, a sensor 10E with an embedded stiffening member 44 within a closed cavity 46 in the conformable sensor body 48 may be adapted to operate in reflectance mode, such the emitter 50 and the detector 52 lie side-by-side when the sensor is applied to a patient. The stiffening member 44 includes a rigid portion 45 disposed in the area adjacent to the emitter 50 and the detector 52 and a more flexible portion 47. Thus, when the sensor 10E is applied to a patient, the flexible portion 47 of the stiffening member 44 allows the sensor 10E to be bent around a digit while adding stability to the conformable sensor body 48. The rigid portion 45 surrounding the emitter 50 and the detector 52 may fix the geometry of sensing elements, substantially reducing their ability to move relative to one another. In an alternate embodiment, Fig. 4B illustrates reflectance sensor 10F in which the conformable sensor body 54 includes a rigid portion 57 that surrounds the emitter 60 and the detector 62. The rigid portion may be embedded in the sensor body 54, or may be disposed on the tissue-contacting surface of the sensor body 54. Fig. 4C illustrates an alternate embodiment of the sensor 10F in which the conformable sensor body 54 has an open cavity 56 that extends along the sensor body to provide an opening into which a flexible member 58 may be manually inserted at the time of application of the sensor 10F to a patient. The rigid portion 57 is separate from the removable flexible member 58. Thus, if a healthcare worker feels that

additional sensor 10F stability may be advantageous, the flexible member 58 may be inserted into the sensor 10F. When the sensor is applied to the patient, the emitter 60 and the detector 62 lie side-by-side on the same side of the tissue.

A stiffening member need not be solid, but may also be a fluid or other non-solid material that stabilizes the optical distance between an emitter and a detector. In another embodiment, Fig. 5A shows a sensor 10G in which the conformable sensor body 64 contains a bladder 66 that is adapted to hold a fluid 68. The fluid 68 may be a liquid, gel, gas, or any suitable mixture thereof. It is contemplated that the stiffening qualities of a gas or liquid may be realized by achieving a certain pressure in the bladder 66. Generally, it is contemplated that the bladder 66 should be fully inflated or mostly inflated with the fluid 68 to hold the emitter 70 and the detector 72 at a fixed optical distance. In certain embodiments, a liquid or gel may harden after a period of time. The fluid 66 described in the above embodiment may be any suitable fluid that acts to hold an emitter 70 and a detector 72 at a substantially fixed optical distance when the sensor 10G is applied to a patient's digit. In certain embodiments, the fluid may be air or other gases and gas mixtures. In other embodiments, the fluid may be water.

In certain embodiments, it may be desirable employ a gas or gas mixture for reasons related to cost, manufacturing convenience, and total sensor weight. In Fig. 5B, the sensor 10G is modified to include a valve 74 or another suitable opening or gas injection site. The sensor may be applied to a patient's digit when the valve 74 is in the closed position and the bladder 66 is substantially empty and deflated. After application of the sensor 10G to the digit, the valve 74 is opened to allow air to flow into the bladder 66, which stiffens the sensor 10G to fix the distance between the emitter 70 and the detector 72. In other embodiments, the valve 74 may be a fluid or epoxy injection site.

Another embodiment in which a fluid-containing stiffening member may be activated upon application of the sensor to a patient is illustrated in Fig. 6. Fig. 6 depicts a sensor 10H with a first chamber 78 filled with a first material 80, and second chamber 82 filled with a second material 84. A barrier 86 separates the first chamber 78 and second chamber 82. The barrier 86 is capable of being broken upon applying the sensor 82 to a patient. After the breaking of the barrier 86, the first material 80 and the second material 84 will mix and form a composition that is capable of hardening, thus stabilizing

the optical distance between the emitter 88 and detector 90. For example, the first material 80 may be cement or plaster, and the second material 84 may be water. In another embodiment, the first material 80 may be epoxy. In another embodiment, the first material 80 may be one part of a two-part epoxy in which a first part of the epoxy, such as the base, is the first materials 80, and a second part of the epoxy, such as the catalyst or hardener, is the second material 84. Two part epoxies that may be used with a sensor 10H include Loctite® 30680 (available from Henkel, Rocky Hill, CT), Blu-Mousse® (available from Parkell, Inc., Farmindale, NY), LuxaCore® Smartmix dual from DMG (available from DMG, Englewood, NJ), and Exaflex (available from GC America, Inc., Alsip, IL).

In alternate embodiments, a stiffening member may be conditionally activated when exposed to air or light, placed in contact with skin, attached to the sensor site, conformed to fit to the sensor site, subjected to a specific environmental condition (e.g. when exposed to body or room temperatures), subjected to a specific chemical reaction, programmed by software, or subjected to external force, (e.g. from the tissue being probed by the sensor). For example, a conditionally activated stiffening member may be a vacuum-packed polymer that forms a rigid precipitate upon exposure to oxygen or water vapor. In other embodiments, the stiffening member may include a light curing adhesive such as Loctite® Flashcure-4305 (available from Henkel, Rocky Hill, CT). In another embodiment, the stiffening member may include a material undergoes a chemical hardening, such a crystallization upon exposure to a crystal seed. One such material is supersaturated sodium acetate solution that is exposed to a sodium acetate crystal. Other suitable materials for forming conditionally activated stiffening members include polyurethane and polystyrene foams that, for example, may expand and stiffen upon exposure to air.

Fig. 7 illustrates an alternate embodiment of the invention in which the stiffening member is a sleeve 92 that may be applied to a sensor, generically identified as a sensor 10, in order to mechanically stabilize the distance between the emitter 94 and detector 96 after application of the sensor 10. The sleeve 94 may have interior bumps or protrusions such as foam bumpers 95, which serve to absorb shock and cushion the sensor 10 against external forces.

Although the previously discussed embodiments have described conformable sensors, it is also envisioned that similar advantages may be realized by configuring relatively rigid sensors to hold an emitter and a detector at a fixed optical distance. For example, Fig 8A shows a rigid annular sensor 10I adapted to be applied to a patient's digit. The sensor 10I is adapted to be slid onto a patient digit, and may be further secured by a bandage or adhesive. The rigidity of the sensor 10I serves to hold the emitter 98 and the detector 100 at a fixed optical distance. In another embodiment (not shown), the sensor 10G may open at a hinge and also have a latch, snap, or other closing mechanism. The annular sensor 10I may be adjusted with a strap 102, as shown in Fig. 8B, or other adjustment mechanism in order to closely conform to the digit.

Fig. 9 shows a partially annular sensor 10J that may be placed on a digit and self-secured or secured by a bandage or other means. The sensor 10J is generally at least hemi-annular in order to provide sufficient grip on the digit. An emitter 104 and a detector 106 are arranged such that, when the sensor is applied to the digit, they would be on opposite sides of the digit.

The annular or partially annular sensors (e.g. sensors 10I and 10J) may be constructed from plastic, metal, cardboard, or any other suitable resilient material. It is contemplated the sensors 10I and 10J may be sized to approximately correlate to the profile of a jewelry ring. Alternatively, the sensors 10I and 10J may be sized to approximately correlate to the size of the first finger joint, such that when a sensor 10I or 10J is applied to the digit, the fingernail region of a digit is generally covered by the sensor, but the sensor does not interfere with flexing or bending of the finger joint.

In another embodiment, a reusable clip-style sensor adapted for use on either a digit or an earlobe is provided that holds an emitter and detector at a fixed optical distance with the use of a spacer. Such a sensor adapted for use on a patient earlobe is shown in Fig. 10, which illustrates a sensor 10K having a first portion 108 and a second portion 110 that may be moved towards one another or away from one another. The first portion 108 and the second portion 110 are each able to engage a spacer 112 that is controlled by a threaded pin 114. The spacer 112 controls the distance between the first portion 88 and the second portion 110 as the threaded pin 114 moves the spacer 112 along an angled track. The first portion 108 has an emitter 116 disposed on the tissue-contacting surface

and the second portion 110 has a detector 118 disposed on the tissue-contacting surface. When the sensor 10K is applied an earlobe, the spacer 112 may be adjusted such that the sensor 10K provides a desired amount of tension to the earlobe while maintaining a fixed optical distance between the first portion 108 and the second portion 110.

5 An alternate embodiment of a clip-style sensor 10L with a spacer is depicted in Fig. 11A. As shown, a first portion 120 and a second portion 122 of the sensor 10L may be fixed in place after application to an earlobe with a removable spacer 124. The removable spacer 124 slides into a space 106 between the first portion 120 and the second portion 122 and prevents the first portion 120 and the second portion 122 from moving
10 relative to one another. As shown in Fig. 11B, the removable spacer has grooves 128 and 130 into which suitably sized regions of the first portion 120 and the second portion 122 may slide. When the first portion 120 and the second portion 122 are fixed in grooves 128 and 130, they are unable to move relative to one another. The removable spacer 124 is shown with an angled profile, but may be shaped or sized in any suitable configuration
15 that serves to hold the first portion 120 and the second portion 122 at a fixed optical distance when the spacer 124 is engaged. The removable spacer 124 may be further fixed in place magnetically (not shown).

Alternatively, in Fig. 12, a sensor 10M is illustrated in which the distance between a first portion 132 and a second portion 134 of the clip-style sensor 10M is controlled by a
20 sliding pin 136. The sliding pin 136 and the first portion 132 and the second portion 114 are partially enclosed within a housing 137. The first portion 132 and the second portion 134 have attachment slots 138 that are able to engage the sliding pin 136. Thus, when the sliding pin 136 is pulled, the first portion 132 and the second portion 134 move towards one another. When the sliding pin 136 is pushed, the first portion 132 and the second
25 portion 134 move away from one another. The first portion 132 and the second portion 134 may be adapted to house an emitter and a detector (not shown). To apply the sensor 10M to the patient, the sliding pin 136 is pushed into the housing 137 to increase the distance between the first portion 132 and the second portion 134 in order to accommodate the patient's tissue. The sliding pin 136 may then be pushed into the
30 housing 137 until the desired pressure from the sensor 10M on the patient's tissue is reached.

A sensor, illustrated generically as a sensor 10, may be used in conjunction with a pulse oximetry monitor 140, as illustrated in Fig. 13. It should be appreciated that the cable 142 of the sensor 10 may be coupled to the monitor 140 or it may be coupled to a transmission device (not shown) to facilitate wireless transmission between the sensor 10 and the monitor 140. The monitor 140 may be any suitable pulse oximeter, such as those available from Nellcor Puritan Bennett Inc. Furthermore, to upgrade conventional pulse oximetry provided by the monitor 140 to provide additional functions, the monitor 140 may be coupled to a multi-parameter patient monitor 144 via a cable 146 connected to a sensor input port or via a cable 148 connected to a digital communication port.

The sensor 10 includes an emitter 150 and a detector 152 that may be of any suitable type. For example, the emitter 150 may be one or more light emitting diodes adapted to transmit one or more wavelengths of light in the red to infrared range, and the detector 152 may be one or more photodetectors selected to receive light in the range or ranges emitted from the emitter 150. Alternatively, an emitter 150 may also be a laser diode or a vertical cavity surface emitting laser (VCSEL). An emitter 150 and detector 152 may also include optical fiber sensing elements. An emitter 150 may include a broadband or "white light" source, in which case the detector could include any of a variety of elements for selecting specific wavelengths, such as reflective or refractive elements or interferometers. These kinds of emitters and/or detectors would typically be coupled to the rigid or rigidified sensor via fiber optics. Alternatively, a sensor 10 may sense light detected from the tissue is at a different wavelength from the light emitted into the tissue. Such sensors may be adapted to sense fluorescence, phosphorescence, Raman scattering, Rayleigh scattering and multi-photon events or photoacoustic effects. For pulse oximetry applications using either transmission or reflectance type sensors the oxygen saturation of the patient's arterial blood may be determined using two or more wavelengths of light, most commonly red and near infrared wavelengths. Similarly, in other applications, a tissue water fraction (or other body fluid related metric) or a concentration of one or more biochemical components in an aqueous environment may be measured using two or more wavelengths of light, most commonly near infrared wavelengths between about 1,000 nm to about 2,500 nm. It should be understood that, as used herein, the term "light" may refer to one or more of ultrasound, radio, microwave,

millimeter wave, infrared, visible, ultraviolet, gamma ray or X-ray electromagnetic radiation, and may also include any wavelength within the radio, microwave, infrared, visible, ultraviolet, or X-ray spectra.

5 The emitter 150 and the detector 152 may be disposed on a sensor body 154, which may be made of any suitable material, such as plastic, foam, woven material, or paper. Alternatively, the emitter 150 and the detector 152 may be remotely located and optically coupled to the sensor 10 using optical fibers. In the depicted embodiments, the sensor 10 is coupled to a cable 142 that is responsible for transmitting electrical and/or optical signals to and from the emitter 150 and detector 152 of the sensor 10. The cable 10 142 may be permanently coupled to the sensor 10, or it may be removably coupled to the sensor 10 -- the latter alternative being more useful and cost efficient in situations where the sensor 10 is disposable.

The sensor 10 may be a "transmission type" sensor. Transmission type sensors include an emitter 150 and detector 152 that are typically placed on opposing sides of the 15 sensor site. If the sensor site is a fingertip, for example, the sensor 10 is positioned over the patient's fingertip such that the emitter 150 and detector 152 lie on either side of the patient's nail bed. In other words, the sensor 10 is positioned so that the emitter 150 is located on the patient's fingernail and the detector 152 is located 180° opposite the emitter 150 on the patient's finger pad. During operation, the emitter 150 shines one or more 20 wavelengths of light through the patient's fingertip and the light received by the detector 152 is processed to determine various physiological characteristics of the patient. In each of the embodiments discussed herein, it should be understood that the locations of the emitter 150 and the detector 152 may be exchanged. For example, the detector 152 may be located at the top of the finger and the emitter 150 may be located underneath the 25 finger. In either arrangement, the sensor 10 will perform in substantially the same manner.

Reflectance type sensors also operate by emitting light into the tissue and detecting the light that is transmitted and scattered by the tissue. However, reflectance type sensors include an emitter 150 and detector 152 that are typically placed on the same 30 side of the sensor site. For example, a reflectance type sensor may be placed on a patient's fingertip or forehead such that the emitter 150 and detector 152 lie side-by-side.

Reflectance type sensors detect light photons that are scattered back to the detector 152. A sensor 10 may also be a "transflectance" sensor, such as a sensor that may subtend a portion of a baby's heel.

5 While the invention may be susceptible to various modifications and alternative forms, specific embodiments have been shown by way of example in the drawings and have been described in detail herein. However, it should be understood that the invention is not intended to be limited to the particular forms disclosed. Indeed, the present techniques may not only be applied to measurements of blood oxygen saturation, but these techniques may also be utilized for the measurement and/or analysis of other blood
10 and/or tissue constituents using principles of pulse oximetry. For example, using the same, different, or additional wavelengths, the present techniques may be utilized for the measurement and/or analysis of carboxyhemoglobin, methemoglobin, total hemoglobin, fractional hemoglobin, intravascular dyes, and/or water content. Rather, the invention is to cover all modifications, equivalents, and alternatives falling within the spirit and scope of
15 the invention as defined by the following appended claims.

CLAIMS

What is claimed is:

1. A sensor comprising:
a sensor body; and
5 an emitter and a detector disposed on the sensor body, wherein the emitter and the detector are adapted to operate in a transmission mode, and wherein the sensor body is adapted to hold the emitter and detector at a substantially fixed optical distance relative to one another when the sensor is applied to a patient.
10
2. The sensor, as set forth in claim 1, wherein the sensor comprises at least one of a blood constituent sensor or a tissue constituent sensor.
3. The sensor, as set forth in claim 1, wherein the sensor comprises at least one
15 of a pulse oximetry sensor or a sensor for measuring a water fraction.
4. The sensor, as set forth in claim 1, wherein the sensor comprises at least one of a carboxyhemoglobin sensor or a methemoglobin sensor.
- 20 5. The sensor, as set forth in claim 1, wherein the sensor is adapted for intrauterine use.
6. The sensor, as set forth in claim 1, wherein the emitter comprises at least one
25 light emitting diode.
7. The sensor, as set forth in claim 1, wherein the detector comprises at least one photodetector.
8. The sensor, as set forth in claim 1, wherein the sensor body is conformable,
30 and wherein the sensor comprises a stiffening member adapted to reversibly hold the emitter and the detector at the fixed optical distance.

9. The sensor, as set forth in claim 8, wherein the sensor body comprises a cavity adapted to receive the stiffening member.

5 10. The sensor, as set forth in claim 8, wherein the sensor body comprises one or more deformable chambers, wherein the one or more chambers are adapted to receive the stiffening member.

10 11. The sensor, as set forth in claim 8, wherein the stiffening member is embedded within the sensor body.

12. The sensor, as set forth in claim 8, wherein the stiffening member comprises a sleeve.

15 13. The sensor, as set forth in claim 8, wherein the stiffening member comprises a gel, liquid, gas, or foam.

20 14. The sensor, as set forth in claim 8, wherein the stiffening member comprises a metal or a rigid polymeric material.

15. The sensor, as set forth in claim 8, wherein the stiffening member is activated by exposure to a specific condition.

25 16. The sensor, as set forth in claim 1, comprising:
a substantially annular or partially annular sensor body adapted for use on a patient's digit.

30 17. The sensor, as set forth in claim 16, wherein the sensor body is adapted to have an adjustable diameter.

18. The sensor, as set forth in claim 16, wherein the sensor body comprises an adjustment strap.

5 19. The sensor, as set forth in claim 16, wherein the sensor body comprises a hinge.

20. The sensor, as set forth in claim 1, wherein the sensor comprises a clip-style sensor.

10 21. The sensor, as set forth in claim 20, wherein the clip-style sensor comprises a spacer.

22. The sensor, as set forth in claim 21, wherein the spacer comprises a magnet.

15 23. The sensor, as set forth in claim 21, wherein the spacer is adjustable.

24. A sensor comprising:

a conformable sensor body;

an emitter and a detector disposed on the conformable sensor body, wherein the

20 emitter and the detector are adapted to operate in a reflectance mode; and

a stiffening member, wherein the stiffening member is disposed on the conformable

sensor body proximate to the emitter and the detector, and wherein the

stiffening member holds the emitter and the detector at a substantially fixed

optical distance relative to one another when the sensor is applied to a

25 patient.

25. The sensor, as set forth in claim 24, wherein the stiffening member is activated by exposure to a specific condition.

30 26. The sensor, as set forth in claim 24, wherein the sensor comprises at least one of a pulse oximetry sensor or a sensor for measuring a water fraction.

27. The sensor, as set forth in claim 24, wherein the sensor comprises at least one of a carboxyhemoglobin sensor or a methemoglobin sensor.

5 28. The sensor, as set forth in claim 24, wherein the sensor is adapted for intrauterine use.

29. The sensor, as set forth in claim 24, wherein the emitter comprises at least one light emitting diode.

10 30. The sensor, as set forth in claim 24, wherein the detector comprises at least one photodetector.

31. The sensor, as set forth in claim 24, wherein the sensor body comprises a cavity adapted to receive the stiffening member.

15 32. The sensor, as set forth in claim 24, wherein the sensor body comprises one or more deformable chambers, wherein the one or more chambers are adapted to receive the stiffening member.

20 33. The sensor, as set forth in claim 24, wherein the stiffening member is embedded within the sensor body.

34. The sensor, as set forth in claim 24, wherein the stiffening member comprises a gel, liquid, gas, or foam.

25 35. The sensor, as set forth in claim 24, wherein the stiffening member is activated by exposure to a specific condition.

30 36. The sensor, as set forth in claim 24, wherein the stiffening member comprises a metal or a rigid polymeric material.

37. A pulse oximetry system comprising:
a pulse oximetry monitor; and
a pulse oximetry sensor adapted to be operatively coupled to the monitor, the
sensor comprising:

5 a sensor body;
an emitter and a detector disposed on the sensor body, wherein the
sensor is adapted to hold the emitter and detector at a
substantially fixed optical distance relative to one another
when the sensor is applied to a patient.

10 38. The system, as set forth in claim 37, wherein the emitter and the detector are
adapted to operate in transmission mode.

15 39. The system, as set forth in claim 37, wherein the emitter and the detector are
adapted to operate in reflectance mode.

40. The system, as set forth in claim 37, wherein the sensor comprises at least
one of a blood constituent sensor or a tissue constituent sensor.

20 41. The system, as set forth in claim 37, wherein the sensor comprises at least
one of a pulse oximetry sensor or a sensor for measuring a water fraction.

42. The system, as set forth in claim 37, wherein the sensor comprises at least
one of a carboxyhemoglobin sensor or a methemoglobin sensor.

25 43. The system, as set forth in claim 37, wherein the sensor is adapted for
intrauterine use.

30 44. The system, as set forth in claim 37, wherein the emitter comprises at least
one light emitting diode and wherein the detector comprises at least one photodetector.

45. The system, as set forth in claim 37, wherein the sensor body is conformable, and wherein the sensor comprises a stiffening member adapted to reversibly hold the emitter and the detector at a fixed optical distance when applied to a patient.

5 46. The system, as set forth in claim 45, wherein the sensor body comprises a cavity adapted to receive the stiffening member.

10 47. The system, as set forth in claim 45, wherein the sensor body comprises one or more deformable chambers, wherein the chambers are adapted to receive the stiffening member.

48. The system, as set forth in claim 45, wherein the stiffening member is embedded within the conformable sensor body.

15 49. The system, as set forth in claim 45, wherein the stiffening member comprises a sleeve.

50. The system, as set forth in claim 45, wherein the stiffening member comprises a gel, liquid, gas, or foam.

20 51. The system, as set forth in claim 45, wherein the stiffening member comprises a metal or a rigid polymeric material.

25 52. The system, as set forth in claim 37, comprising:
a substantially annular or partially annular sensor body adapted for use on a patient's digit.

53. The system, as set forth in claim 52, wherein the sensor body is adapted to have an adjustable diameter.

30 54. The system, as set forth in claim 52, wherein the sensor body comprises an adjustment strap.

55. The system, as set forth in claim 52, wherein the sensor body comprises a hinge.

56. The system, as set forth in claim 37, wherein the sensor comprises a clip-style sensor.

57. The system, as set forth in claim 56, wherein the clip-style sensor comprises a magnet.

58. The system, as set forth in claim 56, wherein the clip-style sensor comprises a spacer.

59. The system, as set forth in claim 56, wherein the spacer is adjustable.

60. A method comprising:
fixing the optical distance between an emitter and a detector relative to one another, wherein the emitter and the detector are disposed on a sensor body.

61. The method, as set forth in claim 60, wherein fixing the optical distance between the emitter and the detector comprises inserting the stiffening member into a cavity in the sensor body.

62. The method, as set forth in claim 60, wherein fixing the optical distance between the emitter and the detector comprises inserting the stiffening member into one or more deformable chambers in the sensor body.

63. The method, as set forth in claim 60, wherein fixing the optical distance between the emitter and the detector comprises embedding a stiffening member within the sensor body.

64. The method, as set forth in claim 60, wherein fixing the optical distance between the emitter and the detector comprises sliding a sleeve around the sensor.

5 65. The method, as set forth in claim 60, wherein fixing the optical distance between the emitter and the detector comprises inserting a gel, liquid, gas, or foam stiffening member into the sensor body.

10 66. The method, as set forth in claim 60, wherein fixing the optical distance between the emitter and the detector comprises inserting a metal or a rigid polymeric material stiffening member into the sensor body.

15 67. The method, as set forth in claim 60, wherein fixing the optical distance between the emitter and the detector comprises disposing the emitter and the detector on a substantially annular or partially annular sensor body, wherein the sensor body is adapted for use on a patient's digit.

20 68. The method, as set forth in claim 63, wherein fixing the optical distance between the emitter and the detector comprises adjusting the diameter of the sensor body with an adjustment strap.

25 69. The method, as set forth in claim 60, wherein fixing the optical distance between the emitter and the detector comprises engaging a spacer on the sensor body, wherein the sensor body comprises a clip.

30 70. The method, as set forth in claim 60, wherein fixing the optical distance between the emitter and the detector comprises engaging a magnet on the spacer.

71. A method of manufacturing a pulse oximetry sensor, comprising:
providing a sensor body on which an emitter and a detector are disposed, wherein
the sensor body is adapted to hold the emitter and the detector at a
substantially fixed optical distance.

5 72. The method, as set forth in claim 71, comprising:
providing the sensor body, wherein the sensor body is conformable; and
providing a stiffening member, wherein the stiffening member is adapted to
reversibly hold the emitter and the detector at the substantially fixed optical
distance.

73. The method, as set forth in claim 72, comprising:
embedding the stiffening member within the sensor body.

10 74. The method, as set forth in claim 72, comprising:
forming the stiffening member into a sleeve.

75. The method, as set forth in claim 72, comprising:
forming a cavity in the sensor body.

15 76. The method, as set forth in claim 72, comprising:
forming one or more deformable chambers in the sensor body.

20 77. The method, as set forth in claim 71, comprising:
providing an annular or partially annular sensor body on which the emitter and
detector are disposed, wherein the sensor body is adapted to reversibly
hold the emitter and detector at a substantially fixed optical distance.

25 78. The method, as set forth in claim 77, comprising:
providing an adjustment strap.

79. The method, as set forth in claim 77, comprising:
providing a hinge in the sensor body.

30 80. The method, as set forth in claim 71, comprising:
providing a clip-style sensor.

81. The method, as set forth in claim 80, comprising:
providing a spacer.

82. The method, as set forth in claim 80, comprising:
providing a magnet on the spacer.

5

83. The method, as set forth in claim 80, comprising:
providing an adjustable spacer.

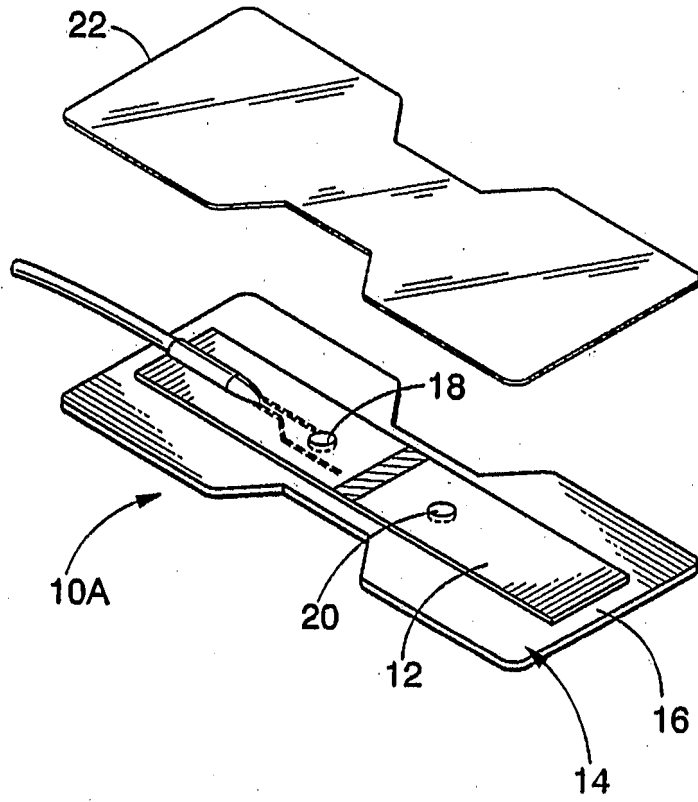

FIG. 1

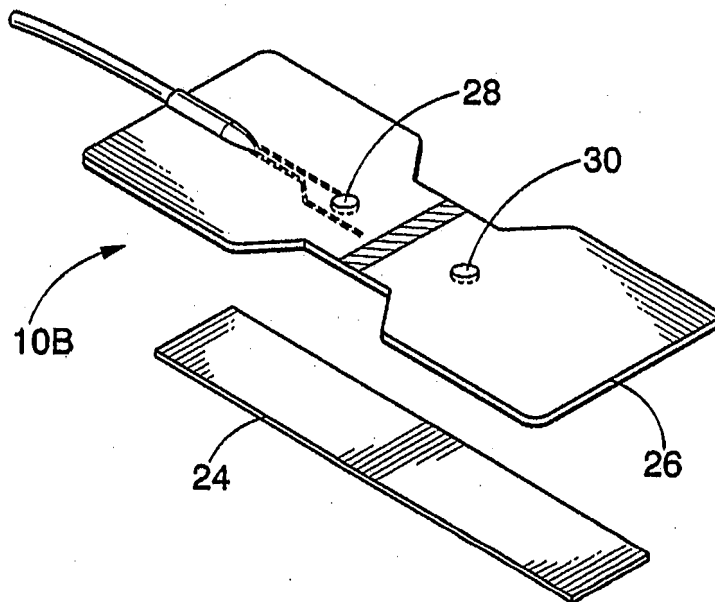
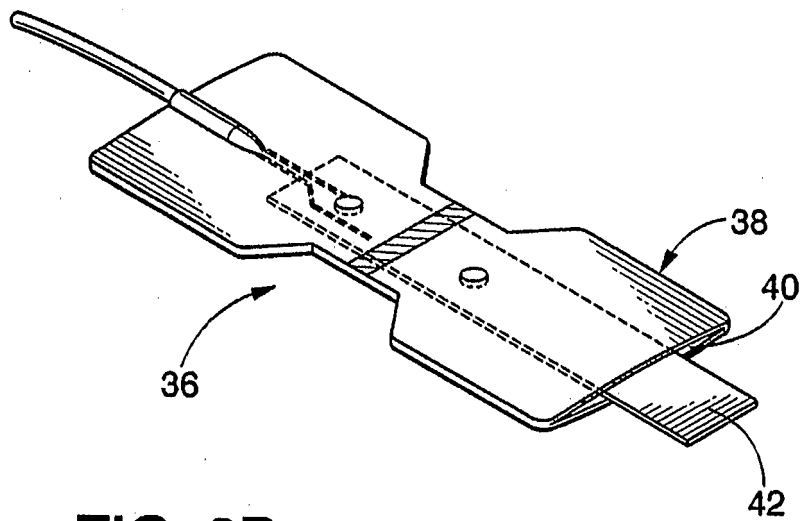
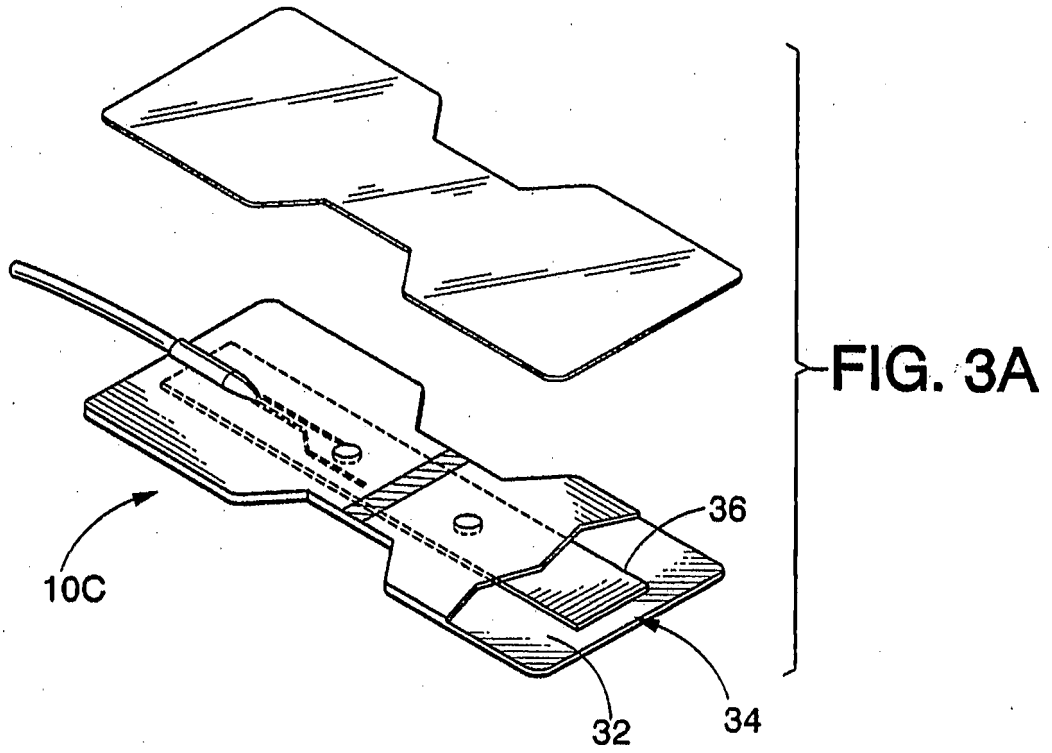
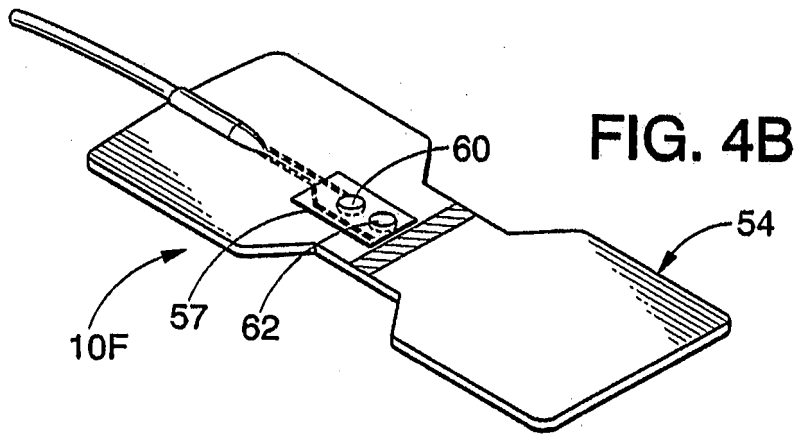
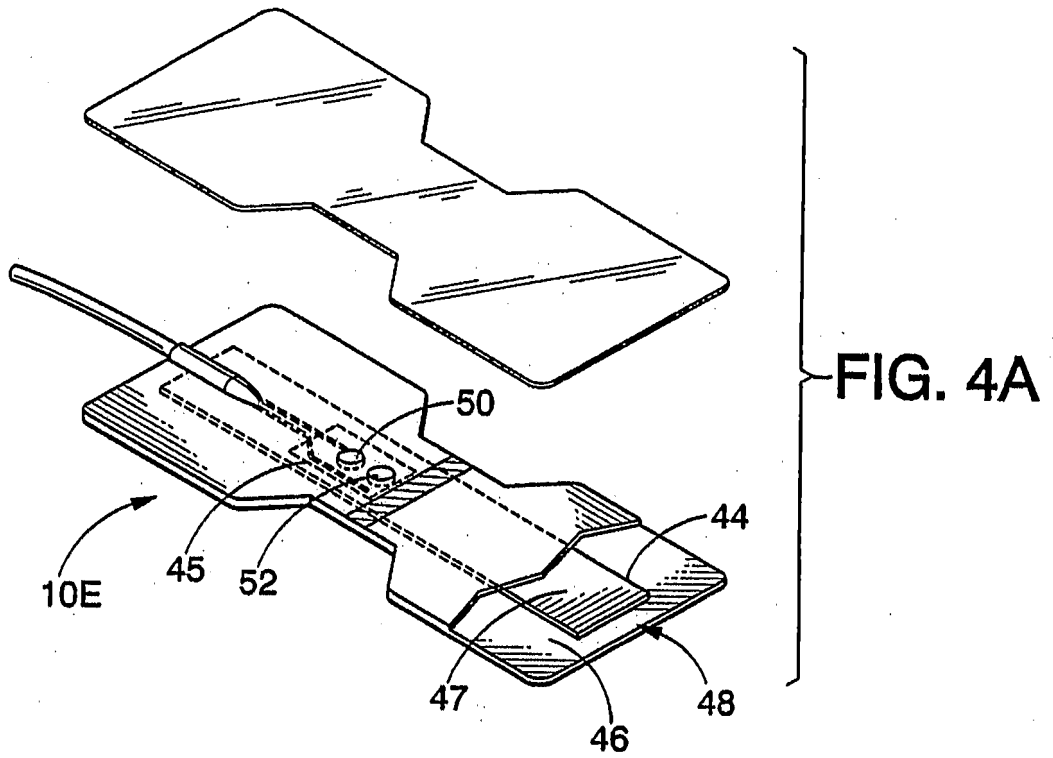

FIG. 2





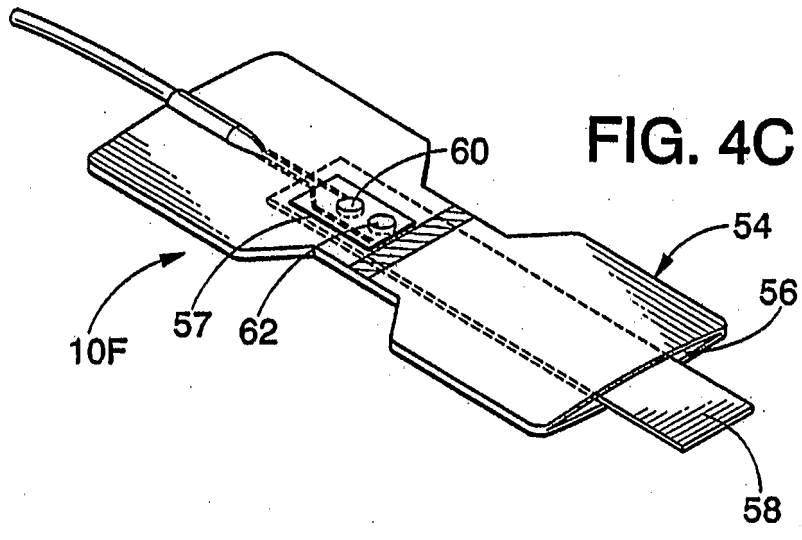

FIG. 4C

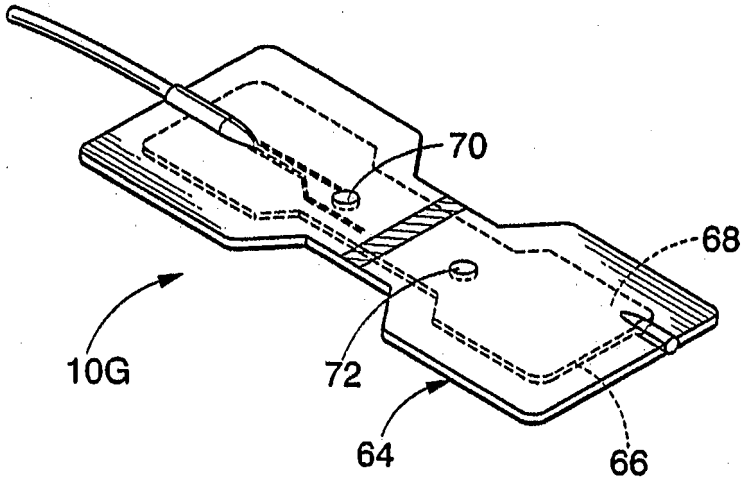

FIG. 5A

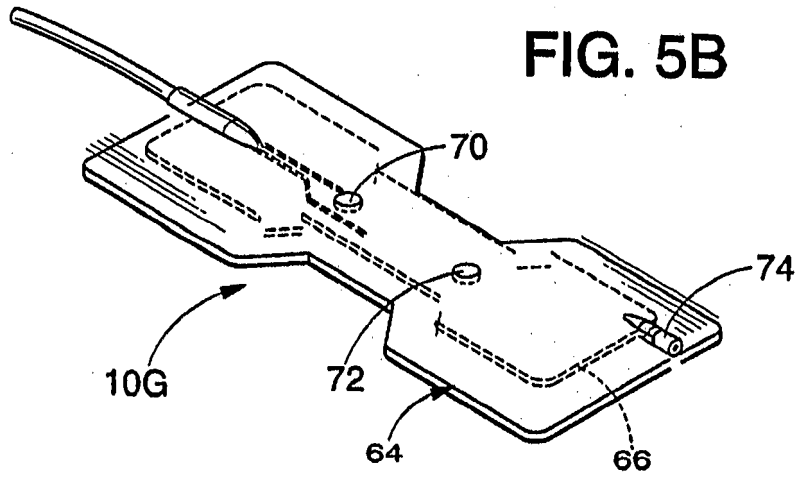
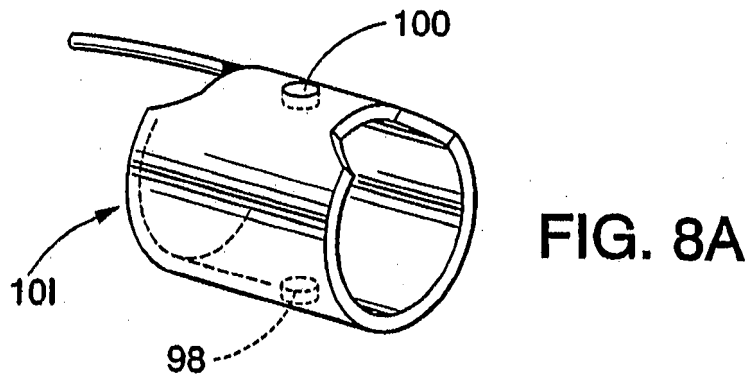
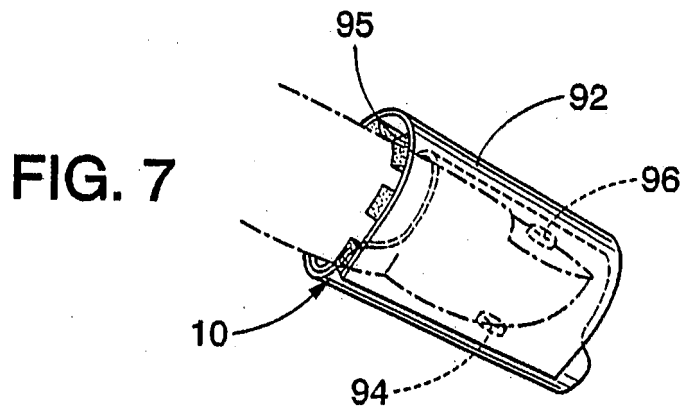
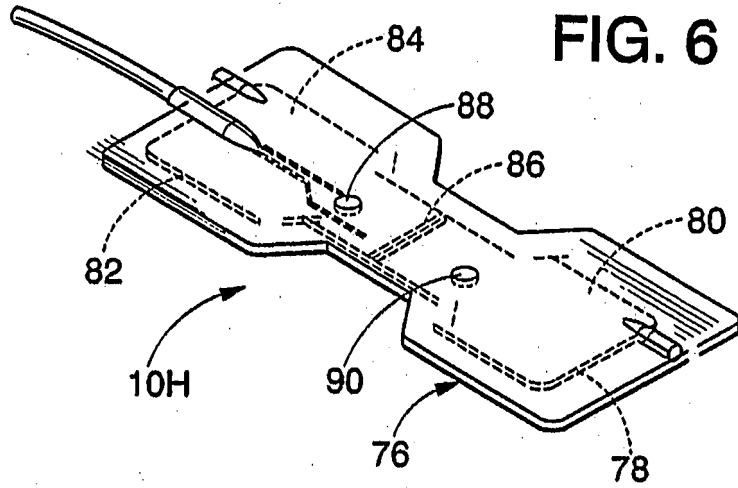

FIG. 5B



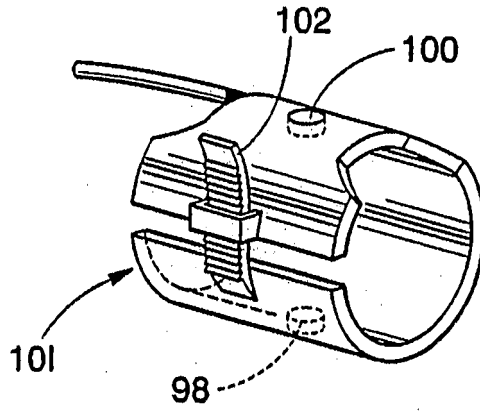

FIG. 8B

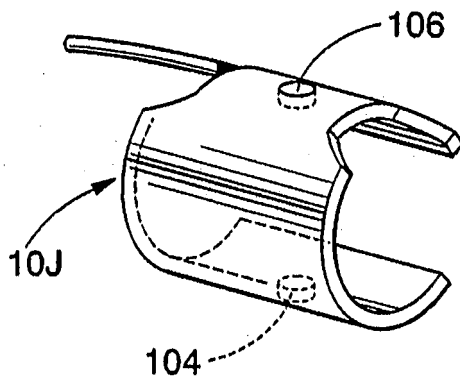

FIG. 9

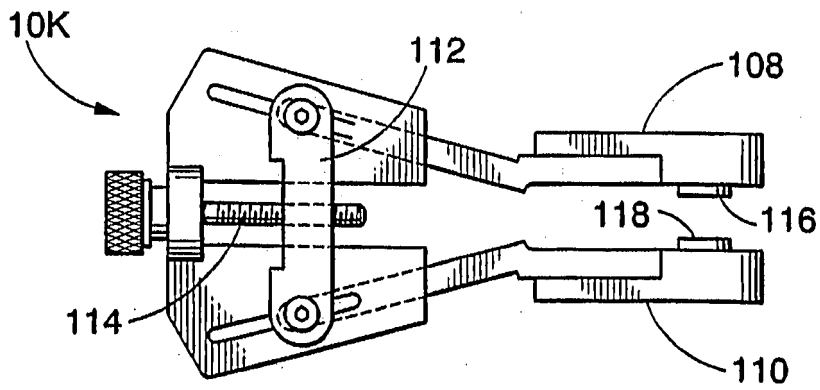

FIG. 10

FIG. 11A

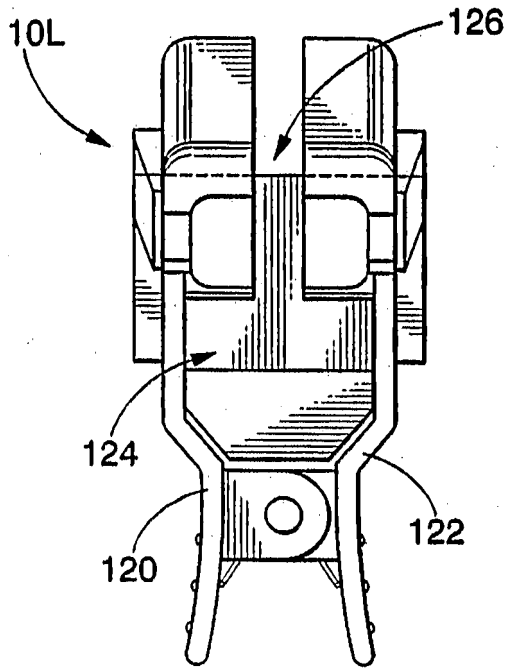

FIG. 11B

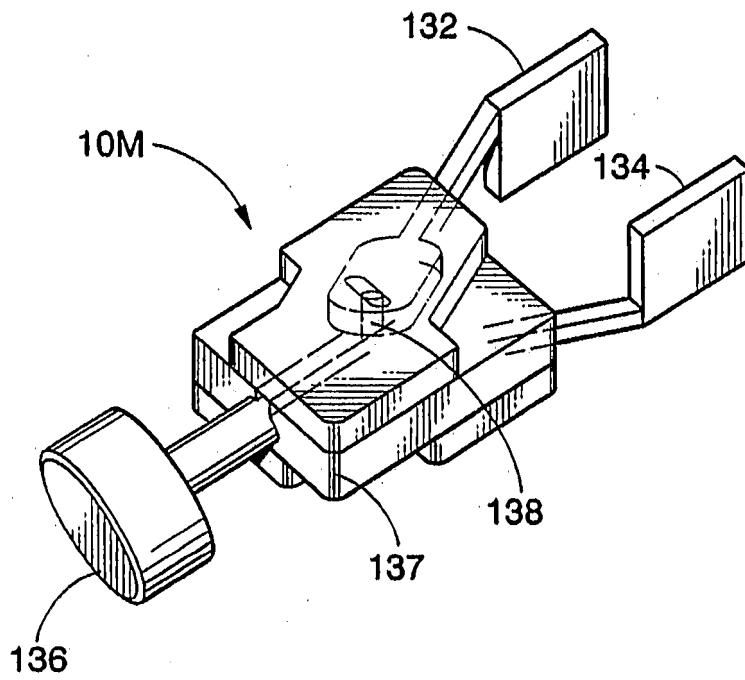
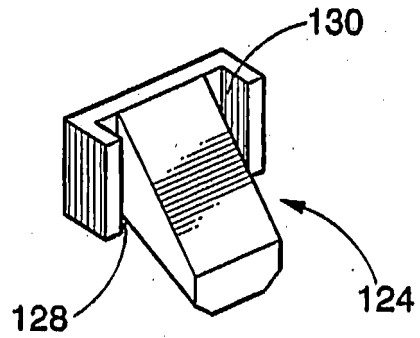
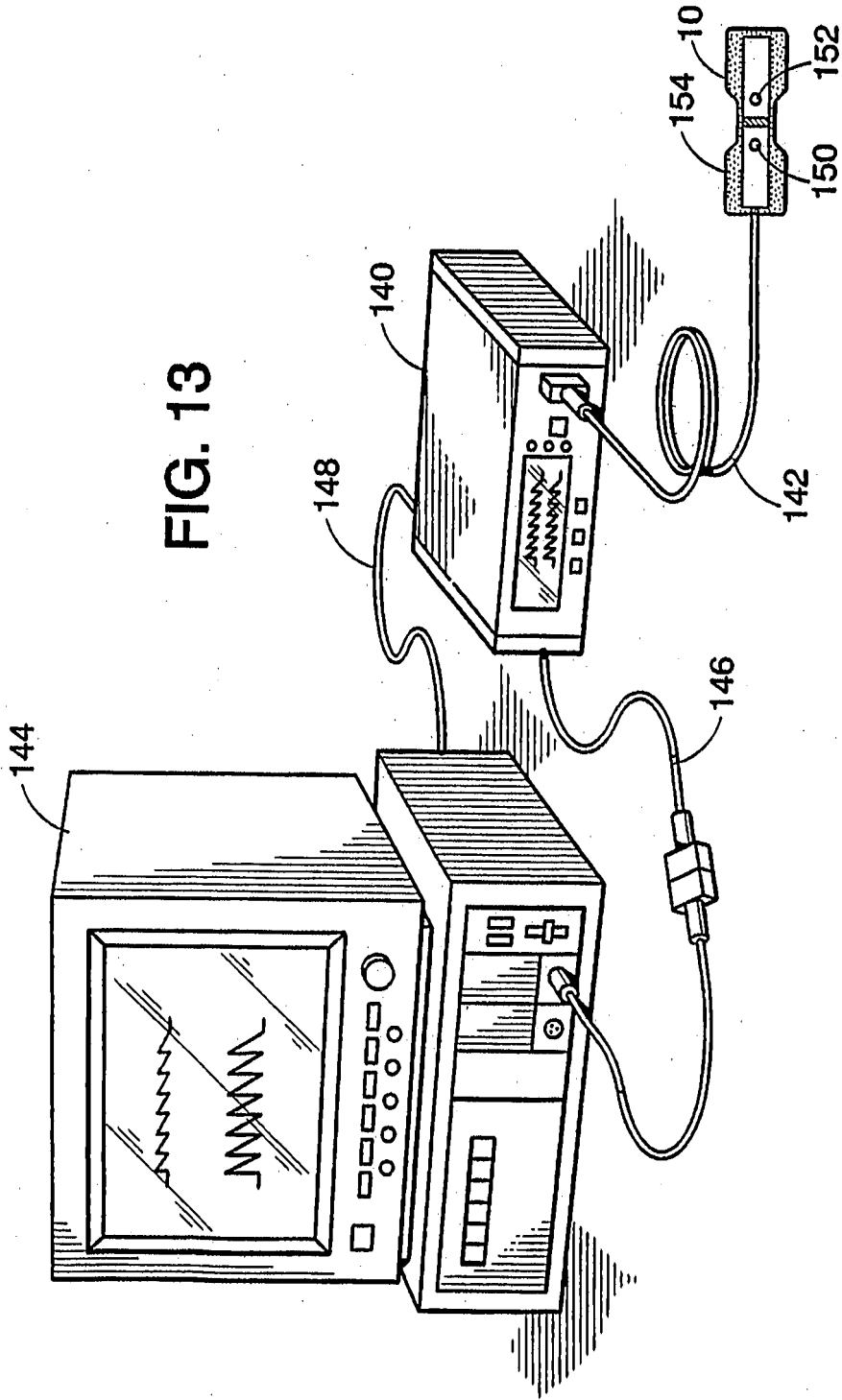

FIG. 12

FIG. 13



INTERNATIONAL SEARCH REPORT

International application No
PCT/US2006/038064

A. CLASSIFICATION OF SUBJECT MATTER
INV. A61B5/00

According to International Patent Classification (IPC) or to both national classification and IPC

B. FIELDS SEARCHED

Minimum documentation searched (classification system followed by classification symbols)
A61B

Documentation searched other than minimum documentation to the extent that such documents are included in the fields searched

Electronic data base consulted during the international search (name of data base and, where practical, search terms used)

EPO-Internal

C. DOCUMENTS CONSIDERED TO BE RELEVANT

Category*	Citation of document, with indication, where appropriate, of the relevant passages	Relevant to claim No.
X	EP 0 898 933 A2 (INSTRUMENTARIUM OY [FI]) 3 March 1999 (1999-03-03) paragraphs [0002], [0006], [0015], [0022], [0025]; figures 3-6 ----- -/--	1-4, 6-8, 14, 20, 24, 26, 27, 29, 30, 36-42, 44, 45, 51, 56, 60, 61, 66, 69, 71, 72, 80

Further documents are listed in the continuation of Box C.

See patent family annex.

* Special categories of cited documents :

- *A* document defining the general state of the art which is not considered to be of particular relevance
- *E* earlier document but published on or after the international filing date
- *L* document which may throw doubts on priority claim(s) or which is cited to establish the publication date of another citation or other special reason (as specified)
- *O* document referring to an oral disclosure, use, exhibition or other means
- *P* document published prior to the international filing date but later than the priority date claimed

- *T* later document published after the international filing date or priority date and not in conflict with the application but cited to understand the principle or theory underlying the invention
- *X* document of particular relevance; the claimed invention cannot be considered novel or cannot be considered to involve an inventive step when the document is taken alone
- *Y* document of particular relevance; the claimed invention cannot be considered to involve an inventive step when the document is combined with one or more other such documents, such combination being obvious to a person skilled in the art.
- *Z* document member of the same patent family

Date of the actual completion of the international search

9 February 2007

Date of mailing of the international search report

21/02/2007

Name and mailing address of the ISA/

European Patent Office, P.B. 5818 Patentlaan 2
NL - 2280 HV Rijswijk
Tel. (+31-70) 340-2040, Tx. 31 651 epo nl,
Fax: (+31-70) 340-3016

Authorized officer

Jonsson, P.O.

INTERNATIONAL SEARCH REPORT

International application No
PCT/US2006/038064

C(Continuation). DOCUMENTS CONSIDERED TO BE RELEVANT		
Category*	Citation of document, with indication, where appropriate, of the relevant passages	Relevant to claim No.
X	<p>WO 03/001180 A2 (PURDUE RESEARCH FOUNDATION [US]; GEDDES LESLIE A [US]; FOSTER KIRK S [] 3 January 2003 (2003-01-03)</p> <p>abstract; figures 1-3 page 5, line 10 - page 6, line 29 -----</p>	<p>1-4, 6-8, 12, 14, 16-19, 24, 26, 27, 29, 30, 36-42, 44, 45, 49, 51-55, 60, 61, 64, 66-68, 71, 72, 74, 77-79</p>
X	<p>US 2002/026109 A1 (DIAB MOHAMED [US] ET AL) 28 February 2002 (2002-02-28)</p> <p>paragraphs [0168] - [0176]; figures 29A, 29B -----</p>	<p>1-4, 6-10, 12, 14, 17, 18, 37, 38, 40-42, 44-47, 49, 51, 53, 54, 60-62, 64, 66, 68, 71, 72, 74, 78</p>
X	<p>WO 98/57577 A1 (RESPIRONICS INC [US]; IYER VIJAY K [US]; JOHNSON ROBERT M [US]; BUSCHM) 23 December 1998 (1998-12-23)</p> <p>page 15, lines 3-10; figure 4 page 18, paragraph V ----- -/--</p>	<p>1-8, 11, 14, 37, 38, 40-45, 48, 51, 60, 61, 63, 66, 71-73</p>

INTERNATIONAL SEARCH REPORT

International application No
PCT/US2006/038064

C(Continuation). DOCUMENTS CONSIDERED TO BE RELEVANT

Category*	Citation of document, with indication, where appropriate, of the relevant passages	Relevant to claim No.
X	US 6 564 088 B1 (SOLLER BABS R [US] ET AL) 13 May 2003 (2003-05-13) abstract; figures 4-6 column 9, line 6 - column 10, line 3 -----	24-27, 29,30, 33,34, 36,37, 39,41, 42,44, 48,50, 51,60, 63,65,66
A	WO 02/074162 A (NELLCOR PURITAN BENNETT INC [US]) 26 September 2002 (2002-09-26) page 7, lines 27-30 page 8, lines 1-22; figure 6 -----	3,26,41

INTERNATIONAL SEARCH REPORT

Information on patent family members

International application No

PCT/US2006/038064

Patent document cited in search report	Publication date	Patent family member(s)	Publication date
EP 0898933	A2	03-03-1999	FI 973454 A US 6285895 B1
			23-02-1999 04-09-2001
WO 03001180	A2	03-01-2003	EP 1404215 A2 JP 2004532710 T US 2003036690 A1
			07-04-2004 28-10-2004 20-02-2003
US 2002026109	A1	28-02-2002	US 6256523 B1 US 2003045785 A1 US 2005043600 A1
			03-07-2001 06-03-2003 24-02-2005
WO 9857577	A1	23-12-1998	AU 756187 B2 AU 7966598 A BR 9810143 A CA 2303803 A1 CN 1260696 A EP 0998214 A1 JP 2002512549 T US 2005283059 A1
			09-01-2003 04-01-1999 27-11-2001 23-12-1998 19-07-2000 10-05-2000 23-04-2002 22-12-2005
US 6564088	B1	13-05-2003	NONE
WO 02074162	A	26-09-2002	CA 2441015 A1 EP 1367938 A1 JP 2004527292 T US 2003220548 A1 US 2002161287 A1
			26-09-2002 10-12-2003 09-09-2004 27-11-2003 31-10-2002

专利名称(译)	医疗传感器		
公开(公告)号	EP1928303A1	公开(公告)日	2008-06-11
申请号	EP2006815800	申请日	2006-09-29
[标]申请(专利权)人(译)	内尔科尔普里坦贝内特公司		
申请(专利权)人(译)	NELLCOR PURITAN BENNETT INCORPORATED		
当前申请(专利权)人(译)	COVIDIEN LP		
[标]发明人	HOARAU CARINE BAKER CLARK R KARST EDWARD		
发明人	HOARAU, CARINE BAKER, CLARK, R. KARST, EDWARD		
IPC分类号	A61B5/00 A61B5/1455		
CPC分类号	A61B5/6886 A61B5/14552 A61B5/6826 A61B5/6838 A61B5/6844 Y10T29/49826		
代理机构(译)	GRUBERT , ANDREAS		
优先权	11/241375 2005-09-29 US		
其他公开文献	EP1928303B1		
外部链接	Espacenet		

摘要(译)

用于脉搏血氧测定法或利用分光光度法的其他应用的传感器可以适于通过固定发射器和检测器之间的光学距离来减少运动伪影。柔性传感器设置有加强构件，以在应用于患者时将传感器的发射器和检测器保持在相对固定的位置。此外，环形或部分环形传感器适于在应用于患者时将传感器的发射器和检测器保持在相对固定的位置。夹式传感器设有间隔器，用于控制发射器和检测器之间的距离。