

(19) World Intellectual Property Organization  
International Bureau



(43) International Publication Date  
12 September 2002 (12.09.2002)

PCT

(10) International Publication Number  
**WO 02/069795 A1**

(51) International Patent Classification<sup>7</sup>: **A61B 5/00**

(21) International Application Number: PCT/US02/03712

(22) International Filing Date: 7 February 2002 (07.02.2002)

(25) Filing Language: English

(26) Publication Language: English

(30) Priority Data:  
09/782,502 13 February 2001 (13.02.2001) US

(71) Applicant: **SCIMED LIFE SYSTEMS, INC.** [US/US];  
One SciMed Place, Maple Grove, MN 55311 (US).

(72) Inventors: **KOKATE, Jaydeep, Y.**; 7000 Magda Drive,  
#107, Maple Grove, MN 55369 (US). **DOBRAVA, Eric,  
M.**; 5419 Louisiana Avenue, Crystal, MN 55428 (US).  
**BERRADA, Marwane, S.**; 401 9th Street S.E., #304, Min-  
neapolis, MN 55414 (US). **KIMMEL, Scott**; 111 East  
Kellogg Boulevard #2711, Saint Paul, MN 55101 (US).  
**PRSTIC, Suzana**; 1018 27th Avenue S.E., Apartment F,

Minneapolis, MN 55414 (US). **HOEY, Michael, F.**; 5377  
Pond Drive, Shoreview, MN 55126 (US). **BAR-COHEN,  
Avram**; 1440 Utah Avenue South, St. Louis Park, MN  
55426 (US). **IAZZO, Paul, A.**; 3974 Birch Knoll Drive,  
White Bear Lake, MN 55110 (US).

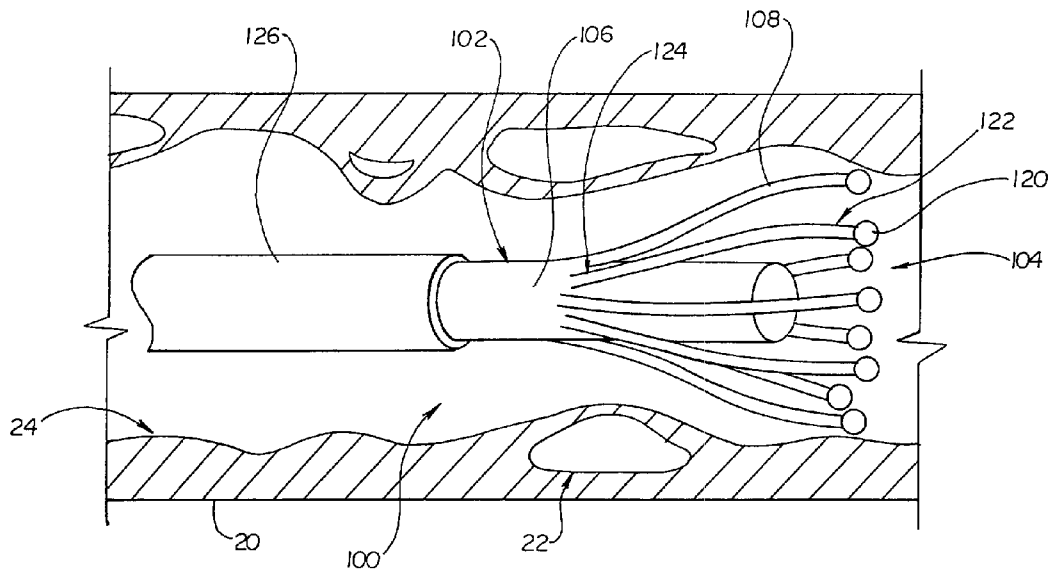
(74) Agents: **SEAGER, Glenn, M.** et al.; Crompton, Seager  
& Tufto LLC, Suite 895, 331 Second Avenue South, Min-  
neapolis, MN 55401 (US).

(81) Designated States (*national*): AE, AG, AL, AM, AT, AU,  
AZ, BA, BB, BG, BR, BY, BZ, CA, CH, CN, CO, CR, CU,  
CZ, DE, DK, DM, DZ, EC, EE, ES, FI, GB, GD, GE, GH,  
GM, HR, HU, ID, IL, IN, IS, JP, KE, KG, KP, KR, KZ, LC,  
LK, LR, LS, LT, LU, LV, MA, MD, MG, MK, MN, MW,  
MX, MZ, NO, NZ, OM, PH, PL, PT, RO, RU, SD, SE, SG,  
SI, SK, SL, TJ, TM, TN, TR, TT, TZ, UA, UG, UZ, VN,  
YU, ZA, ZM, ZW.

(84) Designated States (*regional*): ARIPO patent (GH, GM,  
KE, LS, MW, MZ, SD, SL, SZ, TZ, UG, ZM, ZW),  
Eurasian patent (AM, AZ, BY, KG, KZ, MD, RU, TJ, TM),  
European patent (AT, BE, CH, CY, DE, DK, ES, FI, FR,

[Continued on next page]

(54) Title: INTRAVASCULAR TEMPERATURE SENSOR



(57) Abstract: Devices and methods for detecting vulnerable plaque within a blood vessel are disclosed. A catheter in accordance with the present invention includes an elongate shaft having a proximal end, a distal end, and an outer surface. At least one temperature sensor is disposed proximate to the distal end of the elongate shaft. In one preferred embodiment, the at least one temperature sensor is adapted to contact inner surface of the blood vessel. In another preferred embodiment, at least one temperature sensor is disposed within a channel defined by a body member that is disposed about the elongate shaft.



WO 02/069795 A1



GB, GR, IE, IT, LU, MC, NL, PT, SE, TR), OAPI patent (BF, BJ, CF, CG, CI, CM, GA, GN, GQ, GW, ML, MR, NE, SN, TD, TG).

*For two-letter codes and other abbreviations, refer to the "Guidance Notes on Codes and Abbreviations" appearing at the beginning of each regular issue of the PCT Gazette.*

**Published:**

— *with international search report*

## INTRAVASCULAR TEMPERATURE SENSOR

### Field of the Invention

The present invention relates generally to medical devices for detecting  
5 cardiac disease. More particularly, the present invention relates to medical devices  
for detecting vulnerable plaque within a blood vessel.

### Background of the Invention

Therapy modalities for heart disease have traditionally focused on treating  
blood vessels which have become occluded (blocked) or stenotic (narrowed) by  
10 calcified plaque deposits. Blood vessels which have become occluded or stenotic in  
this manner may interrupt the blood flow which supplies oxygen to the heart muscle.  
Occluded or stenotic blood vessels may be treated with a number of medical  
procedures including angioplasty and atherectomy. Angioplasty techniques such as  
percutaneous transluminal angioplasty (PTA) and percutaneous transluminal coronary  
15 angioplasty (PTCA) are relatively non-invasive methods of treating restrictions in  
blood vessels. In these procedures, a balloon catheter is advanced over a guidewire  
until the balloon is positioned proximate to a restriction in a diseased vessel. The  
balloon is then inflated and the restriction in the vessel is stretched. During an  
atherectomy procedure, the stenotic lesion is mechanically cut or abraded away from  
20 the blood vessel wall using an atherectomy catheter.

Calcified plaque deposit typically comprise hard materials. But, plaque may  
also comprise soft materials or combinations of soft and hard materials. Soft plaque  
typically comprises deposits of cholesterol and other fats which build up within the  
blood vessels as a patient ages. The build up of plaque in the blood vessels is  
25 sometimes referred to as atherosclerosis, or hardening of the arteries.

Atherosclerosis often begins as a small injury to an artery wall. This injury triggers a cascade of injury and response, inflammation, and healing, which may ultimately lead to the narrowing of the artery. As the atherosclerotic plaque worsens, inflammatory cells, especially macrophages, collect, at the site to isolate, the debris of the damaged tissue. The result is a core of lipid, macrophages or foam cells and necrotic tissue, covered by a thin fibrous cap of scar tissue. If the fibrous cap becomes weakened or is subjected to excessive mechanical stress, it may rupture, exposing the thrombogenic damaged endothelium and metabolic byproducts to the blood stream. If the resulting blood clot is severe enough, it may occlude the artery. If this obstruction persists in a coronary artery, a myocardial infarction or angina may result.

Plaque deposits which are at risk of rupturing are sometimes referred to as vulnerable plaque. Vulnerable plaque typically comprises a core of soft materials covered with a fibrous cap. Many of vulnerable plaque deposits do not limit the flow of blood through the blood vessels. It has recently been appreciated that vulnerable plaques which do not limit flow may be particularly dangerous because they can rupture suddenly causing heart attack and death. This may occur, for example, when the vulnerable plaque ruptures and a blood clot is formed inside the blood vessel lumen causing a blockage.

Recently, the pivotal role of inflammation in the progression of atherosclerosis has been recognized. A systemic increase in temperature is often associated with infection (e.g., a fever). Likewise, a local infection or localized damage to tissue may result in a localized increase in temperature. An increase in temperature is thought to be caused by the response of the immune system to infection, known as inflammation

and an increase in metabolic activity involved in the healing process. It has been observed that the inflamed necrotic core of a vulnerable plaque maintains itself at a temperature which may be one or more degrees Celsius higher than the surrounding tissue. For example, an inflamed plaque in a human heart, where the normal  
5 temperature is about 37°C may be at a temperature as high as 40°C.

#### Summary of the Invention

The present invention relates generally to medical devices for detecting cardiac disease. More particularly, the present invention relates to medical devices for detecting vulnerable plaque within a blood vessel. A catheter in accordance with  
10 one embodiment of the present invention includes an elongate shaft and a plurality of arms fixed to the elongate shaft.

The arms preferably have an extended position and a retracted position. A sensor is fixed to each arm proximate a first end thereof. In a preferred embodiment, each sensor contacts the inner surface of a blood vessel when the arms are in the  
15 extended position. In a preferred embodiment, a sheath is disposed about the elongate shaft elongate shaft. The arms may be urged into the retracted position by advancing the sheath distally along the elongate shaft.

The signal from each sensor may be displayed and/or recorded using a suitable instrument. Variations in these signals may be noted as the catheter is moved  
20 proximally and/or distally through the blood vessel thereof thermally mapping the transversed region. The variations in the sensor signal may be correlated with the axial position of the catheter. This information may be used to identify the position of any vulnerable plaque deposits in the blood vessel.

In a preferred embodiment, the arms of the catheter expand radially away from the elongate shaft. The angular orientation of plaque deposits within the blood vessel may be identified by observing variations between the signals from the different sensors. For example, sensors which are proximate to vulnerable plaque deposits may  
5 read higher temperatures than sensors which are not proximate to vulnerable plaque deposits.

A catheter in accordance with an additional embodiment of the present invention includes one arm comprising a spring which is biased to assume an extended position. A sensor is fixed to the arm proximate a first end thereof. This  
10 catheter may also be used for mapping the locations of vulnerable plaque deposits within a blood vessel.

In a preferred embodiment, the sensor contacts the inner surface of the blood vessel when the arm is in the extended position. In this preferred embodiment, the temperature measured by the sensor may rise when the sensor is proximate to a  
15 vulnerable plaque deposit. Variations in the temperature measured by the sensor may be noted as the catheter is moved proximally and/or distally through the blood vessel, and these variations may be correlated to the axial position of vulnerable plaque deposits. Variations in the signal from the sensor may also be noted as the catheter is rotated about its longitudinal axis. These variations may be correlated to the angular  
20 location of vulnerable plaque deposits within the blood vessel.

Yet another exemplary embodiment of a catheter in accordance with the present invention includes a body member disposed about an elongate shaft of the catheter. The body member defines a plurality of flow channels and a temperature sensor is disposed within each channel. This catheter may also be used along with

methods in accordance with the present invention for mapping the locations of vulnerable plaque deposits within the blood vessel.

The body member of the catheter is preferably sized so that an outer surface of the body member is disposed proximate the inner surface of the blood vessel. When  
5 this is the case, blood flowing proximate the inner surface of the blood vessel will flow into the channels. Sensors may be used to measure the temperature of the blood flowing through the channels. Blood which flows over a vulnerable plaque deposit will be warmed by the vulnerable plaque deposit. The increased temperature of this blood may be observed and/or recorded using the sensors disposed within the  
10 channels.

As the catheter is moved proximally and/or distally through the blood vessel, the distal end of the body member will be proximate different portions of the inner surface of the blood vessel. Variations in the signals from the sensors may be noted as the catheter is moved proximally and/or distally through the blood vessel, and these  
15 variations may be correlated to the axial position of the catheter. This information may be used to identify an axial component of the position of any vulnerable plaque deposits in the blood vessel.

The flow channels and the sensors are preferably disposed radially about the elongate shaft. An angular component of the position of plaque deposits within the  
20 blood vessel may be identified by observing variations between the signals from the different sensors. For example, sensors which are proximate vulnerable plaque deposits may read higher temperatures than sensors which are not proximate vulnerable plaque deposits.

Brief Description of the Drawings

Figure 1 is a perspective view of a catheter in accordance with an exemplary embodiment of the present invention;

Figure 2 is a lateral cross-sectional view of a blood vessel, and the catheter of Figure 1 is shown disposed within a lumen defined by the blood vessel;

Figure 3 is a plan view of a catheter in accordance with an additional exemplary embodiment of the present invention;

Figure 4 is a perspective view of a catheter in accordance with yet another exemplary embodiment of the present invention;

Figure 5 is a perspective view of a catheter in accordance with an exemplary embodiment of the present invention;

Figure 6 is a partial cross sectional view of catheter of Figure 5;

Figure 7 is a perspective view of a catheter in accordance with still another exemplary embodiment of the present invention;

Figure 8 is a perspective view of a catheter in accordance with still another exemplary embodiment of the present invention;

Figure 9 is a perspective view of a catheter in accordance with still another exemplary embodiment of the present invention;

Figure 10 is a cross sectional perspective view of a catheter in accordance with still another exemplary embodiment of the present invention;

Figure 11 is a cross sectional plan view of the catheter of Figure 10; and

Figure 12 is a cross sectional plan view of a catheter in accordance with yet another exemplary embodiment of the present invention.

Detailed Description of the Invention

The following detailed description should be read with reference to the drawings, in which like elements in different drawings are numbered in like fashion. The drawings which are not necessarily to scale, depict selected embodiments and are not intended to limit the scope of the invention. In some cases, the drawings may be highly diagrammatic in nature. Examples of constructions, materials, dimensions, and manufacturing processes are provided for various elements. Those skilled in the art will recognize that many of the examples provided have suitable alternatives which may be utilized.

Figure 1 is a perspective view of a catheter 100 in accordance with an exemplary embodiment of the present invention. Catheter 100 may be used for mapping the locations of vulnerable plaque deposits 22 within a blood vessel 20. Catheter 100 comprises an elongate shaft 102 having a distal end 104, a proximal end (not shown in Figure 1) and an outer surface 106. Catheter 100 also includes a plurality of arms 108. In the embodiment of Figure 1, a sensor 120 is fixed to each arm 108 proximate a first end 122 thereof. A second end 124 of each arm 108 is fixed to elongate shaft 102.

Arms 108 preferably have an extended position and a retracted position. In the embodiment of Figure 1, arms 108 are shown in the extended position. A sheath 126 is disposed about elongate shaft 102. Arms 108 may be urged into the retracted position by advancing sheath 126 distally along elongate shaft 102. In a preferred embodiment, each sensor 120 contacts inner surface 24 of blood vessel 20 when arms 108 are in the extended position.

Each sensor 120 may comprise a temperature sensor, an ultrasonic sensor, and/or an electromagnetic radiation sensor. In a preferred embodiment, each sensor 120 comprises a temperature sensor. Examples of temperature sensors which may be suitable in some applications include resistance temperature devices (RTD's),  
5 thermistors, thermocouples, MEMS (microelectrical mechanical systems).

Blood vessel 20 includes a plurality of vulnerable plaque deposits 22. Each vulnerable plaque deposit includes a core portion 26 comprising a relatively soft material and a cap 28 overlaying the core. As catheter 100 is moved proximally and/or distally through blood vessel 20, sensors 120 preferably contact different  
10 portions of inner surface 24 of blood vessel 20.

The signal from each sensor 120 may be displayed and/or recorded using a suitable instrument. Variations in these signals may be noted as catheter 100 is moved proximally and/or distally through blood vessel 20. The variations in the sensor signal may be correlated with the axial position of catheter 100. This  
15 information may be used to identify the position of any vulnerable plaque deposits in blood vessel 20.

Figure 2 is a lateral cross-sectional view of a blood vessel 20. Catheter 100 of Figure 1 is shown disposed within a lumen 30 of blood vessel 20. Catheter 100 may be used for mapping the location of vulnerable plaque deposits 22 within a blood  
20 vessel 20 as described above. In Figure 2, it may be appreciated that arms 108 of catheter 100 expand radially away from elongate shaft 102. A sensor 120 is fixed to each arm 108 proximate a first end 122 thereof. A second end 124 of each arm 108 is fixed to elongate shaft 102. The angular orientation of plaque deposits 22 within blood vessel 20 may be identified by observing variations between the signals from

the different sensors 120. For example, sensors 120 which are proximate vulnerable plaque deposits 22 may read higher temperatures than sensors 120 which are not proximate vulnerable plaque deposits.

Figure 3 is a plan view of a catheter 200 in accordance with an additional  
5 exemplary embodiment of the present invention. Catheter 200 comprises an elongate shaft 202 having a distal end 204, a proximal end (not shown in Figure 3) and an outer surface 206. Catheter 200 also includes a plurality of arms 208. In the embodiment of Figure 3, a sensor 220 is fixed to each arm 208 proximate a first end 222 thereof. A middle portion 226 of each arm 208 is fixed to elongate shaft 202 of catheter 200, and  
10 a free portion 228 of each arm 208 extends away from elongate shaft 202. In a preferred embodiment, free portions 228 of arms 208 act to stabilize the flow of blood when catheter 200 is disposed within a blood vessel. In the embodiment of Figure 3, arms 208 are shown in the extended position. Arms 208 preferably have an extended position and a retracted position.

15 Figure 4 is a perspective view of a catheter 300 in accordance with yet another exemplary embodiment of the present invention. Catheter 300 may be used for mapping the locations of vulnerable plaque deposits within a blood vessel. Catheter 300 comprises an elongate shaft 302 having a distal end 304, a proximal end (not shown in Figure 4) and an outer surface 306.

20 A sheath 326 is slidably disposed about a portion of elongate shaft 302. The first ends 322 of a plurality of arms 308 are fixed to sheath 326. The second end 324 of each arm 308 is fixed to a body member 330 of catheter 300. In the embodiment of Figure 4, body member 330 is disposed about elongate shaft 302 proximate distal end 304. A sensor 320 is fixed to each arm 308 between first end 322 and second end

324. In the embodiment of Figure 4, arms 308 are shown in the extended position. In a preferred embodiment, arms 308 are biased to assume the extended position. Arms 308 may be urged into a retracted position by moving sheath 326 proximally relative to elongate shaft 302. Arms 308 may also be urged into the extended position by  
5 moving sheath 326 distally relative to elongate shaft 302. In a preferred embodiment, each sensor 320 contacts the inner surface of a blood vessel when arms 308 are in the extended position.

Each sensor 320 may comprise various sensor types without deviating from the spirit and scope of the present invention. Examples of sensors which may be  
10 suitable in some applications include pressure sensors, ultrasonic sensors, electromagnetic radiation sensors, and temperature sensors. In a preferred embodiment, each sensor 320 comprises a temperature sensor. Temperature sensors which may be suitable in some applications, include resistance temperature devices (RTD's), thermistors, thermocouples, and MEMS.

15 Figure 5 is a perspective view of a catheter 400 in accordance with an exemplary embodiment of the present invention. Catheter 400 also includes an arm 408 comprising spring 432 which is biased to assume the extended position shown in Figure 5. A sensor 420 is fixed to arm 408 proximate a first end 422 thereof. A second end 424 of arm 408 is fixed to an elongate shaft 402. Elongate shaft 402  
20 includes a distal end 404, a proximal end (not shown in Figure 5) and an outer surface 406.

In Figure 5, catheter 400 is shown disposed within a blood vessel 20 having vulnerable plaque deposits 22. Catheter 400 may be used for mapping the locations of the vulnerable plaque deposits 22 within blood vessel 20. In a preferred

embodiment, sensor 420 contacts inner surface 24 of blood vessel 20 when arm 408 is in the extended position shown in Figure 5. In this preferred embodiment, the temperature measured by sensor 420 may rise when sensor 420 is proximate a vulnerable plaque deposit 22.

5           Each vulnerable plaque deposit shown in Figure 5 includes a core portion 26 comprising a relatively soft material and a cap 28 overlaying the core. As catheter 400 is moved proximally and/or distally through blood vessel 20, sensors 420 preferably contact different portions of inner surface 24 of blood vessel 20.

          The signal from sensor 420 may be displayed and/or recorded using a suitable  
10 instrument. Variations in the signal may be noted as catheter 400 is moved proximally and/or distally through blood vessel 20, and these variations may be correlated with the axial position of catheter 400. Variations in the signal from sensor 420 may also be noted as catheter 400 is rotated about its longitudinal axis. These variations may be correlated with the angular orientation of catheter 400. The  
15 information collected from sensor 420 may be used to identify the position of any vulnerable plaque deposits in blood vessel 20.

          Figure 6 is a partial cross sectional view of catheter 400 of Figure 5. In Figure 6, it may be appreciated that catheter 400 includes a sheath 426 which is disposed about elongate shaft 402. In the embodiment of Figure 6, sheath 426 has been  
20 advanced distally along elongate shaft 402 so that arm 408 of catheter 400 is disposed in a retracted position. In Figure 6 it may be appreciated that catheter 400 includes a cable 434 disposed between sheath 426 and elongate shaft 402. A distal end of cable 434 is preferably coupled to sensor 420 and a proximal end of cable 434 is preferably coupled to an instrument which is adapted to display and/or record a signal from

sensor 420. It is to be appreciated, that cable 434 may include any number of conductors. In some applications, the number of conductors may be selected to match sensor 420. For example, sensor 420 may comprise a thermocouple having two contacts which are coupled to two conductors of cable 434.

5           Figure 7 is a perspective view of a catheter 500 in accordance with still another exemplary embodiment of the present invention. Catheter 500 comprises an elongate shaft 502 having a distal end 504, a proximal end (not shown in Figure 7) and an outer surface 506. A body member 530 of catheter 500 is disposed about elongate shaft 502. Body member 530 defines a plurality of flow channels 536.

10           In the embodiment of Figure 7, a sensor 520 is disposed within each flow channel 536. Catheter 500 also includes a reference sensor 521 disposed proximate distal end 504 of elongate shaft 502. Sensors 520 and 521 preferably comprises a temperature sensors. Examples of temperature sensors which may be suitable in some applications include resistance temperature devices (RTD's), thermistors, and  
15 thermocouples.

Catheter 500 may be used for mapping the locations of vulnerable plaque deposits within a blood vessel. Body member 530 is preferably sized so that an outer surface 505 of body member 530 is disposed proximate the inner surface of a blood vessel. When this is the case, blood flowing proximate the inner surface of the blood  
20 vessel will flow into the channels. Sensors 520 may be used to measure the temperature of the blood flowing through the channels. Blood which flows over a vulnerable plaque deposit will be warmed by the vulnerable plaque deposit. The increased temperature of this blood may be observed and/or recorded using sensors 520.

As catheter 500 is moved proximally and/or distally through a blood vessel, the distal end of body member 530 will be proximate different portions of the inner surface of the blood vessel. Variations in the signals from the sensors may be noted as catheter 500 is moved proximally and/or distally through the blood vessel, and  
5 these variations may be correlated axial position of catheter 500. This information may be used to identify an axial component of the position of any vulnerable plaque deposits in the blood vessel.

In Figure 7, it may be appreciated that flow channels 536 and sensors 520 are disposed radially about elongate shaft 502. An angular component of the position of  
10 plaque deposits within blood vessel may be identified by observing variations between the signals from the different sensors 520. For example, sensors 520 which are proximate vulnerable plaque deposits may read higher temperatures than sensors 520 which are not proximate vulnerable plaque deposits.

Figure 8 is a perspective view of a catheter 600 in accordance with still  
15 another exemplary embodiment of the present invention. Catheter 600 may be used for mapping the locations of vulnerable plaque deposits within a blood vessel. Catheter 600 comprises an elongate shaft 602 having a distal end 604, a proximal end (not shown in Figure 8) and an outer surface 606. A sensor 620 is disposed so that it overlays outer surface 606 of elongate shaft 602. In the embodiment of Figure 8,  
20 sensor 620 comprises a flexible substrate 640 and a conductive path 638. Conductive path 638 is coupled to a first conductor 642 and a second conductor 644. In a preferred embodiment, the electrical resistance of conductive path 638 varies with temperature. Also in a preferred embodiment, first conductor 642 and a second conductor 644 are insulated. First conductor 642 and a second conductor 644 may be

insulated, for example, by a layer of shrink tubing overlaying elongate shaft 602. In the embodiment of Figure 8, sensor 620 has a generally cylindrical outer surface 605. In a preferred embodiment, the shape of outer surface 605 is selected so that sensor 620 contacts the inner surface of a blood vessel across a substantial area.

5           Figure 9 is a perspective view of a catheter 700 in accordance with still another exemplary embodiment of the present invention. Catheter 700 may be used for mapping the locations of vulnerable plaque deposits within a blood vessel. Catheter 700 comprises an elongate shaft 702 having a distal end 704, a proximal end (not shown in Figure 9) and an outer surface 706. Catheter 700 also includes a sensor  
10       720 disposed proximate distal end 704 of elongate shaft 702. In the embodiment of Figure 9, sensor 720 comprises a body 746 having a generally cylindrical shape. In a preferred embodiment, the shape of body 746 is selected so that sensor 720 contacts the inner surface of a blood vessel across a substantial area. A first conductor 742 and a second conductor 744 are coupled to sensor 720. In a preferred embodiment, a  
15       temperature recording and displaying instrument may interrogate sensor 720 via first conductor 742 and second conductor 744.

          Figure 10 is a cross sectional perspective view of a catheter 800 in accordance with still another exemplary embodiment of the present invention. Catheter 800 comprises an elongate shaft 802 having an outer surface 806. A balloon 850 of  
20       catheter 800 is disposed about elongate shaft 802.

          Catheter 800 also includes an array 852 comprising plurality of cowls 854 circumferentially disposed about balloon 850. Cowls 854 are preferably fixed to balloon 850. Each cowl 854 defines an inlet port 856, an outlet port 858, and a flow channel 836 extending therebetween.

A sensor 820 (not shown in Figure 10) is preferably disposed within each flow channel 836. Each sensor 820 preferably comprises a temperature sensor. Examples of temperature sensors which may be suitable in some applications include resistance temperature devices (RTD's), thermistors, and thermocouples.

5 Balloon 850 preferably has an inflated state and a deflated state. In the embodiment of Figure 10, balloon 850 is disposed outside of a blood vessel, and is shown in an inflated state. In a preferred embodiment, balloon 850 is configured such that cowls 854 are urged radially away from elongate shaft 802 when balloon 850 is in the inflated state.

10 Figure 11 is a cross sectional plan view of catheter 800 of Figure 10. In Figure 11, a sensor 820 may be seen disposed within each flow channel 836. Each flow channel 836 is defined by a cowl 854 that is preferably fixed to balloon 850. Balloon 850 is disposed about elongate shaft 802.

In the embodiment of Figure 11, balloon 850 is disposed outside of a blood  
15 vessel, and is shown in an inflated state. Balloon 850 may be inflated, for example, by urging a fluid through an inflation lumen 860 and an inflation port 862 defined by elongate shaft 802.

Balloon 850 is preferably configured such that cowls 854 will be urged against the inner surface of a blood vessel when balloon 850 is placed in the inflated state  
20 while catheter 800 is disposed within the blood vessel. Balloon 850 is preferably configured such that blood flow around cowls 854 will be precluded when balloon 850 is in the inflated state.

Blood flowing proximate the inner surface of the blood vessel preferably flows through flow channels 836 defined by cowls 854. Sensors 820 may be used to

measure the temperature of the blood flowing through the channels. Blood which flows over a vulnerable plaque deposit will be warmed by the vulnerable plaque deposit. The increased temperature of this blood may be observed and/or recorded using sensors 820.

5           Figure 12 is a cross sectional plan view of a catheter 900 in accordance with yet another exemplary embodiment of the present invention. Catheter 900 comprises an elongate shaft 902 having an outer surface 906. A balloon 950 of catheter 900 is disposed about elongate shaft 902.

          Catheter 900 also includes a array 952 comprising plurality of cowls 954  
10       circumferentially disposed about balloon 950. In the embodiment of Figure 12, each cowl has a generally wedge shaped cross-sectional shape. Each cowl 954 is preferably fixed to balloon 950.

          Each cowl 954 defines a flow channel 936. A sensor 920 is preferably disposed within each flow channel 936. Each sensor 920 preferably comprises a  
15       temperature sensor. Examples of temperature sensors which may be suitable in some applications include resistance temperature devices (RTD's), thermistors, and thermocouples.

          Balloon 950 preferably has an inflated state and a deflated state. In the embodiment of Figure 12, balloon 950 is disposed within a blood vessel 20, and is  
20       shown in an inflated state. In a preferred embodiment, balloon 950 is configured such that cowls 954 are urged radially away from elongate shaft 902 when balloon 950 is in the inflated state. In Figure 12, it may be appreciated that cowls 954 have been urged against an inner surface 24 of blood vessel 20 by balloon 950. Balloon 950

may be inflated, for example, by urging a fluid through an inflation lumen 960 and an inflation port 962 defined by elongate shaft 902.

Balloon 950 is preferably configured such that blood flow around cowls 954 will be precluded when balloon 950 is in the inflated state. Blood flowing proximate  
5 inner surface 24 of blood vessel 20 preferably flows into flow channels 936 defined by cowls 954. Sensors 920 may be used to measure the temperature of the blood flowing through the channels. Blood which flows over a vulnerable plaque deposit will be warmed by the vulnerable plaque deposit. The increased temperature of this blood may be observed and/or recorded using sensors 920.

10 Having thus described the preferred embodiments of the present invention, those of skill in the art will readily appreciate that yet other embodiments may be made and used within the scope of the claims hereto attached. Numerous advantages of the invention covered by this document have been set forth in the foregoing description. It will be understood, however, that this disclosure is, in many respects,  
15 only illustrative. Changes may be made in details, particularly in matters of shape, size, and arrangement of parts without exceeding the scope of the invention. The invention's scope is, of course, defined in the language in which the appended claims are expressed.

What is claimed is:

1. A catheter for mapping vulnerable plaque deposits within a blood vessel, comprising;

an elongate shaft having a proximal end and a distal end;

at least one cowl fixed to the elongate shaft proximate the distal end thereof;

the at least one cowl defining an inlet port, an outlet port, and a flow channel extending therebetween; and

at least one temperature sensor disposed within the flow channel defined by the at least one cowl.

2. The catheter of claim 1, wherein the at least one temperature sensor is adapted to measure the temperature of blood passing through the flow channel.

3. The catheter of claim 1, wherein the at least one temperature sensor is adapted to measure the temperature of blood passing through the flow channel; and

the at least one cowl is configured such temperature of the blood passing through the flow channel is reflective of the temperature of inner surface of the blood vessel proximate the distal end of the catheter.

4. The catheter of claim 1, wherein the temperature sensor comprises a resistance temperature device.

5. The catheter of claim 1, wherein the temperature sensor comprises a thermocouple.

6. The catheter of claim 1, wherein the temperature sensor comprises a thermistor.
7. The catheter of claim 1, wherein the temperature sensor comprises a microbolometer.
8. The catheter of claim 1, further comprising an interstitial member disposed between the at least one cowl and the elongate shaft.
9. The catheter of claim 1, further comprising a balloon disposed between the at least one cowl and the elongate shaft.
10. The catheter of claim 1, wherein the balloon has an inflated state and a deflated state.
11. The catheter of claim 1, wherein the balloon is configured such that the flow of blood around the at least one cowl is precluded when the balloon is in the inflated state.
12. The catheter of claim 1, wherein the balloon is configured such that the at least one cowl urged radially away from the elongate shaft when the balloon is in the inflated state.

13. The catheter of claim 1, further comprising a plurality of cowls radially disposed about the elongate shaft.

14. A catheter for mapping vulnerable plaque deposits within a blood vessel, comprising;

an elongate shaft having a proximal end and a distal end;

a plurality of cowls radially disposed about the elongate shaft proximate the distal end thereof;

each cowl defining an inlet port, an outlet port, and a flow channel extending therebetween; and

a temperature sensor disposed within each flow channel.

15. The catheter of claim 14, wherein each temperature sensor comprises a resistance temperature device.

16. The catheter of claim 14, wherein each temperature sensor comprises a thermocouple.

17. The catheter of claim 14, wherein each temperature sensor comprises a thermistor.

18. The catheter of claim 14, wherein each temperature sensor comprises a microbolometer.

19. The catheter of claim 14, further comprising an interstitial member disposed between the cowls and the elongate shaft.

20. The catheter of claim 14, further comprising a balloon disposed between the at least one cowl and the elongate shaft.

21. The catheter of claim 20, wherein the balloon has an inflated state and a deflated state.

22. The catheter of claim 21, wherein the balloon is configured such that the flow of blood around the cowls is precluded when the balloon is in the inflated state.

23. The catheter of claim 21, wherein the balloon is configured such that the cowls urged radially away from the elongate shaft when the balloon is in the inflated state.

24. A catheter for mapping vulnerable plaque deposits within a blood vessel, comprising;

an elongate shaft having a proximal end and a distal end;

an array of cowls radially disposed about the elongate shaft proximate the distal end thereof;

each cowl of the array of cowls defining an inlet port, an outlet port, and a flow channel extending therebetween;

a temperature sensor disposed within each flow channel; and  
a means for radially expanding the array of cowls.

25. The catheter of claim 24, wherein each temperature sensor comprises a resistance temperature device.

26. The catheter of claim 24, wherein each temperature sensor comprises a thermocouple.

27. The catheter of claim 24, wherein each temperature sensor comprises a thermistor.

28. The catheter of claim 24, wherein each temperature sensor comprises a microbolometer.

29. The catheter of claim 24, wherein the means for radially expanding the array of cowls comprises a hydraulic mechanism.

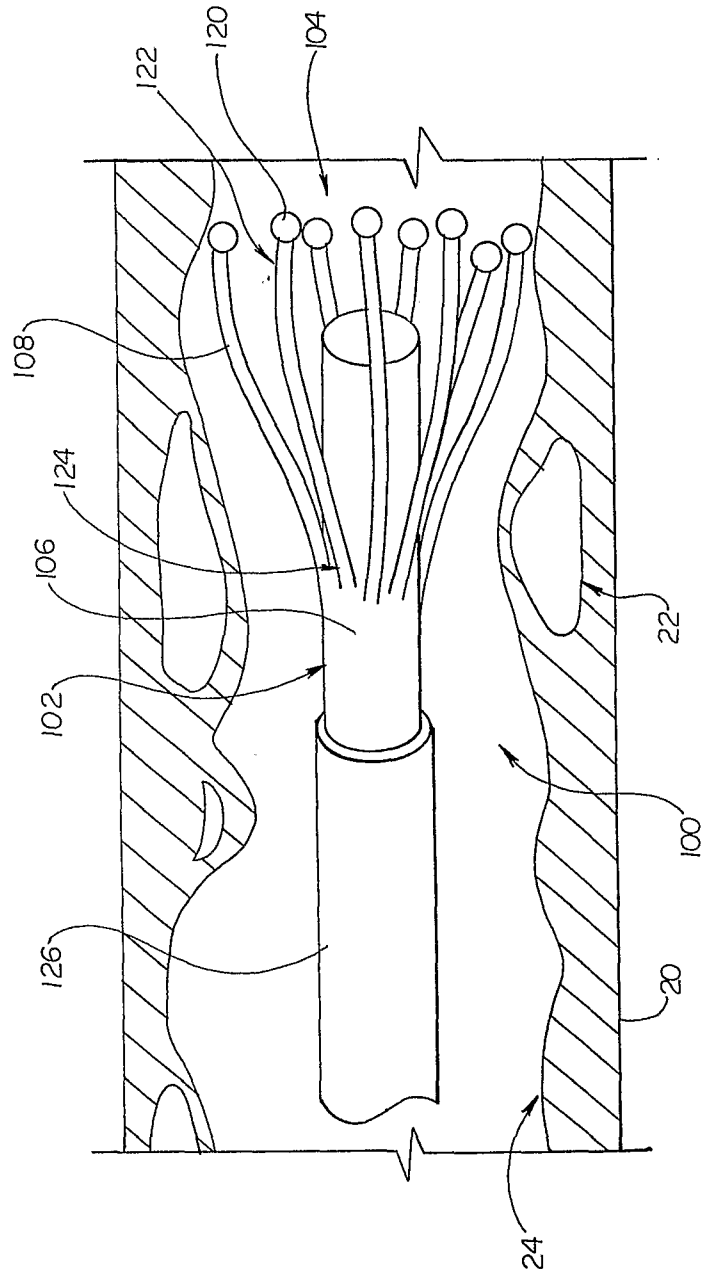
30. The catheter of claim 29, wherein the means for radially expanding the array of cowls comprises a balloon.

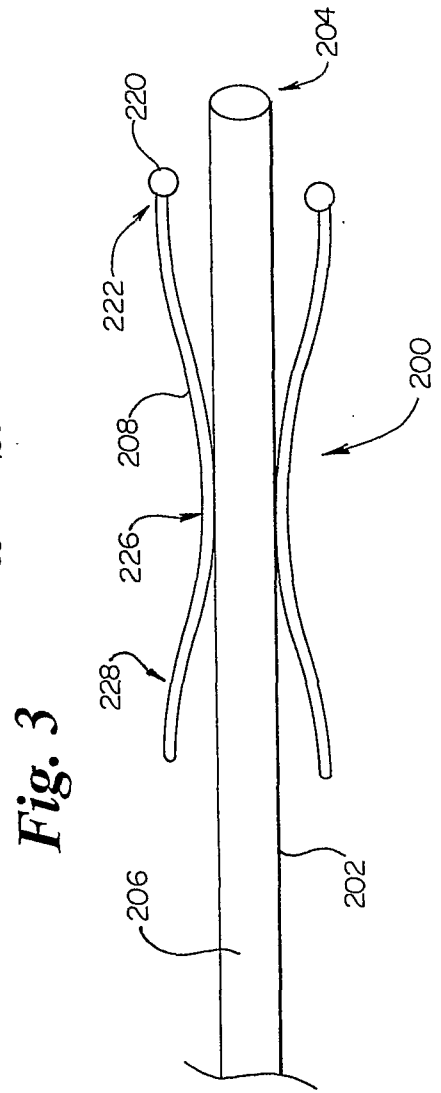
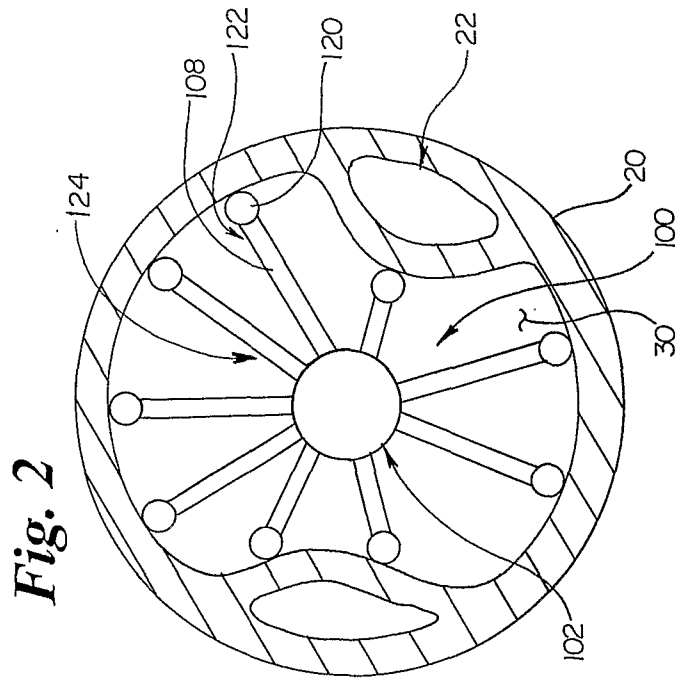
31. The catheter of claim 30, wherein the balloon is configured such that the flow of blood around the cowls is precluded when the balloon is in the inflated state.

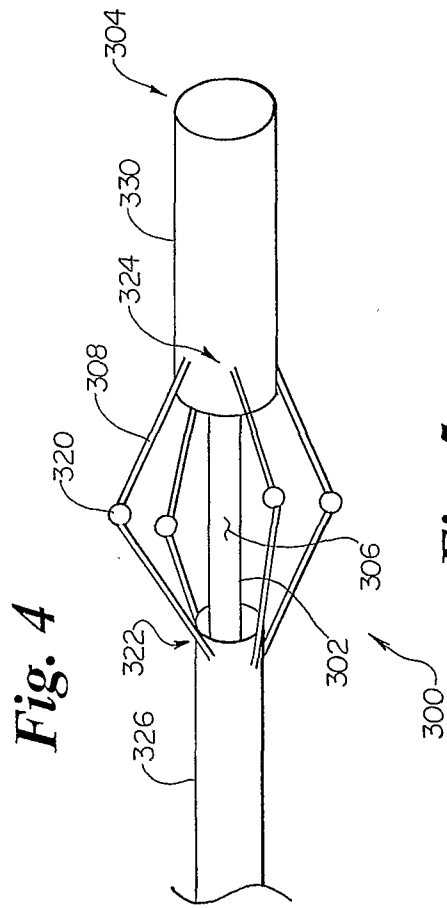
32. The catheter of claim 24, wherein the means for radially expanding the array of cowls comprises a mechanical mechanism.

33. The catheter of claim 29, wherein the means for radially expanding the array of cowls comprises a plurality of resilient arms.

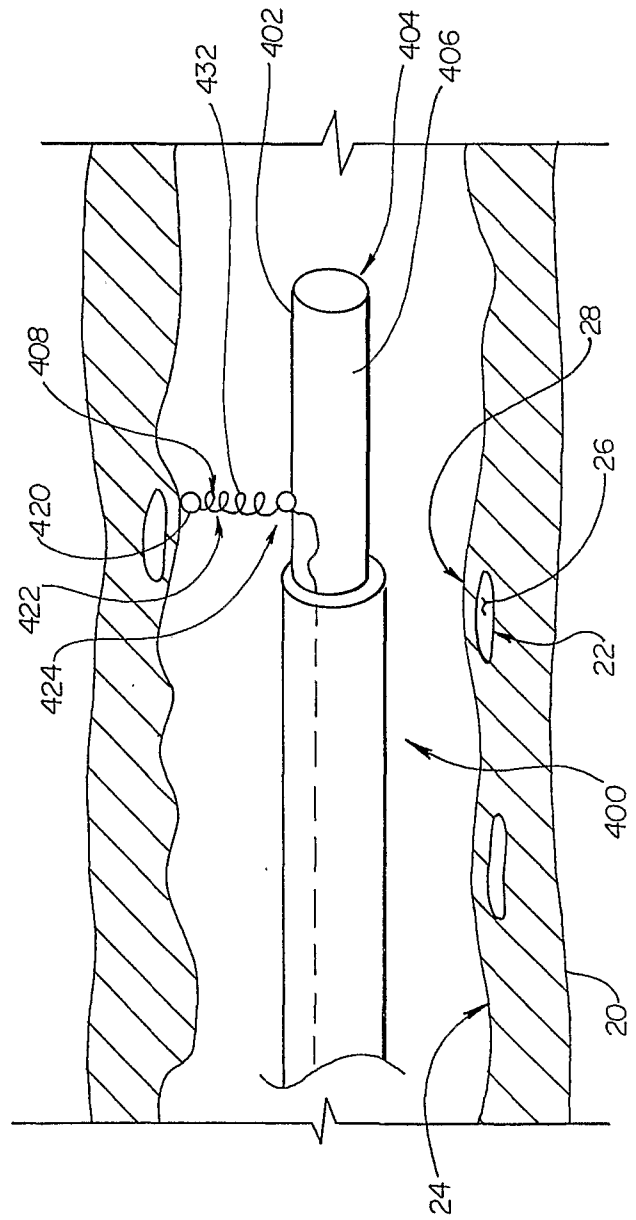
**Fig. 1**



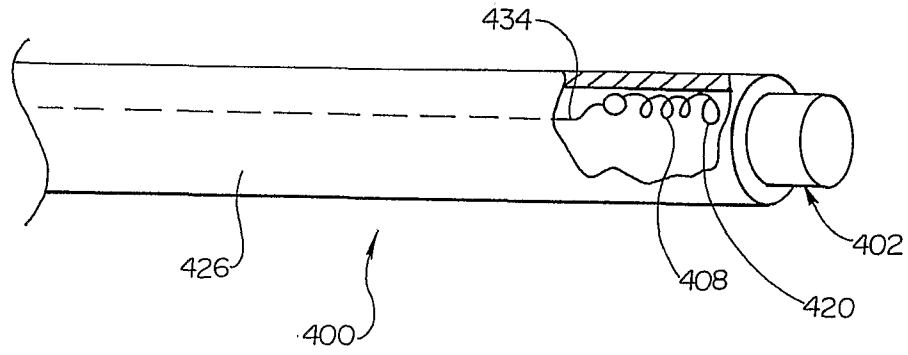




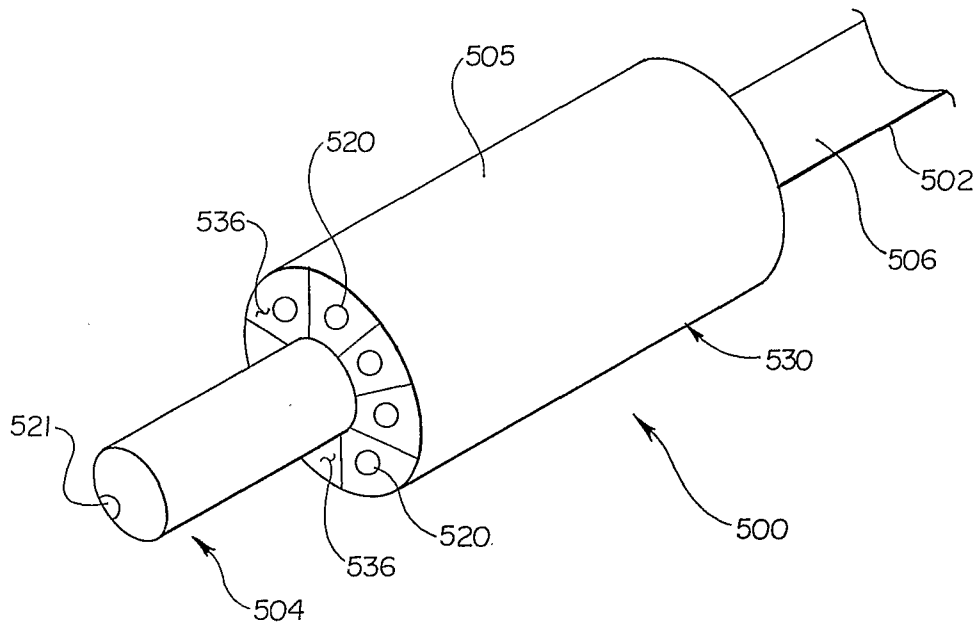
**Fig. 5**



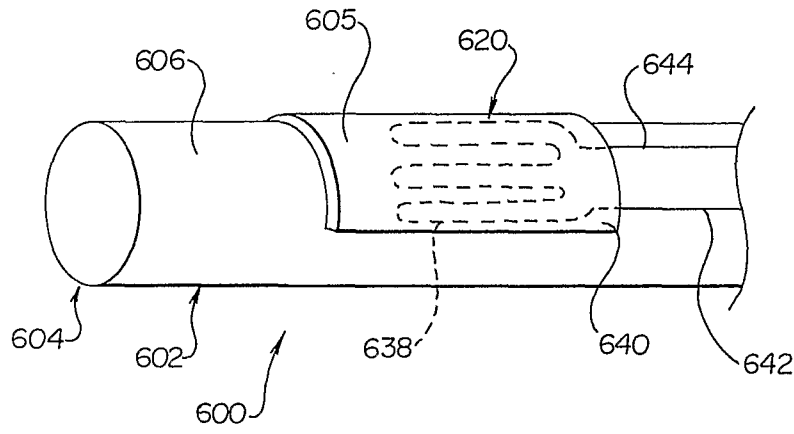
**Fig. 6**



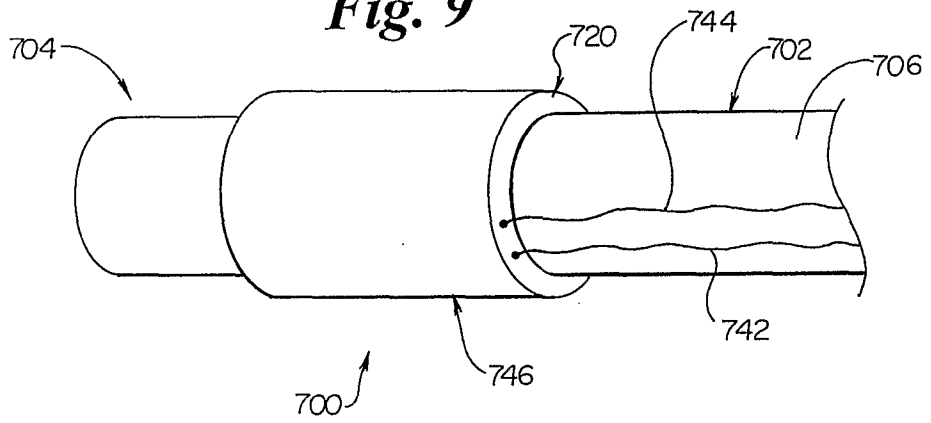
**Fig. 7**



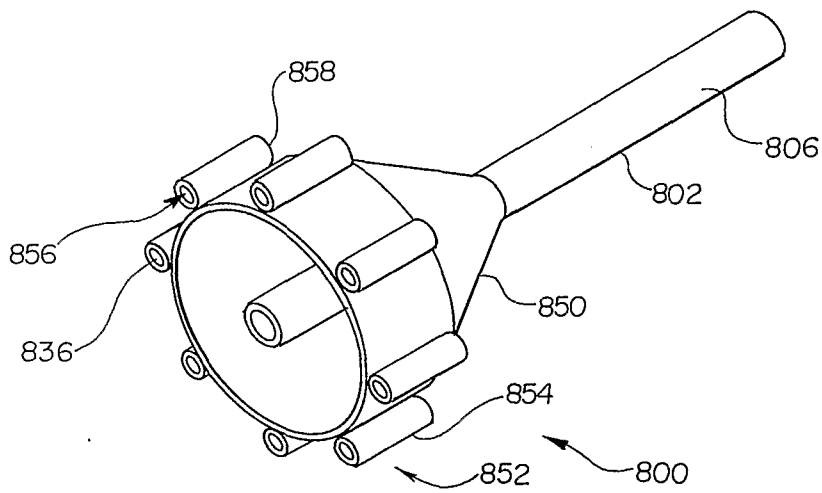
5/6  
**Fig. 8**



**Fig. 9**

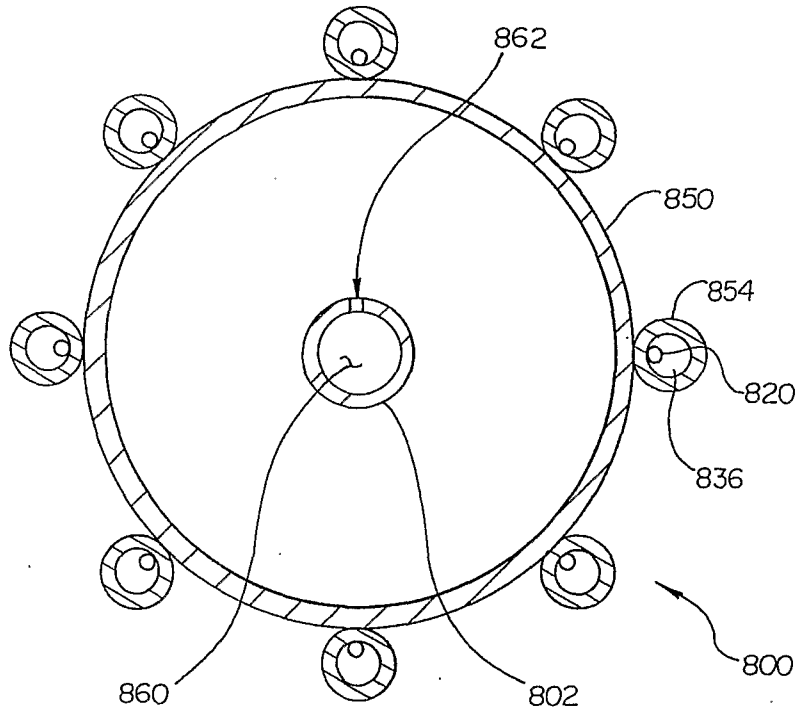


**Fig. 10**

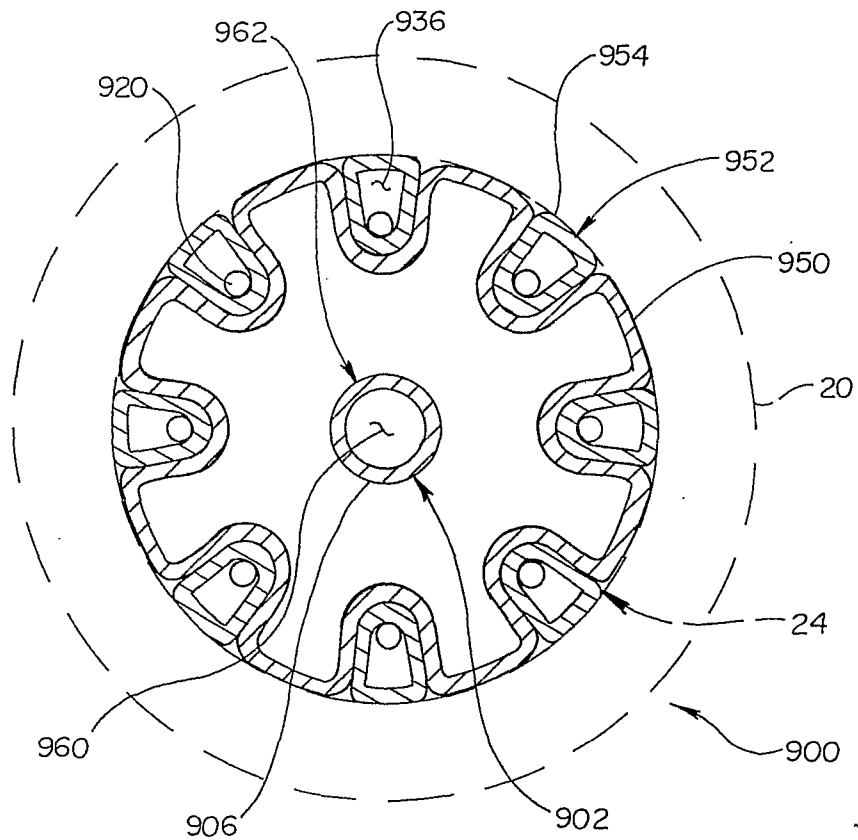


6/6

**Fig. 11**



**Fig. 12**



## INTERNATIONAL SEARCH REPORT

Int Application No  
PCT/US 02/03712**A. CLASSIFICATION OF SUBJECT MATTER**  
IPC 7 A61B5/00

According to International Patent Classification (IPC) or to both national classification and IPC

**B. FIELDS SEARCHED**

Minimum documentation searched (classification system followed by classification symbols)

IPC 7 A61B

Documentation searched other than minimum documentation to the extent that such documents are included in the fields searched

Electronic data base consulted during the international search (name of data base and, where practical, search terms used)

EPO-Internal, WPI Data, PAJ

**C. DOCUMENTS CONSIDERED TO BE RELEVANT**

Category °	Citation of document, with indication, where appropriate, of the relevant passages	Relevant to claim No.
A	EP 0 856 278 A (BROWN DAVID LLOYD) 5 August 1998 (1998-08-05) column 3, line 35 - line 46; figures 1,3,4 ---	1, 14, 24
A	WO 00 27278 A (CAMPBELL THOMAS H ; FARALLON MEDSYSTEMS INC (US); RAHDERT DAVID A ( ) 18 May 2000 (2000-05-18) column 5, line 8 - line 31; figures 1,3 ---	1, 14, 24
A	US 6 053 937 A (BURNS PATRICK J ET AL) 25 April 2000 (2000-04-25) column 5, line 11 - line 21; figure 1B -----	1, 14, 24

 Further documents are listed in the continuation of box C. Patent family members are listed in annex.

## ° Special categories of cited documents :

- \*A\* document defining the general state of the art which is not considered to be of particular relevance
- \*E\* earlier document but published on or after the international filing date
- \*L\* document which may throw doubts on priority claim(s) or which is cited to establish the publication date of another citation or other special reason (as specified)
- \*O\* document referring to an oral disclosure, use, exhibition or other means
- \*P\* document published prior to the international filing date but later than the priority date claimed

- \*T\* later document published after the international filing date or priority date and not in conflict with the application but cited to understand the principle or theory underlying the invention
- \*X\* document of particular relevance; the claimed invention cannot be considered novel or cannot be considered to involve an inventive step when the document is taken alone
- \*Y\* document of particular relevance; the claimed invention cannot be considered to involve an inventive step when the document is combined with one or more other such documents, such combination being obvious to a person skilled in the art.
- \* & \* document member of the same patent family

Date of the actual completion of the international search

30 May 2002

Date of mailing of the international search report

06/06/2002

Name and mailing address of the ISA

European Patent Office, P.B. 5818 Patentlaan 2  
NL - 2280 HV Rijswijk  
Tel. (+31-70) 340-2040, Tx. 31 651 epo nl,  
Fax: (+31-70) 340-3016

Authorized officer

Mayer, E

## INTERNATIONAL SEARCH REPORT

Information on patent family members

International Application No.

PCT/US 02/03712

Patent document cited in search report		Publication date	Patent family member(s)	Publication date
EP 0856278	A	05-08-1998	US 5871449 A	16-02-1999
			CA 2222399 A1	27-06-1998
			EP 0856278 A2	05-08-1998
			JP 10201718 A	04-08-1998
WO 0027278	A	18-05-2000	US 6245026 B1	12-06-2001
			AU 1715000 A	29-05-2000
			EP 1148812 A1	31-10-2001
			WO 0027278 A1	18-05-2000
US 6053937	A	25-04-2000	US 5800484 A	01-09-1998
			US 5728143 A	17-03-1998
			US 5683384 A	04-11-1997
			AU 2254397 A	02-09-1997
			CN 1211171 A	17-03-1999
			EP 0883379 A1	16-12-1998
			JP 2000507844 T	27-06-2000
			US 6132425 A	17-10-2000
			US 6080150 A	27-06-2000
			WO 9729702 A1	21-08-1997
			US 2002026185 A1	28-02-2002
			AU 6851096 A	12-03-1997
			AU 6851296 A	12-03-1997
			AU 6898196 A	12-03-1997
			AU 7007996 A	12-03-1997
			EP 0957988 A2	24-11-1999
			EP 0851743 A1	08-07-1998
			EP 0850024 A1	01-07-1998
			JP 11511988 T	19-10-1999
			JP 2000500033 T	11-01-2000
			JP 11511991 T	19-10-1999
			JP 11511992 T	19-10-1999
			JP 2001231790 A	28-08-2001
			KR 243503 B1	02-03-2000
			KR 243744 B1	02-03-2000
			NL 1003793 C2	02-05-1997
			NL 1003793 A1	18-02-1997
			US 5980517 A	09-11-1999
			WO 9706739 A2	27-02-1997
			WO 9706740 A2	27-02-1997
			WO 9706855 A2	27-02-1997
			WO 9706857 A2	27-02-1997
			US 6330478 B1	11-12-2001
			US 6235023 B1	22-05-2001
			US 5863290 A	26-01-1999
			US 5782827 A	21-07-1998
			US 5735847 A	07-04-1998
			US 5672173 A	30-09-1997
			US 5672174 A	30-09-1997
			US 5810804 A	22-09-1998
			US 2001001819 A1	24-05-2001
			US 6071280 A	06-06-2000
			US 5928229 A	27-07-1999
			US 5951547 A	14-09-1999
			US 5925042 A	20-07-1999
			US 5913855 A	22-06-1999
			US 6059780 A	09-05-2000
			US 6090105 A	18-07-2000

专利名称(译)	血管内温度传感器		
公开(公告)号	<a href="#">EP1359840A1</a>	公开(公告)日	2003-11-12
申请号	EP2002704384	申请日	2002-02-07
申请(专利权)人(译)	SCIMED LIFE SYSTEMS INC.		
当前申请(专利权)人(译)	BOSTON SCIENTIFIC LIMITED		
[标]发明人	KOKATE JAYDEEP Y DOBRAVA ERIC M BERRADA MARWANE S KIMMEL SCOTT PRSTIC SUZANA HOEY MICHAEL F BAR COHEN AVRAM IAIZZO PAUL A		
发明人	KOKATE, JAYDEEP, Y. DOBRAVA, ERIC, M. BERRADA, MARWANE, S. KIMMEL, SCOTT PRSTIC, SUZANA HOEY, MICHAEL, F. BAR-COHEN, AVRAM IAIZZO, PAUL, A.		
IPC分类号	A61B5/00 A61B5/01 A61B17/00 A61B17/22 A61F2/82		
CPC分类号	A61B5/01 A61B5/6852 A61B5/6853 A61B5/6858 A61B5/6859 A61B5/6885 A61B2017/00101 A61B2017/22051		
优先权	09/782502 2001-02-13 US		
其他公开文献	EP1359840B1		
外部链接	<a href="#">Espacenet</a>		

#### 摘要(译)

公开了用于检测血管内的易损斑块的装置和方法。根据本发明的导管包括细长轴，该细长轴具有近端，远端和外表面。至少一个温度传感器设置在细长轴的远端附近。在一个优选实施例中，所述至少一个温度传感器被引导以接触血管的内表面。在另一个优选实施例中，至少一个温度传感器设置在由主体构件限定的通道内，该主体构件围绕细长轴设置。