



(12) **EUROPEAN PATENT APPLICATION**

(43) Date of publication:
13.11.2019 Bulletin 2019/46

(51) Int Cl.:
G16H 50/30 (2018.01) **G16H 50/20 (2018.01)**
A61B 5/00 (2006.01) **A61B 5/0432 (2006.01)**
A61B 5/087 (2006.01) **A61B 5/1455 (2006.01)**

(21) Application number: **19161258.9**

(22) Date of filing: **13.02.2012**

(84) Designated Contracting States:
AL AT BE BG CH CY CZ DE DK EE ES FI FR GB GR HR HU IE IS IT LI LT LU LV MC MK MT NL NO PL PT RO RS SE SI SK SM TR

(72) Inventor: **AL-ALI, Ammar**
San Juan Capristano, CA 92675 (US)

(30) Priority: **13.02.2011 US 201161442264 P**

(74) Representative: **Vossius & Partner**
Patentanwälte Rechtsanwälte mbB
Siebertstrasse 3
81675 München (DE)

(62) Document number(s) of the earlier application(s) in accordance with Art. 76 EPC:
12705584.6 / 2 673 721

Remarks:

- This application was filed on 07-03-2019 as a divisional application to the application mentioned under INID code 62.
- Claims filed after the date of receipt of the divisional application (Rule 68(4) EPC).

(71) Applicant: **Masimo Corporation**
Irvine, CA 92618 (US)

(54) **MEDICAL RISK CHARACTERIZATION SYSTEM**

(57) A medical characterization system is configured to input medical-related continuous parameters and discrete data so as to calculate a characterization timeline indicative of a physiological condition of a living being. A data source is in sensor communications with a patient so as to generate a continuous parameter. The data source also provides test data responsive to the patient

at a test time. The test data is available to a characterization processor at a result time. The characterization processor is also responsive to the continuous parameter so as to generate a medical characterization as a function of time. A characterization analyzer enables the characterization processor to update the medical characterization in view of the test data as of the test time.

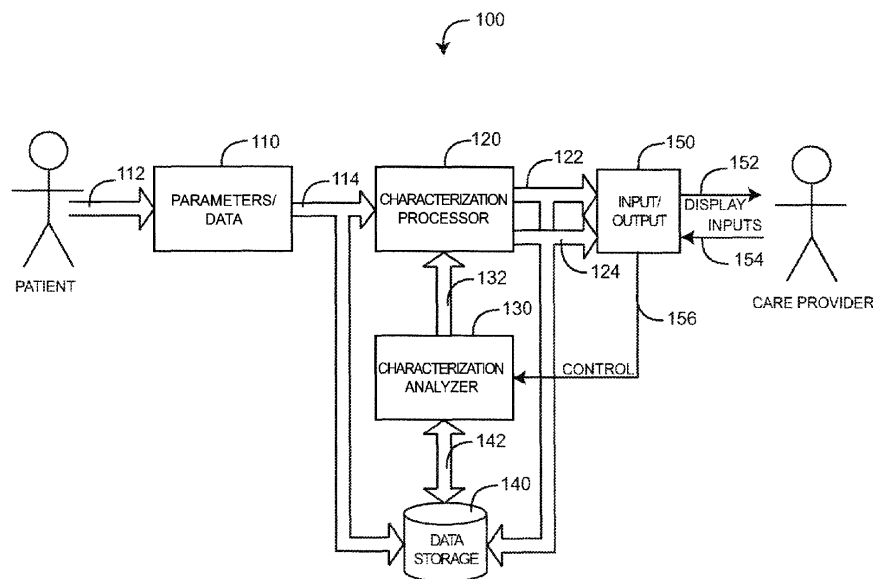

FIG. 1

Description

PRIORITY CLAIM TO RELATED PROVISIONAL APPLICATIONS

[0001] The present application claims priority benefit under 35 U.S.C. § 119(e) to U.S. Provisional Patent Application Serial No. 61/442,264 filed February 13, 2011, titled *Complex System Characterizer* hereby incorporated in its entirety by reference herein.

SUMMARY OF THE INVENTION

[0002] A typical multi-parameter patient monitoring system (MPMS) derives multiple medical-related parameters and displays the results as various combinations of readouts and waveforms. A MPMS is responsive to sensors attached to a patient and actively responds to the patient's physiology. Lacking, however, is the inclusion in patient monitoring of test measurements and other discrete data; previously recorded sensor data or parameters; and physiological data that has no particular time reference such as genetic information, family history and previous diagnoses, to name a few. Further, a MPMS does not provide a medical characterization of a patient that includes a time element associated with test measurements and other discrete data including the time a test is taken or the time span of a parameter recording. Further, MPMS information is not under dynamic user control so as to include or exclude information to determine overall impact on a patient characterization.

[0003] One aspect of a medical characterization system is configured to input medical-related continuous parameters and discrete data so as to calculate a characterization timeline indicative of a physiological condition of a living being. The medical characterization system has a parameter generator, a characterization processor, a discrete data source and a characterization analyzer. The parameter generator is in sensor communications with a living being so as to generate a continuous parameter. The characterization processor is responsive to the continuous parameter so as to generate a medical characterization of the living being as a function of time. The discrete data source provides a datum responsive to the living being at a first time and that is available to the characterization processor at a second time. A characterization analyzer enables the characterization processor to update the medical characterization in view of the datum as of the first time.

[0004] In various embodiments, the medical characterization system further comprises an analyzer model in communications with the characterization analyzer so as to determine the effect of the medical characterization update over time. The analyzer model comprises a selectable one of an upward shift, a downward aging and an upward ramp. A data storage is in communications with the data source and the characterization processor so that the characterization analyzer can selectively up-

date past portions of the medical characterization with later data. An input/output interface allows a person to selectively control the medical characterization updates. In an embodiment, the input/output interface has a display navigation tool that displays a selectable test epoch at the first time and a corresponding result epoch at the second time. In an embodiment, the analyzer model is responsive to one of a therapy time epoch and a test time epoch in view of a result epoch.

[0005] Another aspect of a medical characterization system are parameters generated in response to sensors in communication with a person. A medical characterization is calculated from the parameters that is generally indicative of the physiological condition of the person. A medical test is performed on the person at a test time. The medical test result is received at a later result time. The medical characterization is updated according to the medical test result as of the test time.

[0006] In various embodiments, the medical characterization models the behavior of the medical characterization over time in response to the medical test as a test model. The medical characterization is displayed as a function of time. The test time and the result time are indicated on the display as a test and result epochs, respectively. At least one of the test epoch and the result epoch are selected by a user so as to initiate the updating. The test model is applied to the medical characterization as of the test time in response to the selecting. A therapy time is indicated on the display as a therapy epoch. The behavior of the medical characterization over time in response to a therapy is modeled as therapy effectiveness. A therapy time is indicated on the display as a therapy epoch. The therapy epoch is selected, and the therapy effectiveness model is applied to the medical characterization as of the therapy time in response.

[0007] A further aspect of a medical characterization system is an apparatus comprising a data source, a characterization processor and a characterization analyzer. The data source provides both a continuous parameter timeline and a discrete test result responsive to the medical state of a living being at a test time. The characterization processor is in communications with the data source so as to calculate a medical characterization of the living being according to each of the continuous parameter and the discrete test result. The characterization analyzer updates the continuous parameter timeline according to the discrete test result as of the test time.

[0008] In various embodiments, the characterization processor, a processor engine and a processor model. The characterization processor has an input selector that allows a user to select a current data input or a sync data input as a medical data output. The processor engine inputs the medical data and generates a medical characterization. The processor model determines how the medical characterization is calculated based upon the medical data. The characterization analyzer has an analyzer engine that combines current medical data and recalled medical data to generate sync data according

to an analyzer model. A graphics generator outputs the medical characterization to a display. A marker generator indicates test and result epochs on the display in conjunction with the medical characterization. An analyzer model determines the effect of a test result on the medical characterization. The analyzer model further indicates the effectiveness of an earlier therapy based upon the test result.

[0009] Advantageously, a medical characterization system is configured to input real-time and non-real-time discrete and continuous medical-related parameters and data so as to calculate, in an embodiment, a risk timeline indicative of a probability of serious illness or death due to injury, disease or other physiological conditions. The risk timeline is dynamically updated over past time segments as well as present time to account for newly received or previously unused parameters and data. In an embodiment, the medical characterization system has a parameter generator in sensor communications with a patient so as to generate continuous data streams indicative of the patient's physiological condition. A risk processor responsive to the parameter generator generates a risk timeline. A risk analyzer controls the risk processor so as to modify the risk timeline over past time segments as well as present time according to new information regarding the patient, such as medical tests, diagnoses and therapies, to name a few. The risk analyzer relates this new information back to the time that the information originated. Further a medical characterization system advantageously allows a user to dynamically include or exclude individual parameters or data or selected groups of parameters and data so as to determine the impact on the risk timeline, both past and present.

[0010] Although an embodiment of a medical characterization system is described with respect to calculating and generating a dynamically adjustable medical risk characterization timeline, in other embodiments a medical characterization can reflect any of a variety of medical characteristics, both general and specific, such as wellness, fitness or competitive readiness of athletes, to name a few. Further, although an embodiment of a medical characterization system is described with respect to a single risk timeline, in other embodiments a medical characterization system can calculate and simultaneously display multiple characteristics concurrently. For example, in addition to or instead of an overall risk timeline, the characterization can be multiple particularized risk timelines, such as an array of risks to a person's circulatory, respiratory, neurological, gastrointestinal, urinary, immune, musculoskeletal, endocrine or reproductive systems.

DESCRIPTION OF THE DRAWINGS

[0011]

FIG. 1 is a general block diagram of a medical characterization system;

FIGS. 2A-C are graphs of a medical characterization versus time, which generally illustrate medical characterization;

FIG. 3 is detailed block diagram of a medical data source embodiment;

FIG. 4 is a detailed block diagram of a characterization processor embodiment;

FIG. 5 is a detailed block diagram of a characterization analyzer embodiment;

FIG. 6 is a detailed block diagram of an input/output (I/O) interface embodiment;

FIGS. 7A-D are graphs of exemplar analyzer models versus time;

FIGS. 8A-D are exemplar characterization versus time displays illustrating a navigation tool for analyzing medical characterizations;

FIG. 9 is a detailed block diagram of a risk characterization system embodiment;

FIG. 10 is a flow diagram of a risk processor embodiment;

FIG. 11 is a flow diagram of a subparameter risk calculator embodiment;

FIG. 12 is a flow diagram of a parameter risk calculator embodiment;

FIG. 13 is a block diagram of a risk analyzer embodiment; and

FIG. 14 is a block diagram of an I/O interface embodiment.

30 DETAILED DESCRIPTION OF THE PREFERRED EMBODIMENTS

[0012] **FIG. 1** generally illustrates a medical characterization system 100, which provides a medical characterization of a living being, such as a patient or person under medical care. The medical characterization system 100 has data sources 110, a characterization processor 120, a characterization analyzer 130, data storage 140 and I/O (input/output) 150. Data sources 110 include various sensors and monitors in communications 112 with a patient so as to generate parameters or transmit data. Data sources 110 further include discrete data such as test results. As such, data sources 110 generally provide parameters, test data and other information 114 indicative of one or more aspects of the patient. The characterization processor 120 is responsive to the data sources 110 so as to derive a medical characterization 122. In an embodiment, the medical characterization is a wellness or a risk index. The characterization processor 120 also generates epochs 124 indicating discrete data, as described with respect to FIG. 4, below. The characterization analyzer 130 advantageously updates and synchronizes the characterization 122 so that it is accurate across all time periods of interest. Also, the characterization analyzer 130 generates different versions or realities of the medical characterization 122 based upon the inclusion or exclusion of available parameters and data 114. This advantageously allows a care provider or other user to

determine the impact of that information 114 on the medical characterization 122.

[0013] FIGS. 2A-C generally illustrates functional aspects of a characterization analyzer 130 (FIG. 1). A characterization processor 120 (FIG. 1) generates an initial medical characterization 210 in response to data sources 110 (FIG. 1), which is illustrated in a medical characterization versus time graph 201 up to a present time 228. The characterization analyzer 130 (FIG. 1) in conjunction with the characterization processor 120 (FIG. 1) also generates one or more updated characterizations 220 in response to a data source 110. A particular updated characterization 220 may provide an updated portion 222 and retain a relatively instantaneous portion 224 of the initial characterization 210. In various embodiments, the updated portion 222 may extend to present time 228 such that the instantaneous portion 224 is negligible.

[0014] As shown in **FIG. 2A**, an initial medical characterization 210 may only be accurate as of the current time 228. As such, it is difficult for a care provider to accurately assess an individual's medical condition over a period of time based upon this information alone. In particular, the historical values 212 may well be out-of-date as more information about the individual is received. This is particularly true if newly received information is not instantaneous, i.e. pertains to a past time. The characterization analyzer 130 (FIG. 1) advantageously generates one or more updates of the initial medical characterization 210 over some or all of the characterization time record so as to take into account not only the patient history but also newly gained information that relates back in time. The characterization analyzer 130 (FIG. 1) generates one or more of these characterization updates 222 as the characterization processor 120 (FIG. 1) continues to provide instantaneous characterizations 210. Further, a medical characterizer system 100 (FIG. 1) embodiment has data storage 140 (FIG. 1) that advantageously records the initial characterization 210 and any or all subsequent updated characterizations 220 for playback so that the impact of newly received information may be reviewed and analyzed at the characterization processor output 122.

[0015] As shown in **FIG. 2B**, in a medical characterization versus time graph, an initial medical characterization 230 is generated by the characterization processor 120 (FIG. 1). In an exemplar embodiment, the medical characterization 230 incorporates several parameters P1, P2 and P3. However, P1 has a processing time t1 245, P2 has a processing time t2 247 and P3 has a processing time t3 249. If these processing times are not insignificantly short, the initial risk characterization 230 may not be accurate. In particular, the parameters P1-P3 may not be applicable to the present time 228, but rather relate back by the individual computation times 245-249. The characterization analyzer 130 (FIG. 1) advantageously calculates an updated characterization 242 that relates-back each parameter by its particular processing time 245-249. Accordingly, the updated char-

acterization 240 has an updated portion 242 and an instantaneous portion 244, as generally described with respect to FIG. 2A, above. The updated portion 242 advantageously takes into account all parameter processing times 245-249. The instantaneous portion 244 may be ambiguous until the processing time issues are resolved.

[0016] As shown in **FIG. 2C**, an initial medical characterization 250 is generated by the characterization processor 120 (FIG. 1). At a specific time 252, a patient test is initiated. This may be a blood test, urinalysis, x-rays or physical exam to name just a few. At some later time 254, the characterization processor 120 (FIG. 1) receives the test results. However, the test results are not applicable to the time received 254 but rather to the test time 252. The characterization analyzer 130 (FIG. 1) in conjunction with the characterization processor 120 (FIG. 1) advantageously generate an updated medical characterization 264 having a historical portion 262 and an updated portion 264. The historical portion 262 remains unchanged from the initial characterization 250. The updated portion 264, however, advantageously relates the test result 254 back to the test time 252. As such, the updated characterization 264 provides a care provider an accurate representation of an individual's medical status, such as risk or wellness, to name a few. Further, the care provider can advantageously compare the initial 250 and updated 260 medical characterizations to determine the full impact over time of the test result 254 on the individual's status.

[0017] FIG. 3 illustrates an exemplar medical data source 300 that is in communications with a living being such as a patient 30 so as to output information including parameters 301 and data 302 used to generate a medical characterization. One or more sensors 310 are in contact with the subject 30 so as to generate continuous physiological information, such as information that is a continuous function of time over a particular time segment and that regards the subject's physiological condition. One or more monitors 330 may be in communications with the sensors 310 so as to calculate parameters 301. Parameters 301 are typically realtime, continuous information generated from sensors 310 and corresponding monitors 330, or sensors 310 alone, and are accordingly immediately responsive (taking into account monitor processing times) to events occurring in realtime with the patient 30. Parameters 301 may also include segments of sensor 310 and monitor 330 outputs which are recorded on a variety of analog and digital devices including magnetic tape and disks, semiconductor memories and optical storage devices, to name a few examples, and played-back at a later time. Sensors 310 may include optical sensors, such as pulse oximetry sensors; acoustic sensors, such as piezoelectric devices; blood pressure sensors, such as an inflatable cuff incorporating an audio transducer; airflow sensors and electrodes, to name just a few. Monitors 330 may include pulse oximeters, advanced blood parameter monitors, acoustic monitors and

capnography monitors, as examples. Recording devices may include specialty devices, such as a Holter monitor for recording an ECG signal, or any general data recording mechanism, such as semiconductor memory, magnetic disks, optical disks and the like.

[0018] Also shown in **FIG. 3**, one or more data sources 360 having medical-related information generate discrete information 302. The discrete information may be associated with a particular point in time (realtime data 370), or not associated with any particular point in time (non-realtime data 380). Realtime data 370 may include laboratory work, such as blood tests, urinalyses, X-rays or MRIs to name a few, which generate results that can relate back to respective test times. Non-realtime information 380 is typically gathered from a variety of sources and stored and accessed via one or more databases. Databases may range from a centralized database administered by a single organization/entity to a number of distributed and disparate databases administered by a variety of organizations/entities. Non-realtime data 380 may include a subject's 30 medical history and pharmacological, genetic and environmental data, for example, which are not associated with any particular time or date or are too remote in time to relate back to any realtime parameters of interest.

[0019] **FIG. 4** illustrates a characterization processor 400 embodiment having an input selector 410, a processor engine 420 and processor models 430. The input selector 410 allows a care provider or other user to select current medical data 114 including parameters derived from sensors and monitors and data derived from lab work and external databases. The input selector 410 also allows the care provider to select sync data 132 generated by the analyzer engine 510 (**FIG. 5**), as described below. In particular, the input selector 410 may generate a medical data 412 output to the processor engine 420 having current data 114 or sync data 132, which is a combination of current and recalled data. In this matter, a care provider may request a medical characterization 122 based upon current information, such as a blood test result, related back to the time the blood was drawn. This advantageously allows the blood test to be synchronized with parameters and other medical data at the time blood was drawn as opposed to the potentially much later time when the blood was tested and the test results were made available. This back-in-time synchronization of new results with recalled data is described in further detail with respect to **FIGS. 7-8**, below. Further, a care provider can generate multiple characterizations of various combinations of current data 114, including or excluding various parameters or tests, say, so as to determine the effect on the medical characterization 122.

[0020] Also shown in **FIG. 4**, processor models 430 determine what medical characterization 122 is derived and how the derivation is calculated. In an embodiment, the medical characterization 122 is a risk parameter, which advantageously provides a care provider with a real-time index indicative of, in one embodiment, the

physiologic deterioration in a patient. A risk characterization is described in further detail with respect to **FIGS. 9-14**, below. Risk model embodiments for deriving a risk characterization are described with respect to **FIGS. 11-12**, below.

[0021] **FIG. 5** illustrates a characterization analyzer 500 embodiment having an analyzer engine 510 and analyzer models 520. The analyzer engine 510 inputs current and recalled data 142 so as to generate a synchronized (sync) data 132 output. Sync data 132 represents the time synchronization of current (new) data 114 (**FIG. 1**) with recalled (older) data 142 (**FIG. 1**), where, for example, the current data is used to update the recalled data so as to advantageously match a test result received at a later time with medical data generated when the test was taken. Such data synchronization is described in further detail with respect to **FIGS. 8A-D**, below. The analyzer models 520 determine the manner in which current data is combined with recalled data. Various analyzer models are described with respect to **FIGS. 7A-D**, below.

[0022] **FIG. 6** illustrates an input/output (I/O) 600 embodiment having a graphics generator 610, a display driver 620, a marker generator 630 and a control interface 640. Generally, the I/O 600 inputs characterizations 122 and discrete data 124 from the characterization processor 122, which are graphically displayed 622 via the display driver 620. In particular, the graphics generator 610 outputs a characterization curve 612 interspersed with discrete variable epochs 632, as described below with respect to **FIGS. 8A-B**. The display driver 620 generates a display output 622 to any of various standard displays, such as a flat screen monitor, so as to visually present the combined characterization curve 612 and epochs 632 to a care provider or other user. The care provider selects one or more epochs 632 via controls 154, such as a keypad, mouse or trackball, to name a few. The control interface generates user selects 644 in response to the controls 154. The marker generator 630 is responsive to the user selects 644 to mark the selected epochs 632, which also notifies the characterization analyzer accordingly.

[0023] **FIGS. 7A-D** illustrate exemplar characterization analyzer models. As described with respect to **FIG. 5**, above, a characterization analyzer advantageously time synchronizes previously known medical information with updated medical information so that a characterization processor may accurately derive and display a medical characterization of a patient for evaluation by a care provider. An advantageous aspect of characterization analysis is the accurate modeling, analysis and display of a medical characterization so as to compensate for the time delay between a data measurement and a data result, as generally described with respect to **FIGS. 2A-C**, above.

[0024] **FIG. 7A** graphs a parameter 711, a shift model 712, a medical characterization 713 and an adjusted medical characterization 714. The parameter graph 711 depicts a parameter measurement 730 at a test time 721

yielding a result at a result time 722. The model graph 712 depicts a medical characterization modeled as a step change or shift in the characterization 723 at the test time 721. The characterization graph 713 depicts a medical characterization 724 based upon the parameter 711 before the result 722 is known. The adjusted characterization graph 714 depicts the medical characterization before 724 and after 725 the modeled shift 723. For example, the parameter 711 may be Hb. The test may be a blood draw indicating an abnormally low hemoglobin. The characterization 713 and adjusted characterization 714 may be medical risk (see FIGS. 9-14, below), so as to indicate a step change in risk 724, 725 at the time of the test 721 as compared with the time of the test result 722.

[0025] FIG. 7B graphs a parameter 731, an aging model 732, a medical characterization 733 and an adjusted medical characterization 734. The parameter graph 731 depicts a parameter measurement 740 at a test time 741 yielding a result at a result time 742. The model graph 732 depicts a medical characterization modeled as an aging, i.e. a step change or shift in the characterization 743 at the test time 741 followed by a decreasing change 744 over time. The characterization graph 733 depicts a medical characterization 745 based upon the parameter 731 before the result 742 is known. The adjusted characterization graph 734 depicts the medical characterization before 746 and after 747 the modeled aging 743, 744. For example, the parameter 731 may be body temperature. The test may be a white blood cell count blood draw indicating a possible infection. The characterization 733 and adjusted characterization 734 may be medical risk so as to indicate an initial increase in risk 746, 747 at the time of the test 741, which diminishes over time as the result of known treatments or the fact that the test result becomes old and increasingly unreliable over time.

[0026] FIG. 7C graphs a parameter 751, a ramp model 752, a medical characterization 753 and an adjusted medical characterization 754. The parameter graph 751 depicts parameter measurements 760, 761 at a test times 762, 763 yielding results at result times 764, 765. The model graph 752 depicts a medical characterization modeled as a ramp-up 766, i.e. an increasing characterization at test time 762 that levels off 767 at test time 763 or continues to increase 768. The characterization graph 753 depicts a medical characterization 770 based upon the parameter 751 before the results 764, 765 are known. The adjusted characterization graph 754 depicts the medical characterization before 771 and after 772 the modeled ramp 766, 767. For example, the parameter 751 may be blood pressure. The test may be blood draws indicating Hct levels are decreasing over time. The characterization 753 and adjusted characterization 754 may be medical risk so as to indicate an increasing risk 771, 772 over time 762, 763.

[0027] FIG. 7D graphs a parameter 781, an effectivity model 782, a medical characterization 783 and an adjusted medical characterization 784. The parameter

graph 781 depicts therapy 792 applied at a time 791 and a follow-up test 794 at a time 793 with a result at time 795. A first model graph 782 depicts a medical characterization modeled as an characterization decrease 796 over time, which depicts an effective therapy based upon the test results 795. A second model graph 783 depicts a medical characterization modeled as an characterization increase 797 over time, which depicts an ineffective therapy based upon the test results 794. The characterization graph 784 depicts a medical characterization 790 based upon the parameter 781 before the result 795 is known. The adjusted characterization graphs 798, 799 depict the medical characterization applied at the time of the therapy 791, assuming an effective 798 or ineffective 799 therapy, respectively. For example, the therapy may be administration of antibiotic and the test may be throat culture. Advantageously, the various models allow a medical characterization, such as risk, to be accurately reflected as of the time of a test or as of the time of an applied therapy, as examples. Further, the models advantageously allow the medical characterization to be modeled back in time in a variety of ways depending on the parameter measured, the type of test, the number of tests and therapies applied. These models may variously reflect characterization shifts, aging, ramps as examples. In other embodiments, multiple tests may allow a characterization model to be a parametric curve depending on the test times and results.

[0028] FIG. 8A-B illustrates a display navigation tool (DVT) 800 that user I/O 150 (FIG. 1) generates on a user display 152 (FIG. 1). The DVT advantageously allows a care provider or other user to selectively control the incorporation of test data into a medical characterization of a patient or other living being. In particular, a characterization processor 120 (FIG. 1) generates a characterization 122 output, which is viewed as a characterization 801 timeline on the user display. Advantageously, user I/O superimposes discrete test epochs 812-816 and corresponding result epochs 822-826 on the characterization 801 timeline so that a user can selectively incorporate discrete test data into characterization calculations. In an embodiment, the characterization is a measure of risk.

[0029] As shown in **FIG. 8A**, in a particularly advantageous embodiment, test and result epochs 805, 806 are displayed as paired flags. A first set of flags 805 indicate tests and a second set of flags indicate results. In an embodiment, the test flags 805 extend above the characterization 801 timeline and result flags 806 extend below the characterization 801 timeline. In this manner, a user viewing the display can readily determine the time a test occurs and the time a corresponding result is received. In an embodiment, test/result pairs (e.g. 812/822; 814/824 and 816/826) are shown with unique matching flags so that a user viewing the display can readily determine matching pairs and distinguish them from other matching pairs.

[0030] As shown in **FIG. 8B**, a selected test flag 814 and corresponding test result flag 824 are indicated on

the display by holding, coloring or otherwise highlighting the flag pair 814/824. Once a particular pair is selected, a user can initiate a characterization recalculation, as described with respect to FIGS. 1-7, above. The characterization recalculation modifies the characterization timeline to account for the test data, and this modification relates back to the test epoch. A corresponding characterization recharacterization 802 timeline is displayed, where the test result 824 at time t_f relates back to the test time t_i . The characterization recharacterization generates an updated characterization 851 timeline portion and a historical (unchanged) characterization 850 timeline portion.

[0031] In an embodiment, a user temporarily positions a cursor (via a mouse or other pointing device) over a test or result so as to trigger a pop-up that provides a written description of the test or result. The description may indicate the kind of test (e.g. blood analysis, x-ray, urinalysis, etc.); the time and date of the test and result; the test source, such as a specific laboratory; and the physician in charge, to name just a few. Multiple test/result pairs may be selected so as to allow a user to see the impact on the characterization of multiple groups of tests. In other embodiments, not shown, non-realtime data including personal history (e.g. smoking, alcohol or drug abuse); medical history (e.g. cancer, heart disease, congenital defects); family history; personal genome data, among many others, are listed on demand and selectable individually or in groups so as to recharacterize risk accordingly.

[0032] As shown in **FIG. 8C**, in a particularly advantageous embodiment, multiple related test and result epochs 824-838 are displayed with matching flags and can be simultaneously selected so as to trigger multi-point characterization models relating back to multiple tests 824, 826. As shown in **FIG. 8D**, a selected set of therapy and test flags 832-836 and corresponding result flags 836, 838 are indicated on the display by bolding, coloring or otherwise highlighting the flag sets 832/834/836. Once a particular set is selected, a user can initiate a characterization recalculation, as described with respect to FIGS. 7A-D, above. The characterization recalculation modifies the characterization timeline to account for the therapy and/or test data, and this modification relates back to a therapy or test epoch. A corresponding recharacterization 804 timeline is displayed, where the test result 836 at time t_4 relates back to a test time t_2 , a therapy time t_1 or a combination of test or therapy times.

[0033] **FIG. 9** illustrates a medical risk system 900 embodiment of a medical characterization system. Generally, the medical risk system 900 characterizes a person with respect to their physiological wellness or illness. In an embodiment, the medical risk system 900 advantageously indicates a potential for near-term serious physiological impairment or death due any one or more of disease, injury, surgical complications, drug side-effects or allergic reactions, to name just a few.

[0034] As shown in **FIG. 9**, medical risk system 900

has a parameter generator 910, a risk processor 1000, user input/output 920, data storage 930 and a risk analyzer 1000 all communicating over a common network 5. Generally, the parameter generator 910 is in communications with a patient 30 and various information sources 40 regarding the patient so as to generate parameters and data 912 (collectively "medical data") indicative of a patient's medical state. This data 912 is stored as one or more records 934 in the data storage 930. The risk processor 1000 is responsive to the data 934 so as to generate a risk 1001 output, indicative of the patient's medical risk. Risk 1001 is stored as one or more risk records 936 in the data storage 930. In an embodiment, risk 1001 is a function of time having a high value if a person is at a high risk of an impending serious or life-threatening physiological event and a low value if a person has a correspondingly low risk of such an event. In an embodiment, the risk processor 1000 functions in conjunction with the risk analyzer 1300 to update risk records 936 with new data 912 so as to generate additional risk records 936, as described with respect to FIGS. 10-14, below. User I/O 920 allows doctors, medical staff, researchers and other care providers 50 to review and accurately modify risk records 936, to assess the impact on medical risk of newly obtain patient data 912 and to control the functions of the risk processor 1000 and risk analyzer 1300.

[0035] A wellness analysis system that integrates real-time sensor data from a patient or other subject regarding the status of any or all of a subject's circulatory, respiratory, neurological, gastrointestinal, urinary, immune, musculoskeletal, endocrine and reproductive systems and non-real-time information regarding the subject such as a lab work, pharmaceuticals and medications, medical history, genetics and environment from hospital records and other databases so as to generate a current or predictive wellness index or related output is described in U.S. Pat. App. No. 13/009,505, filed 01/19/2011, titled *Wellness Analysis System*, assigned to Masimo Corporation, Irvine Corporation ("Masimo") and hereby incorporated by reference herein. A risk analysis system that inputs sensor data from a subject, derives corresponding physiological parameters, assesses parameter risks according to parameter values and the impact those values have on the subject's physiology and estimates a total risk from a combination of the parameter risks, where total risk is a numerical indication of the likelihood of serious illness or debilitation or, in contrast, the likelihood of wellness or health is described in U.S. Patent App. No. 13/269,296, filed 10/07/2011, titled *Risk Analysis System*, assigned to Masimo and hereby incorporated by reference herein.

[0036] **FIG. 10** illustrates a medical risk processor 1000 embodiment having input parameters 1001 and generating a risk 1003 output. The risk processor 1000 has a parameter risk calculator 1010, a total risk calculator 1020 and a risk calculation controller 1030. The parameter risk calculator 1010 inputs parameters 1001 and generates corresponding parameter risks 1011. The total

risk calculator 1020 inputs the parameter risks 1011 and generates the risk 1003 output. The risk calculation controller 1030 advantageously modifies the parameter risks 1101 and the risk 1003 in response to controls 1002 from the risk analyzer 1000 (FIG. 10). Controls 1024 allow the risk analyzer 1303 (FIG. 13) to dynamically modify risk 701 in response to changes in the monitored parameters, new test results or data updates pertaining to the subject monitored.

[0037] As shown in FIG. 10, controls 1002 may indicate which parameters 1001 are active, what discrete real-time data, such as lab work, is available and what non-real-time data, such as medical history, is available. The risk calculation controller 1030 responds to the controls 1002 so as to generate sub-parameter adjusts 1032 to the parameter risk calculation 1010, as described with respect to FIG. 11, below. The risk calculation controller 1030 also responds to the controls 1002 so as to generate risk adjusts 1034 to the total risk calculation 1020, as described with respect to FIG. 12, below.

[0038] FIG. 11 illustrates a parameter risk calculator 1100 having input parameters $PARA_1$ - $PARA_N$ 1101 and output parameter risks $PARA_1$ RISK- $PARA_N$ RISK 1103. Each of the parameter risks 1103 is calculated independent of the others. Detailed in FIG. 11 is a risk calculation for $PARA_M$ 1105, which yields $PARA_M$ RISK 1180. Initially, sub-parameter calculators 1110 factor $PARA_M$ 1105 into a corresponding set of sub-parameters $SUBP_1$ - $SUBP_n$ 1120. In particular, the sub-parameters calculators 1110 are each responsive to a particular feature of the parameter 1105. Generally, these features are chosen so that the corresponding sub-parameter risks $SUBP_1$ RISK- $SUBP_n$ RISK 1140, as a set, are representative of the risk associated with the particular input parameter $PARA_M$ 1105. For example, an oxygen saturation parameter might be factored into the sub-parameters saturation baseline, saturation instability and saturation average slope.

[0039] As shown in FIG. 11, sub-parameter risk calculators 1130 derive sub-parameters risks 1140 from the sub-parameters 1120. A sub-parameter risk calculator 1130 is a risk versus parameter value function (illustrated graphically herein). Accordingly, each sub-parameter risk calculator 1130 converts sub-parameter 1120 values into risks ranging between 0 to 1 (0% to 100% risk) according to the physiological characteristic represented by that sub-parameter 1120. For example, according to a risk function 1132, $SUBP_1$ 1122 has a maximum risk of 1 for a range of low values, and this risk decreases in inverse proportion $SUBP_1$ as $SUBP_1$ 1122 increases, eventually approaching 0 risk at the highest $SUBP_1$ values.

[0040] Further shown in FIG. 11, the sub-parameter risks 1140 are then weighted 1150 to yield weighted sub-parameter risks 1160, which are summed 1170 to yield the parameter risk $PARA_M$ RISK 1180. In an embodiment, the sub-parameter risk weights 1150 add to a value of 1. Accordingly, the weighted sub-parameter risks 1160

sum to a maximum value of 1, and $PARA_M$ RISK 1180 also varies between 0 to 1 (0% to 100% risk).

[0041] Additionally shown in FIG. 11, the sub-parameter risk calculators 1130 and the sub-parameter risk weights 1150 are dynamically adjustable by SUBP ADJUST controls 1102, which are responsive to controls that originate from the risk analyzer 1300 (FIG. 13). Accordingly, SUBP ADJUST 1102 advantageously responds to discrete realtime data, such as test results, and non-realtime data, such as known disease conditions, family history, genetics and the like. Accordingly, the relative weights 850 for one or more sub-parameter risks 840 are also responsive to SUBP ADJUST controls 722.

[0042] FIG. 12 illustrates a total risk calculation 1200 having parameter risk 1201 inputs and generating a risk 1203 output. In an embodiment, the parameter risks 1201 are assigned parameter risk weights 1210 so that the risk 1201 ranges between 0 to 1. Some parameter risks 1201 are assigned a higher weight to reflect a higher relative contribution of those parameters risks 1201 to the (total) risk 1203 output.

[0043] As shown in FIG. 12, the parameter weights 1210 are advantageously adjustable by RISK ADJUST 1202, which originates from the risk calculation controller 1030 (FIG. 10) and is responsive to controls 1303 (FIG. 13) from the risk analyzer 1300 (FIG. 13). For example, a user can advantageously determine the impact an individual parameter has on risk 1203 over any given time span by utilizing the risk analyzer 1300 (FIG. 13) to assign a zero weight 1210 to that parameter and adjusting other weights 1210 accordingly via controls 1303 (FIG. 13) and RISK ADJUST 1202. As another example, weights 1210 can be adjusted to reflect newly received test data or historical or background information, which indicate that relative parameter risks have changed. As a further example, weights 1210 can be adjusted as described above to reflect a recorded parameter that is active only for a specified time period. As yet another example, some weights 1210 can be zeroed and other weights 1201 adjusted accordingly if one or more parameters are disconnected or otherwise become inactive.

[0044] FIG. 13 illustrates a risk analyzer 1300 that functions in conjunction with a risk processor 1000 (FIG. 10) to re-characterize a medical risk calculation. Risk re-characterization may involve incorporating new or previously unused data into a risk calculation. Such data includes realtime discrete data, such as a lab test that generates a later result; non-realtime discrete data, such as a datum of medical history; and a time segment of previously recorded parameter data, to name a few. Risk re-characterization may also involve recalculating risk excluding one or more previously included parameters so as to allow a user to determine the impact on risk of those parameters.

[0045] As shown in FIG. 13, the risk analyzer 1300 has a record requester 1310 and a risk processor controller 1320. The record requester 1310 is responsive to a data

ID 1301 input so as to generate a record ID 1302 output to the data storage 930 (FIG. 9). The data ID 1301 originates from user I/O 920 (FIG. 9) according to a user selection of previously excluded data, as described with respect to FIG. 9, below. In particular, the record ID 1302 specifies one or more data records 932 (FIG. 9) to retrieve from the data storage 930 (FIG. 9) for the risk processor 1000 (FIG. 9). These records may include parameters and data previously used to calculate risk along with records of heretofore unused parameters and data that the user 50 (FIG. 9) has currently selected, collectively "active" data.

[0046] Also shown in **FIG. 13**, the record requester 1310 communicates this "active" data 1312 to the risk processor controller 1320, which generates controls 1303 to the risk processor 1000 (FIG. 9). These controls 1303 include PARA 1001, RT 1003 and NT 1005 outputs for signaling the risk processor 1000 (FIG. 9) which parameters and discrete data to include in the current calculation of risk. In particular, PARA 1001 specifies which input parameters 912 (FIG. 9) are active. RT 1003 specifies discrete real-time data and NT 1005 specifies non-real-time data to be used in the risk calculations. The risk calculation controller 1030 (FIG. 10) responds to PARA 1001 to generate risk adjust 1034 (FIG. 10), which causes the risk calculation 1200 (FIG. 12) to ignore inactive parameters, as described above. The risk calculation controller 1030 (FIG. 10) also responds to RT 1003 to generate sub-parameter adjust 1032 (FIG. 10), which causes the parameter risk calculator 1000 (FIG. 10) to modify sub-parameter risks 1140 (FIG. 11) to account for real-time discrete data. The risk calculation controller 1030 (FIG. 10) further responds to NRT 1005 to generate sub-parameter adjust 1032 (FIG. 10), which causes the parameter risk calculator 1010 (FIG. 10) to factor in particular subject data, as described above.

[0047] **FIG. 14** illustrates a user input/output (I/O) 1400 that provides user display and control for risk characterization and recharacterization of input parameters and data. The user I/O 1400 has a marker generator 1410 and a user interface 1420. The marker generator 1410 advantageously flags test and result epochs on a user display, as illustrated and described with respect to FIGS. 8A-D, below. In particular, the marker generator 1410 has a parameter record input 1401 from the data store and generates flags 1403 to a display 940 (FIG. 9). The flags 1403 are advantageously used to identify the occurrence of test data and later results relative to a risk record. A user interface 1420 is responsive to user selections 1402 from a user input to select 1402 one or more of these epochs, which may cause the marker generator 1410 to highlight a particular flag or otherwise indicate its selection the display. Further, the user selection 1402 generates a data ID 1404 to the risk analyzer 1300 (FIG. 13), which generates a record ID 1302 (FIG. 13) and controls 1303 (FIG. 13) so as to access the selected data from the data storage and process the data in the risk processor 1000 (FIG. 10) accordingly.

[0048] A medical characterization system has been disclosed in detail in connection with various embodiments. These embodiments are disclosed by way of examples only and are not to limit the scope of the claims that follow. One of ordinary skill in the art will appreciate many variations and modifications.

[0049] The following aspects are preferred embodiments of the invention:

1. A medical characterization system is configured to input medical-related continuous parameters and discrete data so as to calculate a characterization timeline indicative of a physiological condition of a living being, the medical characterization system comprising:

a parameter generator in sensor communications with a living being so as to generate a continuous parameter;

a characterization processor responsive to the continuous parameter so as to generate a medical characterization of the living being as a function of time;

a discrete data source that provides a datum responsive to the living being at a first time and that is available to the characterization processor at a second time; and

a characterization analyzer that enables the characterization processor to update the medical characterization in view of the datum as of the first time.

2. The medical characterization system according to aspect 1 further comprising an analyzer model in communications with the characterization analyzer so as to determine the effect of the medical characterization update over time.

3. The medical characterization system according to aspect 2 wherein the analyzer model comprises a selectable one of an upward shift, a downward aging and an upward ramp.

4. The medical characterization system according to aspect 3 further comprising a data storage in communications with the data source and the characterization processor so that the characterization analyzer can selectively update past portions of the medical characterization with later data.

5. The medical characterization system according to aspect 4 further comprising an input/output interface that allows a person to selectively control the medical characterization updates.

6. The medical characterization system according to aspect 5 wherein the input/output interface comprises a display navigation tool that displays a selectable

test epoch at the first time and a corresponding result epoch at the second time.

7. The medical characterization system according to aspect 6 wherein the analyzer model is responsive to one of a therapy time epoch and a test time epoch in view of a result epoch. 5

8. A medical characterization method comprising: 10

generating a plurality of parameters responsive to sensors in communication with a person; calculating a medical characterization from the parameters that is generally indicative of the physiological condition of the person; performing a medical test on the person at a test time; receiving the medical test result at a later result time; and updating the medical characterization according to the medical test result as of the test time. 15 20

9. The medical characterization method according to aspect 8 further comprising modeling the behavior of the medical characterization over time in response to the medical test as a test model. 25

10. The medical characterization method according to aspect 9 further comprising: 30

displaying the medical characterization as a function of time; indicating the test time on the display as a test epoch; and indicating the result time on the display as a result epoch. 35

11. The medical characterization method according to aspect 10 further comprising selecting at least one of the test epoch and the result epoch so as to initiate the updating. 40

12. The medical characterization method according to aspect 11 further comprising applying the test model to the medical characterization as of the test time in response to the selecting. 45

13. The medical characterization method according to aspect 11 further comprising indicating a therapy time on the display as a therapy epoch. 50

14. The medical characterization method according to aspect 13 further comprising: 55

modeling the behavior of the medical characterization over time in response to a therapy as a therapy effectiveness model; indicating a therapy time on the display as a ther-

apy epoch; selecting the therapy epoch; and applying the therapy effectiveness model to the medical characterization as of the therapy time in response to selecting the therapy epoch.

15. A medical characterization apparatus comprising: 10

a data source that provides both a continuous parameter timeline and a discrete test result responsive to the medical state of a living being at a test time; a characterization processor in communications with the data source so as to calculate a medical characterization of the living being according to each of the continuous parameter and the discrete test result; and a characterization analyzer that updates the continuous parameter timeline according to the discrete test result as of the test time. 15 20

16. The medical characterization apparatus according to aspect 15 wherein the characterization processor comprises: 25

an input selector that allows a user to select a current data input or a sync data input as a medical data output; a processor engine that inputs the medical data and generates a medical characterization; and a processor model that determines how the medical characterization is calculated based upon the medical data. 30 35

17. The medical characterization apparatus according to aspect 16 wherein the characterization analyzer comprises an analyzer engine that combines current medical data and recalled medical data to generate sync data according to an analyzer model. 40

18. The medical characterization apparatus according to aspect 17 further comprising: 45

a graphics generator that outputs the medical characterization to a display; and a marker generator that indicates test and result epochs on the display in conjunction with the medical characterization. 50

19. The medical characterization apparatus according to aspect 18 further comprising an analyzer model that determines the effect of a test result on the medical characterization. 55

20. The medical characterization apparatus according to aspect 19 wherein the analyzer model further indicates the effectiveness of an earlier therapy 60

based upon the test result.

Claims

1. A system for deriving a risk characterization parameter for a patient, the system comprising one or more hardware processors configured to:

receive optical data from an optical sensor;
determine a plurality of parameters based on the received optical data, wherein at least one of the plurality of parameters comprise oxygen saturation;
extract a plurality of subparameters corresponding to the oxygen saturation, wherein the subparameters comprise saturation baseline, saturation instability, and saturation average slope;
apply a respective risk function to each of the plurality of subparameters;
calculate a plurality of subparameter risk values based on the application of respective risk functions;
calculate an oxygen saturation risk based on an application of a plurality of weights to the calculated plurality of subparameter risk values;
generate a total risk parameter based on the calculated oxygen saturation risk and risks associated with rest of the plurality of parameters; and
display the total risk parameter.

2. The system of Claim 1, wherein the one or more hardware processors are further configured to allow a user to dynamically include or exclude the plurality of parameters from calculation of the total risk parameter and update the total risk parameter based on the user selection.

3. The system of Claim 1, wherein the one or more hardware processors are further configured to modify the total risk parameter based on non-real-time data.

4. The system of Claim 1, wherein the plurality of weights are automatically selected based on active data.

5. The system of Claim 1, wherein the plurality of weights are automatically selected based on user defined criteria.

6. The system of Claim 1, wherein the one or more hardware processors are further configured to display a historical trend of the total risk parameter.

7. The system of Claim 1, wherein the one or more hardware processors are further configured to display a plurality of markers.

8. A method of calculating an oxygen saturation risk parameter, the method comprising:

5 receiving optical data from an optical sensor;
determining a plurality of parameters based on the received optical data, wherein at least one of the plurality of parameters comprise oxygen saturation;
10 extracting a plurality of subparameters corresponding to the oxygen saturation, wherein the subparameters comprise saturation baseline, saturation instability, and saturation average slope;
15 applying a respective risk function to each of the plurality of subparameters;
calculating a plurality of subparameter risk values based on the application of respective risk functions; and
20 calculating the oxygen saturation risk parameter based on an application of a plurality of weights to the calculated plurality of subparameter risk values.

9. The method of Claim 8, further comprising allowing a user to dynamically include or exclude the plurality of parameters from calculation of the oxygen saturation risk parameter and updating the oxygen saturation risk parameter based on the user selection.

10. The method of Claim 8, further comprising modifying the oxygen saturation risk parameter based on non-real-time data.

11. The method of Claim 8, wherein the plurality of weights are automatically selected based on active data.

12. The method of Claim 8 wherein the plurality of weights are automatically selected based on user defined criteria.

13. The method of Claim 8, wherein the plurality of parameters comprise real-time and non-real-time parameters.

14. A computer program product comprising instructions which, when the program is executed by a computer, cause the computer to carry out the steps of the method according to any of claims 8-13.

15. A computer-implemented method according to any of claims 8-13.

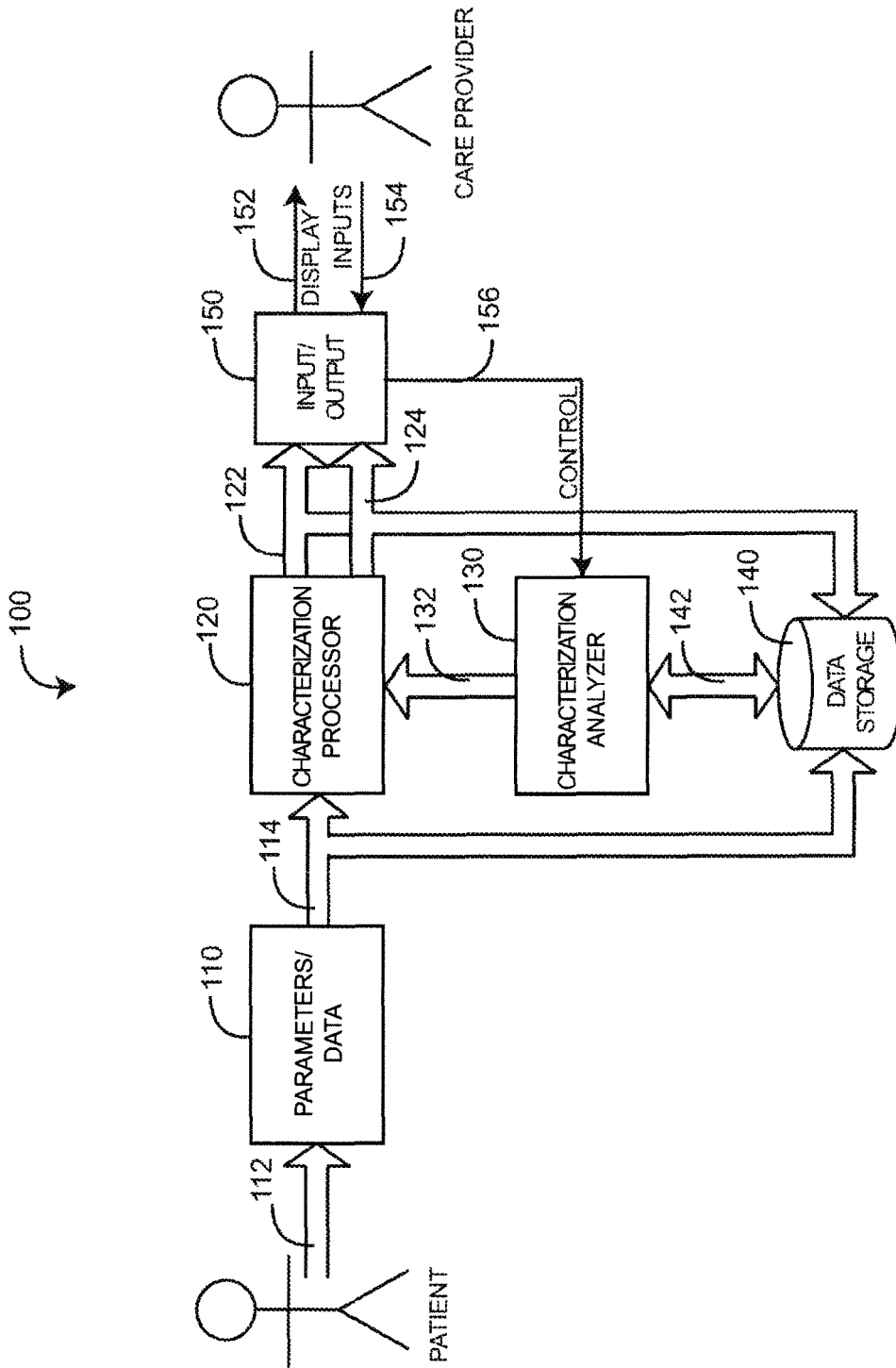

FIG. 1

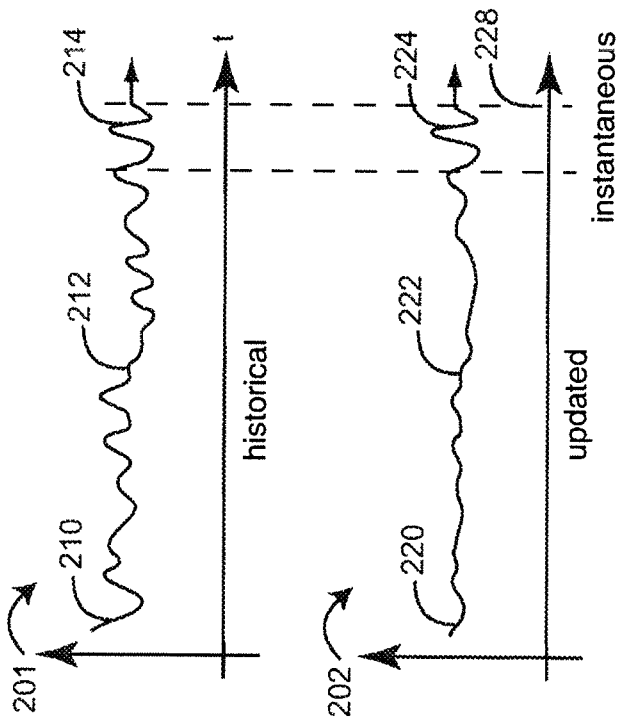

FIG. 2A

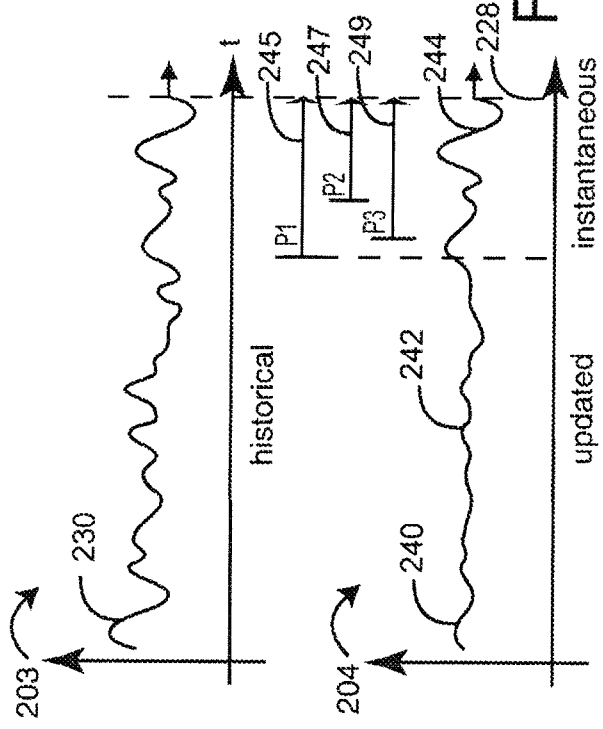

FIG. 2B

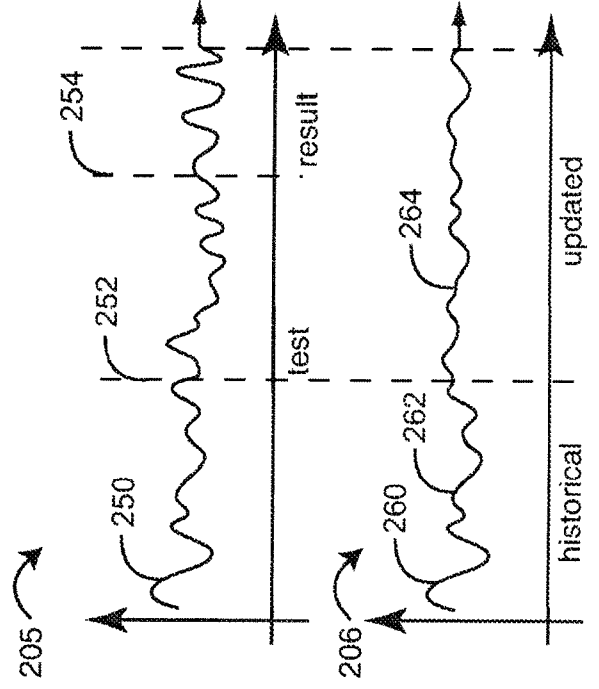

FIG. 2C

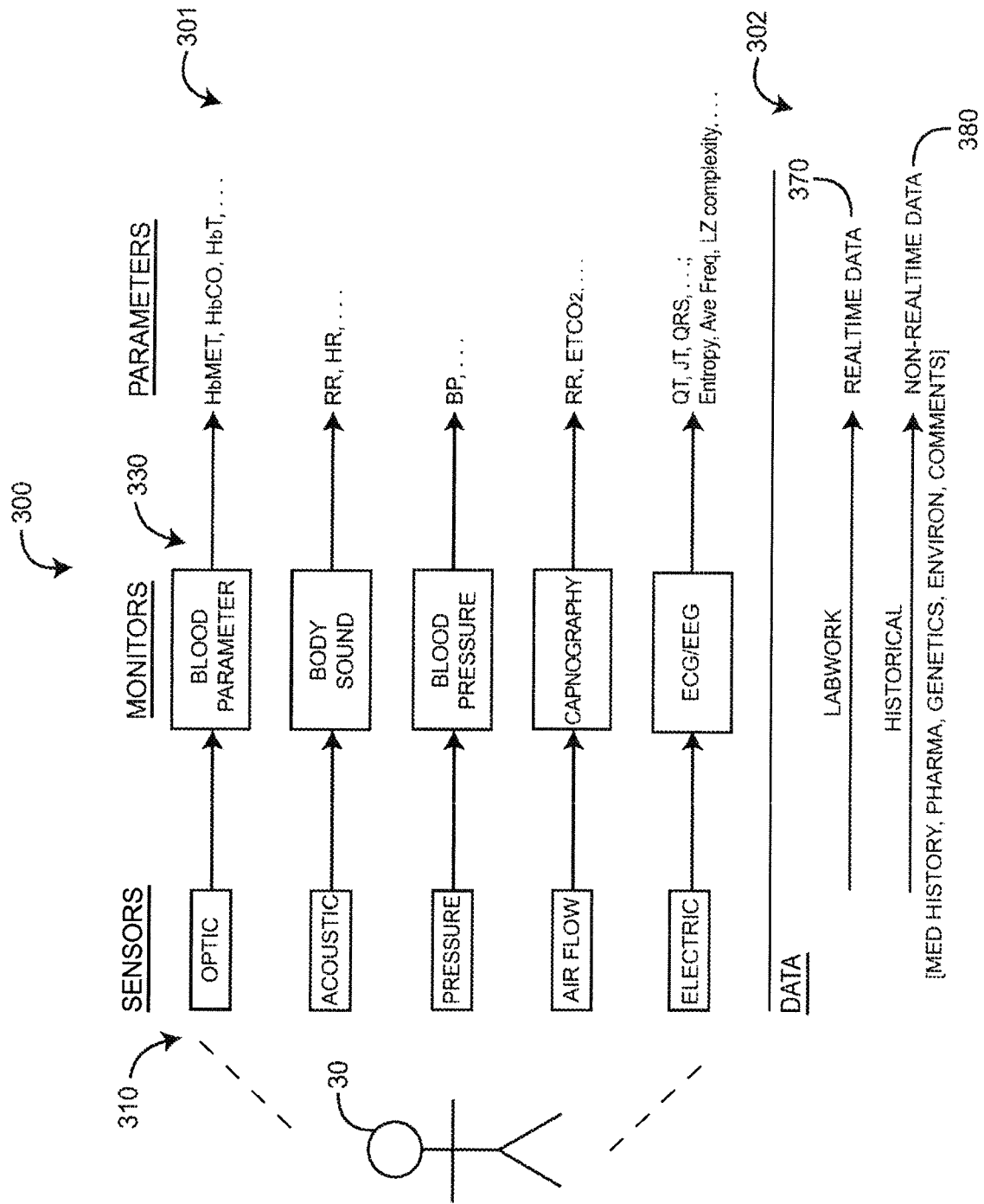

FIG. 3

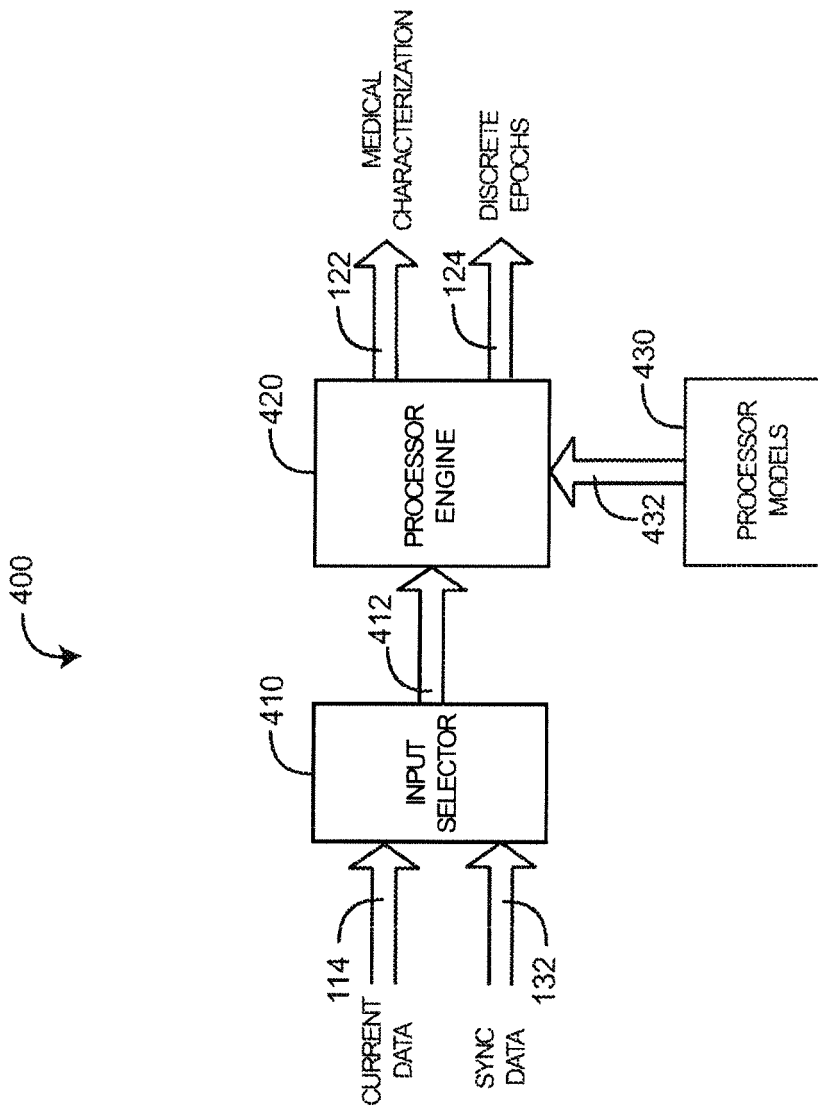

FIG. 4

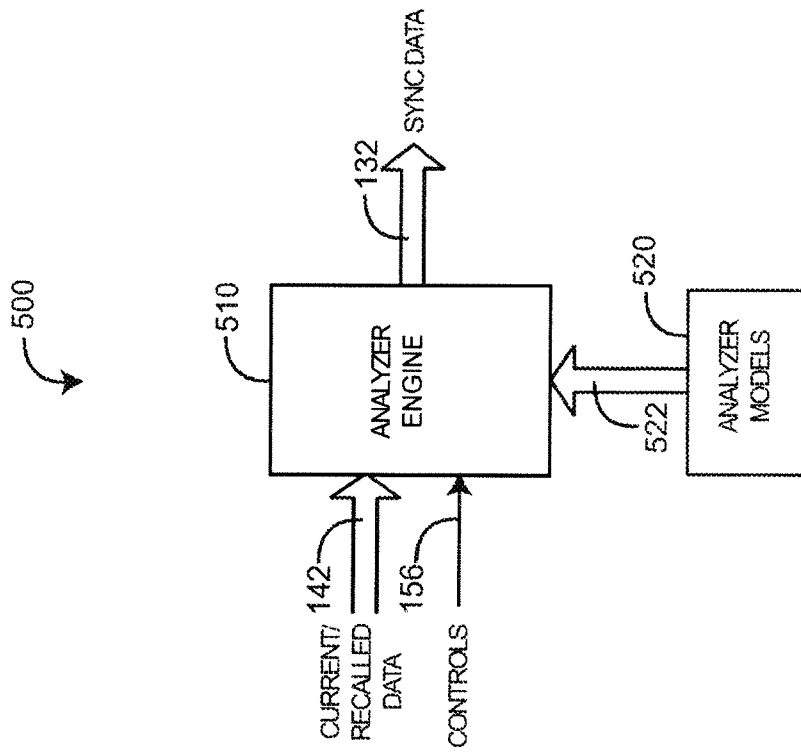

FIG. 5

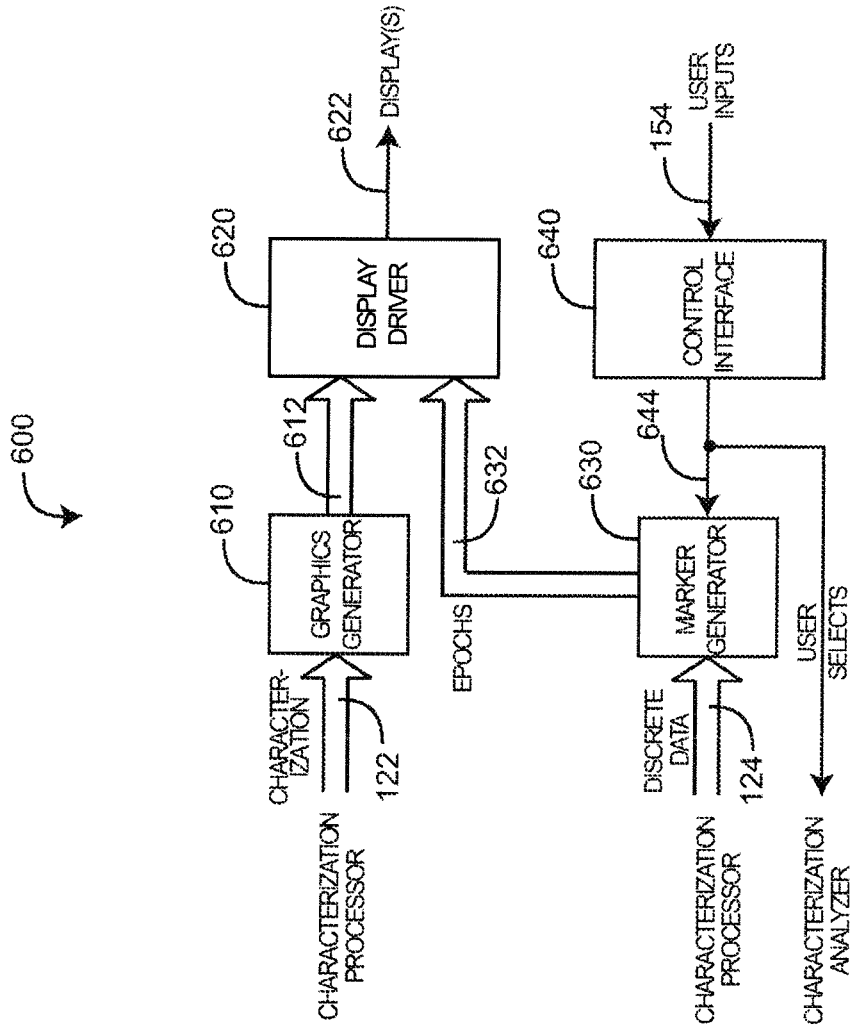

FIG. 6

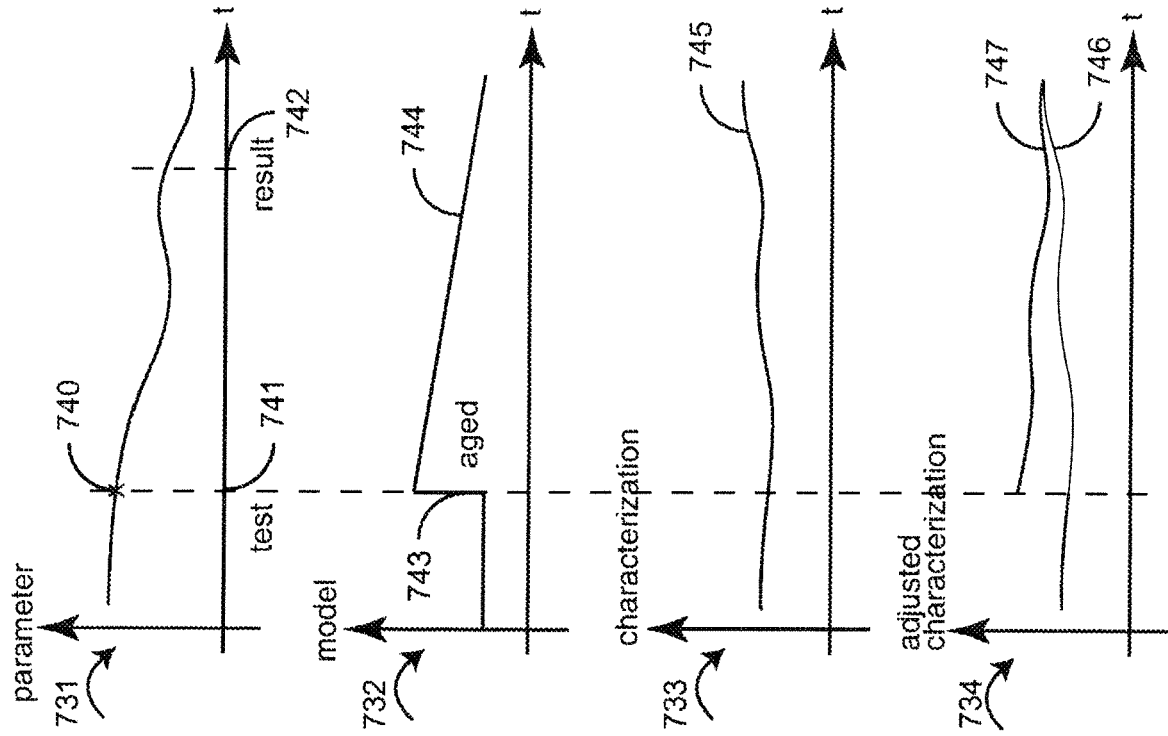
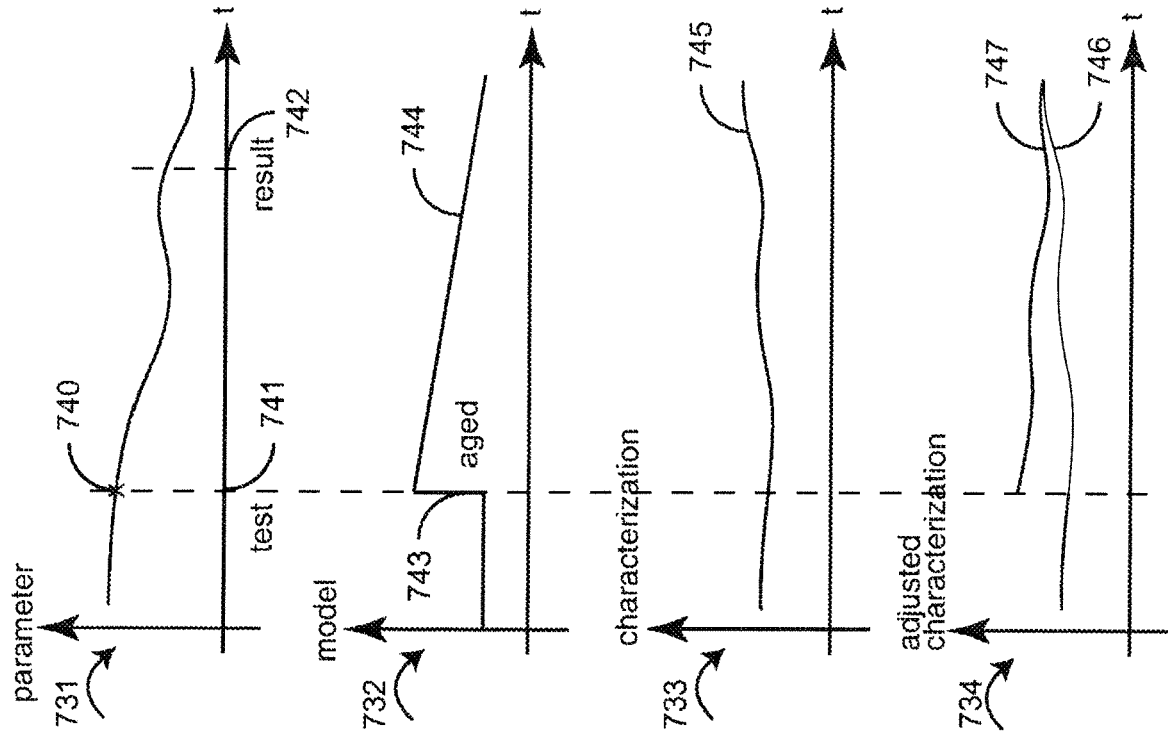
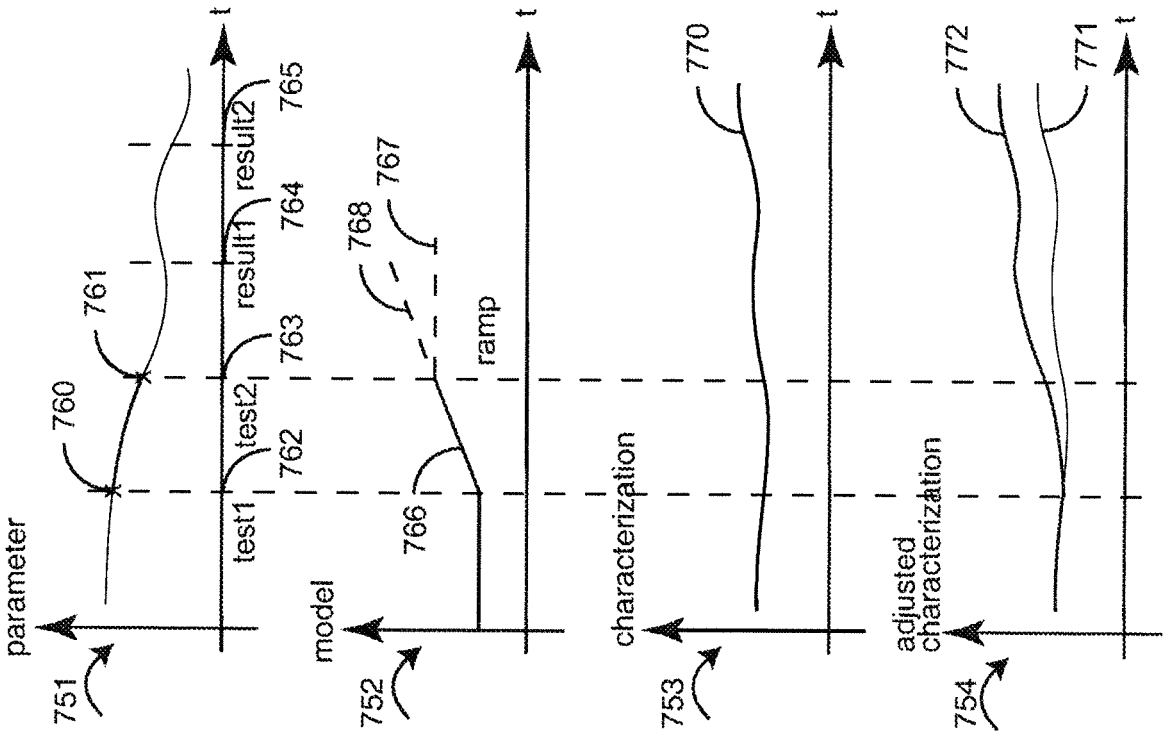
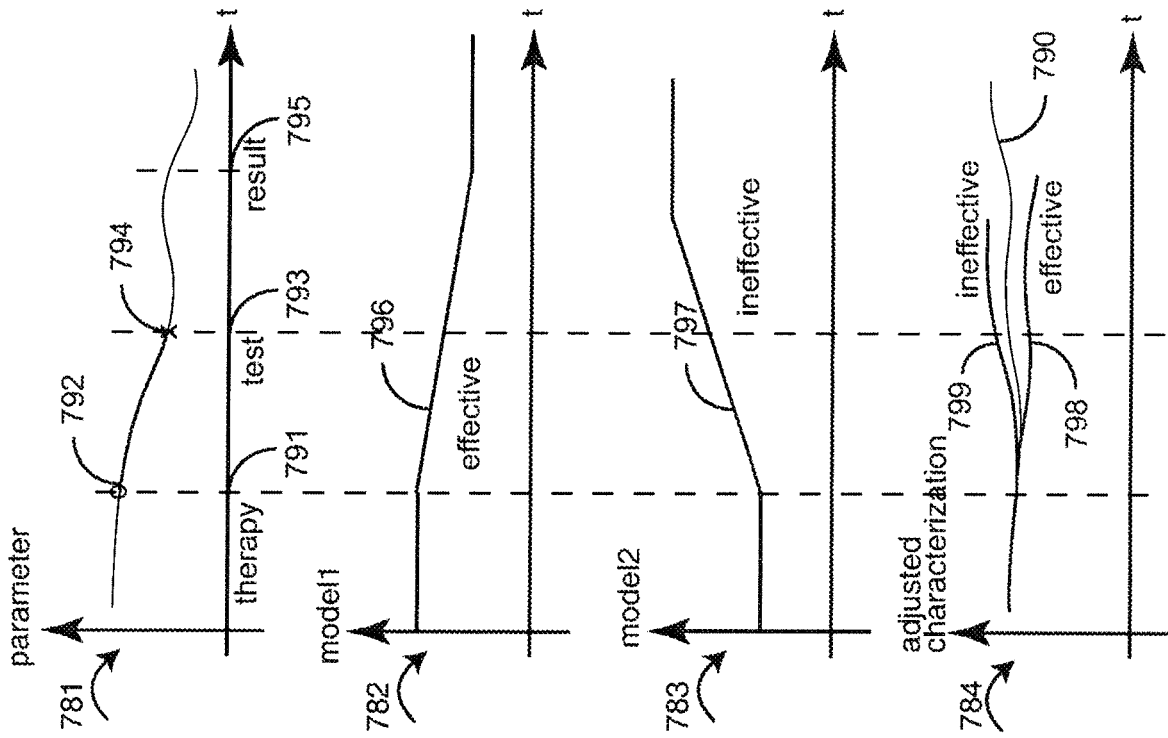

FIG. 7B

FIG. 7A



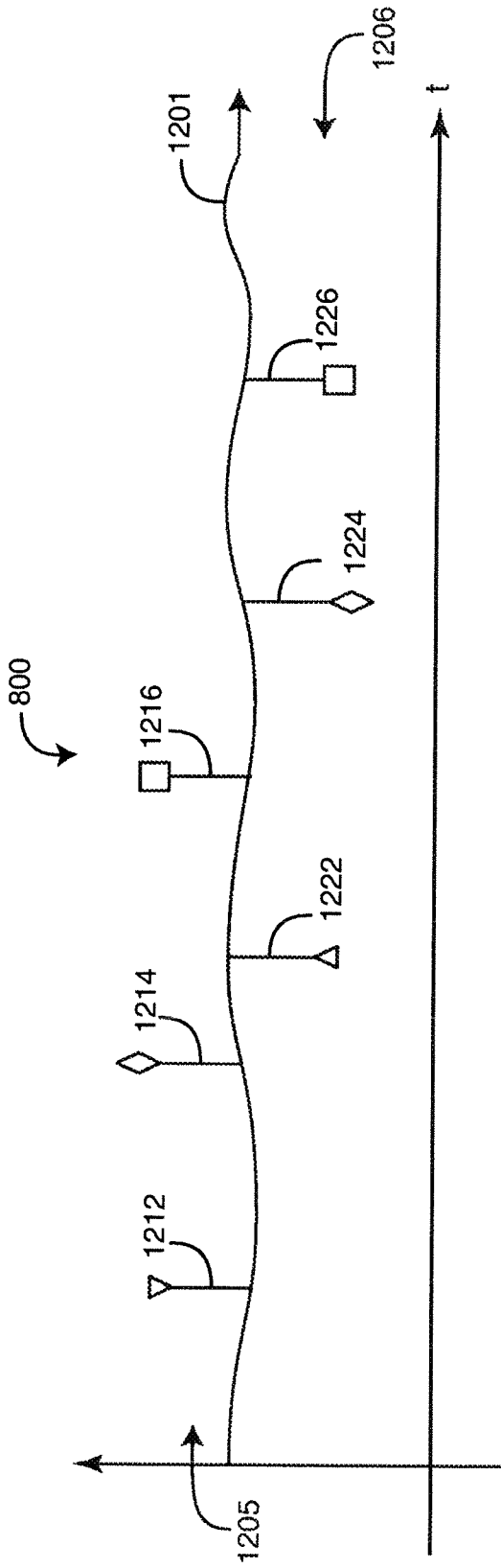

FIG. 8A

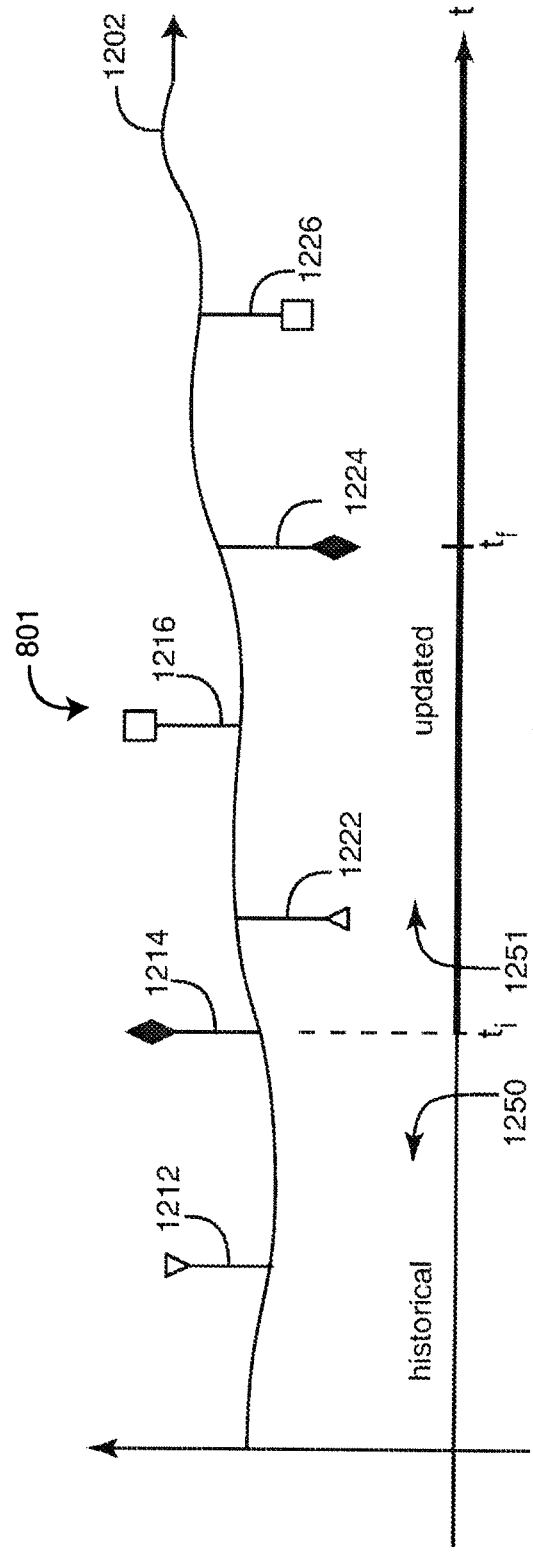

FIG. 8B

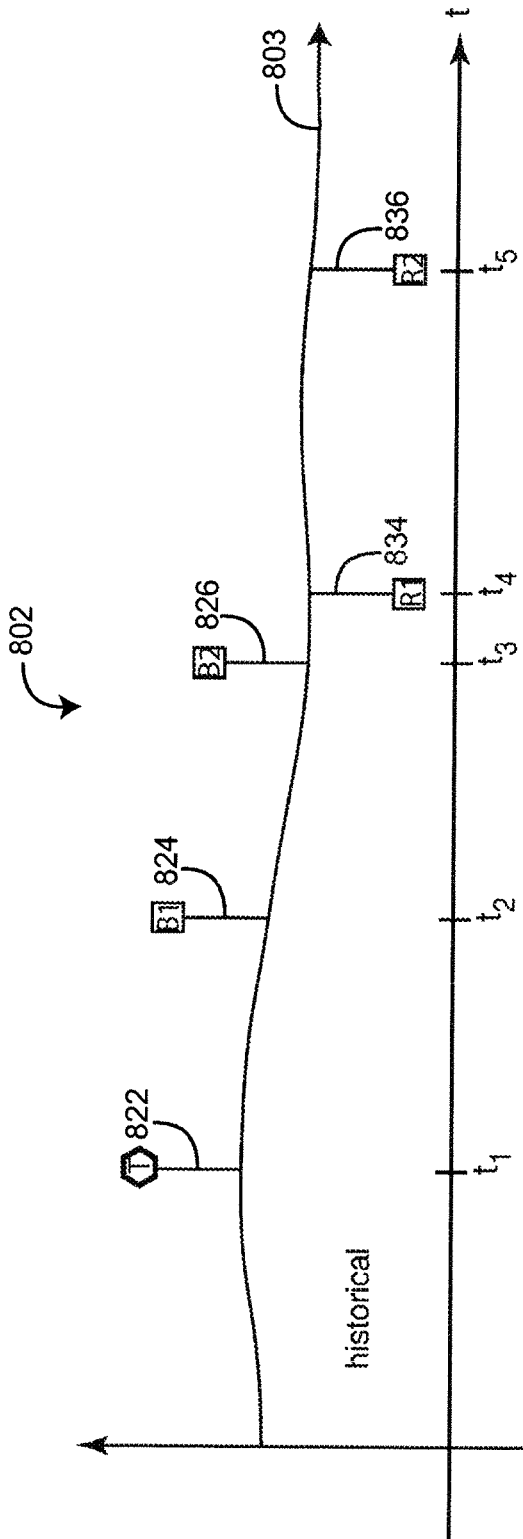

FIG. 8C

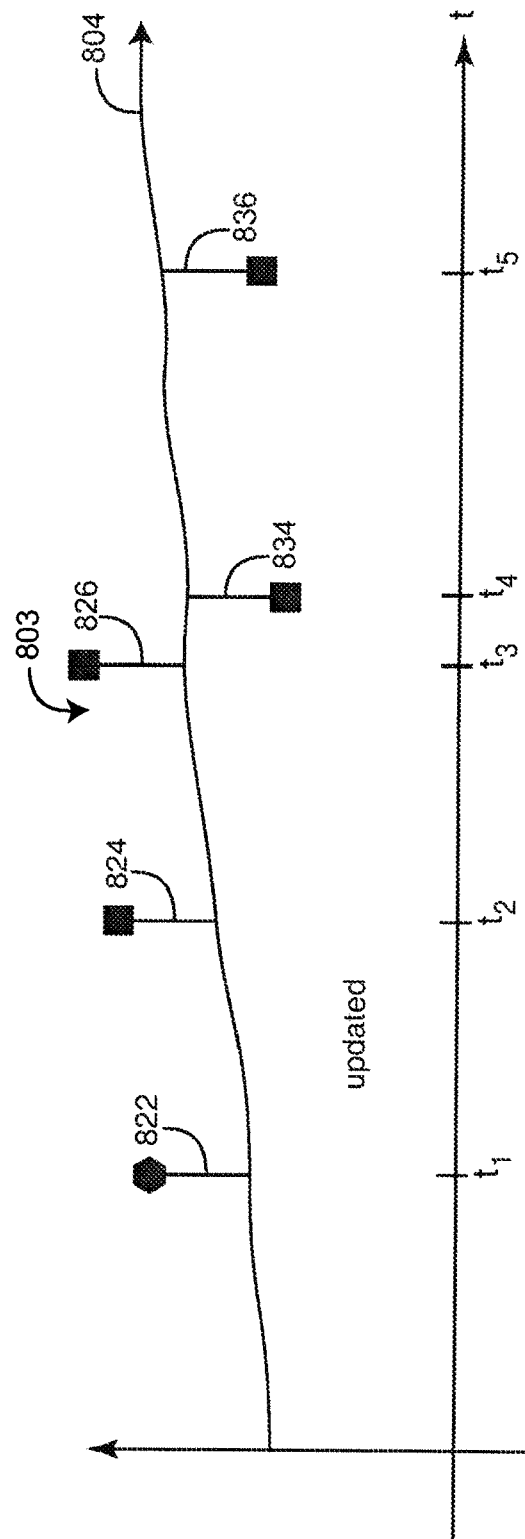

FIG. 8D

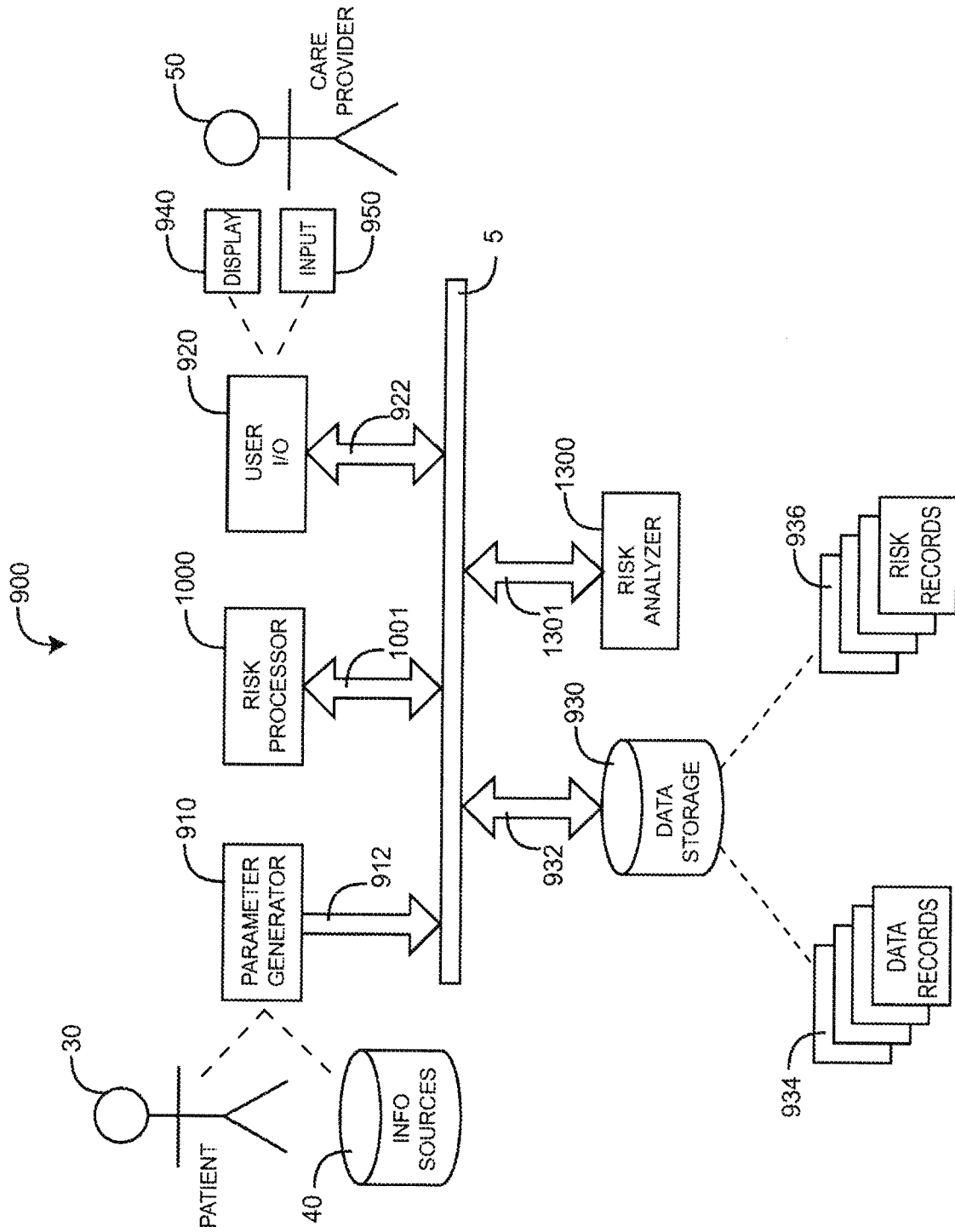

FIG. 9

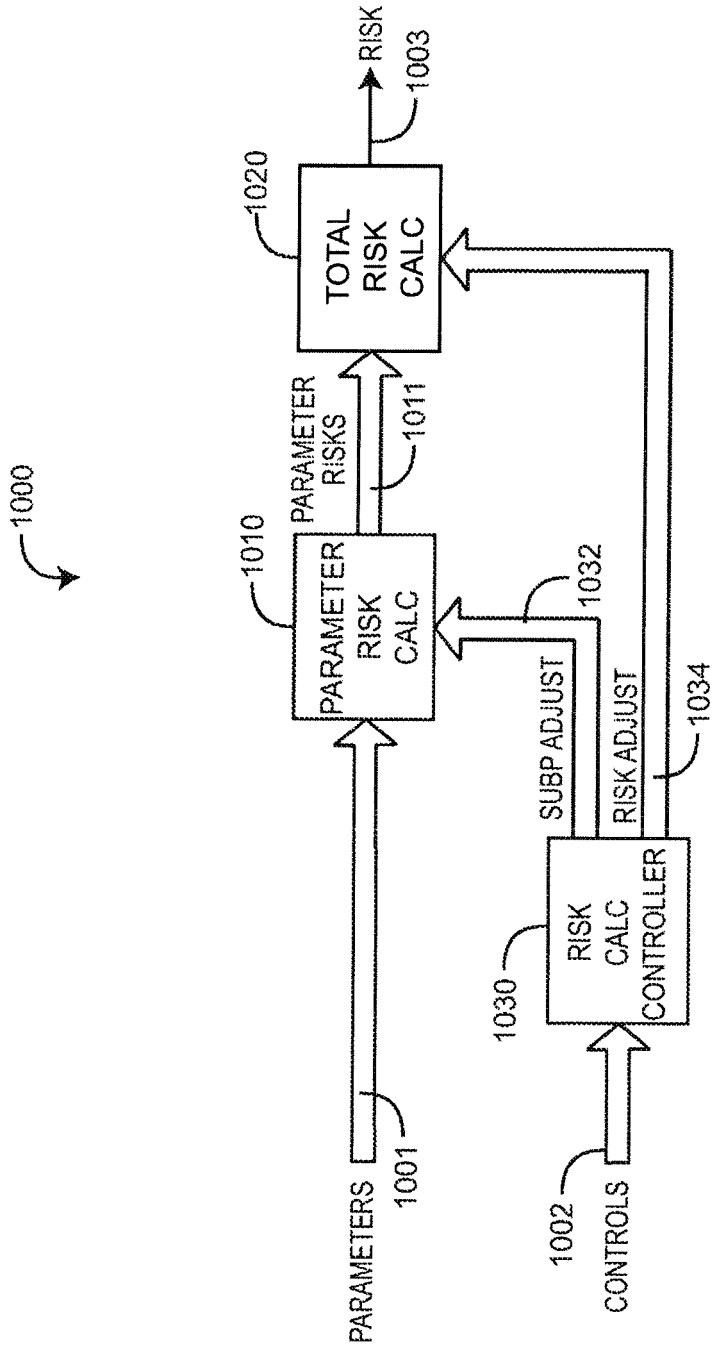

FIG. 10

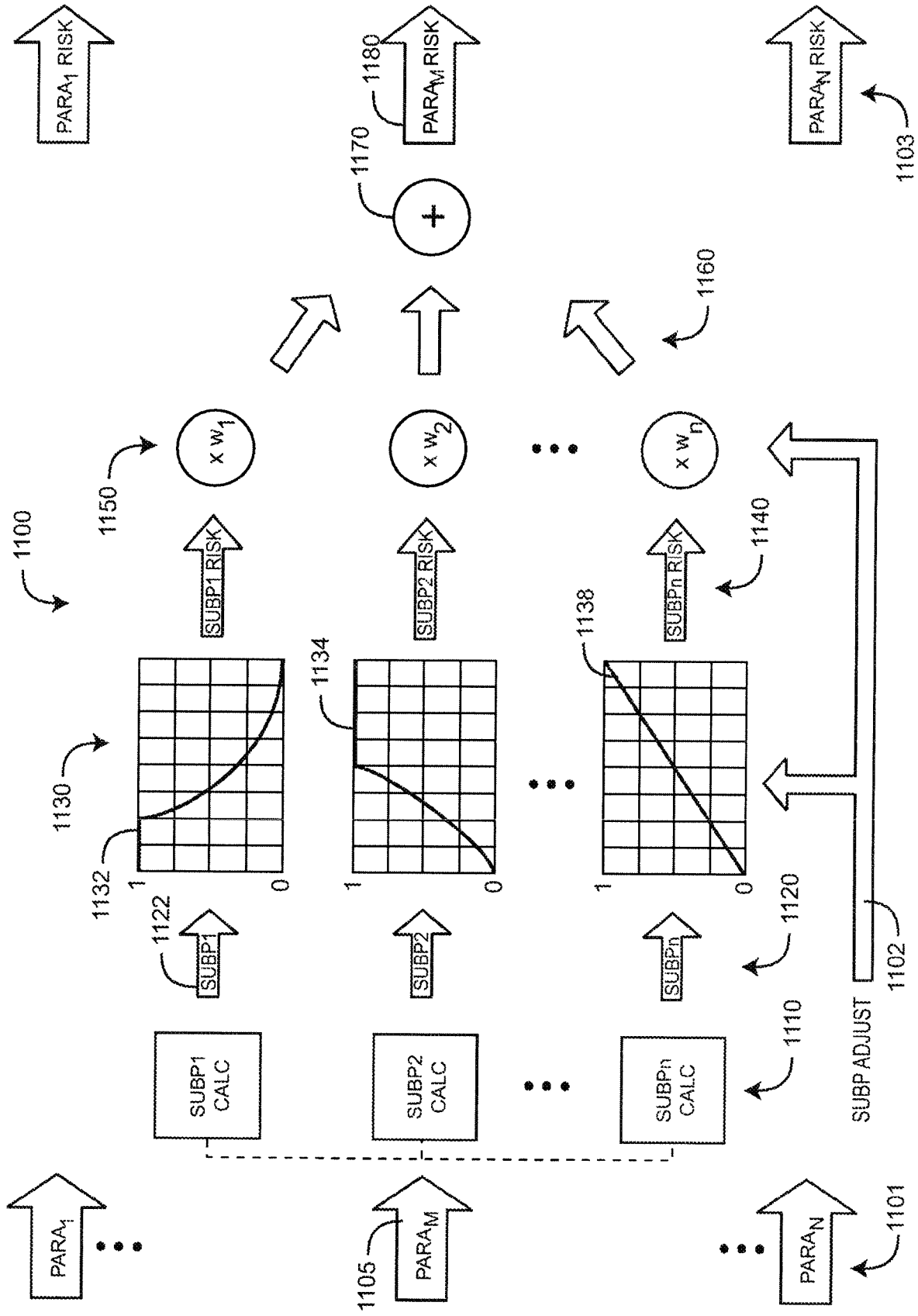

FIG. 11

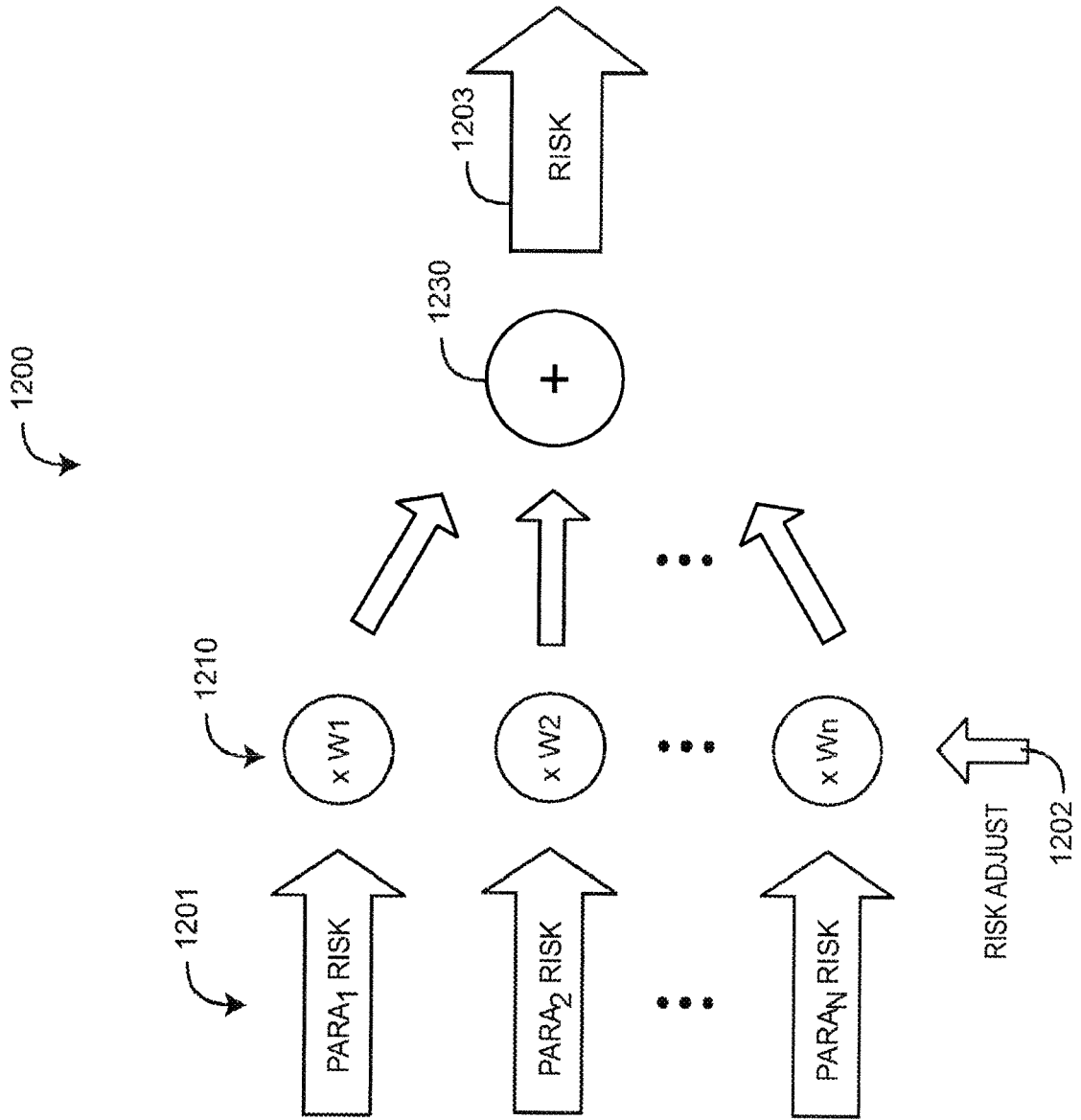

FIG. 12

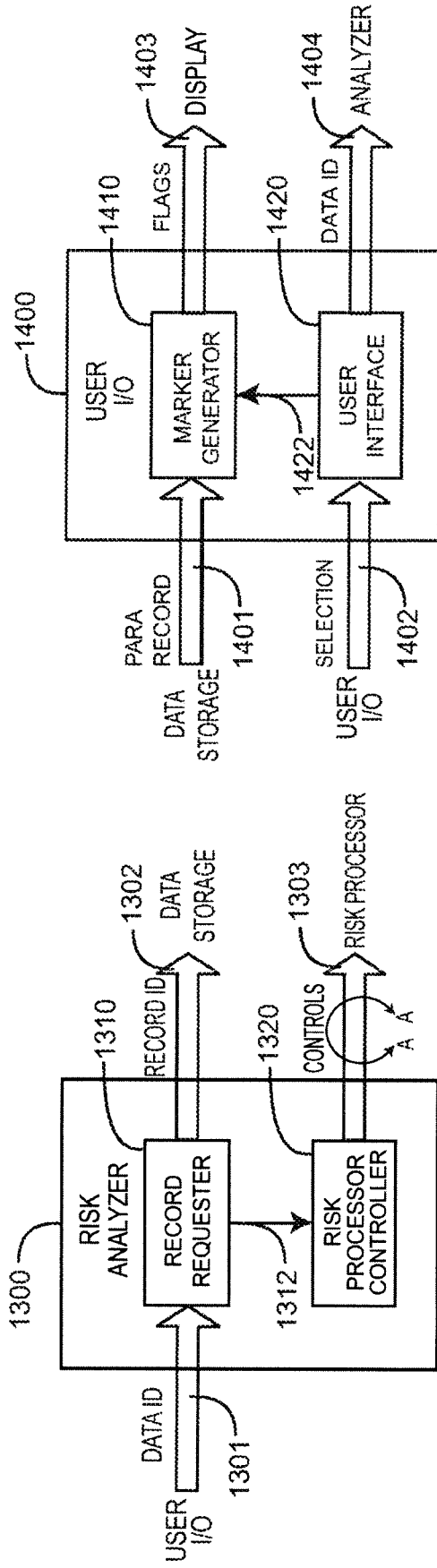
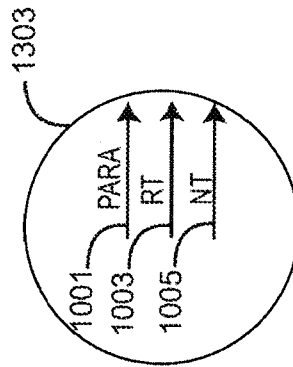

FIG. 13

FIG. 14



DETAIL A-A



EUROPEAN SEARCH REPORT

Application Number
EP 19 16 1258

5

10

15

20

25

30

35

40

45

50

55

DOCUMENTS CONSIDERED TO BE RELEVANT			
Category	Citation of document with indication, where appropriate, of relevant passages	Relevant to claim	CLASSIFICATION OF THE APPLICATION (IPC)
X	DANIELE APILETTI ET AL: "SAPhyRA: Stream Analysis for Physiological Risk Assessment", COMPUTER-BASED MEDICAL SYSTEMS, 2007. CBMS '07. TWENTIETH IEEE INTERNATIONAL SYMPOSIUM ON, IEEE, PI, 26 June 2007 (2007-06-26), pages 193-198, XP031184737, ISBN: 978-0-7695-2905-9 * The whole document, in particular: Sections 1 - 3 on pages 1 - 4. *	1-15	INV. G16H50/30 G16H50/20 A61B5/00 ADD. A61B5/0432 A61B5/087 A61B5/1455
X	JP 2009 066269 A (TAKADA YOSHIFUMI; ASANO TAKEHIRO; TEIJIN PHARMA LTD) 2 April 2009 (2009-04-02) * The whole document, in particular: Paragraphs [0001], [0021], [0023], [0027]. *	1-15	
X	US 2001/018557 A1 (LYNN LAWRENCE A [US] ET AL) 30 August 2001 (2001-08-30) * The whole document, in particular: Paragraphs [0010] - [0013], [0024], [0025]. *	1-15	TECHNICAL FIELDS SEARCHED (IPC) G16H A61B
The present search report has been drawn up for all claims			
Place of search Munich		Date of completion of the search 2 October 2019	Examiner Nagele, Stefan
CATEGORY OF CITED DOCUMENTS X : particularly relevant if taken alone Y : particularly relevant if combined with another document of the same category A : technological background O : non-written disclosure P : intermediate document		T : theory or principle underlying the invention E : earlier patent document, but published on, or after the filing date D : document cited in the application L : document cited for other reasons & : member of the same patent family, corresponding document	

EPO FORM 1503 03/02 (P04/C01)

**ANNEX TO THE EUROPEAN SEARCH REPORT
ON EUROPEAN PATENT APPLICATION NO.**

EP 19 16 1258

5

This annex lists the patent family members relating to the patent documents cited in the above-mentioned European search report. The members are as contained in the European Patent Office EDP file on The European Patent Office is in no way liable for these particulars which are merely given for the purpose of information.

02-10-2019

10

Patent document cited in search report	Publication date	Patent family member(s)	Publication date
JP 2009066269 A	02-04-2009	JP 5178106 B2 JP 2009066269 A	10-04-2013 02-04-2009
US 2001018557 A1	30-08-2001	US 6223064 B1 US 2001018557 A1 US 2002173707 A1	24-04-2001 30-08-2001 21-11-2002

15

20

25

30

35

40

45

50

55

EPO FORM P0459

For more details about this annex : see Official Journal of the European Patent Office, No. 12/82

REFERENCES CITED IN THE DESCRIPTION

This list of references cited by the applicant is for the reader's convenience only. It does not form part of the European patent document. Even though great care has been taken in compiling the references, errors or omissions cannot be excluded and the EPO disclaims all liability in this regard.

Patent documents cited in the description

- US 61442264 A [0001]
- US 00950511 A [0035]
- US 26929611 A [0035]

专利名称(译)	医疗风险鉴定系统		
公开(公告)号	EP3567603A1	公开(公告)日	2019-11-13
申请号	EP2019161258	申请日	2012-02-13
[标]申请(专利权)人(译)	梅西莫股份有限公司		
申请(专利权)人(译)	Masimo公司		
当前申请(专利权)人(译)	Masimo公司		
[标]发明人	AL ALI AMMAR		
发明人	AL-ALI, AMMAR		
IPC分类号	G16H50/30 G16H50/20 A61B5/00 A61B5/0432 A61B5/087 A61B5/1455		
CPC分类号	A61B5/0432 A61B5/087 A61B5/14551 A61B5/7275 G16H50/20 G16H50/30 A61B5/02055 A61B5/022		
审查员(译)	NAGELE , STEFAN		
优先权	61/442264 2011-02-13 US PCT/US2012/024908 2012-02-13 WO		
外部链接	Espacenet		

摘要(译)

医学表征系统被配置为输入医学相关的连续参数和离散数据，以便计算指示生物的生理状况的表征时间线。数据源与患者进行传感器通信以生成连续参数。数据源还提供在测试时间响应患者的测试数据。结果，测试数据可用于表征处理器。表征处理器还响应于连续参数，以产生作为时间的函数的医学表征。表征分析器使表征处理器能够根据截至测试时间的测试数据来更新医学表征。

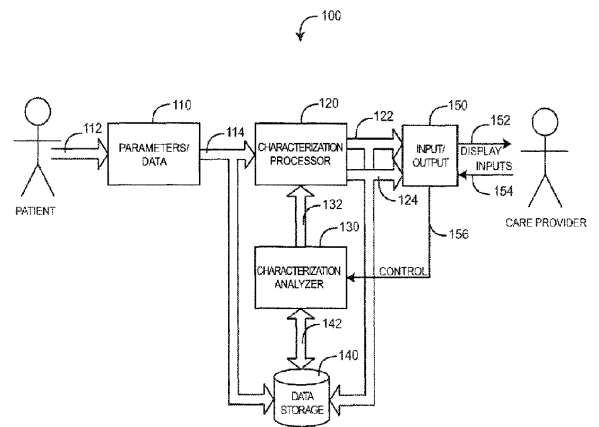

FIG. 1