

(19)



(11)

**EP 1 596 705 B1**

(12)

**EUROPEAN PATENT SPECIFICATION**

(45) Date of publication and mention of the grant of the patent:  
**12.09.2018 Bulletin 2018/37**

(51) Int Cl.:  
**A61B 18/04<sup>(2006.01)</sup> A61B 18/14<sup>(2006.01)</sup>**

(21) Application number: **04708664.0**

(86) International application number:  
**PCT/US2004/003614**

(22) Date of filing: **05.02.2004**

(87) International publication number:  
**WO 2004/071278 (26.08.2004 Gazette 2004/35)**

**(54) TEMPERATURE INDICATING ELECTROSURGICAL APPARATUS**

ELEKTROCHIRURGISCHE VORRICHTUNG FÜR TEMPERATURANZEIGE

APPAREIL ELECTROCHIRURGICAL D'INDICATION THERMIQUE

(84) Designated Contracting States:  
**AT BE BG CH CY CZ DE DK EE ES FI FR GB GR HU IE IT LI LU MC NL PT RO SE SI SK TR**

• **PACEK, James, L.**  
**Coto De Caza, CA 92679 (US)**

(30) Priority: **05.02.2003 US 445405 P**

(74) Representative: **Warren, Caroline Elisabeth et al**  
**Mathys & Squire LLP**  
**The Shard**  
**32 London Bridge Street**  
**London SE1 9SG (GB)**

(43) Date of publication of application:  
**23.11.2005 Bulletin 2005/47**

(73) Proprietor: **ARTHROCARE CORPORATION**  
**Austin, TX 78735 (US)**

(56) References cited:  
**WO-A1-00/62685 WO-A1-99/17690**  
**GB-A- 2 333 455 US-A- 3 633 425**  
**US-A- 3 633 425 US-A- 4 509 532**  
**US-A- 5 599 350 US-A- 6 004 319**  
**US-A- 6 047 700 US-A1- 2001 001 314**  
**US-A1- 2001 056 280 US-A1- 2002 107 516**  
**US-A1- 2003 013 986 US-A1- 2003 220 637**  
**US-B1- 6 174 309 US-B1- 6 174 309**  
**US-B1- 6 514 250**

(72) Inventors:  
• **WOLOSZKO, Jean**  
**Mountain View, CA 94040 (US)**  
• **DAHLA, Robert, H.**  
**Sunnyvale, CA 94087 (US)**  
• **BAKER, Michael, A.**  
**Woodside, CA 94062 (US)**

**EP 1 596 705 B1**

Note: Within nine months of the publication of the mention of the grant of the European patent in the European Patent Bulletin, any person may give notice to the European Patent Office of opposition to that patent, in accordance with the Implementing Regulations. Notice of opposition shall not be deemed to have been filed until the opposition fee has been paid. (Art. 99(1) European Patent Convention).

## Description

### BACKGROUND OF THE INVENTION

**[0001]** The present invention relates generally to the field of electrosurgical devices, and more particularly to devices allowing for the monitoring of temperature in regions adjacent, in contact with, and/or surrounding a working end of such electrosurgical devices.

**[0002]** Electrosurgical procedures are extremely common in today's medical practice. For example, present uses of electrosurgical devices include ablation, dissection, resection, coagulation, contraction, or otherwise modification of a broad range of tissues and organs. Thus, general surgery, cosmetic surgery, neurosurgery, laparoscopy, as well as arthroscopic procedures, etc., routinely employ electrosurgical devices and techniques. However, unintended and excessive heating of non-target tissue during the procedure is a common concern in most electrosurgical applications. Such unintended heating of non-target tissue may cause inadvertent necrosis or other damage. Naturally, a medical practitioner employing such devices has a need to know the temperature of the region adjacent to, surrounding, and/or in contact with the working end of the device

**[0003]** Most electrosurgical cutting devices operate by applying electrical energy to affect tissue. In a first mode, electrical current flows through tissue and as a result of a high current density at the working end of the electrosurgical device (e.g., an electrode), an electrical arc forms across a gap between the electrode and the target tissue. The arc results in rapid tissue heating and vaporization of cellular fluids into steam. In another mode, electrical energy may be directly conducted through tissue, but instead of forming an arc, the resistive properties of the tissue result in heating of the tissue to produce a thermal effect. In yet another mode, as developed by ArthroCare Corporation, Sunnyvale CA, RF energy is applied to a conductive medium (usually saline), causing a highly focused plasma field to form around the electrodes. This plasma field is comprised of highly ionized particles which have sufficient energy to break organic molecular bonds within tissue. The by-products of this non-heat driven process are elementary molecules and low molecular weight gases. This latter mode is a non-heat driven (the ablation is achieved via the ionized particles) low temperature (surface tissue temperatures 40-70°C) ablative process and is termed Coblation®. The Coblation® process is discussed more thoroughly below.

**[0004]** In all of the modes described above, a certain amount of heat is generated in the tissue as either a by-product or as a direct result of the mode. This heat conducts through tissue. In the modes which rely on passing electrical current through tissue, electrical current as well as heat conduct through tissue. As a result, heating often occurs not only in or near the target tissue but also in regions surrounding the target tissue. Accordingly, such heating of the surrounding tissue may result in undesir-

able collateral tissue damage.

**[0005]** Another problem may be found as some surgical procedures require a "wet" field, (*i.e.*, the surgical site is immersed in a fluid medium.) Heat generated by the electrosurgical procedure may accumulate in the fluid medium through transfer of heat into the fluid. In those cases where the fluid medium is a electrically conductive, shorting of the electrode(s) may also occur and result in additional unintended heating in the treatment area. Ultimately, too much additional heating may result in excessive collateral tissue damage.

**[0006]** A number of electrosurgical devices are known that include temperature sensors for sensing temperature in or around a surgical site during a procedure. Such devices typically use electrical temperature sensors, such as thermistors, thermocouples, resistance temperature detectors (RTDs), or fiber optic-based temperature sensors (*e.g.*, US Patent Nos. 6,293,943 and 6,197,021, both to Panescu et al.).

**[0007]** However, during the procedures described above, a medical practitioner's attention is mainly focused on the operative field either through a viewing monitor (*e.g.*, during a less invasive procedure) or direct visualization (*e.g.*, an open surgical procedure.) Accordingly, there remains a need remains for the medical practitioner to be able to identify the temperature in regions adjacent to, in contact with, and/or surrounding a working end of a electrosurgical devices without solely having to remove his or her attention from the operative field. There also remains a need to provide such a medical device that is disposable and compatible with existing controllers or power supplies.

**[0008]** US Patent US5,599,350 describes an electrosurgical haemostatic instrument in which the coagulation status of tissue engaged by two elements delivering electrosurgical energy to tissue may be observed, and in which damage from thermal spread may be minimised.

**[0009]** US6,174,309 describes an electrosurgical instrument which has a handle and a body which positions and closes a jaw about a tissue site for simultaneously cutting and sealing relatively large tissue structures.

**[0010]** US6,514,250 describes a suction-assisted ablation device having a support surface, suction elements disposed adjacent the support surface, at least one electrode and at least one suction conduit. The device may further include fluid openings, which allow fluid to irrigate target tissue and aid in ablation.

**[0011]** United Kingdom Patent Application Publication No. GB2333455 describes an electrosurgical assembly, which may be used for surgical diathermy and includes looped wired soldered to a conductive sheet backed by an insulating sheet. The conductive sheet is coated with temperature indicating paint or material of known infrared emissivity so as to give an indication of the temperature of tissue into which the wires are WO0062685, US2002/0107516 and WO99/17690 also disclose devices similar to the present invention.

## SUMMARY OF THE INVENTION

**[0012]** Aspects and examples of the invention are set out in the claims. Systems, devices, and methods for the monitoring of temperature in regions adjacent, in contact with, and/or surrounding an electrosurgical device are described herein.

## BRIEF DESCRIPTION OF THE DRAWINGS

**[0013]**

Fig. 1 illustrates a system including an electrosurgical probe, the probe having a temperature indicating element according to one arrangement not according to the invention.

Fig. 2A illustrates an electrosurgical probe having a temperature-indicating element according to another arrangement not according to the invention.

Fig. 2B illustrates an electrosurgical probe having a temperature-indicating element according to another arrangement not according to the invention.

Fig. 3 shows a system incorporating an electrosurgical catheter, the catheter including a temperature-indicating element, according to another arrangement not according to the invention.

Fig. 4A is a side view of a device having a temperature-indicating element and a fluid delivery element, according to arrangement not according to the invention.

Fig. 4B is a side view of a device having a temperature-indicating element, a fluid delivery element, and an aspiration element, according to another arrangement not according to the invention.

Figs. 5A-D each schematically represent an electrosurgical device having a temperature-indicating element and an electrode assembly, according to various arrangements not according to the invention.

Figs. 6A-E each schematically represent an electrosurgical device, showing a temperature-indicating element in relation to components of an electrode assembly, according to various arrangement not according to the invention; and Fig. 6F is a plan view of the device of Fig. 6E taken along the lines 6F-6F;

Fig. 7 is a side view schematically representing an electrosurgical device having a temperature-indicating element encased within a sheath, according to another arrangement not according to the invention.

Fig. 8 is a partial longitudinal sectional view of a distal portion of an electrosurgical device having a temperature-indicating element disposed on a temperature indicator base element, according to one arrangement not according to the invention.

Figs. 9A-C each schematically represent a temperature-indicating element disposed on a distal end portion of a shaft of an electrosurgical device, according to three different arrangements not according to the invention.

Fig. 10 is a side view schematically representing a shaft distal end portion of an electrosurgical device having an annular temperature-indicating element, according to another arrangement not according to the invention.

Figs. 11A-C schematically represent a visual change of a temperature-indicating element of a device during a surgical procedure, according to the invention; Fig. 12 is a block diagram schematically representing an endoscopic electrosurgical system, according to another embodiment of the invention; and

Fig. 13 schematically represents an arthroscopic procedure performed using a device having a temperature-indicating element, according to another embodiment of the invention.

Fig. 14 illustrates an electrosurgical probe according to the present invention having a temperature-indicating element positioned on an electrode support.

5  
10  
15  
20  
25  
30  
35  
40  
45  
50  
55

## DESCRIPTION OF SPECIFIC EMBODIMENTS

**[0014]** The present invention provides the electro-surgical instrument of figure 14 for selectively applying energy to a target tissue of a patient, and for monitoring a temperature condition in the region of the target tissue and/or at the working end of a device adapted for such application of energy. The invention is particularly suited to the facile and convenient monitoring of a temperature condition at the working end of a device during an electrosurgical procedure, wherein the temperature may be monitored simply by observing a readily apparent change in the appearance of a temperature indicating element. Such a temperature-indicating element may be integral with the device. The temperature-indicating element is typically disposed at the working end of the device at a location where it is easily viewed by a member of the surgical team during a procedure.

**[0015]** The instrument of the invention are applicable to a broad range of procedures, including: open procedures, intravascular procedures, urological procedures, laparoscopy, arthroscopy, cardiac procedures (including thoracoscopy), dermatologic, orthopedic, gynecological, otorhinolaryngological, spinal, and neurologic procedures, as well as in oncology, and the like. Tissues which may be treated by apparatus of the present invention include, without limitation, connective tissue, including bone and cartilage; prostate tissue; leiomyomas (fibroids) of the uterus; gingival tissues and mucosal tissues of the mouth; tumors; scar tissue; and myocardial tissue; as well as collagenous tissue of the eye, and the dermis and epidermis of the skin.

**[0016]** The present invention is useful for arthroscopic procedures of the knee, shoulder, elbow, etc., including the ablation, re-shaping, or re-surfacing of articular cartilage, and the partial removal or modification of a damaged meniscal cartilage of the knee. The invention is also applicable to a broad range of spinal procedures, including without limitation, laminectomy/discectomy proce-

dures for treating herniated disks, posterior lumbosacral and cervical spine fusions, treatment of scoliosis associated with vertebral disease, and foraminotomies to relieve nerve root compression.

**[0017]** The present invention is also useful for procedures in the head and neck, e.g., targeting the ear, mouth, pharynx, larynx, esophagus, nasal cavity and sinuses. These procedures may be performed through the mouth or nose using speculae or gags, or using endoscopic techniques, such as functional endoscopic sinus surgery (FESS). The present invention may also be used for collagen shrinkage, ablation, and/or hemostasis, e.g., during procedures for treating snoring and obstructive sleep apnea; for gross tissue removal, such as tonsillectomies, adenoidectomies, tracheal stenosis and vocal cord polyps and lesions; or for the resection or ablation of facial tumors or tumors within the mouth and pharynx, such as glossectomies, laryngectomies, acoustic neuroma procedures, and nasal ablation procedures.

**[0018]** The instrument of the present invention may also be useful for cosmetic and plastic surgery procedures. For example, the present invention may be employed for skin tissue removal and/or collagen shrinkage in the epidermis or dermis of the head and neck, e.g., the removal of pigmentations, vascular lesions, scars, tattoos, etc., as well as for other surgical procedures on the skin, such as tissue rejuvenation, cosmetic eye procedures (blepharoplasties), wrinkle removal, tightening muscles for facelifts or brow-lifts, hair removal and/or transplant procedures, etc.

**[0019]** As noted above, although the present invention may be applied to any type of electrosurgical device, including those using (RF) energy, the device is particularly useful in those devices using Coblation® technology (plasma assisted electrosurgical ablation devices).

**[0020]** Coblation® requires application of a high frequency voltage difference between one or more active electrode(s) and one or more return electrode(s) to develop high electric field intensities in the vicinity of the target tissue. The high electric field intensities may be generated by applying a high frequency voltage that is sufficient to vaporize an electrically conductive medium over at least a portion of the active electrode(s) in the region between the distal tip of the active electrode(s) and the target tissue. The electrically conductive medium may be, for example, a liquid, gel or gas. Such electrically conductive medium include isotonic saline, blood, extracellular or intracellular fluid, delivered to, or already present at, the target site, or a viscous medium, such as a gel, applied to the target site.

**[0021]** When the conductive medium is heated enough such that atoms vaporize off the surface faster than they recondense, a gas is formed. When the gas is sufficiently heated such that the atoms collide with each other and knock their electrons off in the process, an ionized gas or plasma is formed (the so-called "fourth state of matter"). Generally speaking, plasmas may be formed by heating a gas and ionizing the gas by driving an electric

current through it, or by shining radio waves into the gas. These methods of plasma formation give energy to free electrons in the plasma directly, and then electron-atom collisions liberate more electrons, and the process cascades until the desired degree of ionization is achieved. A more complete description of plasma can be found in Plasma Physics, by R.J. Goldston and P.H. Rutherford of the Plasma Physics Laboratory of Princeton University (1995).

**[0022]** As the density of the plasma or vapor layer becomes sufficiently low (i.e., less than approximately 1020 atoms/cm<sup>3</sup> for aqueous solutions), the electron mean free path increases to enable subsequently injected electrons to cause impact ionization within the vapor layer). Once the ionic particles in the plasma layer have sufficient energy, they accelerate towards the target tissue. Energy evolved by the energetic electrons (e.g., 3.5 eV to 5 eV) can subsequently bombard a molecule and break its bonds, dissociating a molecule into free radicals, which then combine into final gaseous or liquid species. Often, the electrons carry the electrical current or absorb the radio waves and, therefore, are hotter than the ions. Thus, the electrons, which are carried away from the tissue towards the return electrode, carry most of the plasma's heat with them, allowing the ions to break apart the tissue molecules in a substantially non-thermal manner.

**[0023]** By means of this molecular dissociation (rather than thermal evaporation or carbonization), the target tissue structure is volumetrically removed through molecular disintegration of larger organic molecules into smaller molecules and/or atoms, such as hydrogen, oxygen, oxides of carbon, hydrocarbons and nitrogen compounds. This molecular disintegration completely removes the tissue structure, as opposed to dehydrating the tissue material by the removal of liquid within the cells of the tissue and extracellular fluids, as is typically the case with electrosurgical desiccation and vaporization. A more detailed description of this phenomena can be found in commonly assigned U.S. Patent No. 5,697,882.

**[0024]** In some applications of the Coblation technology, high frequency (RF) electrical energy is applied in an electrically conducting media environment to shrink or remove (i.e., resect, cut, or ablate) a tissue structure and to seal transected vessels within the region of the target tissue. Coblation technology is also useful for sealing larger arterial vessels, e.g., on the order of about 1 mm in diameter. In such applications, a high frequency power supply is provided having an ablation mode, wherein a first voltage is applied to an active electrode sufficient to effect molecular dissociation or disintegration of the tissue, and a coagulation mode, wherein a second, lower voltage is applied to an active electrode (either the same or a different electrode) sufficient to heat, shrink, and/or achieve hemostasis of severed vessels within the tissue. In other applications, an electrosurgical instrument is provided having one or more coagulation electrode(s) configured for sealing a severed vessel, such as an arterial vessel, and one or more active elec-

trodes configured for either contracting the collagen fibers within the tissue or removing (ablating) the tissue, e.g., by applying sufficient energy to the tissue to effect molecular dissociation. A single voltage can be applied to the tissue by the coagulation electrode(s), as well as to the active electrode(s) to ablate or shrink the tissue. In certain applications, the power supply is combined with the coagulation instrument such that the coagulation electrode is used when the power supply is in the coagulation mode (low voltage), and the active electrode(s) are used when the power supply is in the ablation mode (higher voltage).

**[0025]** The amount of energy produced by the Coblation® technology may be varied by adjusting a variety of factors, such as: the number of active electrodes; electrode size and spacing; electrode surface area; asperities and sharp edges on the electrode surfaces; electrode materials; applied voltage and power; current limiting means, such as inductors; electrical conductivity of the medium in contact with the electrodes; density of the medium; and other factors. Accordingly, these factors can be manipulated to control the energy level of the excited electrons. Since different tissue structures have different molecular bonds, the Coblation® device may be configured to produce energy sufficient to break the molecular bonds of certain tissue but insufficient to break the molecular bonds of other tissue. For example, fatty tissue, (e.g., adipose) tissue has double bonds that require an energy level substantially higher than 4 eV to 5 eV (typically on the order of about 8 eV) to break. Accordingly, the Coblation® technology generally does not ablate or remove such fatty tissue; however, it may be used to effectively ablate cells to release the inner fat content in a liquid form. Of course, factors may be changed such that these double bonds can also be broken in a similar fashion as the single bonds (e.g., increasing voltage or changing the electrode configuration to increase the current density at the electrode tips). A more complete description of this phenomena can be found in commonly assigned U.S. Patent Nos. 6,355,032,6,149,120 and 6,296,136.

**[0026]** The active electrode(s) of a Coblation® device are preferably supported within or by an inorganic insulating support positioned near the distal end of the instrument shaft. The return electrode may be located on the instrument shaft, on another instrument or on the external surface of the patient (i.e., a dispersive pad). The proximal end of the instrument(s) will include the appropriate electrical connections for coupling the return electrode(s) and the active electrode(s) to a high frequency power supply, such as an electrosurgical generator.

**[0027]** While Coblation® ablates tissue in a non-thermal manner, surface temperature of the tissue has been observed to be in the range of 40-70°C. Accordingly, it still may be desirable for the medical practitioner to have the ability to directly observe the temperature environment of the surgical site when using a Coblation® device. However, it is noted that the invention described herein

may be applied to any type of surgical instrument which generates heat either directly, or as a by-product of the procedure. For example, the invention may be incorporated in devices using microwave energy, laser, UV light based, mechanical energy, etc. It is noted that the device has particular value in thermal electrosurgical devices.

**[0028]** In one embodiment of the present invention, radio frequency (RF) electrical energy is applied to one or more active electrodes of a device in the presence of an electrically conductive fluid, to remove and/or modify at least a portion of a target tissue or organ. Depending on the specific procedure, the present invention may be used to: (1) ablate (i.e., volumetrically remove or effect the molecular dissociation of) tissue, including soft tissue, bone, and cartilage; (2) cut or resect tissue; (3) shrink or contract collagen containing tissue; and/or (4) coagulate, occlude, and sever blood vessels.

**[0029]** Typically, devices of the invention are adapted for coupling to an electrosurgical generator incorporating a RF power supply, wherein the power supply is capable of operation in an ablation mode (for ablating tissue), or a sub-ablation mode (for coagulating or otherwise modifying the tissue). Typically, electrosurgical devices of the invention will include one or more electrode leads by which the electrode(s) are connected to a connection block. The connector is adapted for coupling the electrode(s) to the generator or power supply. Typically, the connector includes a plurality of pins for coupling to the power supply via a connector cable.

**[0030]** Devices of the invention may use a single active electrode or an electrode array distributed over a working end of the device. In the latter embodiment, the electrode array may include a plurality of independently current-limited and/or power-controlled active electrodes to apply electrical energy selectively to the target tissue while limiting the unwanted application of electrical energy to the surrounding tissue and environment. In one configuration, each individual active electrode in the electrode array is electrically insulated from all other active electrodes in the array, and each active electrode is connected to a power source which is isolated from each of the other active electrodes in the array, or to circuitry which limits or interrupts current flow to the active electrode when low resistivity material (e.g., blood, saline) causes a lower impedance path between the return electrode and the particular active electrode. Apparatus incorporating independently current-limited and/or power-controlled active electrodes is described in commonly assigned US Patent No. 6,312,408.

**[0031]** The voltage applied between the active and return electrodes will typically be in the radio frequency (RF) range, having a frequency between about 5 kHz and 20 MHz, usually being between about 30 kHz and 2.5 MHz, and often between about 100 kHz and 200 kHz. The RMS (root mean square) voltage applied will usually be in the range from about 5 volts RMS to 1500 volts RMS, typically being in the range of from about 10 volts RMS to 900 volts RMS, and often in the range of from

about 20 volts RMS to 500 volts RMS, depending on the active electrode size and geometry, the operating frequency, and the particular procedure or desired effect on the tissue (e.g., ablation, contraction, coagulation). Typically, the peak-to-peak voltage will be in the range of 10 to 2000 volts, usually in the range of 20 to 1200 volts, and often in the range of about 40 to 800 volts (again, depending on the electrode size, the operating frequency, and the operation mode). Voltage parameters for various electrosurgical procedures are presented in commonly assigned US Patent No. 6,235,020.

**[0032]** The voltage is typically delivered in a series of voltage pulses or "alternating current of time varying voltage amplitude having a sufficiently high frequency (e.g., on the order of 5 kHz to 20 MHz) such that the voltage is effectively applied continuously (as compared with, e.g., certain lasers adapted for shallow depths of tissue necrosis, which are generally pulsed at about 10 Hz to 20 Hz). In addition, the duty cycle (i.e., cumulative time in any one-second interval that energy is applied) is on the order of about 50% for apparatus of the present invention, as compared with a duty cycle of about 0.0001% for many pulsed lasers.

**[0033]** A preferred power supply of the present invention delivers a high frequency current selectable to generate average power levels ranging from several milliwatts to tens of watts per electrode, depending on the volume of target tissue being treated, and/or the maximum allowed temperature selected for the probe tip. The power supply allows the user to select the voltage level according to the specific requirements of a particular procedure, e.g., FESS procedure, dermatological procedure, ophthalmic procedure, arthroscopic surgery or other endoscopic surgery, or open surgery. A description of a power supply adapted for electrosurgery can be found in commonly assigned US Patent No. 6,142,992.

**[0034]** A current flow path between the active and return electrodes may be provided by delivering an electrically conductive fluid (e.g., an electrically conductive gel or saline) to the working end of the device. To provide a suitable current flow path between the active and return electrodes, an electrically conductive fluid delivered to the working end of the device should have a suitable electrical conductivity, typically at least 0.2 millisiemens per centimeter (mS/cm), usually greater than 2 mS/cm, and often greater than 10 mS/cm. In one embodiment, the electrically conductive fluid is isotonic saline, which has a conductivity of about 17 mS/cm. In other embodiments, electrically conductive fluids having electrical conductivity values much higher than that of isotonic saline may also be used. A discussion of various electrically conductive fluids, having a range of electrical conductivity values, suitable for use in electrosurgery appears in commonly assigned US Patent No. 6,149,620. Delivery of an electrically conductive fluid to provide a current flow path between the active and return electrodes is described in commonly assigned US Patent Nos. 5,697,281 and 6,312,408.

**[0035]** In some procedures, it may also be necessary to retrieve or aspirate excess or unwanted materials, e.g., saline, ablation by-products, from the target site. For example, in procedures in the nose, mouth or throat, it may be desirable to aspirate saline so that it does not flow down the patient's throat. In addition, it may be desirable to aspirate resected tissue fragments, blood, mucus, gaseous ablation by-products, etc., from the surgical site. Accordingly, systems of the invention may include an aspiration element or lumen, which may be integral with the device, for aspirating materials from the target site. Furthermore, in some embodiments the device may include one or more aspiration electrode(s) (or digestion electrode(s)) for ablating, or reducing the volume of, resected tissue fragments that are aspirated into the aspiration lumen. Devices incorporating aspiration electrodes are described in commonly assigned US Patent Nos. 6,238,391 and 6,254,600.

**[0036]** Fig. 1 illustrates an electrosurgical system 200 for use with the present invention. System 200 is adapted for performing a procedure on a patient and for estimating a temperature condition at, or adjacent to, a surgical site during the procedure. System 200 includes an exemplary device 201 coupled to a power supply 228.

**[0037]** Device 201 is in the form of a probe or catheter which includes a shaft 202 having a shaft distal end portion 202a, and a shaft proximal end portion 202b attached to a handle 204 which accommodates a connector 206. In this variation the connector 206 is fixed to the shaft 202 via the handle 204. An electrode assembly 210 is operatively disposed at distal end portion 202a. Typically, electrode assembly 210 includes at least one active electrode and at least one return electrode disposed on an electrically insulating electrode support or spacer (e.g., Figs. 6A-F). Electrode assembly 210 is adapted for applying energy to a target tissue of a patient. Typically, electrode assembly 210 is disposed at the working or distal end of the device. The distal end of probe 201, including electrode assembly 210, may have various configurations, e.g., as described in commonly assigned U.S. Patent No. 6,296,638.

**[0038]** The connector 206 may be within the handle 204 to provide a mechanism for conveniently coupling device 201 to power supply 228, for example, via a connection cable 260. Power supply 228 is adapted for supplying electrical energy to electrode assembly 210. Power supply 228 may comprise, for example, a RF power supply adapted for applying a high frequency alternating-current voltage (ac voltage) to electrode assembly 210.

**[0039]** In an alternative variation of the invention, a connector 206 may be fixedly attached to a cable 260 (e.g., an integrated cable/connector). In such a case, the cable 260 may have a distal end that is fixed to the connector 206, handle 204, and/or shaft 202. A proximal end of the cable 260 will be adapted to engage the power-supply 228 either fixedly or removably.

**[0040]** Device 201 may further include a fluid delivery unit (not shown) adapted for delivering a fluid, such as

an electrically conductive liquid (e.g., saline), to electrode assembly **110** and/or to a target tissue during a procedure. Device **201** may further include an aspiration unit (not shown) adapted for aspirating excess or unwanted materials, e.g., excess fluid, resected tissue fragments, and gaseous ablation by-products, from the surgical site during a procedure. The fluid delivery and aspiration units may each take various forms, typically including a proximal tube coupled to a lumen running internal or external to shaft **202**, and a distal port (for example, a fluid delivery port or an aspiration port (e.g., Figs. 4A-B)).

**[0041]** The inventive probe **201** further includes one or more visual temperature-indicating elements **250**. Typically, temperature-indicating element **250** is disposed at a location, e.g., exposed on an external surface of shaft distal end portion **202a**, where it can be easily viewed by an operator of probe **201**, e.g., by viewing element **250** with the naked eye, or via a fiber optic light source and camera (e.g., Fig. 13).

**[0042]** Often, temperature-indicating element **250** is disposed at the distal end portion of shaft **202**, e.g., on, adjacent to, superior to (above), or proximal to electrode assembly **210** (e.g., Figs. 5A-D, 6A-F) but may be disposed at any point along shaft **202** at a location proximal thereto. For illustrative purposes, the return electrode **211** is shown to be proximal to the support matrix **211**. However, the return electrode **211** may be located anywhere along the device. In addition, more than one temperature-indicating element may be employed at one or more locations on shaft **202**. For example, one or more elements **250a** may be positioned at the working distal end of shaft **202** (see Figs. 2A and 2C) to indicate the temperature of a target tissue being treated, while one or more other elements **250b** may be positioned at a location proximally along the shaft **202** (see Figs. 2B and 2C) to indicate the temperature of the conductive fluid return. In the variation shown in Fig. 2, the temperature-indicating element **250** is placed about a support matrix **212** which retains the electrodes **210**.

**[0043]** One variation of the visual temperature-indicating element **250** typically includes a thermochromic layer of a composition or material, such as an organic polymer in the form of a leuco dye or a liquid crystal, which exhibits a pronounced or readily discernible change in appearance upon exposure to a pre-defined temperature or temperature regime (temperature/time combination). The thermochromic composition is adapted or formulated to undergo one or more distinct visual changes (for example, but not limited to a change in color, shade, hues, saturations or contrasts) upon reaching a particular temperature or range of temperatures. Such change(s) in color may include changing from a colored state to a colorless state or visa-versa, from a dark color to a lighter color or visa-versa. In response to this visual change, application of energy via probe **201** can be discontinued, or the energy level can be decreased.

**[0044]** The present invention may incorporate any number of various types and formulations of thermochromic

compositions, including paints, inks, plastics, rubbers, labels, self-adhesive strips, crayons, and synthetic films or sheets, are well known in the art (see, for example, Encyclopedia of Chemical Technology, Fourth Edition, J.I. Kroschwitz & M. Howe-Grant, Eds., Published by John Wiley & Sons, Inc.) and may be used with the present invention. A broad range of thermochromic paints are commercially available, e.g., from Lakfabriek Korthals BV, Postbus 135, 1970 AC IJmuiden, The Netherlands and from TMC, Northbrook, IL. Thermochromic liquid crystal Mylar sheets are available, for example, from Omega Engineering, Inc., Stamford, CT. One thermochromic ink suitable for use with the present invention is DynaColor™ epoxy screen ink distributed by Chromatic Technologies, Incorporated. This ink is colored below a specific temperature and changes to colorless or to another, lighter color as it is heated through a defined temperature range. This color change is reversible in that the original color is restored upon cooling of the ink.

**[0045]** It may be desirable to place provide some type of protective covering for the temperature element. For example, the thermochromic materials for use with the present invention may be applied to an external surface of a device and then covered by a biocompatible sheath, e.g., comprising a transparent or translucent plastic. Such a sheath may be electrically and/or thermally insulating. In the latter case, the activation temperature of temperature element may be affected by the insulation. However, simple experimentation allows for proper selection of the temperature range of the element and notice as to what external temperature event affects the element.

**[0046]** The temperature element may be formulated with other materials to modify or enhance their color change characteristics. For example, a thermochromic composition may be encapsulated within microscopic capsules or microcapsules, e.g., having diameters in the range of from about 1 μm to 10 μm, and added to a host medium (e.g., a polymer or pigmented resin) to provide a thermochromic composition.

**[0047]** The temperature above which the temperature element begins to change visual appearance shall be referred to as the initial activation temperature of an activation temperature range. The temperature at which the temperature element completes the visual transformation shall define the upper limit of the activation temperature range. The activation temperature range of the temperature element is often a function of the chemical structure or physical configuration of the element or composition forming the element. The thermochromic activation temperature range can be tailored by chemical modification of components of the composition, and/or by adjusting the proportions of one or more components of the composition. The activation temperature range is variable and may be optimized according to the particular type of tissue being treated, e.g., bone, skin, cartilage, and the intended effect on the tissue, e.g., ablation, contraction. For example, a first device intended for ablating hard

connective tissue during an arthroscopic procedure may be provided with a first temperature indicating element adapted to indicate a first pre-defined temperature; whereas a second device intended for shrinking collagen containing tissue during a cosmetic procedure may be provided with a second temperature indicating element adapted to indicate a second pre-defined temperature. Typically, the temperatures to be monitored during electrosurgical procedures are well within this range (e.g., from about 40°C to 95°C). As one example only, and not to limit the invention in any way, the temperature-indicating element may comprise a material that undergoes a distinct, readily recognized color change when it experiences a temperature increase to 65°C.

**[0048]** The temperature-indicating element may be selected to have more than one specific activation temperatures or temperature ranges. Some thermochromic compositions may undergo a series of color changes with change in temperature, *i.e.*, the temperature-indicating element composition may exhibit a plurality of different colors as the temperature changes, wherein at least one of the different colors is indicative of a particular temperature value or temperature range. For example, the temperature-indicating element may have three activation temperatures, e.g., 45°C, 65°C and about 80°C, where the element changes colors upon a change from a preferred temperature or range to an unacceptable temperature or range, that latter of which may indicate a temperature at which tissue is at a risk of becoming damaged. Thermochromic liquid crystalline materials, e.g., cholesteric liquid crystals, nematic liquid crystals, and smectic liquid crystals, are highly suitable for such an application. Each thermochromic liquid crystal composition typically exhibits a range of color changes as the temperature changes (increases and decreases) through a defined temperature range. For example, as the temperature increases through a particular temperature range, the composition may change from brown to red, then yellow, green, blue, violet, and black. Liquid crystals may be categorized according to their red start (or "event") temperature and bandwidth (see, for example, the article by D.J. Farino, entitled Making Surface Temperature Measurements Using Liquid Crystal Thermography ([http://www.electronics-cooling.com/Resources/EC\\_Articles/OCT95/oct95\\_01.htm](http://www.electronics-cooling.com/Resources/EC_Articles/OCT95/oct95_01.htm))).

**[0049]** In some embodiments, the temperature value indicated by the temperature-indicating element may directly provide a useful estimate of the tissue temperature. In other embodiments, a correction factor may be used to estimate a temperature of the target tissue, based on the temperature value indicated by the temperature-indicating element. The value of such a correction factor may depend, for example, on the location of the temperature-indicating element with respect to the active electrode(s), parameters of the voltage applied to the active electrode(s), and other parameters. As an example only, consider a procedure in which it is desired to heat the

target tissue to a temperature of  $y^{\circ}\text{C}$ . In a situation where the temperature differential between the temperature indicating element and the target tissue is  $x^{\circ}\text{C}$ , the temperature-indicating element can be adapted to show a change in appearance at a temperature of  $(y-x)^{\circ}\text{C}$ . Such a change in appearance of the temperature-indicating element may comprise, for example, an alpha-numeric signal, e.g., a text message (see, e.g., Fig. 9C).

**[0050]** Fig. 3 schematically represents a system **300** including an electrosurgical catheter **301**, according to another embodiment of the invention. System **300** has certain features and characteristics similar or analogous to those of electrosurgical apparatus described hereinabove, e.g., with reference to Fig. 1. Catheter **301** includes a shaft having a shaft distal end portion **302a** and a shaft proximal end portion **302b**. An electrode assembly **310** and a temperature-indicating element **350** are disposed at shaft distal end portion **302a**. Electrode assembly **310** is schematically represented in Fig. 3. In practice, assembly **310** may include one or more active electrodes or an active electrode array, and at least one return electrode.

**[0051]** Temperature-indicating element **350** is also represented generically in Fig. 3. Typically, temperature-indicating element **350** comprises a thermochromic composition adapted to undergo at least one thermochromic transition at a pre-defined temperature. The thermochromic transition temperature(s) of temperature-indicating element **350** are usually in the range of from about 40°C to 95°C. Temperature-indicating element **350** may have various characteristics, elements, and features as described with respect to other embodiments of the invention, e.g., with reference to Figs. 6A-10. Temperature-indicating element **350** may be used to estimate temperature in the region of electrode assembly **310** and, indirectly, to monitor tissue temperature at a surgical site during an electrosurgical procedure, as is described herein, e.g., with reference to Fig. 2.

**[0052]** System **300** further includes a power supply **328**, and a connector cable **360** for coupling catheter **301** to power supply **328**. Typically, catheter **301** further includes a connector **306** adapted for receiving connector cable **360** and for coupling electrode assembly **310** to power supply **328**. In one embodiment, power supply **328** is adapted to supply RF power to electrode assembly **310**. Of course, the invention is not limited to the configuration shown in Fig. 3, but rather, many other configurations are also possible under the invention.

**[0053]** Fig. 4A is a side view of an electrosurgical device or probe **401**, according to one embodiment of the invention. Probe **401** includes a shaft **402** having a shaft distal end portion **402a** and a shaft proximal end portion **402b**, and a handle **404**. Probe **401** further includes a temperature-indicating element **450** and an electrode assembly **410**, both disposed at shaft distal end portion **402a**. Both temperature-indicating element **450** and electrode assembly **410** are represented generically in Fig. 4A. Temperature-indicating element **450** and electrode

assembly **410** may include various elements and features as described herein with respect to other embodiments of the invention (e.g., with reference to Figs. 5A-10).

**[0054]** Probe **401** further includes a fluid delivery element comprising a proximal fluid delivery tube **436**, a fluid delivery lumen **434**, and a distal fluid delivery port **432**. The fluid delivery element is adapted for delivering a controlled amount of fluid to the working end of probe **401**, or to a target tissue, during a procedure. Fluid delivery tube **436** may be adapted for connection to a suitable fluid source, which may be gravity fed or powered by a pump, as is well known in the art. As shown, lumen **434** lies internal to shaft **402**, however, the invention is by no means limited to this configuration.

**[0055]** A fluid delivered to the distal or working end of device **401**, or to a target tissue, is represented in Figs. 4A-B by solid arrows. The fluid delivered by the fluid delivery element may be an electrically conductive fluid (e.g., saline) which completes a current flow path between the active and return electrodes of electrode assembly **410** (e.g., Figs. 6A-F). Saline delivered by the fluid delivery element may also promote initiation and maintenance of a plasma in the vicinity of the active electrode(s) upon application of a suitable high frequency voltage thereto (e.g., during the Coblation® process, as described hereinabove).

**[0056]** According to one aspect of the invention, a region surrounding the target tissue and the working end of an electrosurgical device may be submersed in a fluid. For example, during certain arthroscopic procedures, a fluid delivered by the device may substantially fill the cavity of a synovial joint. Saline delivered to a target tissue during a procedure may have a NaCl concentration greater than that of isotonic saline. Furthermore, a fluid delivered during a procedure may be a salt solution other than NaCl solution (saline). Various electrically conductive fluids for use in electrosurgery according to the instant invention are described in commonly assigned U.S. Patent No. 6,149,620.

**[0057]** Fig. 4B is a side view of a device or probe **401'**, according to another embodiment of the invention. Probe **401'** includes a number of elements in common with previously described embodiments, e.g., that described with reference to Fig. 4A. Briefly, probe **401'** includes a temperature-indicating element **450'** and an electrode assembly **410'**, both disposed at shaft distal end portion **402a'**. Probe **401'** further includes a fluid delivery element comprising a proximal fluid delivery tube **436'**, a fluid delivery lumen **434'**, and a distal fluid delivery port **432'**. In the embodiment shown in Fig. 4B, fluid delivery lumen **434'** takes the form of an annular gap lying external to shaft **402'**. Apparatus having an annular fluid delivery element are described in commonly assigned US Patent No. 6,066,134.

**[0058]** Probe **401'** still further includes an aspiration element comprising a proximal aspiration tube **446'**, an aspiration lumen **444'**, and a distal aspiration port **442'**.

The aspiration element is adapted for aspirating excess or unwanted materials, such as, blood, saline, resected tissue fragments, gaseous ablation by-products, etc., from the surgical site during a procedure. Aspiration tube **446'** may be adapted for coupling to a suitable vacuum source, as is well known in the art. As shown in Fig. 4B, aspiration lumen **444'** lies internal to shaft **402'**; however, the invention is by no means limited to this configuration. In some embodiments, the probe may include one or more aspiration electrodes (not shown) adapted for digesting resected tissue fragments, or other debris, drawn into aspiration port **442'** via an aspiration stream (represented in Fig. 4B by open arrows). An apparatus having an aspiration element is described in commonly assigned US Patent No. 6,238,391.

**[0059]** Figs. 5A-D each schematically represents an electrosurgical device **501a-d**, respectively, according to various embodiments of the instant invention. Devices **501a-d** have temperature-indicating elements **550a-d** and electrode assemblies **510a-d**, respectively. Temperature-indicating elements **550a-d** and electrode assemblies **510a-d** are represented more or less generically in Figs. 5A-D. Size, dimension, and location of the temperature indicating elements **550a-d** shown is only for illustrative purposes. The temperature indicating elements **550a-d** may be placed about the shaft **502** of the device or it may be located in discrete places on the device. Furthermore, more than one temperature indicating element **550a-d** having either the same activation temperature range or different activation temperature ranges may be used. For example, Fig. 5D illustrates a second temperature-indicating element **550e** on a device **501c**. In practice, temperature indicating elements **550a-d** and electrode assemblies **510a-d** may each include various elements or features as described herein with respect to other embodiments of the invention. For example, temperature-indicating elements **550a-d** may each comprise: a thermochromic paint applied directly to the device or applied over a primer; an adhesive label, tape, or other printable medium incorporating a thermochromic composition (e.g., a thermochromic ink); a thermochromic synthetic film; an annular band of a rubber or a plastic; or a plurality of thermochromic cells. In the latter case, each cell may have the same or different thermochromic compositions contained therein or applied thereto.

**[0060]** The temperature-indicating elements **550a-d** may comprise, for example, a leuco dye, or a liquid crystal having a suitable red start temperature and bandwidth. The liquid crystal may be, for example, a cholesteric liquid crystal. Thermochromic liquid crystal formulations are available with start temperatures ranging from <-30°C to >+100°C, and bandwidths ranging from about 0.5°C to 30°C. The temperature-indicating elements **550a-d** may be encapsulated in a plurality of microcapsules. (Microencapsulated thermochromic compositions are commercially available, e.g., from Hallcrest, Inc., Glenview, IL.) Alternatively, one or more of elements **550a-d** may comprise a thermochromic liquid crystal Mylar® sheet or film.

A broad range of thermochromic materials may be formulated to undergo a specific color change at pre-defined transition temperatures, as is well known in the art.

[0061] In the embodiment of Fig. 5A, device or probe **501a** includes a shaft **502** having a shaft distal end portion **502a** and a shaft proximal end portion **502b**. A handle **504** is attached to shaft proximal end portion **502b**. Electrode assembly **510a** is disposed axially at the apex or terminus of shaft **502**, and temperature indicating element **550a** is disposed on shaft distal end portion **502a** proximal to electrode assembly **510a**. Electrode assembly **510a** includes a treatment surface **518** adapted for being positioned with respect to a target tissue during a procedure. For sake of clarity, a return electrode is not illustrated on Figs. 5A-5D.

[0062] With reference to Fig. 5B, probe **501b** includes certain elements in common with the embodiment described with reference to Fig. 5A. Only the distal or working end of probes **501b-d** are shown in Figs. 5B-D. Probe **501b** has electrode assembly **510b** disposed axially at the terminus of shaft **502**, and temperature indicating element **550b** is disposed on electrode assembly **510b**.

[0063] Fig. 5C shows probe **501c** including shaft **502** having a curved shaft distal end portion **502a**. Electrode assembly **510c** is disposed at the terminus of shaft **502**, and temperature indicating element **550c** is disposed proximal to electrode assembly **510c**. Other arrangements for an electrode assembly and a temperature-indicating element on a curved shaft are also possible under the invention.

[0064] Fig. 5D shows a probe **501d** having electrode assembly **510d** at shaft distal end portion **502a**. Electrode assembly **510d** includes treatment surface **518** adapted for opposing or contacting a target tissue during a procedure. As shown in Fig. 5D, treatment surface **518** is arranged laterally on shaft **502**. Temperature-indicating element **550d** is disposed on electrode assembly **510d** at a superior location, where it is readily visible to a surgeon performing a procedure using probe **501d**. It is to be understood that the invention is not limited to those configurations shown in Figs. 5A-D. Furthermore, each of probes **501a-d** may include various elements and features as described herein for other embodiments of the invention. For example, one or more of probes **501a-d** may include a fluid delivery element, and/or an aspiration element (e.g., Figs. 1, 4A-B).

[0065] Figs. 6A-E each schematically represents an electrosurgical device **601a-e**, respectively, according to various embodiments of the instant invention. Each of Figs. 6A-E shows a temperature indicating element **650a-e** in relation to components of an electrode assembly. With reference to Fig. 6A, probe **601a** includes a shaft **602** having a shaft distal end portion **602a** and a shaft proximal end portion **602b**. A handle **604** is attached to shaft proximal end portion **602b**. An electrode assembly **610a** is disposed at shaft distal end portion **602a**. Electrode assembly **610a** includes a distal active electrode or electrode array **612a** disposed on an electrically

insulating electrode support or spacer **614a**, and a return electrode **616a**.

[0066] Active electrode(s) **612a** may have a wide variety of configurations, and each active electrode or electrode terminal may comprise a metal such as stainless steel, molybdenum, platinum, tungsten, palladium, iridium, titanium, or their alloys, and the like. Spacer **614a** may comprise, for example, a ceramic, a glass, or a silicone rubber. Return electrode **616a** may comprise, for example, an annular band of a metal, such as stainless steel, molybdenum, platinum, tungsten, palladium, iridium, titanium, or their alloys. As an example only, various electrode configurations that may be used in conjunction with the instant invention are described in commonly assigned US Patent No. 6,296,638.

[0067] Again with reference to Fig. 6A, probe **601a** further includes temperature-indicating element **650a** disposed on shaft distal end portion **602a** at a location proximal to return electrode **616a**. Temperature-indicating element **650a** may comprise non-toxic (or low toxicity), FDA-approved, biocompatible materials, or maybe encased within such materials. In some embodiments, the temperature-indicating element may be covered by a sheath of biocompatible material (see, e.g., Fig. 7), which may be transparent or translucent. In such instances, the patient's tissue is shielded from direct contact with components of the temperature-indicating element during a procedure.

[0068] Figs. 6B-E show, in side view, the working or distal end of probes **601b-e**, respectively. Each of probes **601b-e** may have features or elements the same, similar, or analogous to those described hereinabove, e.g., with reference to Fig. 6A. With reference to Fig. 6B there is shown probe **601b** having a distal active electrode **612b** disposed on an electrically insulating electrode support **614b**, and a proximal return electrode **616b**. Temperature indicating element **650b** of probe **601b** is disposed on return electrode **616b**.

[0069] In the embodiment of Fig. 6C, temperature indicating element **650c** is disposed distal to return electrode **616c** and proximal to spacer **614c**. Return electrode **616c** is shown as an annular band disposed on shaft distal end portion **602a**. However, other configurations for the return electrode are also within the scope of the invention.

[0070] Fig. 6D shows a distal active electrode **612d** disposed on an electrically insulating spacer **614d**, and a return electrode **616d** disposed proximal to spacer **614d**. In the embodiment of Fig. 6D, temperature-indicating element **650d** is disposed on spacer **614d** between active electrode **612d** and return electrode **616c**.

[0071] In the embodiment of Fig. 6E, electrically insulating electrode support or spacer **614e** is arranged laterally on shaft distal end portion **602a**. A plurality of active electrodes **612e**, or an array of active electrode terminals, is arranged on spacer **614e**. Return electrode **616e** is disposed superior to (above) spacer **614e**. Fig. 6F is a plan view of the device of Fig. 6E taken along the lines

6F-6F. Temperature-indicating element **650e** is disposed at a superior location on return electrode **616e**. As shown in Fig. 6F, temperature-indicating element **650e** is represented as being substantially rectangular in outline with its long axis arranged substantially orthogonal to the longitudinal axis of probe **601e**. However, other configurations for the temperature-indicating element are also within the scope of the invention. Temperature-indicating elements of the invention, e.g., element **650e**, typically have a length, *l* in the range of from about 1 mm to 3 cm, more usually from about 2 mm to 2 cm, and often from about 3 mm to 1 cm; and typically have a width, *w* in the range of from about 1 mm to 5 cm, more usually from about 2 mm to 3 cm, and often from about 3 mm to 2 cm. Of course, in some embodiments the temperature-indicating element may comprise an annular band which encircles the shaft (see, e.g., Fig. 10).

**[0072]** Each of temperature-indicating elements **650a-e** may comprise a suitable thermochromic composition, appropriately selected or formulated to provide a discernible change in appearance (e.g., a color change) in response to a specific temperature condition or temperature regime. In some embodiments, the temperature-indicating element may be affixed directly to various components of the probe or device. Alternatively, an additional component, for example, a temperature indicator base, may be affixed to the probe, and the temperature-indicating element **650a-e** may be disposed on the temperature indicator base (see, e.g., Fig. 8).

**[0073]** Shafts **602a-e** are shown in Figs. 6A-E as being essentially linear or straight. However, according to the invention the shaft, and in particular the shaft distal end portion, may be bent or curved at various angles, typically in the range of from about 5° to 90° to the longitudinal axis of the probe. A suitably curved shaft may facilitate access or manipulation of the working end of the device with respect to a target tissue during certain procedures. Devices having curved shafts are described in commonly assigned US Patent No. 6,296,638.

**[0074]** Fig. 7 is a side view schematically representing an electrosurgical device **701** having a temperature-indicating element encased within a sheath, according to another embodiment of the invention. Only the distal or working end of device **701** is shown in Fig. 7. Device **701** may include various elements or features the same, similar, or analogous to those of other embodiments of the invention, e.g., as described herein with reference to Figs. 1-10. Fig. 7 shows a distal active electrode **712** disposed on an electrically insulating electrode support **714**, and a proximal return electrode **716**.

**[0075]** A temperature-indicating element **750** is disposed on shaft distal end portion **702a** at a location proximal to return electrode **716**. Other configurations for the return electrode and temperature-indicating element are also within the scope of the invention. Temperature-indicating element **750** typically includes a thermochromic composition, such that temperature-indicating element **750** undergoes a readily discernible change in appear-

ance in response to a pre-defined change in temperature, e.g., at one or more thermochromic transition temperatures of the thermochromic composition. For many electrosurgical procedures, the one or more pre-defined temperatures will usually be within the range of from about 40°C to 95°C.

**[0076]** In the embodiment of Fig. 7, device **701** includes a sheath **770** of biocompatible material lying external to shaft **702**. Sheath **770** extends distally to a point whereby temperature-indicating element **750** is at least partially covered by sheath **770**. As an example, sheath **770** may comprise a shrink wrap tube. In some embodiments, sheath **770** may completely cover temperature-indicating element **750**, such that a patient's tissue is shielded from temperature-indicating element **750**, by sheath **770**, during a procedure. In one embodiment, sheath **770** is a transparent or translucent layer which allows a user (surgeon) of device **701** to easily view indicating element **750** while operating device **701**. Sheath **770** may extend proximally from a location distal of temperature indicating element **750** to the handle of device **701**.

**[0077]** Sheath **770** may comprise a polymeric material, such as various plastics. In some embodiments, sheath **770** may comprise an electrically insulating cover over shaft **702**, and sheath **770** may terminate at a defined location on shaft distal end portion **702a** to define return electrode **716** as an exposed portion of shaft **702**. It is to be understood that the invention is by no means limited to the electrode configuration shown in Fig. 7.

**[0078]** According to another embodiment, sheath **770** may comprise a transparent or translucent colored material having a first color (e.g., blue), while indicating element **750** may be colored (e.g., yellow) at body temperature and may become colorless and translucent at an elevated temperature, such that the appearance of element **750**, as seen through sheath **770**, changes in color (e.g., from green to blue) at the elevated temperature. As an example, certain thermochromic compositions are known to exhibit a thermochromic transition from opaque and colored to colorless and translucent with changing temperature.

**[0079]** In another embodiment, sheath **770** may itself comprise a thermochromic material which either allows visualization, or changes the appearance, of an underlying element, only under certain pre-defined temperature conditions. For example, sheath **770** may comprise a thermochromic composition that changes from opaque to transparent at a pre-defined temperature to reveal one or more alpha-numeric characters lying below sheath **770**.

**[0080]** Fig. 8 is a partial longitudinal sectional view of a distal or working end of an electrosurgical device **801**, according to one embodiment of the invention. Device **801** includes a shaft **802** having a shaft distal end portion **802a**. Device **801** typically includes certain elements or features that are at least somewhat analogous to those described for other embodiments of the invention, e.g., with reference to Figs. 2-3, 6A-F. Thus, device **801** will

typically include an electrode assembly disposed at shaft distal end portion **802a**. (The electrode assembly is omitted from Fig. 8 for the sake of clarity.)

**[0081]** Device **801** further includes a temperature indicator base or pad **880** disposed on shaft distal end portion **802a**. Device **801** still further includes a temperature indicating element **850** disposed on indicator base **880**. Indicator base **880** may serve a range of different functions, and may comprise various materials or compositions. The composition of indicator base **880** is typically dependent, at least in part, on the intended function of base **880**. According to one embodiment, base **880** may comprise a thermally insulating or thermally reflective material, wherein base **880** serves to thermally insulate or isolate temperature indicating element **850** from shaft **802**. According to one embodiment, base **880** may comprise an electrically insulating material which serves to electrically insulate element **850** from other components of device **801**.

**[0082]** In another embodiment of the invention, indicator base **880** may comprise a material adapted to affix, or adhere, element **850** to shaft **802**. For example, in embodiments where element **850** comprises a thermochromic paint, base **880** may comprise a primer layer to which the thermochromic paint is applied. In another example, temperature-indicating element **850** may comprise a printable medium printed with thermochromic ink, and base **880** may comprise an adhesive for affixing the printable medium to shaft **802**. In another embodiment, base **880** may be adapted to maximize or promote the appearance of element **850** before and/or after a thermochromic transition (change in color). For example, base **880** may be variously colored (e.g., black or white, depending on the color change(s) of the thermochromic material) to enhance visualization of the thermochromic transition of element **850**. In other embodiments, indicator base **880** may be omitted, and a thermochromic paint or varnish, a printable medium, or a thermochromic film may be applied directly to shaft **802**, with or without a covering element (e.g., a light-transmitting sheath, Fig. 7). Media printable with thermochromic ink include synthetic films, glass, ceramics, thermoplastics, and various fabrics. Thermochromic inks and thermochromic paints are commercially available, e.g., from Matsui International Co., Inc., Gardena, CA.

**[0083]** Figs. 9A-C each schematically represent an electrosurgical device having a temperature indicating element disposed on a distal end portion of a shaft of the device, according to three different embodiments of the instant invention. Fig. 9A shows a distal end portion **902a** of a shaft **902** of a device, as seen in plan view (e.g., Fig. 6F). The device includes a temperature-indicating element **950** disposed at shaft distal end portion **902a**. Indicating element **950** comprises a plurality of thermochromic cells **954a-n**. Five such thermochromic cells are shown in Fig. 9A, although other numbers are also within the scope of the invention.

**[0084]** In one embodiment, each of the plurality of ther-

mochromic cells **954a-n** comprises a different thermochromic composition, such that each cell **954a-n** has different, defined thermochromic properties. For example, each cell **954a-n** may have a different thermochromic transition temperature. Thus, the plurality of cells **954a-n** may undergo a color change at a corresponding plurality of different temperatures. In some embodiments, indicating element **950** may be configured such that cells **954a-n** sequentially undergo a thermochromic transition, e.g., from left to right, as the temperature at shaft distal end portion **902a** increases within a defined temperature range. For example, cells **954a**, **954b**, **954c**, and **954d** may successively undergo a thermochromic transition at temperatures of 50°C, 55°C, 60°C, and 65°C, respectively. The type of color change, e.g., from a first color to a second color, or from a colored to a colorless state, may be the same or different for cells **954a-n**.

**[0085]** Indicating element **950** may be arranged circumferentially on shaft distal end portion **902a**, and indicating element **950** may conform to the external surface of shaft **902**. Typically, the device of Fig. 9A will include an electrode assembly having at least one active electrode. Electrode(s) are omitted from Fig. 9A for the sake of clarity.

**[0086]** Fig. 9B is a plan view of the distal or working end of an device, showing a temperature indicating element **950'** disposed at shaft distal end portion **902a**. Temperature-indicating element **950'** is configured to display one or more of a plurality of numeric values according to a defined temperature condition of shaft distal end portion **902a**. As shown, a plurality of numeric values is indistinctly visible, while one numeric value is distinctly displayed to indicate a temperature corresponding to the displayed numeric value (i.e., 55°C). In alternative embodiments, all numeric values other than that indicative of the actual temperature condition may be invisible. As an example, numeric values corresponding to a range of temperatures, or other alpha-numeric characters, may be made to sequentially appear at particular thermochromic transition temperatures by formulating a plurality of thermochromic compositions to undergo a color change at those temperatures corresponding to each of the plurality of numeric values.

**[0087]** In one embodiment, indicating element **950'** may comprise a plurality of thermochromic cells (see, e.g., Fig. 9A). Each thermochromic cell may have a different thermochromic formulation, such that each cell has a different thermochromic signature or thermochromic transition characteristics. As an example, each of the plurality of thermochromic cells may be adapted to display a different numeral, and the plurality of thermochromic cells can be formulated to undergo a thermochromic transition, e.g., from colored to colorless, at the temperature corresponding to the numeral(s) which it displays. Thus, when the thermochromic composition becomes colorless, the numeral underlying the thermochromic composition becomes readily visible to an operator of the device, thereby indicating the temperature corresponding to the

numeric value. In alternative embodiments, alpha-numeric characters may be used to signify a particular temperature or temperature range, as opposed to showing actual temperature values. For example, the numerals I-V (or the letters A-E) could be used to signify five different temperatures or temperature ranges, e.g., numerals I, II, and III could correspond to 45°C, 50°C, and 55°C, respectively.

[0088] Fig. 9C also shows a plan view of the distal or working end of an device, the device including a temperature indicating element **950**" disposed at shaft distal end portion **902a**. Temperature indicating element **950**" includes a message unit **956** and is adapted to display one or more alpha-numeric characters, or a message, when a defined temperature condition applies. For example, according to one embodiment a message may be imprinted on message unit **956** in a thermochromic material (e.g., a thermochromic ink or thermochromic paint), wherein the thermochromic material is formulated to undergo a color change (e.g., from brown to green) at a pre-defined temperature. Alternatively, a text message imprinted on an underlying medium may be overlaid with a layer of thermochromic material formulated to undergo a thermochromic transition from colored/opaque to colorless/translucent at a defined temperature, whereby the underlying text message becomes visible through the thermochromic layer at the defined temperature.

[0089] In one embodiment, a message displayed by indicating element **950**" may be a text message, e.g., for warning an operator of the device that sufficient heat had been generated at the working end of the device for treatment of the tissue. To cite just a few examples, following a thermochromic transition, element **950**" may be adapted to display one or more of the following messages "REDUCE POWER," "REMOVE PROBE," or "END!". As an example of how element **950**" may be useful in practice, consider a procedure for electrosurgically shrinking collagen containing tissue (for which a temperature in the range of 60°C to 70°C may be desired). Element **950**" may be adapted, formulated, and configured to reveal one or more text messages, e.g., when exposed to a temperature below 60°C, and/or in excess of 65°C. Apparatus and procedures for shrinking collagen-containing tissue are described in commonly assigned US Patent Nos. 6,309,387 and 6,277,112.

[0090] Fig. 10 is a side view schematically representing a distal or working end of an electrosurgical device **1001**, according to another embodiment the invention. Device **1001** includes a shaft **1002** having a shaft distal end portion **1002a**. Device 1001 further includes an electrically insulating electrode support or spacer **1014**, at least one active electrode **1012** disposed on support **1014**, and a return electrode **1016** spaced proximally from active electrode **1012**.

[0091] Device **1001** still further includes a temperature-indicating element **1050** on shaft distal end portion **1002a**. Temperature-indicating element **1050** is in the form of a thermochromic annular band, which may com-

prise, for example, a plastic or a rubber having a thermochromic composition incorporated therein. The annular band and the thermochromic composition may be formulated and configured to undergo a distinct change in appearance, due to a thermochromic transition, upon exposure to a pre-selected temperature.

[0092] Temperature-indicating element **1050** may be encased within a sheath (e.g., Fig. 7) and/or may be disposed on a temperature indicator base (e.g., Fig. 8). Furthermore, temperature indicating element **1050** may be delineated or divided into a plurality of distinct thermochromic cells (e.g., Fig. 9A), and may be adapted to display one or more alpha-numeric characters in response to a defined temperature (e.g., Figs. 9B-C). Although element **1050** is shown in Fig. 10 as being located distal to return electrode **1016** and proximal to spacer **1014**, other configurations are also within the scope of the invention (see, e.g., Figs. 6A-F).

[0093] Figs. 11A-C schematically represent use of a device in a surgical procedure during which a temperature indicating element of the device undergoes a visual change. Fig. 11A schematically represents an electrosurgical device or probe 1101 including a shaft **1102** having a shaft distal end portion **1102a**. Shaft distal end portion **1102a** is positioned with respect to a target tissue, TT to be treated. Probe **1101** further includes a temperature indicating element **1150** disposed at shaft distal end portion **1102a**. Temperature indicating element **1150** typically includes a thermochromic material, and is adapted to undergo a readily discernible change in appearance in order to indicate a temperature condition to a user of probe **1101**. Typically, element **1150** is configured to be readily visible to the surgeon during use of probe **1101**, e.g., when viewed from a location indicated by the eye, EY of the surgeon.

[0094] Temperature indicating element **1150** may include various elements, features, and characteristics as described hereinabove for temperature indicating elements according to various embodiments of the invention (e.g., with reference to Figs. 6A-10). Similarly, probe **1101** may include various elements, features, and characteristics as described hereinabove for various devices according to other embodiments of the invention (e.g., with reference to Figs. 1-10). Thus, probe **1101** typically includes at least one active electrode or electrode terminal adapted for applying energy to the target tissue to be treated. Electrodes are omitted from Figs. 11A-C for the sake of clarity.

[0095] Probe **1101** is coupled to an electrosurgical generator or power supply 1128 via a cable 1160. Typically, power supply **1128** is adapted for supplying a RF, alternating-current voltage (ac voltage) to the target tissue via probe **1101**. During application of energy to the target tissue, shaft distal end portion **1102a** is positioned adjacent to, or in contact with, the target tissue. As shown, a remote control unit or switch **1190** may be coupled to power supply **1128**. As an example, unit **1190** may comprise one or more foot pedals for controlling power output

from power supply **1128**. An electrosurgical apparatus having foot pedal controls is described fully in commonly assigned US Patent No. 6,264,650 (Atty. Ref. No. S-5).

**[0096]** Figs. 11B and 11C show enlarged views of the distal end of probe **1101** at time  $T_1$  and time  $T_2$ , respectively. Time  $T_1$  represents a stage in the procedure before the working end of probe **1101** has been heated to an initial activation temperature for the respective temperature indicating element **1150**. It can be observed that at time  $T_1$  element **1150** has a first appearance. As an example only, element **1150** may comprise a liquid crystal exhibiting a brown color at time  $T_1$ .

**[0097]** With reference to Fig. 11C, time  $T_2$  represents a stage where the working end of probe **1101** has attained a particular pre-defined temperature, as indicated by element **1150** adopting a second appearance, wherein the second appearance is readily discernible from the first appearance. For example, the second appearance may signify that a desired target temperature for the procedure has been attained. As an example, the second appearance may be a green color indicative of a temperature in the middle of the thermochromic liquid crystal bandwidth. Thus, the change in appearance of element **1150** at time  $T_2$  may signal the surgeon that the application of energy to the target tissue may be discontinued, and the procedure can be brought to a satisfactory conclusion. Such changes in appearance of element **1150** in response to change in temperature may be obtained by suitable formulation of a thermochromic composition as a component of element **1150**, as described hereinabove.

**[0098]** According to an alternative aspect of the invention, a change in appearance of element **1150** at time  $T_2$  may inform the surgeon of the heat adjacent to the procedure and to adjust the level of power supplied to device **1101** from power supply **1128**. It should be noted that the temperature indicating element may give a dynamic visual indication of temperature at a location adjacent to the device. Once the surgeon stops treatment or the site cools, the temperature indicating element will revert to its natural state (e.g., a clear color.)

**[0099]** Fig. 12 is a block diagram schematically representing an endoscopic electrosurgical system **1200**, according to another embodiment of the invention. System **1200** typically includes an endoscope **1280**; an device **1201**, which may be adapted for use in conjunction with endoscope **1280**; a power supply **1228** for supplying power to device **1201**; as well as a camera **1282** and a monitor **1284** adapted for viewing a working end of device **1201** and the surgical site. Device **1201** typically comprises an electrosurgical catheter or an electrosurgical probe having an electrode assembly disposed at the working end of the device (e.g., as described hereinabove). The electrode assembly is adapted to apply electrical energy to a target tissue during a procedure.

**[0100]** Device **1201** is adapted for providing a visual indication to the surgeon, via camera **1282** and monitor **1284**, of a temperature condition of the working end of

the device. Accordingly, device **1201** includes a temperature-indicating element **1250** adapted to undergo a change in appearance in response to one or more pre-defined temperature conditions. As shown, temperature-indicating element **1250** includes a thermochromic unit **1252** having a thermochromic composition incorporated therein. Thermochromic compositions are well known in the art, and can be tailored or formulated, e.g., by chemical modification, such that one or more thermochromic transitions of the composition occur at defined temperature values. Typically, temperature-indicating element **1250** is disposed at the distal or working end of device **1201**, at a location that is readily visualized by the surgeon via camera **1282** and monitor **1284**. By observing the working end of device **1201**, the surgeon can monitor a temperature condition adjacent to the target tissue. For example, power supplied from power supply **1228** to device **1201** can be adjusted according to the appearance of temperature indicating element **1250**. Alternatively, if element **1250** indicates that a desired target temperature for the procedure has been achieved, treatment may be discontinued, thereby reducing the risk of thermal damage to underlying or adjacent, non-target tissue.

**[0101]** Fig. 13 schematically represents an arthroscopic procedure being performed on a patient's knee joint, KN using an electrosurgical system **1300**, according to another embodiment of the invention. System **1300** includes an arthroscope **1380**, a camera **1382**, and a monitor **1384**. A device (largely concealed by arthroscope **1380** in Fig. 13) includes a shaft distal end portion **1302a** located at the working end of the device. Typically, the device includes an electrode assembly disposed at shaft distal end portion **1302a**, wherein the electrode assembly includes at least one active electrode, disposed on an electrically insulating spacer, and a return electrode. (The electrode assembly is not shown in Fig. 13 for the sake of clarity.) The device is coupled to a power supply **1328** via a connector cable **1360**. Power supply **1328** is adapted for applying a high frequency voltage to the electrode assembly.

**[0102]** Again with reference to Fig. 13, temperature-indicating element **1350** is disposed at shaft distal end portion **1302a**. Typically, element **1350** comprises a thermochromic composition, and is adapted to provide a visual indication to the surgeon of one or more temperature conditions at the working end of the device by undergoing at least one pre-defined thermochromic transition. The visual indication provided to the surgeon may indicate the progress (e.g., completion) of a procedure, and reduces the risk of an excessively high temperature condition at the surgical site. Accordingly, thermal damage to adjacent or underlying, non-target tissue may be avoided. For greater clarity, temperature-indicating element **1350** is depicted on the monitor image of Fig. 13. Temperature-indicating element **1350** may include various elements, features, and characteristics of temperature indicating elements described herein with reference to other embodiments of the invention.

**[0103]** In an alternative embodiment, an electrosurgical device may be introduced to a joint cavity or other target site (e.g., percutaneously), and an arthroscope (or other endoscope) may be separately introduced to the surgical site to allow visualization of the target site and the temperature indicating element via a video monitor.

**[0104]** Although Fig. 13 shows a procedure on a knee joint, the invention is also applicable to a broad range of open and endoscopic procedures on various tissues and organs, as described hereinabove.

**[0105]** Figure 14 illustrates a perspective view of a tissue treatment member or head 910 of the present invention having a temperature indicator 930. Tissue treatment member 910 has a generally annular or loop configuration.

**[0106]** Tissue treatment member 910 includes an electrode support 904 extending from and connected to the distal end of shaft 902 of probe 900. Additionally, a base 916 may separate and further affix the support 904 to shaft 902. Support 904 supports an active electrode 906 and a return electrode 908 in a spaced apart relationship. The support may be made of an electrically non-conducting material such as, for example, ceramic or a plastic. In the illustrated embodiment, active electrode 906 has ends 906a extending into and through openings in support structure 904 to a power supply via one or more conducting members (not shown). Return electrode 908 is operatively connected to the power supply via one or more conducting members (not shown).

**[0107]** Support 904 has an annular or circular configuration and a cavity or recess 914 within a tissue contacting surface 912 for holding active electrode 906. Preferably, active electrode 906 has a shape and configuration that allows it to cooperatively fit within recess 914. While the illustrated embodiment provides a support 904 and active electrode 906 as an annular, loop, ring or circular configuration, their respective shapes and that of recess 914 may vary widely, e.g., serpentine, rectangular, oblong, etc. Additionally, more than one cavity may be provided in the support wherein each cavity may support one or more electrodes. Active electrode 906 may be spaced a predetermined distance from the target tissue by properly pre-selecting the depth of the cavity 914 and the size, diameter or thickness of the electrode. Preferably, active electrode 906 is positioned such that a portion of its surface is flush with or just below the tissue-contacting surface 912 of support 904. In the particular variation illustrated, cavity 914 is provided at a depth on the inside top surface of support 904 and active electrode 906 has a diameter and a thickness such that, when active electrode 906 is operatively provided within cavity 914, tissue contacting surface 912 is substantially flush and smooth (or, as stated above, the active electrode may be positioned below or recessed within cavity 914). In addition to operative advantages, such a configuration serves to protect active electrode 906 from damage during surgery. Other variations are contemplated, for example, where cavity 914 and thus active electrode 906

seated therein are provided at a depth on the outer, top surface of support 904 or on a lateral or perimeter surface of support 904.

**[0108]** As shown the probe 900 may also include a temperature indicator 930. Temperature indicator 930 may be as described above. It may have a band shape that extends circumferentially about the support 904. The band may be positioned within an annular gap such that the temperature indicator is flush with the electrode support tissue treatment surface. The temperature indicator may be divided into one or more discrete components or it may be continuous as shown.

**[0109]** Return electrode 908 is provided about the perimeter, circumference or outer surface of support 904 such that support 904 is partially positioned or extends between active electrode 906 and return electrode 908. Similarly, return electrode 908 has a shape and configuration that allows it to fit about support 904. Such a support and electrode configuration provides structural robustness to both electrodes. While return electrode 906 has a clip or loop configuration in the illustrated embodiment, it may have any suitable configuration and position with respect to support 904 and active electrode 906. As shown return electrode 906 surrounds the body of the support 904 such that it is concentric with support 904 and active electrode 906, but has a width or height dimension which is less than that of support 904 such that return electrode 906 does not cover either the active (upper) or inactive (lower) portions of support 904. Accordingly, when treating tissue in a narrow space such that both the active and inactive sides of support 904 contact tissue, tissue at only the active side is ablated because the plasma generated as a result of the application of high frequency voltage via active electrode 906 does not extend to the lower side of support 904.

**[0110]** Electrodes 906 and 908 may be made of any of the electrode materials previously mentioned. Preferably, active electrode 906 is made of a material of that which undergoes minimal oxidation and has a low electrical resistivity, e.g., tungsten or tantalum. Such materials result in an ablated tissue surface that is minimally discolored and has minimal thermal damage. Examples of materials which may be used for return electrode 908 are stainless steel, copper and alloys thereof. Optional additional features of support 904 include one or more cut-out or recessed regions 917. According to the invention the support 904 includes one or more openings or apertures 918. More particularly, the tissue-contacting surface 912 is recessed in one or more locations 917 to facilitate fluid flow within cavity 914 and contact with active electrode 906. While the illustrated embodiment provides recessed regions 917 about the circumference of annular active electrode 906 that extend the thickness of support 904, such recessed regions may be located internally to the electrode's annulus or within the boundary of the electrode loop. Aperture 918 further facilitates fluid circulation about active electrode 906 to increase conductivity in the contacted tissue area. Additionally,

opening 918 acts as a vent to prevent heat from accumulating adjacent to the tissue treatment surface as well as allows air or gas bubbles that are formed during ablation to escape from the tissue treatment zone. While only a single opening 918 positioned concentrically within the electrode loop is illustrated, multiple openings may be provided in any suitable pattern within the space defined by active electrode 906 or outside the perimeter or both.

[0111] While the exemplary embodiments of the present invention have been described in detail, by way of example and for clarity of understanding, a variety of changes, adaptations, and modifications will be apparent to those of skill in the art. In addition, it is to be understood that certain elements or features of various disclosed embodiments may be substituted for corresponding or analogous elements or features of other disclosed embodiments, or may be combined with elements and features of other disclosed embodiments, without departing from the scope of the instant invention. Therefore, the scope of the present invention is limited solely by the appended claims.

#### Claims

1. An electrosurgical instrument for applying electrical energy to tissue at a target site, the instrument comprising: a shaft (902), a proximal end and a distal end; a non-electrically conducting support (904) disposed at the distal end extending from and connected to the shaft (902), said support having a tissue-contacting surface (912) having a cavity (914) therein; a temperature indicator (930) positioned on said support; an annular active electrode positioned within the cavity (914); and a return electrode positioned about an outer surface of said support to surround but not cover the support such that the support extends between the active electrode (906) and the return electrode (908), wherein the support (904) comprises an aperture (918) to facilitate flow of a conductive fluid around the active electrode (906) and to allow gas to escape from the target site.
2. The electrosurgical instrument of claim 1 in which the support (904) and/or the recess (914) has a configuration selected from the list comprising: annular, loop, ring, circular, serpentine and oblong.
3. The electrosurgical instrument of claim 1 or 2 in which the active electrode (906) is configured to cooperatively fit within the recess (914).
4. The electrosurgical instrument of any preceding claim in which the active electrode (906) is arranged to be spaced a predetermined distance from the target tissue by pre-selecting the depth of the cavity (914) and the size, diameter or thickness of the active

electrode (906).

5. The electrosurgical instrument of claim 4 in which the active electrode (906) is positioned such that a portion of its surface is flush with or just below the tissue-contacting surface (912) of support (904).
6. The electrosurgical instrument of any preceding claim in which the temperature indicator (930) has a band shape that extends circumferentially about the support (904).
7. The electrosurgical instrument of claim 6 in which the temperature indicator (930) is positioned within an annular gap such that the temperature indicator is flush with the tissue-contacting surface (912) of support (904).
8. The electrosurgical instrument of claim 6 or 7 in which the temperature indicator (930) is divided into one or more discrete components.
9. The electrosurgical instrument of claim 6 or 7 in which the temperature indicator (930) is continuous.
10. The electrosurgical instrument of any preceding claim in which the return electrode (908) has a configuration that allows it to fit about the support (904).
11. The electrosurgical instrument of claim 10 in which the return electrode (908) has a clip or loop configuration.
12. The electrosurgical instrument of any preceding claim in which the active electrode (906) comprises tungsten or tantalum.
13. The electrosurgical instrument of any preceding claim in which the return electrode (908) comprises stainless steel, copper and/or alloys thereof.

#### Patentansprüche

1. Elektrochirurgisches Instrument zum Anwenden von elektrischer Energie auf Gewebe an einem Zielsitus, wobei das Instrument Folgendes umfasst: einen Schaft (902), ein proximales Ende und ein distales Ende; einen nicht elektrisch leitenden Träger (904), der an dem distalen Ende angeordnet ist, das sich von dem Schaft (902) erstreckt und mit diesem verbunden ist, wobei der Träger eine Gewebekontaktfläche (912) aufweist, die darin eine Aussparung (914) aufweist; einen Temperaturanzeiger (930), der an dem Träger positioniert ist; eine kranzförmige aktive Elektrode, die innerhalb der Aussparung (914) angeordnet ist; und eine Gegenelektrode, die um eine Außenfläche des Trägers positioniert ist, um den

- Träger zu umgeben, jedoch nicht abzudecken, so dass der Träger sich zwischen der aktiven Elektrode (906) und der Gegenelektrode (908) erstreckt, wobei der Träger (904) eine Öffnung (918) umfasst, um das Strömen eines leitfähigen Fluids um die aktive Elektrode (906) zu erleichtern und Gas von dem Ziel-situs entweichen zu lassen.
2. Elektrochirurgisches Instrument nach Anspruch 1, wobei der Träger (904) und/oder die Vertiefung (914) eine Konfiguration aufweisen, die aus der Liste ausgewählt ist, die Folgendes umfasst: kranzförmig, Schlaufe, Ring, kreisförmig, schlangenförmig und länglich.
  3. Elektrochirurgisches Instrument nach Anspruch 1 oder 2, wobei die aktive Elektrode (906) dazu konfiguriert ist, zusammenwirkend in die Vertiefung (914) zu passen.
  4. Elektrochirurgisches Instrument nach einem vorhergehenden Anspruch, wobei die aktive Elektrode (906) dazu angeordnet ist, durch vorheriges Auswählen der Tiefe der Aussparung (914) und der Größe, des Durchmessers oder der Dicke der aktiven Elektrode (906) in einem vorher festgelegten Abstand von dem Zielgewebe beabstandet zu sein.
  5. Elektrochirurgisches Instrument nach Anspruch 4, wobei die aktive Elektrode (906) positioniert ist, so dass ein Abschnitt ihrer Fläche mit der Gewebekontaktfläche (912) des Trägers (904) bündig ist oder unmittelbar unterhalb dieser ist.
  6. Elektrochirurgisches Instrument nach einem vorhergehenden Anspruch, wobei der Temperaturanzeiger (930) eine Bandform aufweist, die sich umlaufend um den Träger (904) erstreckt.
  7. Elektrochirurgisches Instrument nach Anspruch 6, wobei der Temperaturanzeiger (930) innerhalb eines kreisförmigen Spalts positioniert ist, so dass der Temperaturanzeiger mit der Gewebekontaktfläche (912) des Trägers (904) bündig ist.
  8. Elektrochirurgisches Instrument nach Anspruch 6 oder 7, wobei der Temperaturanzeiger (930) in eine oder mehrere separate Komponenten unterteilt ist.
  9. Elektrochirurgisches Instrument nach Anspruch 6 oder 7, wobei der Temperaturanzeiger (930) durchgehend ist.
  10. Elektrochirurgisches Instrument nach einem vorhergehenden Anspruch, wobei die Gegenelektrode (908) eine Konfiguration aufweist, die ihr ermöglicht, um den Träger (904) zu passen.
  11. Elektrochirurgisches Instrument nach Anspruch 10, wobei die Gegenelektrode (908) eine Schellen- oder Schlaufenkonfiguration aufweist.
  12. Elektrochirurgisches Instrument nach einem vorhergehenden Anspruch, wobei die aktive Elektrode (906) Wolfram oder Tantal umfasst.
  13. Elektrochirurgisches Instrument nach einem vorhergehenden Anspruch, wobei die Gegenelektrode (908) Edelstahl, Kupfer und/oder Legierungen davon umfasst.
- 15 Revendications**
1. Instrument électrochirurgical pour appliquer de l'énergie électrique au tissu au niveau d'un site cible, l'instrument comprenant : une tige (902), une extrémité proximale et une extrémité distale ; un support non conducteur électriquement (904) disposé au niveau de l'extrémité distale et s'étendant depuis la tige (902) et étant connecté à la tige (902), ledit support ayant une surface de contact avec le tissu (912) ayant une cavité (914) dans celle-ci ; un indicateur de température (930) positionné sur ledit support ; une électrode active annulaire positionnée au sein de la cavité (914) ; et une électrode de retour positionnée autour d'une surface externe dudit support pour entourer le support mais sans le recouvrir de sorte que le support s'étend entre l'électrode active (906) et l'électrode de retour (908), dans lequel le support (904) comprend une ouverture (918) pour faciliter l'écoulement d'un fluide conducteur autour de l'électrode active (906) et pour permettre au gaz de s'échapper du site cible.
  2. Élément électrochirurgical selon la revendication 1 dans lequel le support (904) et/ou le renforcement (914) a une configuration sélectionnée dans la liste comprenant : annulaire, en boucle, en couronne, circulaire, sinueuse et oblongue.
  3. Élément électrochirurgical selon la revendication 1 ou 2 dans lequel l'électrode active (906) est configurée pour s'ajuster de manière coopérative au sein du renforcement (914) .
  4. Élément électrochirurgical selon l'une quelconque des revendications précédentes dans lequel l'électrode active (906) est agencée pour être espacée, par une distance prédéterminée, du tissu cible en présélectionnant la profondeur de la cavité (914) et la taille, le diamètre ou l'épaisseur de l'électrode active (906).
  5. Élément électrochirurgical selon la revendication 4 dans lequel l'électrode active (906) est positionnée

de sorte qu'une partie de sa surface est au ras ou juste au-dessous de la surface de contact avec le tissu (912) du support (904).

6. Élément électrochirurgical selon l'une quelconque des revendications précédentes dans lequel l'indicateur de température (930) a une forme de bande qui s'étend de manière circonférentielle autour du support (904). 5
7. Élément électrochirurgical selon la revendication 6 dans lequel l'indicateur de température (930) est positionné au sein d'un espace annulaire de sorte que l'indicateur de température est au ras de la surface de contact avec le tissu (912) du support (904). 10
8. Élément électrochirurgical selon la revendication 6 ou 7 dans lequel l'indicateur de température (930) est divisé en un ou plusieurs composants discrets. 15
9. Élément électrochirurgical selon la revendication 6 ou 7 dans lequel l'indicateur de température (930) est continu. 20
10. Élément électrochirurgical selon l'une quelconque des revendications précédentes dans lequel l'électrode de retour (908) a une configuration qui lui permet d'être ajustée autour du support (904). 25
11. Élément électrochirurgical selon la revendication 10 dans lequel l'électrode de retour (908) a une configuration en agrafe ou en boucle. 30
12. Élément électrochirurgical selon l'une quelconque des revendications précédentes dans lequel l'électrode active (906) comprend du tungstène ou du tantale. 35
13. Élément électrochirurgical selon l'une quelconque des revendications précédentes dans lequel l'électrode de retour (908) comprend de l'acier inoxydable, du cuivre et/ou des alliages de ceux-ci. 40

45

50

55

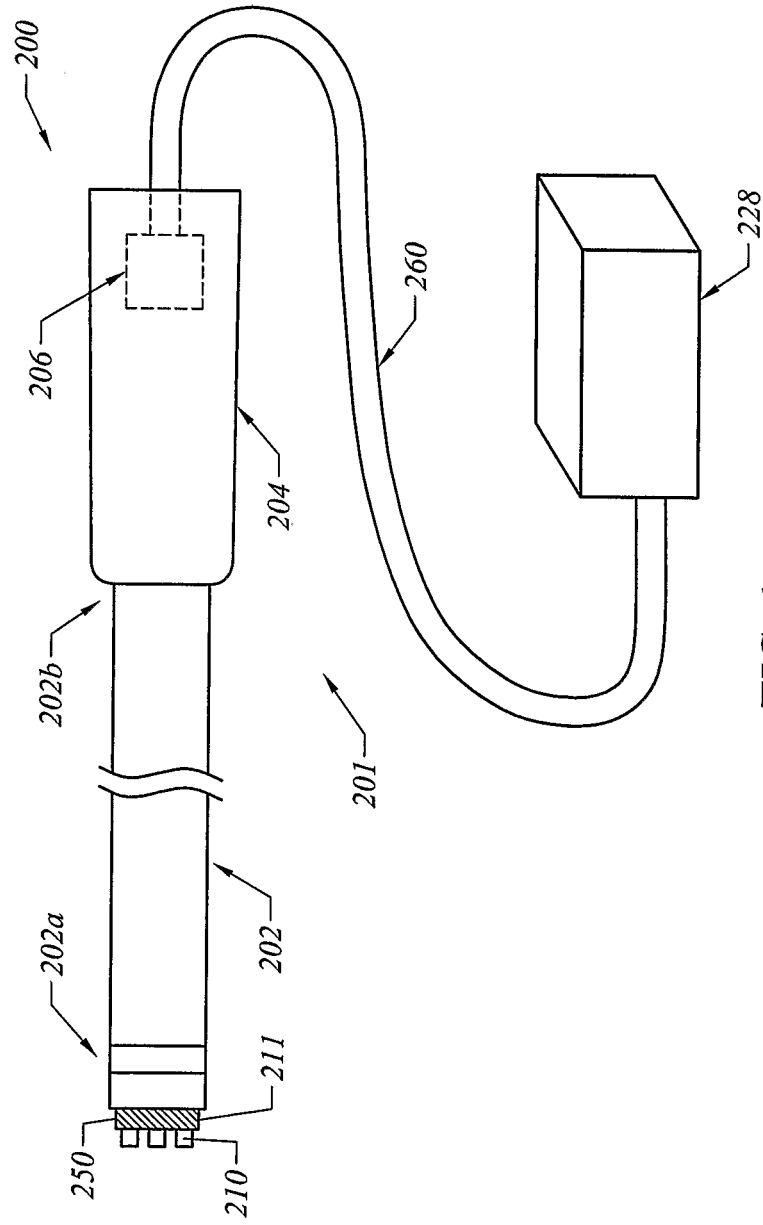

FIG. 1



FIG. 2A

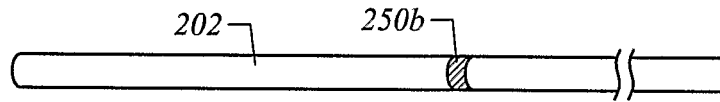

FIG. 2B

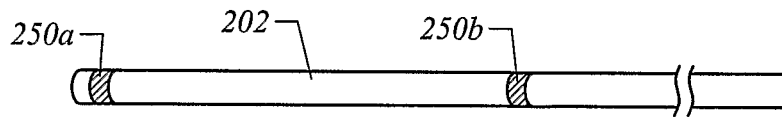

FIG. 2C

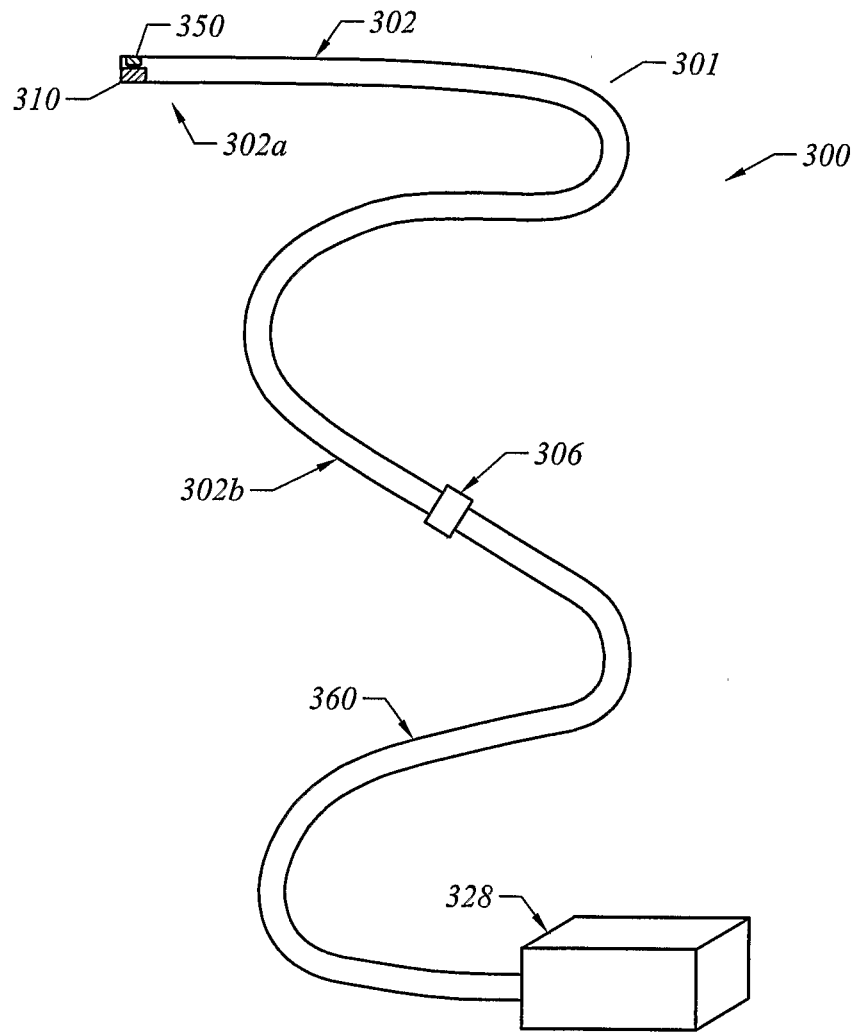

FIG. 3

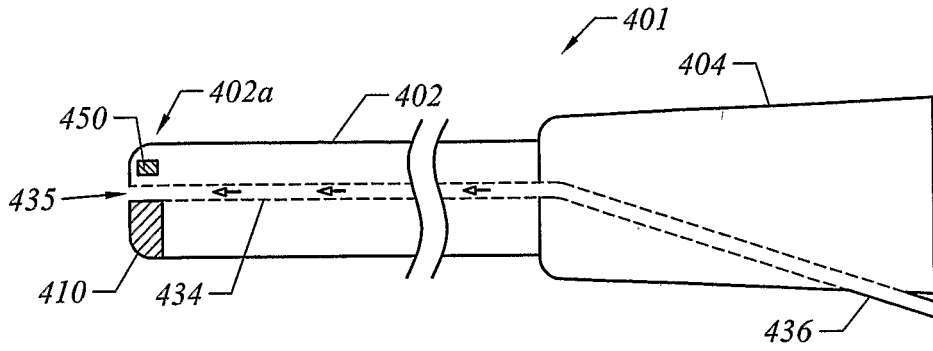

FIG. 4A

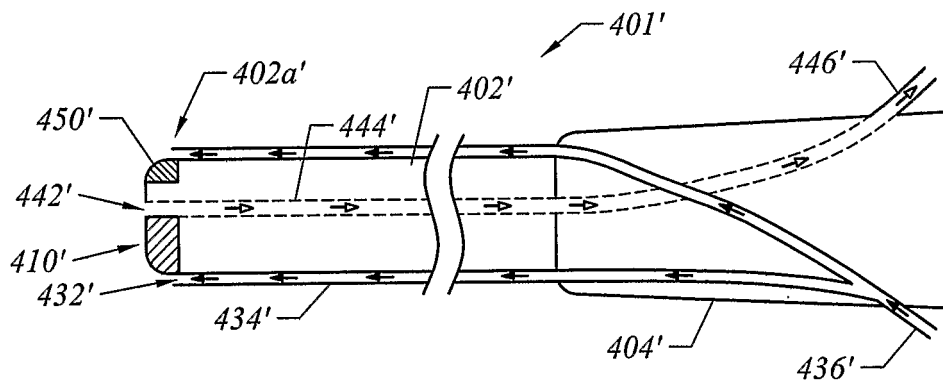
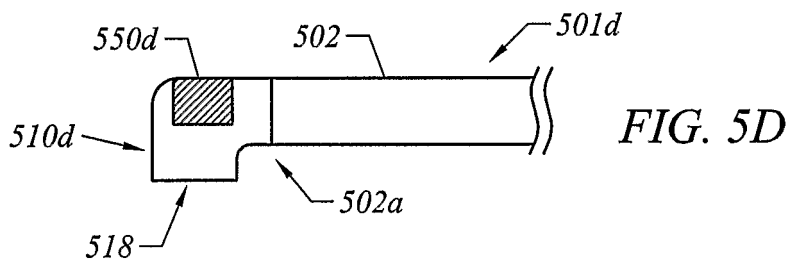
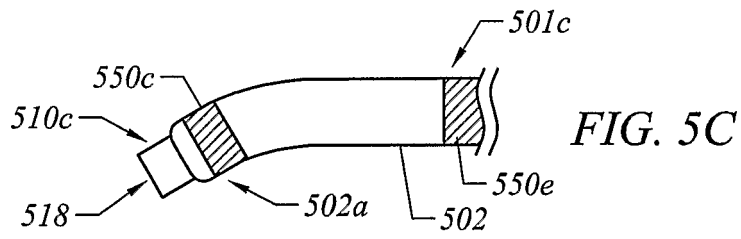
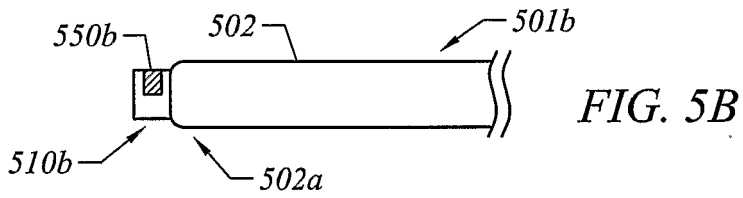
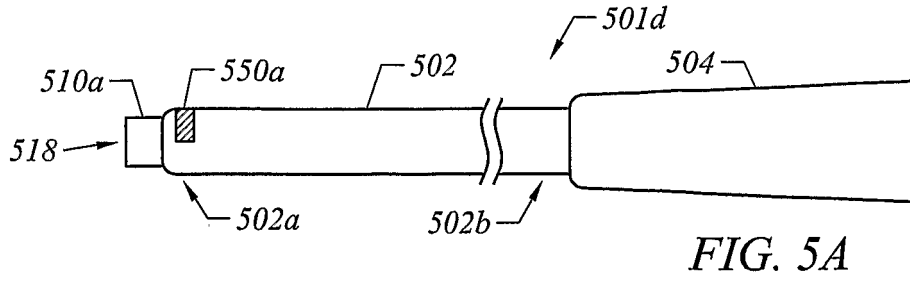

FIG. 4B



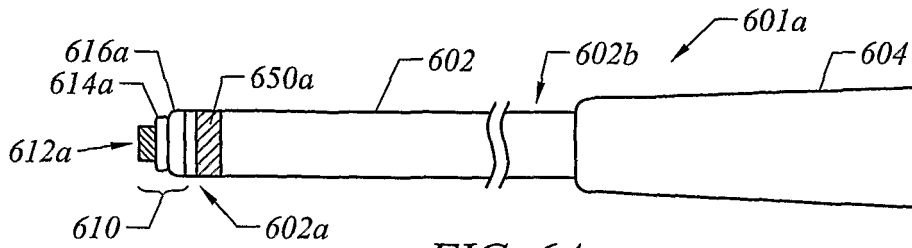

FIG. 6A

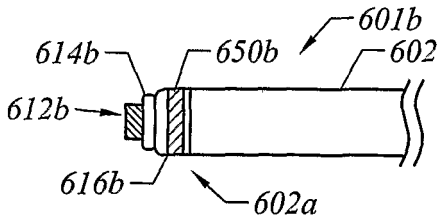

FIG. 6B

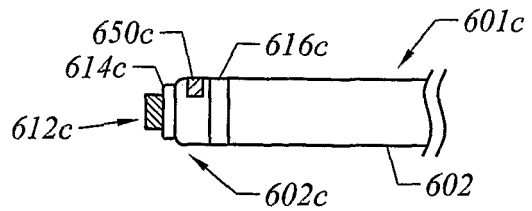

FIG. 6C

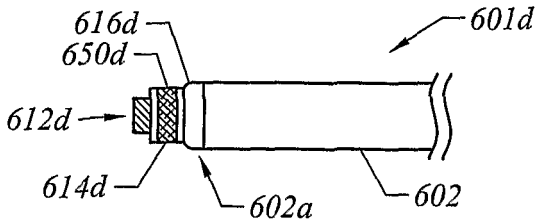

FIG. 6D

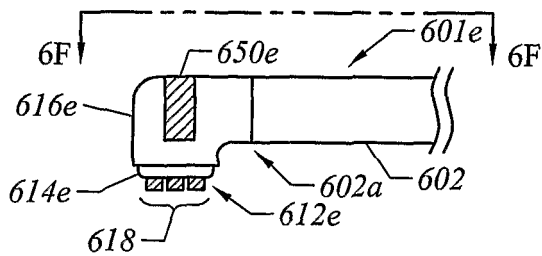

FIG. 6E

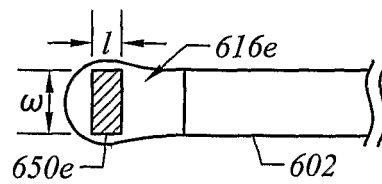

FIG. 6F

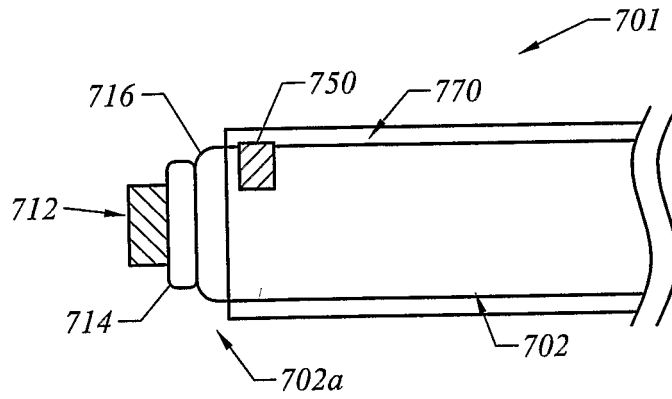

FIG. 7

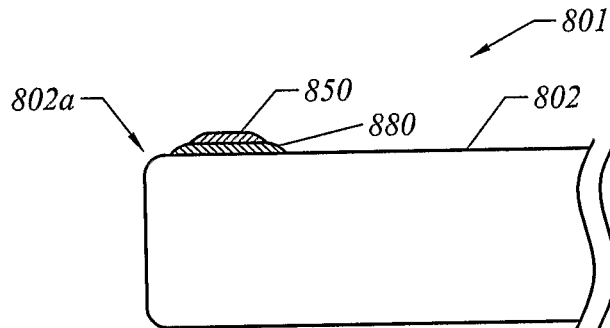

FIG. 8

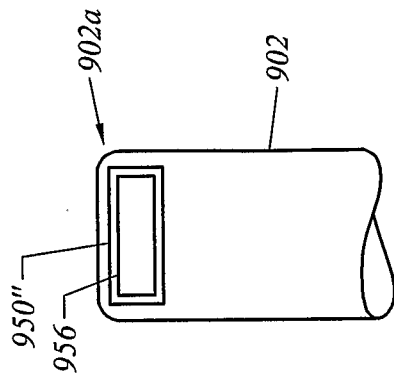

FIG. 9C

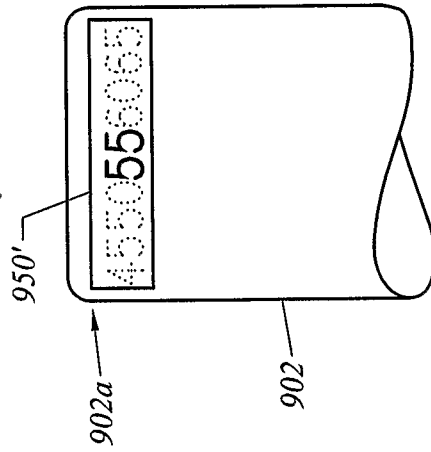

FIG. 9B

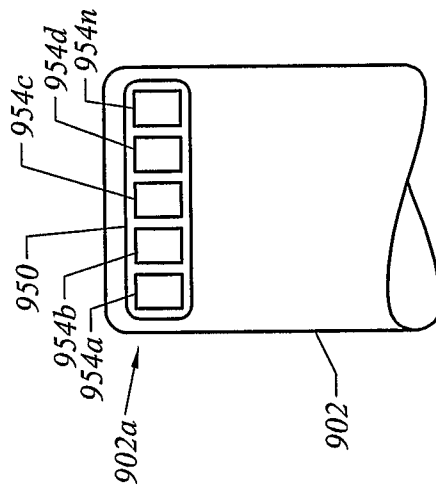

FIG. 9A

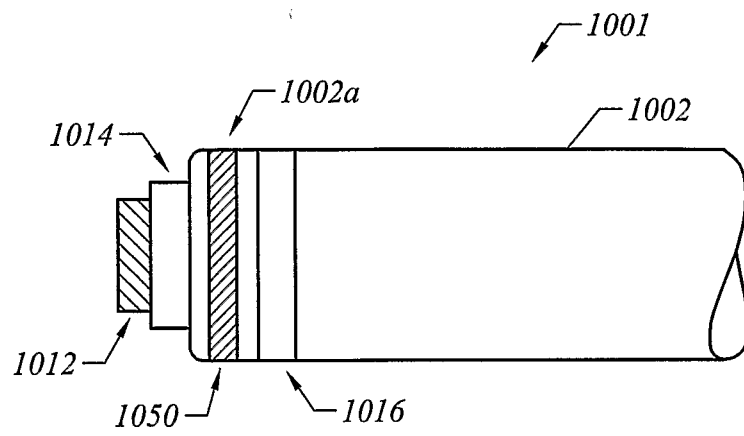

FIG. 10

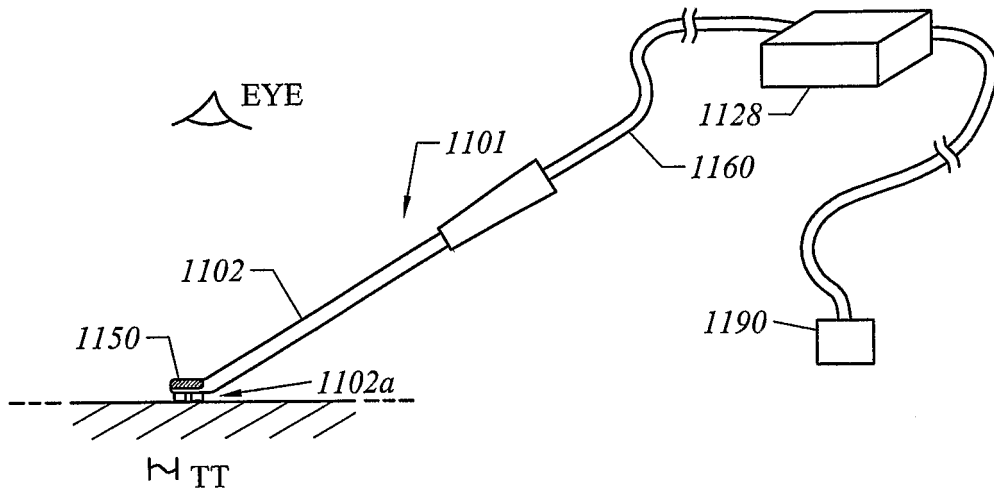

FIG. 11A

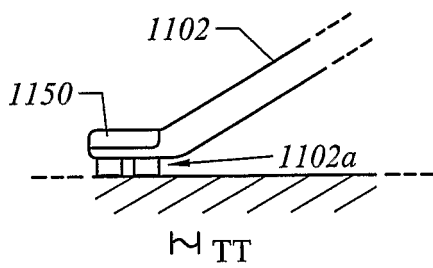

FIG. 11B

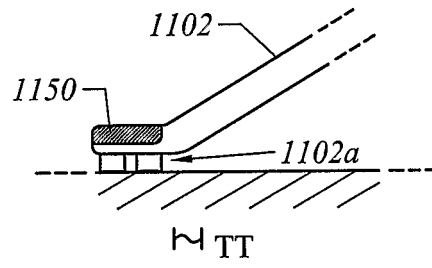

FIG. 11C

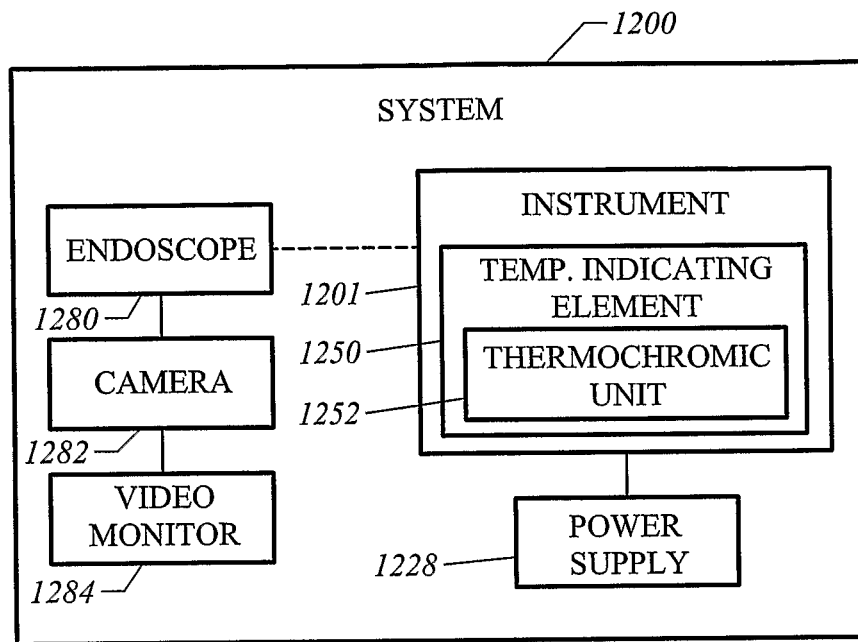

FIG. 12

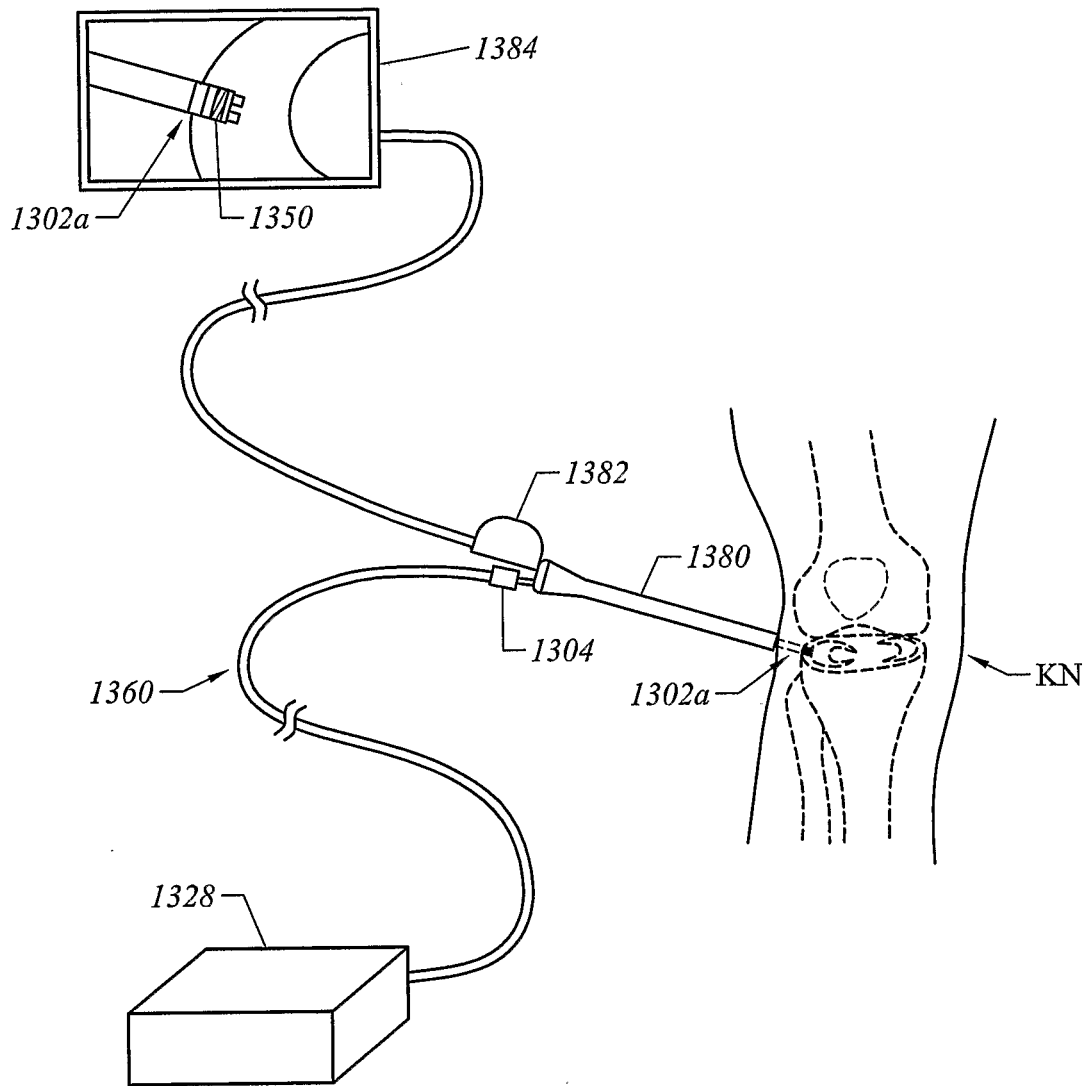

FIG. 13

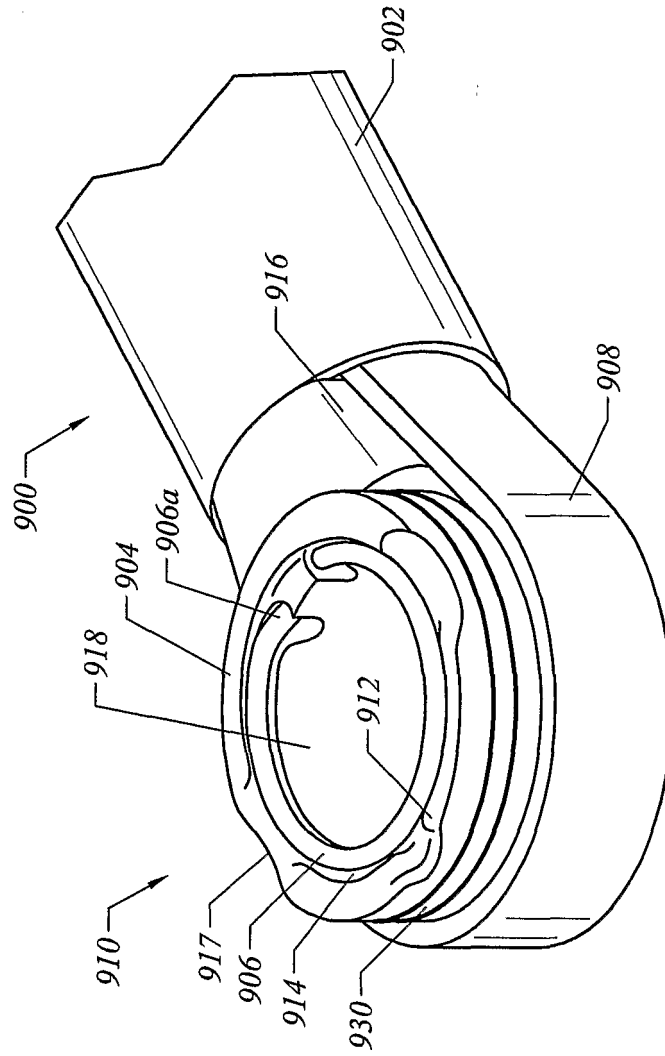

FIG. 14

**REFERENCES CITED IN THE DESCRIPTION**

*This list of references cited by the applicant is for the reader's convenience only. It does not form part of the European patent document. Even though great care has been taken in compiling the references, errors or omissions cannot be excluded and the EPO disclaims all liability in this regard.*

**Patent documents cited in the description**

- US 6293943 B [0006]
- US 6197021 B, Panescu [0006]
- US 5599350 A [0008]
- US 6174309 B [0009]
- US 6514250 B [0010]
- GB 2333455 A [0011]
- WO 0062685 A [0011]
- US 20020107516 A [0011]
- WO 9917690 A [0011]
- US 5697882 A [0023]
- US 6355032 B [0025]
- US 6149120 A [0025]
- US 6296136 B [0025]
- US 6312408 B [0030] [0034]
- US 6235020 B [0031]
- US 6142992 A [0033]
- US 6149620 A [0034] [0056]
- US 5697281 A [0034]
- US 6238391 B [0035] [0058]
- US 6254600 B [0035]
- US 6296638 B [0037] [0066] [0073]
- US 6066134 A [0057]
- US 6309387 B [0089]
- US 6277112 B [0089]
- US 6264650 B [0095]

**Non-patent literature cited in the description**

- **R.J. GOLDSTON ; P.H. RUTHERFORD.** Plasma Physics. Plasma Physics Laboratory of Princeton University, 1995 [0021]
- Encyclopedia of Chemical Technology. John Wiley & Sons, Inc, [0044]
- **D.J. FARINO.** *Making Surface Temperature Measurements Using Liquid Crystal Thermography*, [http://www.electronics-cooling.com/Resources/EC\\_Articles/OCT95/oct95\\_01.htm](http://www.electronics-cooling.com/Resources/EC_Articles/OCT95/oct95_01.htm) [0048]

专利名称(译)	温度指示电外科设备和方法		
公开(公告)号	<a href="#">EP1596705A2</a>	公开(公告)日	2005-11-23
申请号	EP2004708664	申请日	2004-02-05
[标]申请(专利权)人(译)	亚瑟罗凯尔公司		
申请(专利权)人(译)	ARTHROCARE CORPORATION		
当前申请(专利权)人(译)	ARTHROCARE CORPORATION		
[标]发明人	WOLOSZKO JEAN DAHLA ROBERT H BAKER MICHAEL A PACEK JAMES L		
发明人	WOLOSZKO, JEAN DAHLA, ROBERT, H. BAKER, MICHAEL, A. PACEK, JAMES, L.		
IPC分类号	A61B18/04 A61B A61B1/00 A61B5/00 A61B18/14 A61B18/18		
CPC分类号	A61B18/1492 A61B5/01 A61B5/015 A61B5/4528 A61B18/04 A61B18/042 A61B18/148 A61B18/18 A61B2018/00791 A61B2018/00809 A61B2562/0276		
代理机构(译)	WORK, 伊利亚		
优先权	60/445405 2003-02-05 US		
其他公开文献	EP1596705A4 EP1596705B1		
外部链接	<a href="#">Espacenet</a>		

#### 摘要(译)

用于在手术期间监测手术部位附近区域的温度的系统，装置和方法。电外科装置的温度指示元件包括指示剂组合物，其适于响应于预定温度范围而经历外观变化。温度指示元件的外观变化向装置的操作者指示装置工作端的温度条件。