

(19)



(11)

EP 1 215 994 B1

(12)

EUROPEAN PATENT SPECIFICATION

(45) Date of publication and mention of the grant of the patent:
25.07.2007 Bulletin 2007/30

(51) Int Cl.:
A61B 5/00 (2006.01)

(21) Application number: **00961948.7**

(86) International application number:
PCT/US2000/025426

(22) Date of filing: **15.09.2000**

(87) International publication number:
WO 2001/019239 (22.03.2001 Gazette 2001/12)

(54) SENSING, INTERROGATING, STORING, TELEMETERING AND RESPONDING MEDICAL IMPLANTS

MEDIZINISCHES IMPLANTAT ZUR FÜHLUNG, DATENSPEICHERUNG UND ZUR TELEMETRIE
IMPLANTS MEDICAUX PERMETTANT LA TELEMETRIE, LA REPONSE, LE STOCKAGE,
L'INTERROGATION ET LA DETECTION

(84) Designated Contracting States:
**AT BE CH CY DE DK ES FI FR GB GR IE IT LI LU
MC NL PT SE**

(72) Inventor: **SLEPIAN, Marvin, J.**
Tucson, AZ 85715 (US)

(30) Priority: **17.09.1999 US 154637 P**

(74) Representative: **Pilkington, Stephanie Joan et al**
Eric Potter Clarkson LLP
Park View House
58 The Ropewalk
Nottingham NG1 5DD (GB)

(43) Date of publication of application:
26.06.2002 Bulletin 2002/26

(60) Divisional application:
07000766.1

(56) References cited:
WO-A-91/01689 **WO-A-91/91680**
WO-A-92/21307 **WO-A-98/29030**
US-A- 4 364 385 **US-A- 5 056 530**
US-A- 5 544 651 **US-A- 5 769 893**
US-A- 5 833 603 **US-A- 5 833 623**
US-A- 5 938 607

(73) Proprietor: **ENDOLUMINAL THERAPEUTICS, INC.**
Tuscon, AZ 85715 (US)

EP 1 215 994 B1

Note: Within nine months from the publication of the mention of the grant of the European patent, any person may give notice to the European Patent Office of opposition to the European patent granted. Notice of opposition shall be filed in a written reasoned statement. It shall not be deemed to have been filed until the opposition fee has been paid. (Art. 99(1) European Patent Convention).

Description

Background of the Invention

[0001] This disclosure is generally in the area of implants which include sensors capable of detecting or interrogating physical, cellular, and other variables, including means for collecting, amplifying, storing and telemetering information as well as a feedback loop and means for modifying the implant after placement in a patient in response to measurements made using the sensors.

[0002] This application claims priority to U.S.S.N. 60/154,637 filed September 17, 1999.

[0003] Medical implants have been used for many years in interventional radiology, gastroenterology, urology and cardiology and other fields of medicine and surgery. In general, these devices are static and not interactive, i.e., they are implanted for a particular purpose and no change occurs, save for bystander corrosion or biodegradation, over time or for removal in the event a problem develops. Typically conventional implants are fashioned from medical grade stainless steel, compatible polymers, e.g. Dacron™ or Teflon™, or ceramics. More advanced implants have been developed using shape memory metals and polymers. Shape memory is the ability of a material to remember its original shape, either after mechanical deformation, or by cooling and heating. These materials have been proposed for various uses, including vascular implants, medical guidewires, orthodontic wires, etc.

[0004] Recently, in an attempt to move implants from being simple structural or augmentative, non-interactive devices, modifications have been made to include a sensor, for example, sensors for cardiac activity or sensors for monitoring blood flow. The sensors measure flow, pressure and/or strain. Most are not remotely "interrogatable", which is understood to mean that data cannot be extracted remotely, after implantation in a body. Some are remotely interactive, however. For example, particularly with the pacemaker patents, batteries can be recharged non-invasively. Some sensors are interactive at the site of implantation, but not remotely. Most require some type of "hard-wiring" to either program the device or to extract data. U.S. Patent No. 5,411,551 to Winston, et al., describes a stent that includes a sensor located on the inside of the expandable stent wall that is directly connected to a remote monitoring device. U.S. Patent No. 6,091,980 to Squire, et al., describes a stent including multiple conductive pads to generate a signal when the stent slips or moves from the original position.

[0005] An example of a stent which includes a remotely accessible sensor to assist in locating the stent is described in EP 0850654 by Schneider (USA) Inc. U.S. Patent No. 5,807,259 to Cimochowski, et al., U.S. Patent No. 6,053,873 to Govari, et al., and U.S. Patent No. 6,015,387 to Schwartz, et al. describe a device which is implantable to monitor flow and/or pressure in a vessel, graft or prosthetic. The '259 and '873 pressure sensors

include a radio coil for remote access of the data which is transmitted as ultrasonic waves by a transducer. The '387 sensor generates an electromagnetic, ultrasonic and/or radio frequency signal indicative of the rate of blood flow in the associated vessel. U.S. Patent No. 5,833,603 to Kovacs, et al. describes an implantable transponder including a sensor for temperature, strain, pressure, magnetism, acceleration, ionizing radiation, acoustic waves, or chemicals, where the sensor can be associated with an implanted prosthetic or graft. Data is transmitted to a remote reader.

U.S. Patent No. 5,709,225 to Budgifvars, et al., assigned to Pacesetter AB, describes a medical implant containing a magnetic field detector with a capacitive sensor detecting changes in the presence of a magnetic field, and means for generating a remotely-detectable signal, for use in determining an appropriate medical therapy. U.S. Patent No. 5,928,248 to Acker describes a stent including a system which transmits non-ionizing fields between a transducer or transducers on the probe and external transducers, to aid in positioning of the stent.

[0006] None of these devices, however, are responsive to the data which is collected by the sensors. None of these devices incorporates means of repeated or interval or programmed interrogation, via either intrinsic or extrinsic interrogative means. None of these devices incorporates within the device means for signal processing and interpretation. None of these devices includes means for raw or processed data storage. None of these devices has incorporated intrinsic or proximate means for change, i.e. alteration of the local environment or local or distant therapy as a result of gathered information. Further, none of these devices has the ability to telemeter and interact with data transmission or communication means which exist as single or multiple e.g. nested, loops of information transfer. Therefore it is an object of the present invention to provide devices and systems incorporating such devices, for implantation in a patient wherein the implant includes means for collection, and/or processing and/or storage of data.

[0007] It is another object of the present invention to provide devices and systems incorporating such devices, for implantation in a patient wherein the implanted device includes means for telemetry or communication of data for subsequent interaction with data transmission or communication means, in single or multiple such as "nested", loops of information transfer.

[0008] It is another object of the present invention to provide devices and systems incorporating such devices, for implantation in a patient wherein the implant includes means for responding, such as mounting of a therapeutic action, on the basis of either local data collected or external dependent or independent signals.

[0009] US-A-5544651 discloses a system comprising a sensor for measuring a predetermined physiological parameter of a patient, and generating a signal including a measured value of the physiological parameter.

[0010] A treatment component is operatively connect-

ed to a computer that compares the measured value with a predetermined threshold value, the treatment component being activated in the event of the measured value passing the threshold value.

[0011] The operative parts of the system of US-A-5544651 are stated to be implantable inside a patient, but when so configured they exist as discrete devices. US-A-5544651 does not describe any practical arrangements that genuinely render the system thereof suitable for implantation.

[0012] US-A-5833623 discloses a computer-based programmable device for interrogating an implanted pacemaker. The programmable device receives historical data from the pacemaker, during a diagnostic session of limited duration e.g. in a physician's office.

[0013] The apparatus of US-A-5833623 however cannot influence or control the pacemaker, operation of which must be adjusted by way of a separate procedure following evaluation of the historical data by a physician.

[0014] WO-A-92/21307 discloses an ingestible device that is capable of signalling, to outside a patient's body, its position in the alimentary canal.

[0015] The ingestible device of WO-A-92/21307 also is operable, following transmission of an activation signal, generated outside the body, to dispense a medicaments or other substances. It is however disclosed in WO-A-92/21307 that when the device is configured to signal its position it does not function to dispense medicament, and vice-versa. Thus it is necessary for a patient to swallow one of the devices for the purpose of "mapping" the alimentary canal, before subsequently swallowing another of the devices for the purpose of medicament dosing.

[0016] US-A-5769893 discloses an implantable device for inducing growth of soft tissues of a patient. A monitoring and control device may monitor and control the amount of growth.

[0017] The apparatus of US-A-5769893 cannot respond to the environment of the implanted device. On the contrary, human intervention is needed to initiate and terminate operation of the device, through the use of push buttons.

[0018] Self-evidently the push buttons of US-A-5759893 should only be operated by a physician. However, the sole embodiment of the push button system disclosed in US-A-5769893 is also operable by the patient. This represents a potentially hazardous mode of operation.

Summary of the Invention

[0019] The invention is as defined in appended claims 1 and 30.

[0020] Implantable devices (i.e. "implants"), including sensors for data measurement, and/or data analyzers, and/or data storage means, and/or data telemetry/transmission means including means for communication at multiple levels or isolated or nested levels of information transfer have been developed. These devices may have

incorporated means for modification of the implant or mounting a response, e.g. local or systemic drug delivery, in response to measurements made using the sensors. These are particularly useful in urology, hepatology or cardiology, where the implants contain one or more sensors responsive to variables which change over time, for example, pressure which is indicative of changes in fluid flow and diameter of the ureter, biliary duct or vessel in which the implant has been placed. Feedback from the sensor(s) either directly, or indirectly via monitoring means external to the patient, signal changes that may be required, such as expansion of the implant in the case where the tissue lumen diameter changes over time or the implant becomes unstable or migrates. In another embodiment, the implant contains a bioactive, prophylactic, diagnostic or pH modifying agent. In one embodiment, the implant is formed of a temperature or pH responsive material so that the agent is released when the temperature or pH is altered.

[0021] These systems can also be used to connect a patient to a remote data storage or manipulation system, such as a watch-like device, small portable device, intra or extradermal implant, phone system devices (portable phones, answering services, beepers, office fax machines), portable computer, personal digital assistant (PDA, e.g., Palm Pilot™ systems), or to the internet (world wide web) or a computer accessible through devices that the physician or nurse can monitor or use to interact remotely with the implant.

Brief Description of the Drawings

[0022]

Figure 1 is a flow diagram of the implant (I), sensors (S), monitoring means (M), and actuators (A), showing the feedback path of the devices described herein.

Figure 2 is a flow diagram of a implant I connected to a sensor S and transponder including an energy coupler and control circuit connected to a remote reader (or monitoring device) which sends a signal to the actuator to act upon the implant.

Figure 3 is a flow diagram of a simple embodiment, in which the system includes the implant, sensor and actuating means.

Figures 4a-4c are schematics of the system connected to remote communication and/or data storage means. As shown in Figure 4a, the sensor transmits information to a computer with a display means. As shown in Figure 4b, the sensor again transmits to a computer which posts the information to a web page on an internet site. As shown in Figure 4c, the sensor transmits to a repeater unit worn by the patient, or in close proximity. The repeater unit amplifies outgoing and incoming transmissions, and is in communication with an outside computer.

Figure 5 is a schematic diagram of the implant, the

in-body digital device, the out-of-body digital device, a communication device and the world wide web.

Detailed Description of the Invention

I. Smart Responsive Implants or Implants

A. Implants and Implants

[0023] As generally understood, implants may be of a wide variety of shapes and configurations. In general the shape will be dictated by the location of internal implantation as well as function. Implanted devices may be of many forms. For example, such devices might include various types of stents, such as endoluminal stents, stent-grafts, grafts (including by-pass grafts), rings, hooks, sutures, wires, and tissue conduits. Such devices may be implanted in locations such as arteries, veins, venous fistulas, bile ducts, the ureter, fallopian tubes, and artificial spaces created surgically. Implants as contemplated herein might be implanted by various methods including needle, trocar, percutaneous implantation, surgical implantation, and endoscope. Implants would preferably be made of materials which did not provoke an immune response, and which resisted fouling, if tissue ingrowth were not desired.

[0024] In this regard, the function of the implant may be strictly to sense, to sense and store data, to sense, store and amplify or otherwise process data or to sense, store, process and transmit or otherwise communicate the information via electrical, electromagnetic, optical, radio, chemical, ultrasonic, thermal or other means. In addition to diagnostic as well as transmission functions, the implant may have innate support, augmentative or therapeutic functions to directly modulate the contiguous implant zone tissue or alter function in the peri-zone or at a distance.

[0025] Diagnostic implants may be simple spheres, pellets, wafers, slivers, chips, or weaves, fabrics or stamp-like arrays of these or other shapes. An example of simple support implants are tubes made of metal or plastic that is inserted into a body lumen, vessel or passage to keep the lumen open and prevent closure due to stricture or external compression. Implants are commonly used to keep open bile ducts for treatment of pancreatic cancer or cholangiocarcinoma, the oesophagus for strictures or cancer, the ureters to maintain drainage from the kidneys or blood vessels, i.e. coronary or peripheral arteries.

[0026] As used herein, implants can also refer to prosthetics for repair or replacement of tissue, connective tissue or bone, where the device supports or seals an injury due to surgery, trauma or disease, or which is seeded with cells to repair or replace tissue or an injury thereto.

[0027] Implants are generally made of a biocompatible material, which may be biodegradable or more typically, non-biodegradable. Exemplary materials include metals such as titanium, nitinol and surgical stainless steel, ce-

ramics, and synthetic polymeric materials. Non-biodegradable materials include polyethylene, TEFLON™ and pyrolytic carbon. Preferred biodegradable polymers include polylactic acid, polyglycolic acid, polycaprolactone and copolymers thereof.

B. Sensors

[0028] One or more sensors can be positioned in, on or as part of the implant. These can be used to measure temperature, mechanical forces such as stress and strain, pressure, and force; fluid flow properties such as flow rate and shear, electromagnetic fields, and chemical factors or variables, including pH, ion concentration, enzymes (presence of, activity of, or use of to measure other elements), and analyte concentrations or distributions. Sensors can also be used to monitor alterations in concentration or distribution of cells or tissues based on volume, or properties of the cells or tissue, such as stiffness, elasticity, surface adhesivity, and surface charge, changes in metabolic products, changes in antigenicity or cell surface expression, and the presence of foreign depositions including inorganic, organic and microbial materials.

[0029] Examples of applications of these sensors include measuring changes in weight by measuring changes in adipocyte cell volume and fat mass/lipid across a region such as a limb and measuring tissue fibrosis as changes in stiffness of a tendon, skin stiffness or muscle tension or rigidity.

[0030] Other applications relating to fouling of the implant over time, include measurements relating to protein deposition or formation of a bacterial film on the biliary stent, increase in calcification of a urinary stent, and neointimal thickening of an arterial stent, resulting in an increase in thickness, mass and wall shear.

[0031] Sensors can be located on the surface, inside a hollow or porous wall of the implant, or inside a device in communication with the body tissue via a conduit to the implant (solid, hollow, or porous). These sensors primarily include one or more of four classes of transducers: potentiometric, amperometric, optical, and physiochemical. An amperometric sensor monitors currents generated when electrons are exchanged between a biological system and an electrode. Blood glucose sensors frequently are of this type. Potentiometric sensors measure changes in potential between electrodes positioned apart from each other in an area over which a measurement is to be made, for example, as described by U.S. Patent No. 6,091,980 to Squire, et al.

[0032] The sensors may include means for transmitting a signal to monitoring means or directly to actuating means. The means for transmitting a signal may be hard wired or transmitted via radio waves or magnetic or mechanical means.

[0033] Sensors which may be used include those described in U.S. Patent No. 5,807,259 to Cimochoowski, et al.; U.S. Patent No. 5,833,603 to Kovacs, et al. and U.S.

Patent No. 5,709,225 to Budgifvars, et al. U.S. patent No. 5,807,258 describes ultrasonic sensors for monitoring the condition of a vascular graft.

[0034] A parameter indicative of the status of fluid flow is remotely monitored in a vessel, a natural graft, or a synthetic graft. One or more transducers are provided either in a wall of a synthetic graft or adjacent to a vessel or natural graft to monitor the parameter. A conformal array transducer or a tilted element is used to monitor fluid flow or velocity through the graft or vessel based on the effect of the fluid on ultrasonic waves produced by the transducers. The conformal array transducer comprises a plurality of elements that curve around the graft or vessel and are excited with an input signal provided by an implantable electronics circuit, producing ultrasonic waves that propagate into the fluid flowing within the graft or vessel. Transit time or Doppler measurements are made using an appropriate number of these transducer to determine either fluid flow or velocity. Various implantable electronic circuits are provided that enable a selected transducer to be driven and to receive an ultrasonic signal or a pressure signal indicative of the status of fluid flow monitored by the transducer. The implanted electronic circuit can be connected to an implanted radio frequency (RF) coil. An external coil that is connected to a power supply and monitoring console is coupled to the implanted RF coil to convey power and receive data signals from the transducer that are indicative of the parameter being monitored.

[0035] U.S. Patent No. 5,833,603 describes implantable transponders utilizing temperature sensors, strain sensors, pressure sensors, magnetic sensors, acceleration sensors, ionizing radiation sensors, acoustic wave sensors, chemical sensors including direct chemical sensors and dye based chemical sensors, and photosensors including imagers and integrated spectrophotometers. The transponder includes an energy coupler for wirelessly energizing the device with a remote energy source, and a control circuit for controlling and accessing the biosensor and for storing identifying data. The energy coupler can be an inductive circuit for coupling electromagnetic energy, a photoelectric transducer for coupling optical energy, or a piezoelectric transducer for coupling ultrasonic energy. The control circuit can be configured to delay, either randomly or by a fixed period of time, transmission of data indicative of the sensed parameter value to thereby prevent a data collision with an adjacent like device.

[0036] U.S. Patent No. 5,709,225 describes a magnetic field detector with a sensor whose capacitance changes in the presence of a magnetic field with a predefined strength, and a capacitance-controlled unit connected to the sensor. The capacitance-controlled unit sends a measurement signal to a detection unit. If a measurement signal parameter affected by capacitance exhibits a specific change over a predefined period of time, a detection signal is generated by the detection unit to indicate the presence of a magnetic field. The sensor's capacitance

also changes when the sensor moves, and this is utilized for measuring activity in an activity measurement circuit connected to the capacitance-controlled unit and for generating an activity signal on the basis of the measurement signal.

[0037] U.S. Patent No. 5,865,972 describes integrated electrochemical microsensors for chemical analysis, allowing the determination of concentration or concentration profile of at least one chemical compound with small size or molecular weight, under organic, inorganic, neutral or ionic form in an aqueous environment. The microsensor comprises an array of microelectrodes, assembled on a chip supported by an isolating substrate, and linked with at least one conductor protected by an insulating layer to a contact allowing the connection to a measuring apparatus. U.S. Patent No. 5,898,004 discloses crystalline colloidal array sensors. The hydrogels are capable of shrinking and swelling in response to specific stimuli applied thereto. As the hydrogels shrink or swell, the lattice structure of the CCA embedded therein changes, thereby changing the wavelength of light diffracted by the CCA. Thus by monitoring the change in diffracted wavelength, the concentration of a stimulus is determined. The gels can be modified to sense numerous different stimuli. U.S. Patent No. 5,883,310 describes a micromachined hot-wire shear stress sensor. The micromachined hot-wire anemometer having fast response times and higher sensitivities than conventional hot-wire anemometers is provided by micromachining doped polysilicon wires carried on silicon supports cantilevered from a substrate including one or more insulating layers disposed between said substrate and supports. The micromachined polysilicon hot-wire anemometer is fabricated using surface micromachining techniques. A shear stress sensor is micromachined to define a thin diaphragm over a cavity defined in a substrate underlying the diaphragm. The cavity is evacuated, sealed, and a thermistor disposed over the diaphragm. The thermistor is thus thermally insulated from the substrate and provides a low profile shear stress sensor for measuring flow rates in boundary layers above a flow surface. See also U.S. Patent No. 5, 511,428, 5,512,882, 5,526,703, 5,536,963, 6,053,873, 5,411,551 and EP 0 850 654 A1.

[0038] Sensors may be micromachines manufactured using MEMS technologies and microfabrication means, for example as described in U.S. Patent No. 5,797,898 to Santini, et al. or WO 99/64580 by Georgia Tech Research Corporation. As such sensors may be incorporated into the microstructure of a fabricated chip. A single, multiple or an array of chips may be fashioned and fabricated onto the body of the implant. These arrays may be on the ectoluminal or endoluminal surface of a cylindrical or spherical configuration.

[0039] The sensors can also include means for storage of data. Silicon wafer prepared using standard photolithographic or other manufacturing techniques can be included in the sensors for storage of data over time, which can be accessed routinely during the time the sensor is

implanted, or downloaded after removal of the implant containing the sensor.

C. Monitoring Means

[0040] A number of devices, both external and internal, can be used to receive and transmit signals from the sensors to the actuators. These may be radio transponders, light, or sound wave receivers and transmitters, or hard wired into the devices.

[0041] For example, the ultrasonic sensor described in U.S. Patent No. 5,807,258 can be used to monitor the condition of a vascular graft. One or more transducers are provided either in a wall of the implant or adjacent to the implant to monitor the parameter. A conformal array transducer or a tilted element is used to monitor fluid flow or velocity through the implant based on the effect of the fluid on ultrasonic waves produced by the transducers. The conformal array transducer comprises a plurality of elements that curve around the implant and are excited with an input signal provided by an implantable electronics circuit, producing ultrasonic waves that propagate into the fluid flowing within the graft or vessel. Transit time or Doppler measurements are made using an appropriate number of these transducer to determine either fluid flow or velocity. Various implantable electronic circuits are provided that enable a selected transducer to be driven and to receive an ultrasonic signal or a pressure signal indicative of the status of fluid flow monitored by the transducer. The implanted electronic circuit is connected to an implanted radio frequency (RF) coil. An external coil that is connected to a power supply and monitoring console is coupled to the implanted RF coil to convey power and receive data signals from the transducer that are indicative of the parameter being monitored.

[0042] In a preferred embodiment, the monitoring means will be connected to data communication and/or storage means, to provide for online monitoring of the stored data. Data can be stored in the implant or at a remote location. Means to access this information, and to download the data, are integrated so that the attending physician or nurse can monitor the patient long term, and provide corrections to the implant if necessary. As noted above, the storage means may be in the form of a silicon chip in the sensor or implant. Alternatively, the monitoring means connected to the sensor(s) includes data storage means. This will typically be a computer, which may be connected to the internet or phone lines, so that data can be remotely accessed through phone lines (including beepers), other computers, or personal digital assistant (PDAs).

D. Actuators

[0043] Actuators will typically consist of micromachined devices, or form a part of the implant. Alternatively, they can be in the form of reservoirs, switches or valves.

[0044] U.S. patent No. 5,536,963 describes a micro-mechanical structure or microactuator based upon the piezoelectric, pyroelectric, and electrostrictive properties of ferroelectric thin film ceramic materials such as PZT with a thickness between 0.1 and 10 micrometers, and method of manufacture thereof. The thin film ceramic material is sandwiched between first and second electrodes and may contain an intermediate electrically insulating thin film. This structure with electrodes is formed on a deformable or movable structure integral to a semiconductor or bulk ceramic substrate. Electrical connection is established between the upper and lower electrodes. A potential difference or voltage is established between the electrical interconnection points to produce a force, movement, or mechanical deformation. The patent also discloses method for making such micromechanical structures or microactuators.

[0045] The implant may function as a conduit for fluids, solutes, electric charge, light, or other materials. In one embodiment, hollows within the implant walls, or the implant itself, can be filled with a substance, such as a gel, that has a sensing functionality associated with it. In an application for sensing based on binding to a substrate or reaction mediated by an enzyme, the substrate or enzyme can be immobilized in the interior of the implant, to create an integral needle/sensor.

[0046] Wave guides can be incorporated into the device to direct light to a specific location, or for detection, for example, using means such as a pH dye for color evaluation. Similarly, heat, electricity, light or other energy forms may be precisely transmitted to directly stimulate, damage, or heal a specific tissue or intermediary (e.g., tattoo remove for dark skinned persons), or diagnostic purposes, such as measurement of blood glucose based on IR spectra or by chromatographic means, measuring a color change in the presence of immobilized glucose oxidase in combination with an appropriate substrate.

E. The System

[0047] The sensor detects one or more physical properties of its surrounding environment, and provides an output signal of the detected physical property to the control circuit. The control circuit then sends data indicative of the detected physical property to a remote reader with an energy coupler or with a different energy coupler. The control circuit can be encoded with identifying data before or after implantation. Such data may relate to the sensor, the patient into which the device is implanted or both. The identifying data may also be a unique tag for accessing data stored in a remote data bank, such as a personal computer or a memory device in a remote reader. Hence, even after implantation of the implant with sensor(s), identifying data can be retrieved from control circuit in a non-invasive manner, as can data corresponding to sensed parameter values.

[0048] Ultrasonic and optical coupling can be used with a transponder for energizing and providing command sig-

nals to the transponder, and for transmitting identifying data, including unique tags, from the transponder to a remote reader. A transponder can include more than one energy coupler, particularly where it is advantageous to energize the sensor with one form of energy, and transmit data using another. Where desirable, a third energy coupler can also be used to receive control commands from an external source using either the same or different forms of energy as those used for energizing the transponder and transmitting data therefrom.

[0049] Figure 1 is a flow diagram showing the interaction between the implant (I), sensor(s) (S), monitoring means (M), and actuating means (A), in the most typical embodiment. Figure 2 is a flow diagram of a more complex embodiment, wherein the implant I is connected to a sensor S and transponder including an energy coupler and control circuit (referred to jointly as a biosensing transponder, as described for example, in U.S. Patent No. 5,833,603). This is in turn connected to a remote reader (or monitoring device) which sends a signal to the actuator to act upon the implant. Figure 3 is a flow chart of the simplest embodiment, in which the system includes the implant, sensor and actuating means.

[0050] One embodiment of system described herein is a telemetry system of nested communication loops. A sensor may communicate with a contiguous device, such as an actuator associated with an implanted device, an implanted device, or with a free-standing electronic communication device, or with a computer accessing the world wide web. In one embodiment of the invention, all these devices may communicate with each other, or in specific hierarchies.

[0051] The processing units of implants might be an integrated circuit with dedicated functions. The sensing units might also be specialized integrated circuits, known colloquially as "biochips".

[0052] Included with the implant may be a sensor that generates a signal in response to conditions detected by the sensor. Included with the sensor is a memory means for storing information regarding the conditions, transmitting and receiving means, actuating means for carrying out a response by the implant to conditions sensed by the sensor, and a power source. The sensor optionally includes an information processing means. Various sensors may be employed to detect mechanical, sonic, electrical, chemical, temperature, and optical conditions, among others. Mechanical conditions sensed might include pressure, dimension, flow, and vibration. The sensor generates a signal after sensing said conditions, which signal is sent to the transmitter, or which signal may be stored in the memory means. The transmitter might transmit the signal by optical fiber, by wire, or wirelessly, using power from the power source. The sensor might be programmed to transmit continuously, but more likely it would be programmed to transmit on a regular schedule to conserve energy, and transmit more frequently upon the sensing of a certain condition. In one embodiment of the invention, the power source might be

a battery. Optical transmission might be through optical fibers, while wired transmission might be through electrical transmission over an electrical conductor. Wireless transmission might take place through radio wave signals, or ultrasonically. In one embodiment of the invention, a standard communication protocol might be employed, such as a version of BLUETOOTH™, which is promulgated by the Bluetooth Special Interest Group (which includes 3Com, IBM, Intel, Lucent, Microsoft and Nokia, among others). In one embodiment of the invention, the sensor may both transmit and receive information.

[0053] In one embodiment, the person having the implant might wear on his person, or keep in close proximity, a repeater unit to strengthen the signal generated by the implanted sensor. In that manner the sensor could include a smaller power source, and thus be more compact. The repeating unit might also include a more sensitive receiver than the implant unit, and thus aid in transmissions back to the implanted sensor.

[0054] In one embodiment, a person such as a physician, or the patient could monitor the transmissions from the sensor by means of a portable device, such as a personal digital assistant, portable computer, internet appliance, cellular telephone, two-way radio, web-enabled television, or watch communicator. In another embodiment, a person might monitor the transmissions from the sensor by using an ordinary telephone linked to a command menu, or which has speech to text and text to speech capabilities allowing the user to request the desired presentation of data. In another embodiment, the sensor could transmit to a receiving unit which would post the information sent by the implant sensor to a web page, accessible by the patient or the physician. In another embodiment, the web page would be accessible only by password, and the ability to issue commands to the device might be further password-protected.

[0055] In one embodiment, a person monitoring the information sent by the implant sensor could transmit information back to the implant sensor. Such information might be commands to be carried out through the actuator. For example, if a sensor on a stent detected a mechanical narrowing of the internal passage, a physician might read that information from the web posting, and send a command back to the stent to the actuator to widen the passage. In that case the actuator might be a small mechanism in the stent that forces the stent to open more widely. In another example, an optical sensor might detect the presence of unwanted cellular accumulation in the interior of the stent. A physician might read that information, and send a command to the stent to the actuator to release a small amount of a protease to dissolve the accumulation. In that case the effector would be a reservoir containing protease, where a release mechanism on the reservoir could release a measured amount of protease. In another embodiment, the implant might be an implant in a deep abscess in a patient. The implant might be an bandage, including expandable foam to pro-

mote healing. The sensor might monitor local temperature to assess the presence or absence of infection. A monitoring, physician, observing a tell-tale warming, might direct the actuator to release a certain amount of an antibiotic solution.

[0056] A person, such as a physician, might also communicate with the sensor directing it to issue an alert if certain conditions were sensed. For example, sensing of too great a narrowing of a vessel, or an erratic flow rate through a vessel, might be conditions for which a physician might direct the sensor to send an alert.

[0057] Depending upon the amount of information recorded by the sensor, it might be directed to download the information through the transmitter for permanent storage outside the sensor at various times. This would free up memory space in the sensor.

[0058] In another embodiment, the information processing means may be programmed to have the actuator carry out certain actions in response to the sensing of certain conditions. This programming might be effected through transmissions by a physician. For example, the physician might program the sensor, by remote transmissions, to carry out a certain schedule of release of an antibiotic. Alternatively, the physician might program the sensor to release antibiotic at one schedule if a certain temperature were sensed, and another, more infrequent schedule, if another temperature were sensed. For instance, the sensor might be programmed to have the actuator release 0.5 ml of penicillin per ten hours if a temperature of 102 degrees Fahrenheit (33.9 degrees Centigrade) were sensed, but to reduce that schedule to 0.3 ml of penicillin per twenty hours when the temperature declined to 99.9 degrees Fahrenheit (37.8 degrees Centigrade).

[0059] As shown in Figure 4a, in one embodiment of the system, the implant coupled to the sensor transmits information to a computer with a display means. The computer might be any number of devices capable of receiving information, including personal digital assistants, pagers, telephones, internet appliances, watch communicators, and web-enabled televisions, as discussed above. The communication might occur by some standard protocol, such as BLUETOOTH™. The user could transmit commands or inquiries directly back to the implant.

[0060] As shown in Figure 4b, the implant coupled to the sensor again transmits to a computer. However, the computer in this case might post the information to a web page on an internet site, probably password-protected. A patient or physician could access this information by using a communications device to access the web site. Commands could be sent directly to the implant from the accessing device, or via the web page and prompts on the web page (Figure 4b only shows the direct command route).

[0061] As shown in Figure 4c, the implant is coupled to a sensor, which transmits to a repeater unit worn by the patient, or in close proximity. The repeater unit am-

plifies outgoing and incoming transmissions, and is in communication with an outside computer.

[0062] As shown in Figure 5, implant (10), in-body digital device (160), out-of-body digital device (170), and communication device (180) communicate with implant (10) and with the world wide web (150), preferably by posting to a web page (not shown). This might be referred to as a "nested loop". In another embodiment, in-body digital device (160), out-of-body digital device (170), and communication device (180) all communicate with each other as well (not shown). These communications can encompass information received from the sensors (not shown) associated with the implant (10), as well as commands given to the actuator (not shown) of the implant (10).

F. Drugs and Drug Releasing Means

[0063] Any natural or synthetic, organic or inorganic molecule or mixture thereof can be delivered. In one embodiment, the implant is used to deliver drugs systemically to a patient in need thereof. In another embodiment, the construction and placement of the implant in a patient enables the localized release of drugs that may be too potent for systemic delivery. As used herein, drugs are organic or inorganic molecules, including proteins, nucleic acids, polysaccharides and synthetic organic molecules, having a bioactive effect, for example, anaesthetics, vaccines, chemotherapeutic agents, hormones, metabolites, sugars, immunomodulators, antioxidants, ion channel regulators, and antibiotics. The drugs can be in the form of a single drug or drug mixtures and can include pharmaceutically acceptable carriers. In another embodiment, molecules are released *in vitro* in any system where the controlled release of a small (milligram to nanogram) amount of one or more molecules is required, for example, in the fields of analytic chemistry or medical diagnostics. Molecules can be effective as pH buffering agents, diagnostic agents, and reagents.

U.S. Patent No. 5,797,898 to Santini, et al., describes implants for delivery of a wide variety of molecules. Implant or implants are miniaturized devices constructed using methods commonly applied to the manufacture of integrated circuits such as ultraviolet (UV) photolithography, reactive ion etching, and electron beam evaporation. The implants provide control over the rate the molecules are released as well as the time at which release begins. The time of release can be controlled passively or actively.

[0064] In the simplest of the embodiments described herein, the implant is formed of a material which is itself responsive to the environment, for example, to temperature or pH, which causes a change in the material, for example, an increase in pore size, thereby effecting release of the bioactive, prophylactic or diagnostic agent as needed. An example of such a situation is when the tissue around the implant becomes infected, thereby changing both the temperature and the pH. Use of a tem-

perature responsive material that increases porosity as the temperature increases can be used to deliver antibiotic only when, or in an increased amount when, infection is present.

G. Devices for Treating Chronic Cardiac Contractile Dysfunction

[0065] The micromachine actuators described herein can also be used to support or reinforce heart wall muscle in patients with congestive heart failure. These devices are implanted into the heart muscle, and contains both sensor and actuator means that synchronize expansion and contraction of devices secured to the heart wall muscle with the contraction and expansion of the normal, but impaired heart wall. By assisting the heart to function, patients that otherwise would die are provided with relief from the symptoms of the disease, including fluid on the lungs or fluid in the belly, liver and legs.

Claims

1. A system for monitoring and responding to the environment of an implanted device (10) comprising:
 - one or more sensors (40) configured for monitoring data relating to variables selected from the group consisting of electrical, magnetic, mechanical, fluid flow, chemical, biochemical, and thermal properties in the device or its environment in a patient,
 - at least one actuator (20) configured for implementing a response to the monitored data in the device; and
 - means for communication to one of a series of nested loops of information exchange;

wherein the one or more sensors (40) directly interact with the device (10) through the at least one actuator (20) such that data transmitted from the one or more sensors (40) to the at least one actuator (20) causes a configurational change in the device (10); wherein the one or more sensors (40) and the at least one actuator (20) are configured for control by at least one apparatus external to the implantable device, and wherein one or more sensors (40) are in, on, or part of the device (10), the system being **characterised in that** the one or more sensors include transmitting and receiving means.
2. The system of claim further comprising a data storage means.
3. The system of claim 2 wherein the data storage means is configured to be placeable on the device or contiguous to the device or within or on the body of the patient.
4. The system of claim 1 further comprising a telemetry means.
5. The system of claim 4 wherein the telemetry means is an analog or digital electronic device.
6. The system of claim 1 comprising an external input connected through loops to effectuate change in the device from the at least one actuator.
7. The system of claim 1 further comprising a monitoring means configured for positioning external to the patient.
8. The system of claim 1 wherein the sensor is configured to detect changes in pH, temperature, ion concentration, or analyte concentration.
9. The system of claim 1 wherein the sensor is configured to detect changes in temperature, dimension, vibration, turbulence, pressure, moisture, magnetism, electric potential, and electric current and mechanical or fluid flow properties.
10. The system of claim 9 wherein the mechanical property is stress, strain, shear, flow rate, or pressure.
11. The system of claim 1 wherein the sensor is configured to detect a change in placement of the device
12. The system of claim 1 wherein the actuator is a micromachine that modifies the shape or position of the implant in response to a signal from a sensor.
13. The system of claim 1 wherein the device comprises a bioactive, diagnostic, or prophylactic agent or a pH modifying agent that is capable of being released into the environment.
14. The system of claim 13 wherein the agent is capable of being released by diffusion.
15. The system of claim 14 wherein the rate of diffusion is capable of being increased by a change in a variable in the environment.
16. The system of claim 15 wherein the agent is capable of being released in response to a signal from a sensor.
17. The system of claim 13 wherein the actuator is configured to release the agent mechanically by opening means for delivering or retaining the agent.
18. The system of claim 1 further comprising transmitting and receiving means to the one or more sensors.
19. The system of claim 1 further comprising means for

remotely accessing the data.

20. The system of claim 1 wherein the one or more sensors are connected to means for transmitting or receiving data from a computer or phone communication means. 5
21. The system of claim 1 wherein at least one sensor is configured to measure fouling of the device or at least one sensor over time. 10
22. The system of claim 21 wherein at least one sensor is configured to measure protein deposition or formation of a bacterial film on a biliary stent, increase in calcification of a urinary stent, and neointimal thickening of an arterial stent, resulting in an increase in thickness, mass and wall shear. 15
23. The system of claim 1 wherein the device is suitable for implantation in an artery, vein, venous fistula, bile duct, ureter, fallopian tube or a surgically created artificial space. 20
24. The system of claim 1 wherein the device is a stent. 25
25. The system or claim 1 wherein the one or more sensors are incorporated into one or more chips on the device.
26. The system of claim further comprising a power source. 30
27. The system of claim 1 comprising:
- (a) one or more sensors for monitoring the general environment of the implanted device; 35
 - (b) monitoring means; and
 - (c) at least one actuator;
- wherein the one or more sensors are configured for communicating information to the monitoring means and to each other, and are configured for communicating commands to the actuator. 40
28. The system of claim 27 wherein the one or more sensors are configured for communicating information to a computer transmitting the information to another computer via the internet. 45
29. The system of claim 28 wherein the transmission over the Internet to another computer is via a posting to the world wide web. 50
30. An implantable device (10) comprising: 55
- one or more sensors (40) configured for monitoring at least one condition;
 - at least one actuator (20) configured for imple-

menting a response to the monitored condition in the device; and
means for communication to one of a series of nested loops of information exchange;

wherein the one or more sensors (40) directly interact with the device (10) through the at least one actuator (20); wherein
the one or more sensors (40) and the at least one actuator (20) are configured for control by at least one apparatus external to the implantable device, and
wherein the one or more sensors (40) are in, on, or part of the device (10), the device being **characterised in that** the one or more sensors include transmitting and receiving means.

31. The device of claim 30 which is suitable for implantation in an artery, vein, venous fistula, bile duct, ureter, fallopian tube, or a surgically created artificial space.
32. The device of claim 30 wherein the one or more sensors are incorporated into one or more chips on the device.

Patentansprüche

1. System zum Überwachen der und Reagieren auf die Umgebung einer implantierten Vorrichtung (10), umfassend:
- einen oder mehrere Sensoren (40), der/die konfiguriert ist/sind, um Daten bezüglich Variablen, welche aus der Gruppe, bestehend aus elektrischen, magnetischen, mechanischen, Strömungs-, chemischen, biochemischen und thermischen Eigenschaften ausgewählt sind, in der Vorrichtung oder ihrer Umgebung bei einem Patienten zu überwachen, mindestens ein Bedienungselement (20), das konfiguriert ist, um eine Reaktion auf die überwachten Daten in der Vorrichtung zu implementieren; und
Mittel zur Kommunikation an eine von einer Reihe von verschachtelten Informationsaustauschschleifen;
- wobei der eine oder die mehrere Sensoren (40) über das mindestens eine Bedienungselement (20) mit der Vorrichtung (10) derart direkt interagiert/interagieren, dass Daten, die von dem einen oder den mehreren Sensoren (40) auf das mindestens eine Bedienungselement (20) übermittelt wurden, in der Vorrichtung (10) eine Konfigurationsänderung bewirken;
wobei der eine oder die mehreren Sensoren (40) und

- das mindestens eine Bedienungselement (20) konfiguriert ist/sind, um mindestens ein Gerät extern von der implantierbaren Vorrichtung zu steuern, und wobei einer oder mehrere Sensoren (40) in, auf oder Teil von der Vorrichtung (10) ist/sind, wobei das System **dadurch gekennzeichnet ist, dass** der eine oder die mehreren Sensoren Übermittlungs- und Empfangsmittel aufweist/aufweisen.
2. System nach Anspruch 1, das ferner ein Datenspeicherungsmittel umfasst.
 3. System nach Anspruch 2, wobei das Datenspeicherungsmittel derart konfiguriert ist, dass es auf der Vorrichtung oder angrenzend an die Vorrichtung oder innerhalb des oder auf dem Körper des Patienten platzierbar ist.
 4. System nach Anspruch 1, das ferner ein Telemetriemittel umfasst.
 5. System nach Anspruch 4, wobei das Telemetriemittel eine analoge oder digitale elektronische Vorrichtung ist.
 6. System nach Anspruch 1, das einen externen Eingang umfasst, der durch Schlaufen angeschlossen ist, um von dem mindestens einen Bedienungselement eine Änderung in der Vorrichtung herbeizuführen.
 7. System nach Anspruch 1, das ferner ein Überwachungsmittel umfasst, das zur Positionierung extern vom Patienten konfiguriert ist.
 8. System nach Anspruch 1, wobei der Sensor konfiguriert ist, um Änderungen des pH-Werts, der Temperatur, der Ionenkonzentration oder der Analytkonzentration zu erfassen.
 9. System nach Anspruch 1, wobei der Sensor konfiguriert ist, um Änderungen der Temperatur, der Dimension, der Vibration, der Turbulenz, des Drucks, des Feuchtegehalts, des Magnetismus, des elektrischen Potentials und des elektrischen Stroms und der mechanischen oder Strömungseigenschaften zu erfassen.
 10. System nach Anspruch 9, wobei die mechanische Eigenschaft Spannung, Beanspruchung, Scherkraft, Strömung oder Druck ist.
 11. System nach Anspruch 1, wobei der Sensor konfiguriert ist, um eine Änderung der Platzierung der Vorrichtung zu erfassen.
 12. System nach Anspruch 1, wobei das Bedienungselement eine Mikromechanik ist, welche die Form oder Position des Implantats als Reaktion auf ein Signal von einem Sensor modifiziert.
 13. System nach Anspruch 1, wobei die Vorrichtung ein bioaktives, diagnostisches oder prophylaktisches Agens oder ein pH-Wert modifizierendes Agens, das in die Umgebung freigegeben werden kann, umfasst.
 14. System nach Anspruch 13, wobei das Agens mittels Diffusion freigegeben werden kann.
 15. System nach Anspruch 14, wobei die Diffusionsrate durch eine Änderung einer Variablen in der Umgebung erhöht werden kann.
 16. System nach Anspruch 15, wobei das Agens als Reaktion auf ein Signal von einem Sensor freigegeben werden kann.
 17. System nach Anspruch 13, wobei das Bedienungselement konfiguriert ist, um das Agens mechanisch durch Öffnungsmittel zum Überbringen oder Zurückhalten des Agens freizugeben.
 18. System nach Anspruch 1, das ferner Übermittlungs- und Empfangsmittel für den einen oder die mehreren Sensoren umfasst.
 19. System nach Anspruch 1, das ferner Mittel zum fernem Zugreifen auf die Daten umfasst.
 20. System nach Anspruch 1, wobei der eine oder die mehreren Sensoren an Mittel zum Übermitteln oder Empfangen von Daten von einem Computer oder Telefonkommunikationsmittel angeschlossen sind.
 21. System nach Anspruch 1, wobei mindestens ein Sensor konfiguriert ist, um die Verschmutzung der Vorrichtung oder mindestens eines Sensors im Zeitablauf zu messen.
 22. System nach Anspruch 21, wobei mindestens ein Sensor konfiguriert ist, um die Proteinablagerung oder Bildung eines bakteriellen Films auf einem biliären Stent, die Erhöhung der Verkalkung eines Harnstents und die neointimale Verdickung eines arteriellen Stents, was in einer Erhöhung der Dicke, Masse und Scherkraft resultiert, zu messen.
 23. System nach Anspruch 1, wobei die Vorrichtung zur Implantierung in eine Arterie, Vene, Venenfistel, einen Gallengang, Harnleiter, Eileiter oder einen chirurgisch erzeugten künstlichen Raum geeignet ist.
 24. System nach Anspruch 1, wobei die Vorrichtung ein Stent ist.

25. System nach Anspruch 1, wobei der eine oder die mehreren Sensoren in einen oder mehrere Chips auf der Vorrichtung inkorporiert ist/sind.
26. System nach Anspruch 1, das ferner eine Stromquelle umfasst. 5
27. System nach Anspruch 1, umfassend:
- (a) einen oder mehrere Sensoren zum Überwachen der allgemeinen Umgebung der implantierten Vorrichtung; 10
- (b) Überwachungsmittel; und
- (c) mindestens ein Bedienungselement;

wobei der eine oder die mehreren Sensoren konfiguriert ist/sind, um Informationen an die Überwachungsmittel und einander zu kommunizieren und um Befehle an das Bedienungselement zu kommunizieren. 20

28. System nach Anspruch 27, wobei der eine oder die mehreren Sensoren konfiguriert ist/sind, um Informationen an einen Computer, der die Informationen über das Internet an einen anderen Computer übermittelt, zu kommunizieren. 25
29. System nach Anspruch 28, wobei die Übermittlung über das Internet an einen anderen Computer über das Entsenden an das World Wide Web geschieht. 30
30. Implantierbare Vorrichtung (10), umfassend:

einen oder mehrere Sensoren (40), der/die konfiguriert ist/sind, um mindestens einen Zustand zu überwachen; 35

mindestens ein Bedienungselement (20), das konfiguriert ist, um eine Reaktion auf den überwachten Zustand in der Vorrichtung zu implementieren; und 40

Mittel zur Kommunikation an eine von einer Reihe von verschachtelten Schleifen Informationsaustausch;

wobei der eine oder die mehrere Sensoren (40) über das mindestens eine Bedienungselement (20) mit der Vorrichtung (10) direkt interagiert/interagieren; wobei 45

der eine oder die mehreren Sensoren (40) und das mindestens eine Bedienungselement (20) konfiguriert ist/sind, um mindestens ein Gerät extern von der implantierbaren Vorrichtung zu steuern, und wobei der einer oder die mehreren Sensoren (40) in, auf oder Teil von der Vorrichtung (10) ist/sind, wobei die Vorrichtung **dadurch gekennzeichnet ist, dass** der eine oder die mehreren Sensoren Übermittlungs- und Empfangsmittel aufweist/aufweisen. 50 55

31. Vorrichtung nach Anspruch 30, die zur Implantierung in eine Arterie, Vene, Venenfistel, einen Gallengang, Harnleiter, Eileiter oder einen chirurgisch erzeugten künstlichen Raum geeignet ist.
32. Vorrichtung nach Anspruch 30, wobei der eine oder die mehreren Sensoren in einen oder mehrere Chips auf der Vorrichtung inkorporiert ist/sind.

Revendications

1. Système pour surveiller l'environnement d'un dispositif implanté (10) et pour y répondre comprenant :

un ou plusieurs capteurs (40) configurés pour surveiller les données liées à des variables choisies dans le groupe constitué par les propriétés électriques, magnétiques, mécaniques, d'écoulement de fluide, chimiques, biochimiques et thermiques dans le dispositif ou son environnement chez un patient, au moins un dispositif (20) d'actionnement configuré pour mettre en oeuvre une réponse aux données surveillées dans le dispositif ; et un moyen de communication avec une boucle imbriquée parmi une série de boucles imbriquées d'échange d'informations;

dans lequel le un ou plusieurs capteurs (40) interagissent directement avec le dispositif (10) via le au moins un dispositif (20) d'actionnement de telle sorte que les données transmises depuis le un ou plusieurs capteurs (40) vers le au moins un dispositif (20) d'actionnement entraînent une modification de configuration dans le dispositif (10) ; dans lequel le un ou plusieurs capteurs (40) et le au moins un dispositif (20) d'actionnement sont configurés pour la commande par au moins un appareil externe au dispositif implantable et dans lequel un ou plusieurs capteurs (40) sont dans le dispositif (10) ou sont une partie du dispositif (10), le système étant **caractérisé en ce que** le un ou plusieurs capteurs incluent un moyen de transmission et de réception.

2. Système selon la revendication 1 comprenant en outre un moyen de stockage des données.
3. Système selon la revendication 2 dans lequel le moyen de stockage des données est configuré de manière à pouvoir être placé sur le dispositif ou de manière contiguë au dispositif ou dans ou sur le corps du patient.
4. Système selon la revendication 1 comprenant en outre un moyen de télémétrie.
5. Système selon la revendication 4 dans lequel le

- moyen de télémétrie est un dispositif électronique analogique ou numérique.
6. Système selon la revendication 1 comprenant une entrée externe connectée par des boucles pour entraîner une modification dans le dispositif depuis le au moins un dispositif d'actionnement.
7. Système selon la revendication 1 comprenant en outre un moyen de surveillance configuré pour un positionnement à l'extérieur du patient.
8. Système selon la revendication 1 dans lequel le capteur est configuré pour détecter des modifications du pH, de la température, de la concentration d'ions, ou de la concentration d'analyte.
9. Système selon la revendication 1 dans lequel le capteur est configuré pour détecter des modifications de la température, des dimensions, de la vibration, de la turbulence, de la pression, de l'humidité, du magnétisme, du potentiel électrique et du courant électrique et des propriétés mécaniques ou d'écoulement de fluide.
10. Système selon la revendication 9 dans lequel la propriété mécanique est la contrainte, la déformation, le cisaillement, le débit ou la pression.
11. Système selon la revendication 1 dans lequel le capteur est configuré pour détecter une modification dans le placement du dispositif.
12. Système selon la revendication 1, dans lequel le dispositif d'actionnement est une micromachine qui modifie la forme ou la position de l'implant en réponse à un signal émis par un capteur.
13. Système selon la revendication 1, dans lequel le dispositif comprend un agent bioactif, de diagnostic ou prophylactique, ou un agent de modification du pH qui est capable d'être libéré dans l'environnement.
14. Système selon la revendication 13 dans lequel l'agent est capable d'être libéré par diffusion.
15. Système selon la revendication 14 dans lequel le taux de diffusion est capable d'être augmenté par une modification d'une variable de l'environnement.
16. Système selon la revendication 15 dans lequel l'agent est capable d'être libéré en réponse à un signal émis par un capteur.
17. Système selon la revendication 13 dans lequel le dispositif d'actionnement est configuré pour libérer l'agent mécaniquement par des moyens d'ouverture pour délivrer ou retenir l'agent.
18. système selon la revendication 1 comprenant en outre un moyen de transmission et de réception vers le un ou plusieurs capteurs.
19. Système selon la revendication 1 comprenant un moyen pour accéder à distance aux données.
20. Système selon la revendication 1 dans lequel le un ou plusieurs capteurs sont reliés à un moyen pour transmettre ou recevoir des données depuis un ordinateur ou un moyen de communication téléphonique.
21. Système selon la revendication 1 dans lequel au moins un capteur est configuré pour mesurer l'encrassement du dispositif ou d'au moins un capteur dans le temps.
22. Système selon la revendication 21 dans lequel au moins un capteur est configuré pour mesurer le dépôt de protéine ou la formation d'un film bactérien sur un stent biliaire, l'augmentation de la calcification d'un stent urinaire, et l'épaississement néo-intimal d'un stent artériel, entraînant une augmentation de l'épaisseur, de la masse et du cisaillement pariétal.
23. Système selon la revendication 1 dans lequel le dispositif est adapté pour être implanté dans une artère, une veine, une fistule veineuse, un canal biliaire, un uretère, une trompe de Fallope ou un espace artificiel créé par chirurgie.
24. Système selon la revendication 1 dans lequel le dispositif est un stent.
25. Système selon la revendication 1 dans lequel le un ou plusieurs capteurs sont incorporés dans une ou plusieurs puces sur le dispositif.
26. Système selon la revendication 1 comprenant en outre une source d'énergie.
27. Système selon la revendication 1 comprenant :
- (a) un ou plusieurs capteurs pour surveiller l'environnement général du dispositif implanté ;
- (b) un moyen de surveillance ; et
- (c) au moins un dispositif d'actionnement ;
- dans lequel le un ou plusieurs capteurs sont configurés pour communiquer des informations au moyen de surveillance et entre eux, et sont configurés pour communiquer des ordres au dispositif d'actionnement.
28. Système selon la revendication 27 dans lequel le un ou plusieurs capteurs sont configurés pour communiquer des informations à un ordinateur transmettant

les informations à un autre ordinateur via l'Internet.

29. Système selon la revendication 28 dans lequel la transmission par l'Internet à un autre ordinateur se fait par une publication sur le World Wide Web. 5

30. Dispositif implantable (10) comprenant :

un ou plusieurs capteurs (40) configurés pour surveiller au moins une condition ; 10
 au moins un dispositif (20) d'actionnement configuré pour mettre en oeuvre une réponse à la condition surveillée dans le dispositif ; et
 un moyen pour communiquer avec une boucle imbriquée parmi plusieurs boucles imbriquées d'échange d'information ; 15

dans lequel le un ou plusieurs capteurs (40) interagissent directement avec le dispositif (10) *via* le au moins un dispositif (20) d'actionnement ; dans lequel 20
 le un ou plusieurs capteurs (40) et le au moins un dispositif (20) d'actionnement sont configurés pour commander au moins un appareil externe au dispositif implantable, et

dans lequel le un ou plusieurs capteurs (40) sont 25
 dans le dispositif, sur le dispositif ou sont une partie du dispositif (10), le dispositif étant **caractérisé en ce que** le un ou plusieurs capteurs incluent un moyen de transmission et de réception. 30

31. Dispositif selon la revendication 30 qui est adapté à l'implantation dans une artère, une veine, une fistule veineuse, un canal biliaire, un uretère, une trombe de Fallope ou un espace artificiel créé par chirurgie. 35

32. Dispositif selon la revendication 30 dans lequel un ou plusieurs capteurs sont incorporés dans une ou plusieurs puces sur le dispositif. 40

45

50

55

60

FIG. 1

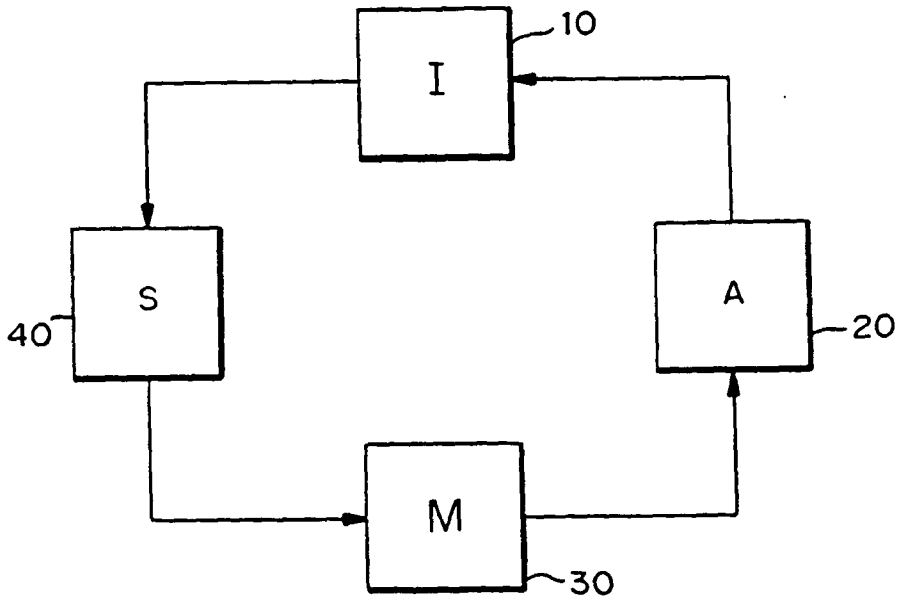
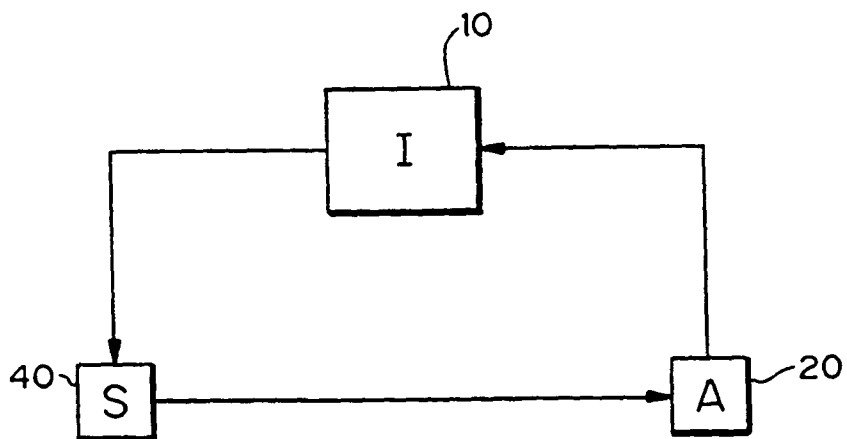

FIG. 3



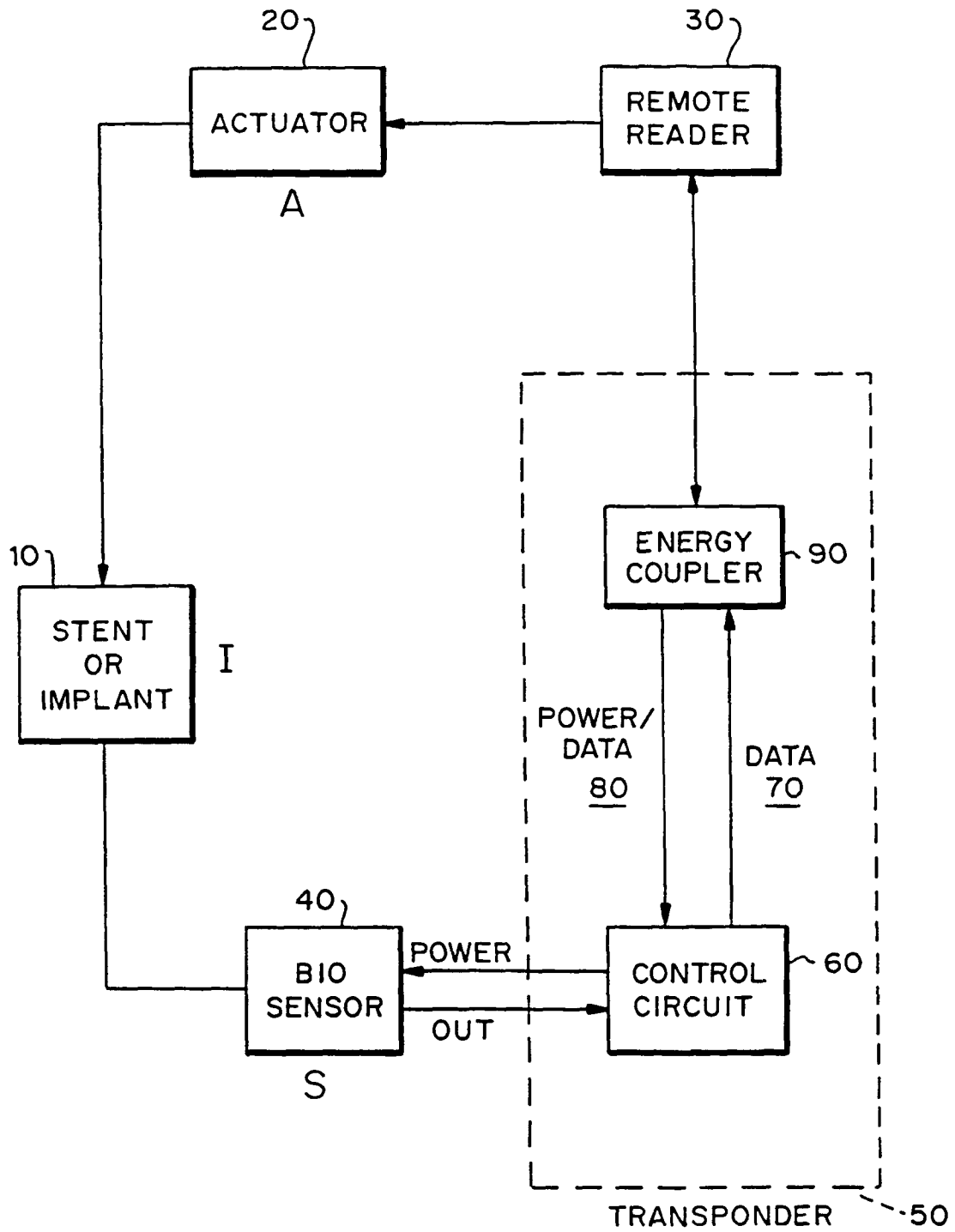

FIG. 2

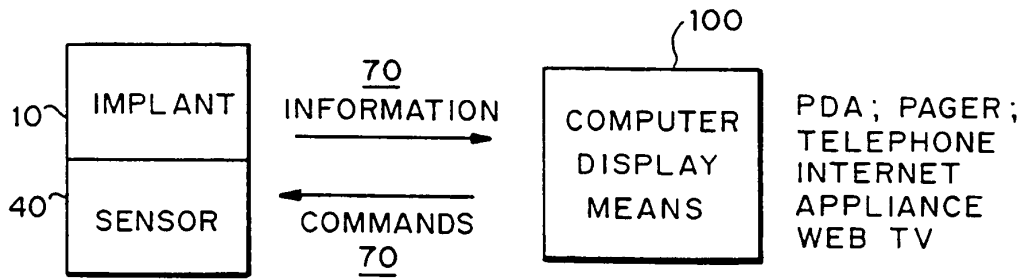

FIG. 4A

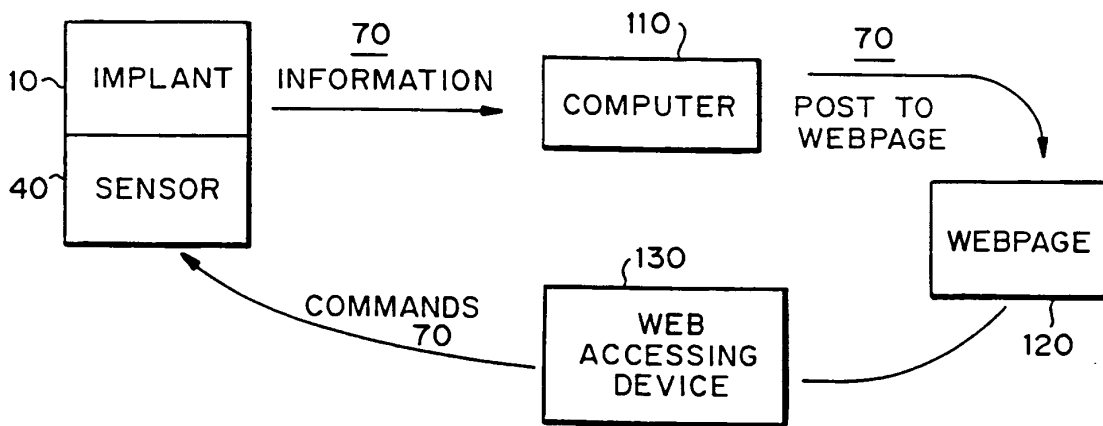

FIG. 4B

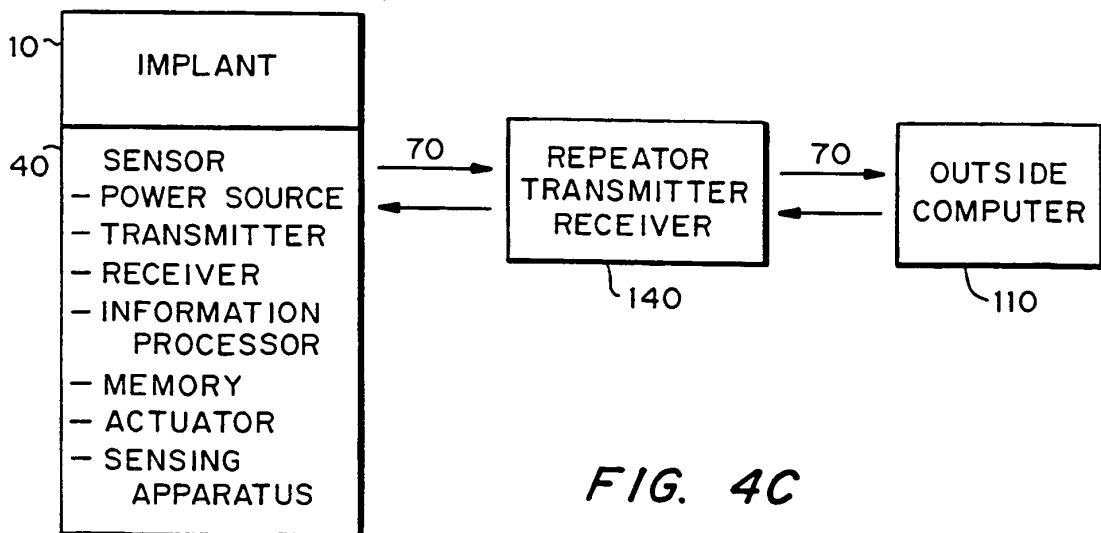

FIG. 4C

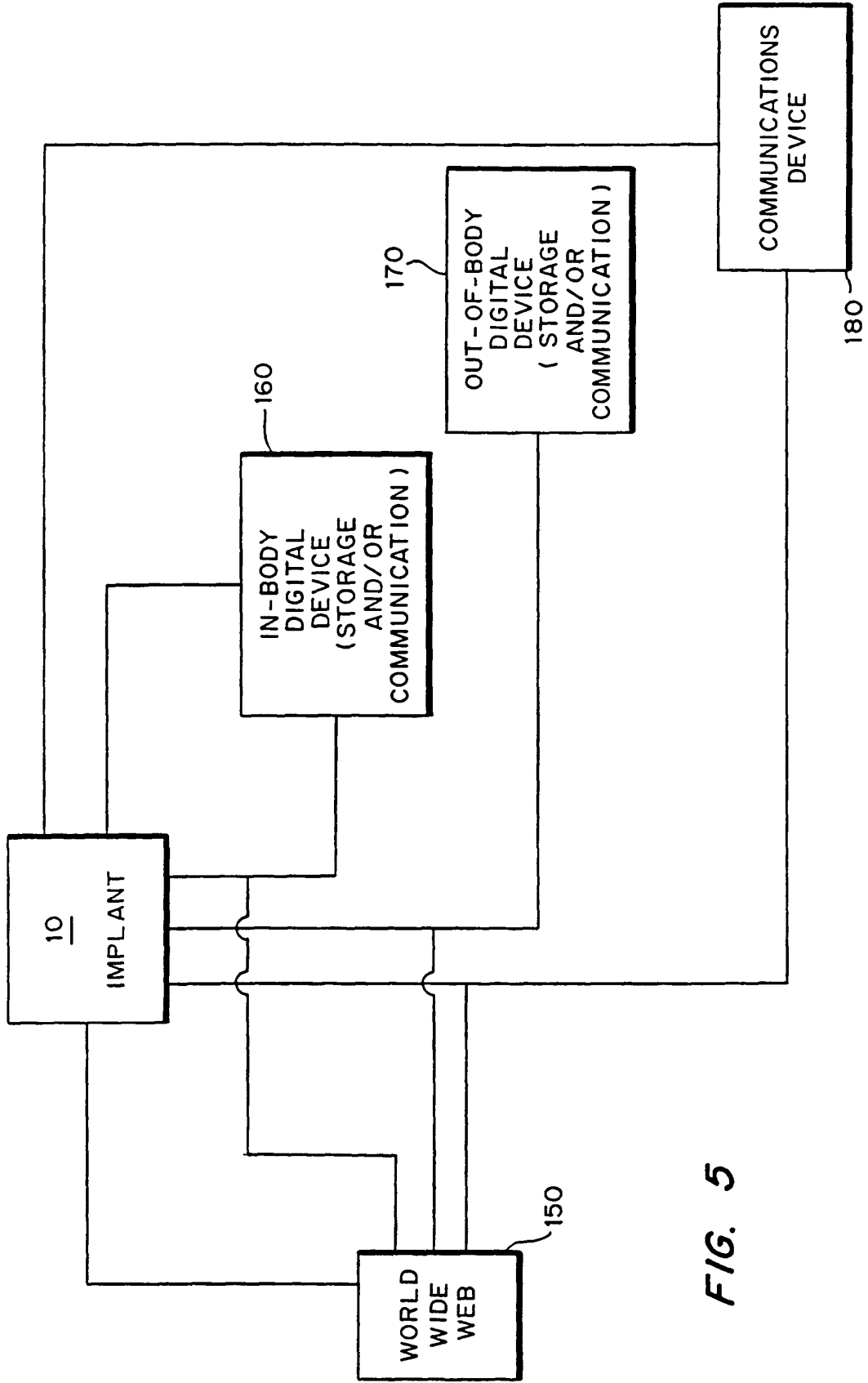

FIG. 5

REFERENCES CITED IN THE DESCRIPTION

This list of references cited by the applicant is for the reader's convenience only. It does not form part of the European patent document. Even though great care has been taken in compiling the references, errors or omissions cannot be excluded and the EPO disclaims all liability in this regard.

Patent documents cited in the description

- US 15463799 P [0002]
- US 5411551 A, Winston [0004] [0037]
- US 6091980 A, Squire [0004] [0031]
- EP 0850654 A, Schneider [0005]
- US 5807259 A, Cimochoowski [0005] [0033]
- US 6053873 A, Govari [0005] [0037]
- US 6015387 A, Schwartz [0005]
- US 5833603 A, Kovacs [0005] [0033] [0035] [0049]
- US 5709225 A, Budgifvars [0005] [0033] [0036]
- US 5928248 A, Acker [0005]
- US 5544651 A [0009] [0011] [0011]
- US 5833623 A [0012] [0013]
- WO 9221307 A [0014] [0015] [0015]
- US 5769893 A [0016] [0017] [0018]
- US 5759893 A [0018]
- US 5807258 A [0033] [0041]
- US 5865972 A [0037]
- US 5898004 A [0037]
- US 5883310 A [0037]
- US 5511428 A [0037]
- US 5512882 A [0037]
- US 5526703 A [0037]
- US 5536963 A [0037] [0044]
- EP 0850654 A1 [0037]
- US 5797898 A, Santini [0038] [0063]
- WO 9964580 A [0038]

专利名称(译)	传感, 询问, 存储, 遥测和响应医疗植入物		
公开(公告)号	EP1215994B1	公开(公告)日	2007-07-25
申请号	EP2000961948	申请日	2000-09-15
[标]申请(专利权)人(译)	腔内治疗学		
申请(专利权)人(译)	腔内治疗学, INC.		
当前申请(专利权)人(译)	腔内治疗学, INC.		
[标]发明人	SLEPIAN MARVIN J		
发明人	SLEPIAN, MARVIN, J.		
IPC分类号	A61B5/00 A61B5/0205 A61B5/0215 A61B5/026 A61B5/145 A61F2/84		
CPC分类号	A61B5/02055 A61B5/0031 A61B5/02007 A61B5/0215 A61B5/026 A61B5/145 A61B5/14539		
优先权	60/154637 1999-09-17 US		
其他公开文献	EP1215994A1		
外部链接	Espacenet		

摘要(译)

植入物, 包括响应于压力, 流体流动, 分析物浓度, pH和其他变量的传感器, 包括反馈回路和用于响应于使用传感器进行的测量而放置在患者体内后修改植入物的装置。来自传感器信号的反馈可能需要改变, 例如在血管直径随时间变化或植入物变得不稳定或迁移的情况下植入物的扩张。在另一个实施方案中, 植入物含有生物活性, 预防性, 诊断性或pH调节剂, 其中植入物由温度或pH响应性材料形成, 使得当温度或pH改变时释放药剂。这些系统还可用于将患者连接到远程数据存储系统, 例如因特网或可通过诸如PDA (Palm Pilot系统), 电话系统设备之类的设备访问的计算机, 医生可以使用这些设备与远程数据存储系统远程交互。注入。

FIG. 1

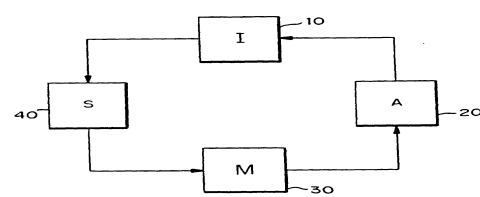

FIG. 3

