



(51) International Patent Classification:

A61B 5/00 (2006.01) C12Q 1/00 (2006.01)
A61B 5/055 (2006.01) G06F 19/00 (2011.01)
A61B 6/00 (2006.01) A61B 18/04 (2006.01)
A61B 8/00 (2006.01)

(21) International Application Number:

PCT/CA2014/050355

(22) International Filing Date:

8 April 2014 (08.04.2014)

(25) Filing Language:

English

(26) Publication Language:

English

(30) Priority Data:

61/809,521 8 April 2013 (08.04.2013) US

(71) Applicant: SUNNYBROOK RESEARCH INSTITUTE

[CA/CA]; 2075 Bayview Avenue, Toronto, Ontario M4N 3M5 (CA).

(72) Inventors: SWAMINATHAN, Venkat R.; 7 St. Dennis

Drive, Apt. 308, Toronto, Ontario M3C 1E4 (CA). CE-LIK, Haydar; 24 Wellesley Street West, Suite 1608, Toronto, Ontario M4Y 2X6 (CA). WRIGHT, Graham A.; 34 Albemarle Avenue, Toronto, Ontario M4K 1H7 (CA).

(74) Agent: HILL & SCHUMACHER; 264 Avenue Road,

Toronto, Ontario M4V 2G7 (CA).

(81) Designated States (unless otherwise indicated, for every

kind of national protection available): AE, AG, AL, AM, AO, AT, AU, AZ, BA, BB, BG, BH, BN, BR, BW, BY, BZ, CA, CH, CL, CN, CO, CR, CU, CZ, DE, DK, DM, DO, DZ, EC, EE, EG, ES, FI, GB, GD, GE, GH, GM, GT, HN, HR, HU, ID, IL, IN, IR, IS, JP, KE, KG, KN, KP, KR, KZ, LA, LC, LK, LR, LS, LT, LU, LY, MA, MD, ME, MG, MK, MN, MW, MX, MY, MZ, NA, NG, NI, NO, NZ, OM, PA, PE, PG, PH, PL, PT, QA, RO, RS, RU, RW, SA, SC, SD, SE, SG, SK, SL, SM, ST, SV, SY, TH, TJ, TM, TN, TR, TT, TZ, UA, UG, US, UZ, VC, VN, ZA, ZM, ZW.

(84) Designated States (unless otherwise indicated, for every

kind of regional protection available): ARIPO (BW, GH, GM, KE, LR, LS, MW, MZ, NA, RW, SD, SL, SZ, TZ, UG, ZM, ZW), Eurasian (AM, AZ, BY, KG, KZ, RU, TJ, TM), European (AL, AT, BE, BG, CH, CY, CZ, DE, DK, EE, ES, FI, FR, GB, GR, HR, HU, IE, IS, IT, LT, LU, LV, MC, MK, MT, NL, NO, PL, PT, RO, RS, SE, SI, SK, SM, TR), OAPI (BF, BJ, CF, CG, CI, CM, GA, GN, GQ, GW, KM, ML, MR, NE, SN, TD, TG).

Published:

- with international search report (Art. 21(3))
- before the expiration of the time limit for amending the claims and to be republished in the event of receipt of amendments (Rule 48.2(h))

(54) Title: SYSTEM AND METHOD FOR IMAGING BIOMARKERS INDICATIVE OF CARDIAC THERMAL ABLATION LESIONS

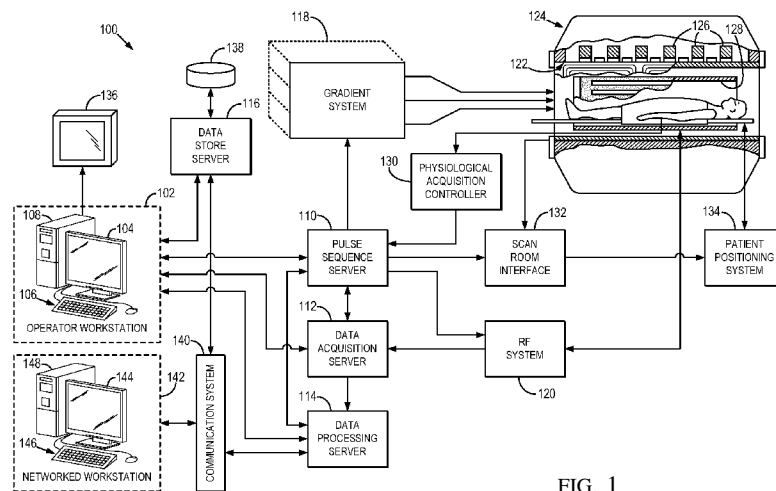

FIG. 1

(57) Abstract: -19- SYSTEM AND METHOD FOR IMAGING BIOMARKERS INDICATIVE OF CARDIAC THERMAL ABLATION LESIONS ABSTRACT OF THE DISCLOSURE Described here are systems and methods for visualizing thermal ablation lesions by imaging specific chemical compounds that are created during thermal ablation procedures, such as cardiac ablation procedures. When a cardiac ablation procedure is performed, a central area of coagulative necrosis is created at the treatment site. This necrotic region is surrounded by layers of tissues with ultra-structural and electrophysiological changes. Two particular changes include the denaturation of proteins and the formation of ferric iron containing chemical compounds, such as methemoglobin and metmyoglobin. The formation of and distribution of such chemical compounds can be imaged with the appropriate systems and methods. Accordingly, these chemical compounds can be utilized as biomarkers that indicate the presence and physical characteristics of thermal ablation lesions. Imaging can be performed using magnetic resonance imaging, optical imaging, or photoacoustic imaging, as examples.



**SYSTEM AND METHOD FOR IMAGING BIOMARKERS INDICATIVE OF CARDIAC
THERMAL ABLATION LESIONS**

CROSS-REFERENCE TO RELATED APPLICATIONS

[0001] This application claims the benefit of U.S. Provisional Patent Application Serial No. 61/809,521, filed on April 8, 2013, and entitled "SYSTEM AND METHOD FOR IMAGING BIOMARKERS INDICATIVE OF CARDIAC THERMAL ABLATION LESIONS."

BACKGROUND OF THE INVENTION

[0002] The field of the invention is systems and methods for visualizing the effect of thermal ablation on cardiac tissue using a medical imaging system. More particularly, the invention relates to systems and methods for imaging specific biomarkers that indicate the effects of thermal ablation on cardiac tissue using a medical imaging system.

[0003] Catheter ablation therapies have become the first line of treatment for many cardiac arrhythmias. These procedures are traditionally performed under the guidance of x-ray fluoroscopy and involve guiding catheters to a region-of-interest in the subject's heart. Targeted energy is then used to ablate cardiac tissue in order to interrupt conduction in the region-of-interest, thereby mitigating the arrhythmia. Commonly, a 500 kHz radiofrequency ("RF") current is used as the energy source; however, other energy sources can be used in the alternative, including laser, ultrasound, microwave, and cryotherapy. For some complex arrhythmias, such as atrial fibrillation, exclusive use of x-ray fluoroscopy guidance results in high recurrence rates, mainly due to the difficulty in visualizing soft-tissue cardiovascular organs. Other imaging modalities such as magnetic resonance imaging ("MRI"), computed tomography ("CT"), and intra-cardiac echocardiography have been investigated to improve outcomes.

[0004] The most common cause of high recurrence rates is inadequate energy delivery, which results in an insufficient lesion volume. Inadequate energy delivery can be caused by a lack of proper contact between the ablation electrode and the cardiac wall. Difficulties visualizing the soft tissues of the heart with x-ray imaging is one such source for the inadequate contact between the ablation electrode and cardiac wall. Inadequate contact can also happen due to edema, which reduces contact between the electrode and the heart wall. Other phenomena such as blood flow, which induces

convective cooling, and the formation of coagulum around the electrode, which results in high impedance, also reduce the effective delivery of RF energy to tissue.

[0005] It follows that if ablation sites can be adequately monitored for effective lesion formation, recurrence rates and clinical outcomes can be significantly improved. Lesion assessment can happen either in real-time, in which the tissue is monitored while applying the RF energy, or just after ablation, in which the assessment is done after the procedure to verify the lesions. Lesion assessment can also be combined with a feedback loop to control the application of energy or to redo the ablation depending on the monitoring data.

[0006] In general, there are two types of lesion assessment: indirect assessment by monitoring the temperature of the electrode tip or the electrode-tissue contact, and direct assessment by imaging the ablated tissue itself. Common indirect assessment techniques include using robotic or magnetic catheter navigation systems, and performing temperature or force detection using sensors in the catheter tip. These indirect methods look at changes in tissue impedance, electrogram voltage, temperature of the tip, and contact force. By monitoring one or more of these parameters, good electrode tip contact with the tissue can be ensured. Indirect methods, however, are sensitive to multiple tissue changes beyond those directly reflecting thermal damage, including the frequent presence of edema and flow, which affect RF energy delivery even with good contact. Therefore, these indirect methods cannot be used to ensure adequate tissue ablation.

[0007] Direct assessment methods attempt to address these drawbacks. Common direct assessment methods include measuring tissue temperature using MR thermometry, which monitors tissue temperature using proton-resonant frequency ("PRF"), or temperature sensitive contrast agents. These direct methods, however, can only be performed during ablation and not after. Without a persistent indicator of damage, it is difficult to track the full extent of multiple lesions created over an extended period of time. Alternatively, tissue response, such as edema and flow disruption, can be imaged with methods, including those that characterize the dynamics and distribution of various contrast agents. These changes vary with time, even within the study period, and may not be sufficiently sensitive to identify the full extent of thermal damage. As such, these changes are not reliable indicators of adequate tissue ablation.

SUMMARY OF THE INVENTION

[0008] The present invention overcomes the aforementioned drawbacks by providing systems and methods for directly assessing cardiac thermal ablation procedures using specific properties of the ablated tissue to visualize and verify the ablation sites. The systems and methods work well even in the presence of edema and flow and have good contrast and signal-to-noise to be used in different modes for ablation treatment of cardiac arrhythmia.

[0009] It is an aspect of the invention to provide a method for imaging a biomarker indicative of thermal ablation using a medical imaging system. Data is acquired with the medical imaging system and from the data an image that depicts a biomarker indicative of a thermal ablation is produced.

[0010] The foregoing and other aspects and advantages of the invention will appear from the following description. In the description, reference is made to the accompanying drawings which form a part hereof, and in which there is shown by way of illustration a preferred embodiment of the invention. Such embodiment does not necessarily represent the full scope of the invention, however, and reference is made therefore to the claims and herein for interpreting the scope of the invention.

BRIEF DESCRIPTION OF THE DRAWINGS

[0011] FIG. 1 is a block diagram of an example of a magnetic resonance imaging ("MRI") system that can implement some embodiments of the present invention;

[0012] FIG. 2 is a block diagram of an example of an optical spectrometer system that can be configured to perform diffuse reflectance spectroscopy or Raman spectroscopy, and that can implement some embodiments of the present invention; and

[0013] FIG. 3 is a block diagram of an example of a photoacoustic imaging system that can implement some embodiments of the present invention.

DETAILED DESCRIPTION OF THE INVENTION

[0014] Described here are systems and method for visualizing thermal ablation lesions by imaging specific chemical compounds that are created during thermal ablation procedures, such as cardiac ablation procedures. When a cardiac ablation procedure, or other thermal ablation procedure, is performed, a central area of coagulative necrosis is created at the treatment site. This necrotic region is surrounded by layers of tissues with ultra-structural and electrophysiological changes. Particular

changes include the denaturation of proteins and the formation of chemical compounds containing ferric iron, such as methemoglobin and metmyoglobin. For instance, tissue proteins are denatured when they are heated above 140° F /60° C, and hemoglobin is converted to methemoglobin when blood is heated. The systems and methods of the present invention thus visualize the formation of and distribution of chemical compounds such as denatured proteins and chemical compounds containing ferric iron in ablated tissues. Accordingly, these chemical compounds can be referred to as thermal ablation markers that indicate the presence of thermal ablation lesions.

[0015] The thermal ablation markers can be detected based on measurable physical properties of the chemical compounds, including their magnetic resonance, optical absorbance, and optical reflectance properties. As one example, the presence of these chemical compounds can alter magnetic resonance signal parameters, including steady-state longitudinal magnetization, M_0 ; longitudinal relaxation time, T_1 ; and transverse relaxation time, T_2 . As another example, optical absorbance or reflectance at specific wavelengths can be altered by the presence of these chemical compounds.

[0016] Some of these direct methods, such as methods based on T_1 relaxation, are modified from those developed for other organs, like liver and brain, whose physiology is very different from the heart. There is significant flow and motion in the heart and the development of edema in and around the area of ablation affects accurate visualization of the ablation site.

[0017] Multiple different imaging modalities can be used to visualize the markers, including magnetic resonance imaging ("MRI"), diffuse reflectance spectroscopy, Raman spectroscopy, and photoacoustic imaging. Using MRI, it is an advantage that both edema and the actual ablation area can be detected and differentiated. The optical and acoustic imaging modalities can be implemented for *in vivo* applications by using an appropriately designed intravascular catheter.

[0018] Turning first to MRI applications, the present invention allows for edema and cardiac thermal ablation lesions to be distinguished and visualized separately *in vivo* without the injection of a contrast agent. Prior imaging methods based on intrinsic contrast primarily used only T_2 weighting, which highlighted edema. Thus, cardiac edema was used as a marker for ablation, which is not strictly valid, as discussed above.

[0019] Methods that rely in the intrinsic contrast of T_1 -weighting have largely

not been investigated to date. When a Z_1' -weighted imaging method has been used to assess thermal ablation procedures, it was found that it closely matched T_2 -weighted imaging, as described by T. Dickfield, et al., in "Characterization of acute and subacute radiofrequency ablation lesions with nonenhanced magnetic resonance imaging," *Heart Rhythm*, 2007; 4:208-214. It is a discovery of the present invention that Z_1' weighting provides significantly different information than T_2 weighting as they relate to visualizing thermal ablations. For instance, it is a discovery of the present invention that while T_2 weighting appropriately depicts edema, Z_1' weighting visualizes the actual ablation lesion. These differences provide a choice of imaging sequences to depict different characteristics thermal ablation sites. Using the systems and methods described here, thermal ablation lesions can be visualized as early as a few minutes after an ablation treatment.

[0020] Proteins in cardiac tissue are denatured when heated and thus have a shortened longitudinal relaxation time, T_1 , relative to proteins that are not denatured. Chemical compounds containing ferric iron, such as methemoglobin or metmyoglobin, which are generated when cardiac tissue is heated during a thermal ablation procedure, effectively act as intrinsic paramagnetic contrast agents by shortening the T_1 relaxation time of nearby tissues. It follows that a Z_1' -weighted imaging method can be used to produce an image that depicts a contrast influenced by and indicating the presence of denatured proteins and chemical compounds containing ferric iron produced during a cardiac thermal ablation procedure. Such an imaging method can thus provide a visualization of the actual area of lesion generated during the cardiac thermal ablation procedure. Methods with inversion recovery or saturation preparation can be used to enhance the T_1 -weighting of the desired images of the subject. These magnetization preparation modules can be combined with either a gradient-echo ("GRE") pulse sequences, with or without spoiling; or a steady-state free precession ("SSFP") pulse sequence.

[0021] Both GRE and SSFP can be performed in a segmented manner to achieve good signal-to-noise ratio ("SNR") within a single breath hold. To monitor lesion formation in real-time during a cardiac thermal ablation procedure, however, a snapshot inversion-prepared SSFP technique is particularly effective because it can

produce a T_1 -weighted image in a single heartbeat.

[0022] The above techniques can be extended as three dimensional acquisitions for volume coverage of the ablation extent. These are particularly helpful for verifying the lesion area and identifying gaps in lesions after the ablation procedure with a high isotropic spatial resolution. When the acquisition time becomes too high to fit in a single breath hold, they can be used with respiratory-motion compensation techniques like navigators. To reduce the time of acquisition, these can also be combined with undersampled reconstruction techniques like parallel imaging or compressed sensing.

[0023] When the ablation procedure is repeated after a few weeks or months, perhaps due to recurrence of arrhythmia, there is a clinical need to differentiate between newly-created acute lesions and chronic lesions. The above-mentioned imaging techniques can be implemented to this end. For instance, over days to weeks, ferric iron and/or denatured proteins produced in response to a thermal ablation procedure will be removed by macrophages. As a result of these chemical compounds being removed from the treated sites, the presence of these chemical compounds will be diminished in chronic lesions. Methods that image the distribution of paramagnetic contrast agents, such as gadolinium-based contrast agents, can be used to produce images with contrast that is sensitive to the fibrosis seen in chronic thermal ablation lesions. A T_1 -mapping technique can also be used to provide this information. For example, the following T_1 mapping techniques for the heart can be used to this end: MOLLI, described by D.R. Messroghli, et al., in , "Modified Look-Locker inversion recovery (MOLLI) for high-resolution T_1 mapping of the heart," *Magnetic Resonance in Medicine*, 2004; 52:141-146; shMOLLI, described by S.K. Piechnik, et al., in "Shortened Modified Look-Locker Inversion recovery (ShMOLLI) for clinical myocardial T_1 -mapping at 1.5 and 3 T within a 9 heartbeat breathhold," *Journal of Cardiovascular Magnetic Resonance*, 2010; 12, 69; and MLLSR, described by T. Song, et al., in "Flexible cardiac T_1 mapping using a modified look-locker acquisition with saturation recovery," *Magnetic Resonance in Medicine*, 2012; 67:622-627.

[0024] In addition to delineating the actual ablation area, it is desirable to be able to visualize edema because edema frequently interferes with effective RF ablation delivery. In these situations, T_2 -weighted or T_2 mapping techniques can be used. T_2 -weighted techniques, such as a black-blood triple inversion-recovery sequence,

highlight regions of edema due to their enhanced T_2 weighting. A T_2 mapping technique, in addition, can be used to quantify edema and to characterize edema progression over time.

[0025] If z_1' -weighted ablation visualization methods and T_2 -weighted edema mapping methods are employed separately in different breath holds, there is a chance of misregistration between them due to different breath holding positions. A simultaneous z_1' and T_2 weighted (or mapping) sequence in the same breath hold wouldn't have this effect. An example of such a sequence is inversion-prepared CINE SSFP imaging, where a CINE sequence is modified with the application of an inversion pulse every few heartbeats, such as the one described by J.S. Detsky, et al., in "Inversion-recovery-prepared SSFP for cardiac-phase-resolved delayed-enhancement MRI," *Magnetic Resonance in Medicine*, 2007; 58:365-372. The signal evolution in the IR-SSFP CINE sequence is characterized by the T_1^* relaxation time, which is dependent on both z_1' and T_2 . Different temporal phases of this sequence have different T_1/T_2 weightings. Another example is the T_2 mapping sequence itself, where the fitted M_0 and T_2 terms can be used for T_1 -weighting and T_2 -weighting, respectively.

[0026] It should be noted that all of the above techniques do not require the administration of gadolinium-based MRI contrast agents, though they do work after the administration of contrast. After a contrast dose, the T_1 values will primarily be dependent on the local contrast agent distribution of the tissues.

[0027] T_2 mapping can be performed using a multi-echo fast-spin-echo ("MEFSE") sequence and T_1^* characterization using a 2RR-IR-SSFP CINE method. As an example, both MEFSE and IRSSFP can be performed soon after the creation of thermal ablation lesions.

[0028] MEFSE images were fitted using a standard 2-parameter fit for M_0 and T_2 ,

$$S = M_0 e^{-\frac{TE}{T_2}} \quad (1).$$

[0029] The M_0 term here is a function of both true equilibrium M_0 and T_1 because it was a single-RR (RR=700 ms) sequence. IR-SSFP signal recovery is

determined by T_1^* , which as noted above is dependent on both T_1 and T_2 . The T_2 and M_0 maps and IR-SSFP images can be analyzed using an ROI based analysis to compare the signal in three zones: an ablation lesion zone, an adjacent edema zone, and a remote tissue zone.

[0030] On T_2 maps, there is a broad area of increased T_2 in and around the ablation, likely due to edema, that is much larger than the actual extent of the lesion. However the M_0 maps correspond closely with the actual border of ablation. Contrast in T_1^* -weighted IR-SSFP images also clearly depicts the actual border of the ablation, with the ablation zone reflecting a significantly shorter T_1^* . Two phases in the IR-SSFP images, one that visualizes edema and one that visualizes actual ablation lesion, can be selected. Phases soon after the inversion pulse (inversion time 100 to 150 ms] visualize edema and later phases which have dark blood (inversion time 600 to 800 ms] visualize the ablation lesion.

[0031] The M_0 and T_2 maps appear to depict actual lesion area and edema respectively. T_1^* -weighted IR-SSFP generally gives more robust visualization of the ablation lesion within a breath-hold. It is contemplated that the high signal of the lesion core in T_1^* -weighted and T_x^* -weighted images is due to denaturation of proteins and formation of chemical compounds containing ferric iron, such as methemoglobin and metmyoglobin, which are created upon heating blood. In summary, T_1^* -weighting seems to delineate the acute lesion core while T_2 -weighting seems to depict the overlying edema. Combinations of these images can thus be used to differentially visualize edema and lesions caused by thermal ablation.

[0032] Referring particularly now to FIG. 1, an example of a magnetic resonance imaging ("MRI") system 100 is illustrated. The MRI system 100 includes an operator workstation 102, which will typically include a display 104; one or more input devices 106, such as a keyboard and mouse; and a processor 108. The processor 108 may include a commercially available programmable machine running a commercially available operating system. The operator workstation 102 provides the operator interface that enables scan prescriptions to be entered into the MRI system 100. In general, the operator workstation 102 maybe coupled to four servers: a pulse sequence

server 110; a data acquisition server 112; a data processing server 114; and a data store server 116. The operator workstation 102 and each server 110, 112, 114, and 116 are connected to communicate with each other. For example, the servers 110, 112, 114, and 116 may be connected via a communication system 140, which may include any suitable network connection, whether wired, wireless, or a combination of both. As an example, the communication system 140 may include both proprietary or dedicated networks, as well as open networks, such as the internet.

[0033] The pulse sequence server 110 functions in response to instructions downloaded from the operator workstation 102 to operate a gradient system 118 and a radiofrequency ("RF") system 120. Gradient waveforms necessary to perform the prescribed scan are produced and applied to the gradient system 118, which excites gradient coils in an assembly 122 to produce the magnetic field gradients G_x , G_y , and G_z used for position encoding magnetic resonance signals. The gradient coil assembly 122 forms part of a magnet assembly 124 that includes a polarizing magnet 126 and a whole-body RF coil 128.

[0034] RF waveforms are applied by the RF system 120 to the RF coil 128, or a separate local coil (not shown in FIG. 1), in order to perform the prescribed magnetic resonance pulse sequence. Responsive magnetic resonance signals detected by the RF coil 128, or a separate local coil (not shown in FIG. 1), are received by the RF system 120, where they are amplified, demodulated, filtered, and digitized under direction of commands produced by the pulse sequence server 110. The RF system 120 includes an RF transmitter for producing a wide variety of RF pulses used in MRI pulse sequences. The RF transmitter is responsive to the scan prescription and direction from the pulse sequence server 110 to produce RF pulses of the desired frequency, phase, and pulse amplitude waveform. The generated RF pulses may be applied to the whole-body RF coil 128 or to one or more local coils or coil arrays (not shown in FIG. 1).

[0035] The RF system 120 also includes one or more RF receiver channels. Each RF receiver channel includes an RF preamplifier that amplifies the magnetic resonance signal received by the coil 128 to which it is connected, and a detector that detects and digitizes the I and Q quadrature components of the received magnetic resonance signal. The magnitude of the received magnetic resonance signal may, therefore, be determined at any sampled point by the square root of the sum of the squares of the I

and Q components:

$$M = \sqrt{I^2 + Q^2} \quad (2);$$

[0036] and the phase of the received magnetic resonance signal may also be determined according to the following relationship:

$$\varphi = \tan^{-1}\left(\frac{Q}{I}\right) \quad (3).$$

[0037] The pulse sequence server 110 also optionally receives patient data from a physiological acquisition controller 130. By way of example, the physiological acquisition controller 130 may receive signals from a number of different sensors connected to the patient, such as electrocardiograph ("ECG") signals from electrodes, or respiratory signals from a respiratory bellows or other respiratory monitoring device. Such signals are typically used by the pulse sequence server 110 to synchronize, or "gate," the performance of the scan with the subject's heart beat or respiration.

[0038] The pulse sequence server 110 also connects to a scan room interface circuit 132 that receives signals from various sensors associated with the condition of the patient and the magnet system. It is also through the scan room interface circuit 132 that a patient positioning system 134 receives commands to move the patient to desired positions during the scan.

[0039] The digitized magnetic resonance signal samples produced by the RF system 120 are received by the data acquisition server 112. The data acquisition server 112 operates in response to instructions downloaded from the operator workstation 102 to receive the real-time magnetic resonance data and provide buffer storage, such that no data is lost by data overrun. In some scans, the data acquisition server 112 does little more than pass the acquired magnetic resonance data to the data processor server 114. However, in scans that require information derived from acquired magnetic resonance data to control the further performance of the scan, the data acquisition server 112 is programmed to produce such information and convey it to the pulse sequence server 110. For example, during prescans, magnetic resonance data is acquired and used to calibrate the pulse sequence performed by the pulse sequence server 110. As another example, navigator signals may be acquired and used to adjust the operating parameters of the RF system 120 or the gradient system 118, or to control the view order in which k-space is sampled. In still another example, the data

acquisition server 112 may also be employed to process magnetic resonance signals used to detect the arrival of a contrast agent in a magnetic resonance angiography ("MRA") scan. By way of example, the data acquisition server 112 acquires magnetic resonance data and processes it in real-time to produce information that is used to control the scan.

[0040] The data processing server 114 receives magnetic resonance data from the data acquisition server 112 and processes it in accordance with instructions downloaded from the operator workstation 102. Such processing may, for example, include one or more of the following: reconstructing two-dimensional or three-dimensional images by performing a Fourier transformation of raw k-space data; performing other image reconstruction algorithms, such as iterative or backprojection reconstruction algorithms; applying filters to raw k-space data or to reconstructed images; generating functional magnetic resonance images; calculating motion or flow images; and so on.

[0041] Images reconstructed by the data processing server 114 are conveyed back to the operator workstation 102 where they are stored. Real-time images are stored in a data base memory cache (not shown in FIG. 1), from which they may be output to operator display 112 or a display 136 that is located near the magnet assembly 124 for use by attending physicians. Batch mode images or selected real time images are stored in a host database on disc storage 138. When such images have been reconstructed and transferred to storage, the data processing server 114 notifies the data store server 116 on the operator workstation 102. The operator workstation 102 may be used by an operator to archive the images, produce films, or send the images via a network to other facilities.

[0042] The MRI system 100 may also include one or more networked workstations 142. By way of example, a networked workstation 142 may include a display 144; one or more input devices 146, such as a keyboard and mouse; and a processor 148. The networked workstation 142 may be located within the same facility as the operator workstation 102, or in a different facility, such as a different healthcare institution or clinic.

[0043] The networked workstation 142, whether within the same facility or in a different facility as the operator workstation 102, may gain remote access to the data processing server 114 or data store server 116 via the communication system 140.

Accordingly, multiple networked workstations 142 may have access to the data processing server 114 and the data store server 116. In this manner, magnetic resonance data, reconstructed images, or other data may be exchanged between the data processing server 114 or the data store server 116 and the networked workstations 142, such that the data or images may be remotely processed by a networked workstation 142. This data may be exchanged in any suitable format, such as in accordance with the transmission control protocol ("TCP"), the internet protocol ("IP"), or other known or suitable protocols.

[0044] Because the z_1' -weighted imaging signal change is primarily caused by the creation of denatured proteins and chemical compounds containing ferric iron, including methemoglobin and metmyoglobin, during ablation, other imaging modalities based on the optical or acoustic properties of these chemical compounds can be used to detect thermal ablations as well. As an example, optical properties of methemoglobin or metmyoglobin can be exploited by incorporating optical detection techniques into catheters for intracardiac use.

[0045] The heme group of methemoglobin and metmyoglobin contains ferric iron (Fe^{3+}), instead of ferrous iron (Fe^{2+}), which is found in oxyhemoglobin, deoxyhemoglobin, and myoglobin. This makes methemoglobin and metmyoglobin detectable using optical or acoustic techniques.

[0046] Methemoglobin formed in skin ablation lesions created by a pulsed dye laser has been detected using diffuse reflectance spectroscopy ("DRS") in the visible to near-infrared spectrum. A similar setup with a hand-held fiber-optic surface probe connected to a spectrometer was used in measuring myocardial tissue oxygenation during coronary artery bypass graft surgery. Another related technique, broadband diffuse optical spectroscopy has been used to monitor in-vivo methemoglobin formation in the blood non-invasively. Using similar equipment suitably modified for cardiac catheterization, methemoglobin and metmyoglobin created during cardiac ablations can be detected using visible to near-infrared spectroscopy.

[0047] Raman spectroscopy has also been found to detect methemoglobin. More recently, it has been found to detect methemoglobin in whole blood or even in a single red blood cell. Fiber-optic probes have been developed for Raman spectroscopy for use in gastro-intestinal applications like endoscopy. A similar probe for cardiac catheterization applications can detect methemoglobin and metmyoglobin created

during cardiac electrophysiology ablation procedures.

[0048] Referring now to FIG. 2, an example of an optical spectrometer system 200 that includes a fiber optic probe 202 is illustrated. In some embodiments, the fiber optic probe 202 can be incorporated into an intravascular or endoscopic device, such as an intravascular catheter or an endoscope. The optical spectrometer system also includes a light source 204, a spectrometer 206, an optical detector 208, and a processing unit 210. In some embodiments, the optical spectrometer system 200 may also include a monochromator that is optically coupled to the light source 204. As an example, the monochromator may include a scanning double-excitation monochromator.

[0049] The optical spectrometer system 200 can be configured to perform any number of different optical spectroscopy techniques, including diffuse reflectance spectroscopy ("DRS"), diffuse optical spectroscopy, and Raman spectroscopy.

[0050] Light, or other electromagnetic radiation, is provided by the light source 204 and communicated via an optical fiber to the fiber optic probe 202, where the light or other electromagnetic radiation is transmitted into a sample, object, or subject. As one example, the light source 204 may include a white light source, and as another example, may include a laser. Light, or other electromagnetic radiation, is received by the fiber optic probe 202 and communicated to the spectrometer 206 via an optical fiber. The fiber optic probe 202 may include at least one emitting fiber for emitting the light, or other electromagnetic radiation, into the sample, object or subject. The fiber optic probe 202 may also include at least one collecting fiber for collecting light, or other electromagnetic radiation, that has interacted with the sample, object, or subject.

[0051] The optical detector 208 is optically coupled to the spectrometer 206 and acquires data based on the light, or other electromagnetic radiation, entering the spectrometer 206 from the fiber optic probe 202. In some embodiments, the optical detector 208 may include a charged-couple device ("CCD") unit. The data acquired by the optical detector 208 is communicated to the processing unit 210 for processing, such as the generation of spectra and images of the sample, object, or subject.

[0052] As an example, the processing unit 210 includes a commercially available computer system, including a processor, a memory or other data storage device, a display, and input devices, such as a keyboard and mouse. The processing unit 210 can be configured to convert the collected electromagnetic radiation to at least one of

absorption and scattering data, from which reflectance spectra can be produced. The processing unit 210 can also be configured to convert the collected electromagnetic radiation to data from which Raman spectra can be produced.

[0053] Photoacoustic imaging is a method that delivers laser pulses to biological tissues and detects the resulting ultrasonic waves. It has recently been used to detect methemoglobin in skin lesions, and has been integrated into catheters for combined photoacoustic and intravascular ultrasound ("IVUS") imaging. Repurposing the catheters for cardiac imaging, cardiac ablation lesion creation can be detected using methemoglobin or metmyoglobin as markers.

[0054] Referring now to FIG. 3, a block diagram of an example photoacoustic imaging system 300 that incorporates an photoacoustic imaging device 302 is illustrated. The photoacoustic imaging device 302 generally includes a fiber assembly 304 and a transducer assembly 306, which may be coupled together. For instance, the fiber assembly 304 and transducer assembly 306 may be coupled via a common outer sheath that holds the fiber assembly 304 and transducer assembly 306 in spaced arrangement.

[0055] The fiber assembly 304 includes at least one optical fiber. A light source 308 is optically coupled to the fiber assembly 304 and delivers light to the distal end of the fiber assembly 304 to irradiate the object being imaged. In some embodiments, the light source 308 is a laser source, which may be a continuous wave laser source or a pulse wave laser source. In some embodiments, the light source 308 may include multiple laser systems or diodes, thereby providing different optical wavelengths, that are fed into one or more optical fibers. The selection of an appropriate excitation wavelength for the light source 308 is based on the absorption characteristics of the imaging target. Because the average optical penetration depth for intravascular tissue is on the order of several to tens of millimeters, the 400-2100 nm wavelength spectral range is suitable for intravascular photoacoustic applications. Thus, in some embodiments, the light source 308 may be an Nd:YAG (neodymium-doped yttrium aluminum garnet) laser that operates at 1064 nm wavelength in a continuous mode.

[0056] The transducer assembly 306 generally includes an photoacoustic transducer for receiving photoacoustic signals generated by an illumination field, such as an illumination field generated by pulsed or continuous wave laser light. In some configurations, the photoacoustic transducer can also be operated to generate

ultrasound energy and to receive pulse-echo ultrasound emissions. In this configuration, the photoacoustic transducer can be operated in a receive-only mode for photoacoustic imaging and, when the illumination field is not being generated, the photoacoustic transducer can also be operated in an ultrasound imaging mode to obtain ultrasound images. In some configurations, the photoacoustic transducer may include multiple transducer elements, some of which may be dedicated solely for receiving photoacoustic signals while others may be dedicated solely to generating and receiving pulse-echo ultrasound signals.

[0057] In some other configurations, the transducer assembly 306 may include at least two transducers: a dedicated photoacoustic transducer and a dedicated ultrasound transducer for generating and receiving pulse-echo ultrasound signals. In this dual-transducer configuration, both photoacoustic and ultrasound images can be obtained. With the dual-transducer configuration, photoacoustic and ultrasound images can be obtained simultaneously and, even when not obtained simultaneously, are innately co-registered given the spatial relationship between the photoacoustic transducer and the ultrasound transducer.

[0058] Irradiation with the light source 308 is performed at a given point for a finite amount of time with an optical excitation waveform. In frequency-domain photoacoustic applications, in which a continuous wave laser is used, the optical excitation waveform may be amplitude modulated with frequency sweeping, such as a chirp or pulse train. The irradiation produced by this type of optical excitation results in a frequency-domain photoacoustic modulated signal being produced in the region illuminated by the photoacoustic imaging device 302. The chirp can include a multitude of different excitation waveforms including linear, non-linear, and Gaussian tapered frequency swept chirps.

[0059] When used to obtain ultrasound images, operation of the transducer assembly 306 may be controlled by an ultrasound pulser 310, which provides ultrasound excitation waveforms to the transducer assembly 306. In single-transducer configurations in which the photoacoustic transducer is used to both receive photoacoustic signals and to generate and receive pulse-echo ultrasound signals, a delay 312 between the light source 308 and the ultrasound pulser 310 provides a trigger signal that directs the ultrasound pulser 310 to operate the photoacoustic transducer at a delay with respect to the irradiation of the field-of-view 314. The timing provided by

the delay 312 enables the detection of photoacoustic signals by the photoacoustic transducer in the transducer assembly 306 when the field-of-view 314 is being illuminated, but also the generation and detection of pulse-echo ultrasound signals when the field-of-view 314 is not being illuminated.

[0060] Signals received by the transducer assembly 306 are communicated to a receiver 316, which generally includes a pre-amplifier, but may also include one or more filters, such as bandpass filters for signal conditioning. The received signals are then communicated to a processor 318 for analysis.

[0061] Thus, the generated photoacoustic signals are detected by the photoacoustic transducer in the transducer assembly 306, communicated to the receiver 316, and then communicated to the processor 318 for processing and/or image generation. As one example, the photoacoustic signals can be processed in accordance with the methods described above to monitor the physical changes in a tissue following the administration of a treatment, such as a radiation treatment or a chemotherapy treatment. Similarly, pulse-echo ultrasound signals received by either the photoacoustic transducer or a dedicated ultrasound transducer in the transducer assembly 306 can also be communicated to the receiver 316 and then communicated to the processor 318 for processing and/or image generation.

[0062] The present invention has been described in terms of one or more preferred embodiments, and it should be appreciated that many equivalents, alternatives, variations, and modifications, aside from those expressly stated, are possible and within the scope of the invention.

CLAIMS

1. A method for imaging a biomarker indicative of thermal ablation using a medical imaging system, the steps of the method comprising:

- a) acquiring data with the medical imaging system; and
- b) producing from the acquired data, an image that depicts a biomarker indicative of a thermal ablation.

2. The method as recited in claim 1 in which the biomarker is a physical property of a chemical compound produced in response to thermal ablation.

3. The method as recited in claim 2 in which the chemical compound is at least one of a ferric iron containing chemical compound and a denatured protein.

4. The method as recited in claim 3 in which the ferric iron containing chemical compound is selected from the group consisting of methemoglobin, metmyoglobin, and combinations thereof.

5. The method as recited in claim 1 in which step a) is performed at least one of during a thermal ablation procedure and after a thermal ablation procedure.

6. The method as recited in claim 1 in which the medical imaging system is a magnetic resonance imaging system.

7. The method as recited in claim 6 in which the biomarker is a physical property of a chemical compound produced in response to thermal ablation, and the chemical compound is at least one of a ferric iron containing chemical compound and a denatured protein.

8. The method as recited in claim 7 in which the ferric iron containing chemical compound is selected from the group consisting of methemoglobin, metmyoglobin, and combinations thereof.

9. The method as recited in claim 7 in which the physical property is at least one of a longitudinal magnetization, M_0 ; a longitudinal relaxation time, T_1 ; a transverse relaxation time, T_2 ; and a relaxation time that accounts for both longitudinal and transverse relaxation, T_1^* .

10. The method as recited in claim 9 in which step b) includes producing a T_2 map having pixel values indicative of T_2 values.

11. The method as recited in claim 9 in which step b) includes producing a T_1^* map having pixel values indicative of T_1^* values.

12. The method as recited in claim 9 in which step b) includes producing a Z_1' map having pixel values indicative of Z_1' values.

13. The method as recited in claim 12 further comprising identifying a thermal ablation lesion in the T_1 map and quantifying an age of the identified thermal ablation lesion based on T_1 values at pixels locations associated with the identified thermal lesion.

14. The method as recited in claim 6 further comprising monitoring lesion formation in real-time during a cardiac thermal ablation procedure by repeatedly performing steps a) and b) using an inversion-recovery steady-state free precession pulse sequence in step a) to acquire data in a single heartbeat.

15. The method as recited in claim 1 in which the medical imaging system is an intravascular optical imaging system capable of at least one of diffuse reflectance spectroscopy, diffuse optical spectroscopy, and Raman spectroscopy.

16. The method as recited in claim 1 in which the medical imaging system is a photoacoustic imaging system.

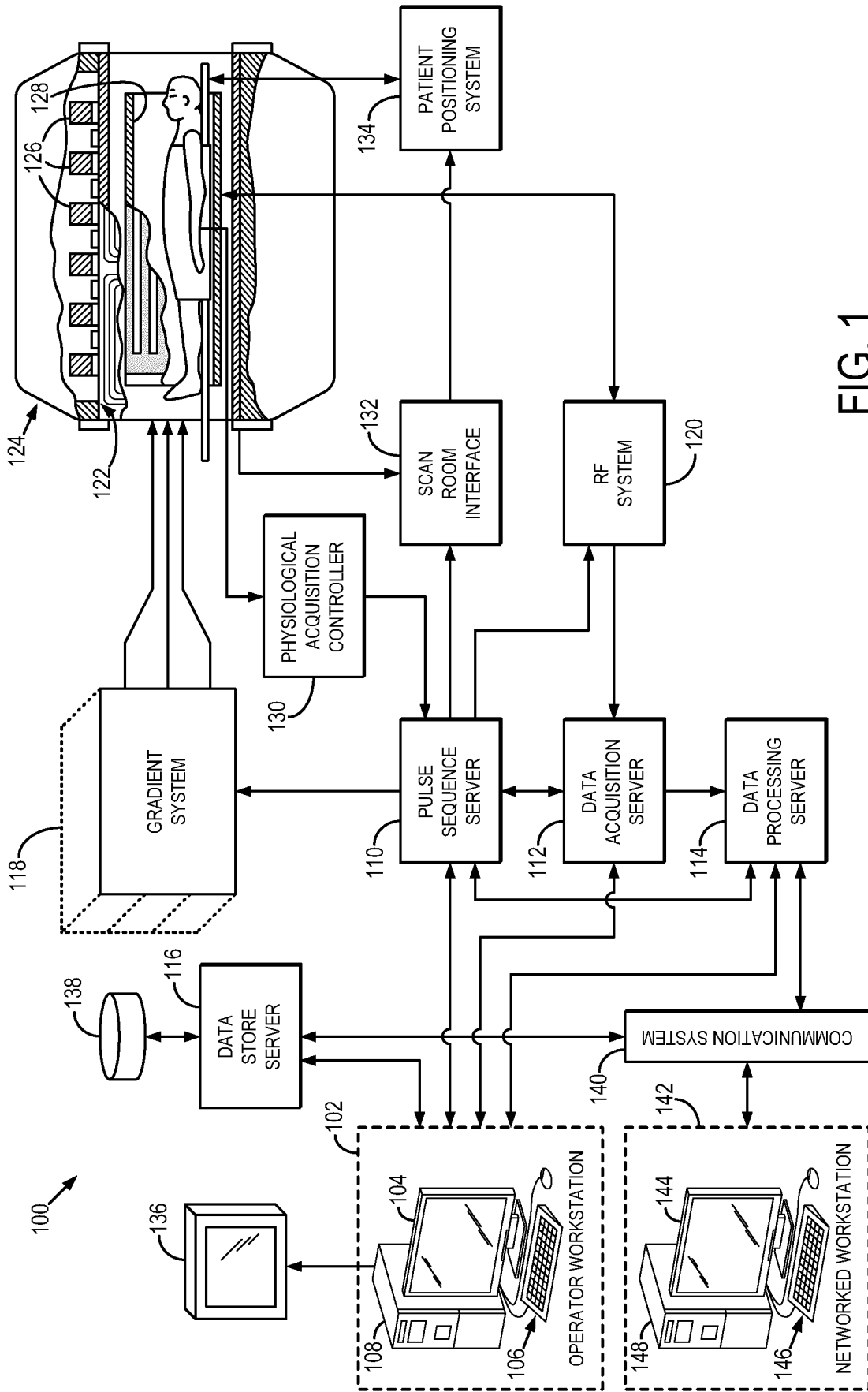

FIG. 1

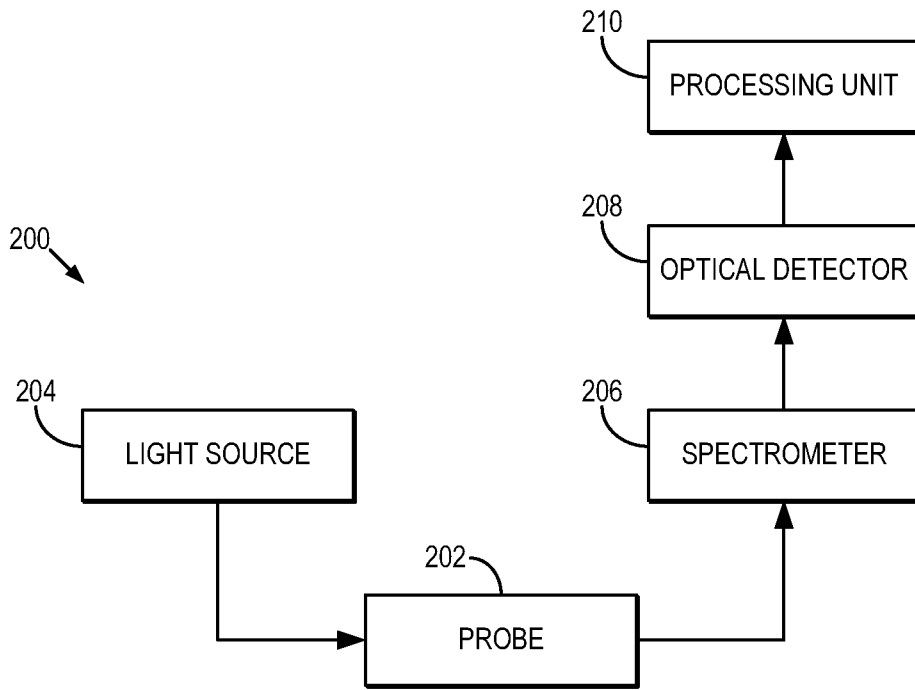

FIG. 2

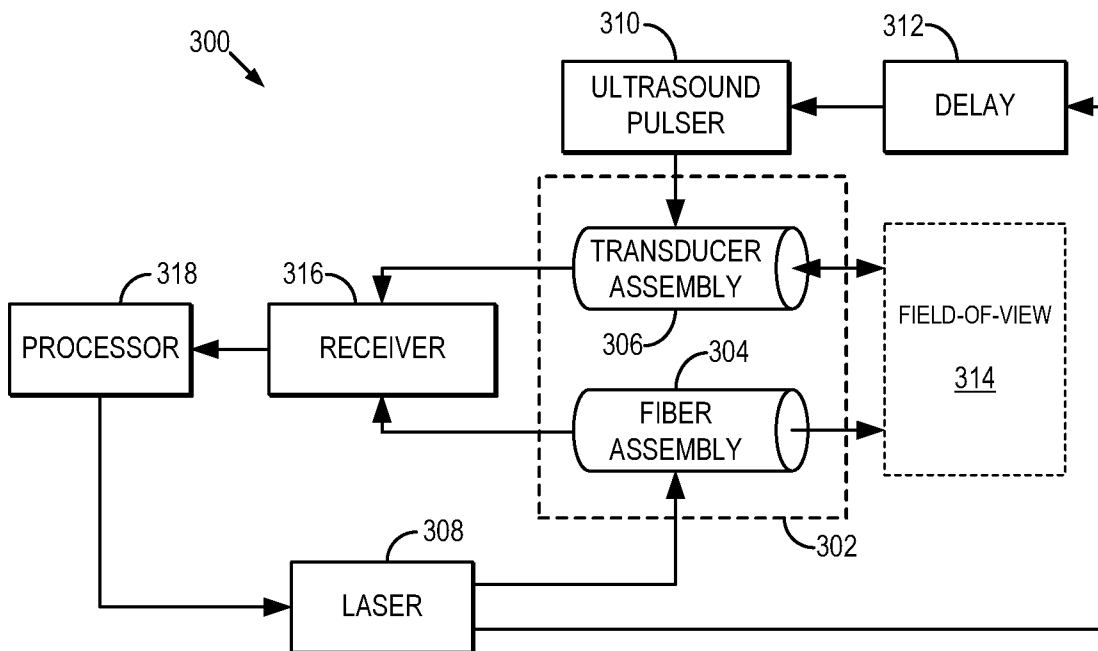

FIG. 3

INTERNATIONAL SEARCH REPORT

International application No.

PCT/CA2014/050355

A. CLASSIFICATION OF SUBJECT MATTER

IPC: *A61B 5/00* (2006.01) , *A61B 5/055* (2006.01) , *A61B 6/00* (2006.01) , *A61B 8/00* (2006.01) ,*C12Q 1/00* (2006.01) , *G06F 19/00* (201 1.01) , *A61B 18/04* (2006.01)

According to International Patent Classification (IPC) or to both national classification and IPC

B. FIELDS SEARCHED

Minimum documentation searched (classification system followed by classification symbols)

IPC: *A61B 5/00* (2006.01) , *A61B 5/055* (2006.01) , *A61B 6/00* (2006.01) , *A61B 8/00* (2006.01) ,*C12Q 1/00* (2006.01) , *G06F 19/00* (2011.01)

Documentation searched other than minimum documentation to the extent that such documents are included in the fields searched

Electronic database(s) consulted during the international search (name of database(s) and, where practicable, search terms used)

Databases: CPD (Canadian Patent Database), IEEE Xplore, Google Patents, Total Patent

Key Words: thermal, ablation, lesion, cardiac, imaging, chemical, compound, biomarker, acquire, data, medical, imaging, system

C. DOCUMENTS CONSIDERED TO BE RELEVANT

Category*	Citation of document, with indication, where appropriate, of the relevant passages	Relevant to claim No.
P (X)	WO2014082083 (A1) 30 May 2014 (30-05-2014) by Schettini et al. ** see abstract, entire application**	1-16
P (A)	WO2013134786 (A1) 12 Sept. 2013 (12-09-2013) by Pawlowski et al. ** see abstract, entire application**	1-16
A	US201001 10414 (A1) 6 May 2010 (06-05-2010) by Colice ** see abstract, entire application **	1-16

I Further documents are listed in the continuation of Box C.

See patent family annex.

* "A" "E" "L" "O" "P"	Special categories of cited documents: document defining the general state of the art which is not considered to be of particular relevance earlier application or patent but published on or after the international filing date document which may throw doubts on priority claim(s) or which is cited to establish the publication date of another citation or other special reason (as specified) document referring to an oral disclosure, use, exhibition or other means document published prior to the international filing date but later than the priority date claimed	"T" "X" "Y" "&"	later document published after the international filing date or priority date and not in conflict with the application but cited to understand the principle or theory underlying the invention document of particular relevance; the claimed invention cannot be considered novel or cannot be considered to involve an inventive step when the document is taken alone document of particular relevance; the claimed invention cannot be considered to involve an inventive step when the document is combined with one or more other such documents, such combination being obvious to a person skilled in the art document member of the same patent family
--------------------------------------	--	--------------------------	--

Date of the actual completion of the international search
04 August 2014 (04-08-2014)Date of mailing of the international search report
11 August 2014 (11-08-2014)Name and mailing address of the ISA/CA
Canadian Intellectual Property Office
Place du Portage I, CI 14 - 1st Floor, Box PCT
50 Victoria Street
Gatineau, Quebec K1A 0C9
Facsimile No.: 001-819-953-2476

Authorized officer

Karen Oprea (819) 934-2668

INTERNATIONAL SEARCH REPORT
Information on patent family members

International application No.

PCT/CA2014/050355

Patent Document Cited in Search Report	Publication Date	Patent Family Member(s)	Publication Date
WO2014082083A1	30 May 2014 (30-05-2014)	WO2014082083A1 WO2013134786A2 WO2013134786A3 WO2014068408A2	30 May 2014 (30-05-2014) 12 September 2013 (12-09-2013) 27 February 2014 (27-02-2014) 08 May 2014 (08-05-2014)
WO2013 134786A2	12 September 2013 (12-09-2013)	WO2013134786A2 WO2013134786A3 WO2014068408A2 WO2014082083A1	12 September 2013 (12-09-2013) 27 February 2014 (27-02-2014) 08 May 2014 (08-05-2014) 30 May 2014 (30-05-2014)
US20101 10414A1	06 May 2010 (06-05-2010)	US20101 10414A1 US859361 9B2 EP2274572A2 EP2274572A4 JP201 1523862A US2014206989A1 WO20091 37701 A2 WO2009137701A3	06 May 2010 (06-05-2010) 26 November 2013 (26-11-2013) 19 January 2011 (19-01-2011) 28 August 2013 (28-08-2013) 25 August 2011 (25-08-2011) 24 July 2014 (24-07-2014) 12 November 2009 (12-11-2009) 11 February 2010 (11-02-2010)

专利名称(译)	用于成像指示心脏热消融损伤的生物标记的系统和方法		
公开(公告)号	EP2983581A4	公开(公告)日	2016-12-07
申请号	EP2014782812	申请日	2014-04-08
申请(专利权)人(译)	森尼布鲁克研究所		
当前申请(专利权)人(译)	森尼布鲁克研究所		
[标]发明人	SWAMINATHAN VENKAT R CELIK HAYDAR WRIGHT GRAHAM A		
发明人	SWAMINATHAN, VENKAT R. CELIK, HAYDAR WRIGHT, GRAHAM A.		
IPC分类号	A61B5/00 A61B5/055 A61B6/00 A61B8/00 C12Q1/00 G06F19/00 A61B18/04 A61B8/08 A61B8/12 A61B18/00 A61B18/12 A61B90/00		
CPC分类号	A61B5/4836 A61B5/0044 A61B5/0084 A61B5/0095 A61B5/055 A61B8/0883 A61B8/0891 A61B8/12 A61B8/4416 A61B8/5246 A61B18/04 A61B18/12 A61B2018/00351 A61B2018/00577 A61B2018/00642 A61B2090/373 A61B2090/374 A61B2090/378 G01R33/20		
优先权	61/809521 2013-04-08 US		
其他公开文献	EP2983581A1		
外部链接	Espacenet		

摘要(译)

这里描述的是通过对在热消融过程（例如心脏消融过程）期间产生的特定化学化合物成像来可视化热消融损伤的系统和方法。当进行心脏消融手术时，在治疗部位产生凝固性坏死的中心区域。这个坏死区域被具有超结构和电生理学变化的组织层包围。两个特别的变化包括蛋白质的变性和含有三价铁的化合物的形成，例如高铁血红蛋白和高铁肌红蛋白。这些化合物的形成和分布可以用适当的系统和方法成像。因此，这些化合物可用作生物标志物，其指示热消融损伤的存在和物理特征。作为示例，可以使用磁共振成像，光学成像或光声成像来执行成像。