

(19) World Intellectual Property Organization
International Bureau



(43) International Publication Date
5 March 2009 (05.03.2009)

PCT

(10) International Publication Number
WO 2009/027917 A1

(51) International Patent Classification:

A61B 5/11 (2006.01)	G09B 19/00 (2006.01)
A61B 5/22 (2006.01)	G06F 19/00 (2006.01)
A61B 5/00 (2006.01)	A61B 5/024 (2006.01)
A63B 21/00 (2006.01)	A61B 5/021 (2006.01)
A63B 69/00 (2006.01)	A61B 5/0488 (2006.01)
A63B 69/36 (2006.01)	A61B 5/08 (2006.01)

(71) Applicant (for DE only): PHILIPS INTELLECTUAL PROPERTY & STANDARDS GMBH [DE/DE]; Lübeckertordamm 5, 20099 Hamburg (DE).

(72) Inventor; and

(75) Inventor/Applicant (for US only): LANFERMANN, Gerd [DE/DE]; c/o High Tech Campus building 44, NL-5656 AE Eindhoven (NL).

(21) International Application Number:

PCT/IB2008/053386

(74) Agents: SCHOUTEN, Marcus, M. et al.; High Tech Campus building 44, NL-5656 AE Eindhoven (NL).

(22) International Filing Date: 22 August 2008 (22.08.2008)

(25) Filing Language: English

(26) Publication Language: English

(30) Priority Data:

07114912.4 24 August 2007 (24.08.2007) EP

(81) Designated States (unless otherwise indicated, for every kind of national protection available): AE, AG, AL, AM, AO, AT, AU, AZ, BA, BB, BG, BH, BR, BW, BY, BZ, CA, CH, CN, CO, CR, CU, CZ, DE, DK, DM, DO, DZ, EC, EE, EG, ES, FI, GB, GD, GE, GH, GM, GT, HN, HR, HU, ID, IL, IN, IS, JP, KE, KG, KM, KN, KP, KR, KZ, LA, LC, LK, LR, LS, LT, LU, LY, MA, MD, ME, MG, MK, MN, MW, MX, MY, MZ, NA, NG, NI, NO, NZ, OM, PG, PH, PL, PT, RO, RS, RU, SC, SD, SE, SG, SK, SL, SM, ST, SV, SY, TJ, TM, TN, TR, TT, TZ, UA, UG, US, UZ, VC, VN, ZA, ZM, ZW.

(71) Applicant (for all designated States except DE, US): KONINKLIJKE PHILIPS ELECTRONICS N.V. [NL/NL]; Groenewoudseweg 1, NL-5621 BA Eindhoven (NL).

[Continued on next page]

(54) Title: SYSTEM AND METHOD FOR DISPLAYING ANONYMOUSLY ANNOTATED PHYSICAL EXERCISE DATA

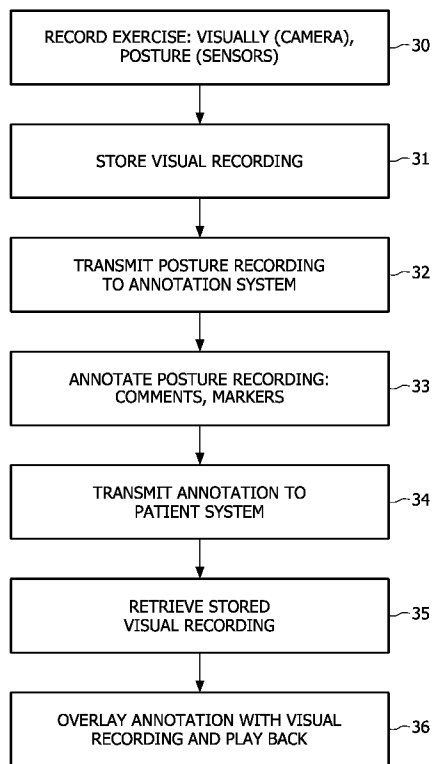

FIG. 3

(57) Abstract: The present invention relates to a method for displaying anonymously annotated physical exercise data to a person undertaking exercises. Based on physical exercise data, the physical exercise data is annotated at a physically separate annotation unit. At the location of the person, visual recordings of the person undertaking exercises together with synchronized annotation information are displayed to the person. A system for performing the method comprises a physical data processing unit (1), a display device (2), at least one posture recording device (3, 3'), a visual recording device (4), a data storage unit (5) and a physically separate annotation unit (6) in connection with the physical data processing unit (1), the connection being via an interconnected computer network (7).

WO 2009/027917 A1



(84) **Designated States** (*unless otherwise indicated, for every kind of regional protection available*): ARIPO (BW, GH, GM, KE, LS, MW, MZ, NA, SD, SL, SZ, TZ, UG, ZM, ZW), Eurasian (AM, AZ, BY, KG, KZ, MD, RU, TJ, TM), European (AT, BE, BG, CH, CY, CZ, DE, DK, EE, ES, FI, FR, GB, GR, HR, HU, IE, IS, IT, LT, LU, LV, MC, MT, NL, NO, PL, PT, RO, SE, SI, SK, TR), OAPI (BF, BJ, CF, CG, CI, CM, GA, GN, GQ, GW, ML, MR, NE, SN, TD, TG).

Declaration under Rule 4.17:

— *as to applicant's entitlement to apply for and be granted a patent (Rule 4.17(ii))*

Published:

— *with international search report*

— *before the expiration of the time limit for amending the claims and to be republished in the event of receipt of amendments*

System and method for displaying anonymously annotated physical exercise data

BACKGROUND OF THE INVENTION

The present invention relates to a system and method for displaying anonymously annotated physical exercise data to a person undertaking exercises.

Home rehabilitation exercises for persons suffering from a medical condition like a stroke or home training exercises for persons wishing to improve body motions like a golf swing can be recorded via sensors. The exercises can also be evaluated by a professional such as a physiotherapist or a golf instructor in order to give the person a direct feedback.

If the professional performing the review is not present during the exercise, video camera recordings could be sent to him. These recordings could be reviewed intuitively by the professional and the commented recordings could be understood intuitively by the person undertaking the exercise. However, these recordings, especially when sent away to a remote professional, could breach the privacy of the person. Furthermore, a completely automatic processing of such recorded images to provide meaningful feedback is a demanding task.

Alternatively, the sole transmission of data from the sensors would not violate the privacy of the person. In this respect, US 6,817,979 B2 relates to a system and method which provide for interacting with a virtual physiological model of a user with the use of a mobile communication device. Physiological data associated with the user is acquired from the user. The physiological data is transmitted to the mobile communication device, preferably with the use of a wireless communication protocol. The methodology further involves using the mobile communication device to communicate the physiological data to a network server. The physiological data is integrated into the virtual physiological model of the user. The user can access data and depictions of the user developed from the physiological data.

By way of example, a user can create an avatar representative of the current physical state of the user. The user can adjust the avatar to change the appearance of the avatar to a more desired appearance. For example, the anatomical dimensions of the avatar can be changed to reflect desired waist, chest, upper arms and thigh dimensions. Given differences between the desired avatar features and present avatar features, various training,

diet and related fitness recommendations can be developed to establish a training regimen most suited to help the user achieve the desired fitness goals. Physiological data is subsequently acquired and applied to the user's avatar, and compared to the desired avatar's data to determine if the training regimen is effective in achieving the desired fitness goals.

5 However, in general the interpretation of sensor signals in the frontend leads to difficulties on the part of the user. It is hard to relate to an abstract rendering of an artificial screen character.

 Despite this effort accordingly there still exists a need in the art for a system and a method for displaying anonymously annotated physical exercise data to a person
10 undertaking exercises.

SUMMARY OF THE INVENTION

 To achieve this and other objects the present invention is directed to a method for displaying anonymously annotated physical exercise data to a person undertaking
15 exercises, comprising the steps of:

- a) gathering physical exercise data from a person undertaking exercises;
- b) synchronously gathering visual recordings of the person undertaking exercises;
- c) transmitting the physical exercise data to a physically separate annotation unit;
- 20 d) based on the physical exercise data, annotating the physical exercise data at the physically separate annotation unit;
- e) transmitting the annotation information to a display and processing unit for review of the person undertaking exercises;
- f) displaying the visual recordings of the person undertaking exercises together
25 with synchronized annotation information to the person.

DETAILED DESCRIPTION OF THE INVENTION

 Before the invention is described in detail, it is to be understood that this invention is not limited to the particular component parts of the devices described or process
30 steps of the methods described as such devices and methods may vary. It is also to be understood that the terminology used herein is for purposes of describing particular embodiments only, and is not intended to be limiting. It must be noted that, as used in the specification and the appended claims, the singular forms "a," "an" and "the" include singular and/or plural referents unless the context clearly dictates otherwise.

In the context of the present invention, the term anonymously annotated data denotes data where a third person performing the annotation has no knowledge about the identity of the person whose data he is annotating. In particular, the data does not allow for a recognition of the person. One way of achieving the anonymization is by assigning
5 identification numbers to the data. Physical exercise data is data relating to movements or other exercises of a person.

The first two steps of the method describe how two different sets of information about the exercise of the person are gathered. Firstly, physical exercise data is gathered, for example by continuously monitoring sensor signals from the person. At the
10 same time, visual recordings are gathered, for example by using a digital video camera. By synchronously gathering this data it is ensured that later on, a certain portion of the video stream can be attributed to a certain portion of the sensor signal stream and vice versa.

As the visual recordings and the physical exercise data are separate entities, the physical exercise data can then be transmitted to a physically separate annotation unit.
15 The physical separation of the annotation unit provides for an anonymization of the data. At the annotation unit the physical exercise data can be processed into representations of the exercise for review by a third person. The physical exercise data can then be annotated. This includes automatic processing of the data, for example by detecting deviations from motion templates. Furthermore, the third person can include comments and suggestions to provide
20 helpful feedback to the person performing the exercise. Afterwards, the annotation information is transmitted to a display and processing unit at the site of the person performing the exercise. Here, the annotation information is joined with the visual recordings. The recordings of the person undertaking exercises are then displayed to the person together with the synchronized annotation information. The synchronization provides
25 for displaying the annotation at the correct time so the person can directly understand what has caught the attention of the reviewer or the automatic reviewing system.

In summary, with the method according to the present invention an exercise of a person can be reviewed anonymously and feedback can be given to the person. The anonymization allows for the sharing of professional resources, making the reviewing
30 process more efficient. At the same time, when the person receives the feedback it is very clearly shown to him, via the visual recordings, which part of the exercise has prompted the feedback.

In one embodiment of the invention, at the physically separate annotation unit in step d) an avatar is calculated based on the physical exercise data. For the purposes of this

invention, the term 'avatar' shall denote a computer-generated abstract rendering which represents the posture or motions of a person. In simple cases, the avatar may be a stick figure. In more sophisticated cases, the avatar may represent additional information like the pulse rate, the amount of sweating, muscle fatigue and the like. An advantage of using an
5 avatar representation is that the avatar can be rotated on the screen of the annotation unit while representing the exercise. This enables the reviewer to choose the best viewing angle for assessing the exercise.

In a further embodiment of the invention step f) additionally comprises calculating an avatar and displaying the avatar synchronously with the visual recordings and
10 the annotations to the person. In summary, the person will then see the visual recording of his exercise, the annotations and the avatar. This is advantageous as the avatar may depict more clearly the motions of the persons if they are obscured in the visual recording by baggy clothing or if they have not been recorded correctly on camera. Again, the avatar may be rotated to achieve the best viewing perspective. Another option is to provide multiple
15 viewing angles with one or more avatars.

In a further embodiment of the invention transmitting the physical exercise data in step c) and transmitting the annotation information in step e) is undertaken via an interconnected computer network, preferably the internet. This allows a remotely located person to perform the review and the annotation. Suitable protocols can include those of the
20 TCP/IP protocol.

In a further embodiment of the invention the physical exercise data from the person is selected from the group comprising motion data, posture data, electromyographic data, pulse rate, blood pressure, blood oxygen content, blood sugar content, severity of perspiration and/or respiratory rate. These data types either relate to the exercise itself, such
25 as in the case of motion and posture data. Other data types relate to the overall condition or physical fitness of the person. Knowledge about this can give valuable insight into the effectiveness of rehabilitation or training measures. For example, it may be inferred whether the person is in the supercompensation phase after a training stimulus.

In a further embodiment of the invention the annotation information is selected
30 from the group comprising visual information, audio signals and/or speech recordings. Visual information can be in the form of markings such as arrows pointing out a specific issue that are inserted into the images of the avatar. Additionally, small video clips can be inserted to show the correct execution of the exercise. Other visual information can be written comments or graphs showing statistics of data like electromyographic data, pulse rate, blood pressure,

blood oxygen content, blood sugar content, severity of perspiration and/or the respiratory rate. This enables to assess the situation of the person performing the exercise at one glance. Audio signals can be simple beeps when a movement is not performed correctly. Recorded speech comments can be added by the reviewer when this is the simplest way of explaining an exercise.

- 5
- The present invention is further directed towards a system for displaying anonymously annotated physical exercise data to a person undertaking exercises, comprising:
- a physical data processing unit;
 - a display device in communication with the physical data processing unit;
 - 10 - at least one posture recording device assigned to the person undertaking exercises and in communication with the physical data processing unit;
 - a visual recording device in communication with the physical data processing unit;
 - a data storage unit for storing and retrieving data from the physical data
 - 15 processing unit and the visual recording device; the data storage means being in communication with the physical data processing unit;
 - a physically separate annotation unit in connection with the physical data processing unit, the connection being via an interconnected computer network.

In one embodiment of the invention the at least one posture recording device

20 comprises a motion sensor on the person undertaking exercises, the sensor being selected from the group comprising acceleration sensors, inertia sensors and/or gravity sensors. The motion sensors can be worn on the body of the person on selected locations like upper arm, lower arm, upper leg, lower leg or torso. They can be commercially available highly integrated solid state sensors. The transmission of the sensor signals to the posture

25 assessment unit can be undertaken via wire, wirelessly or in a body area network using the electrical conductivity of the human skin. After calculation of the person's posture the result can be present in the form of an avatar.

In a further embodiment of the invention the at least one posture recording device comprises an optical mark on the person undertaking exercises. The posture recording

30 device then employs an optical tracking system for tracking the at least one optical mark. Based on the signals of the optical tracking system a representation of the person's posture is then calculated. The optical marks can be borne on the body of the person on selected locations like upper arm, lower arm, upper leg, lower leg or torso. The tracking of the marks can be effected with a single camera or a multitude of cameras. When a stereo camera is

used, three-dimensional posture and movement data is generated. After image processing and calculation of the person's posture the result can be present in the form of an avatar.

It is also possible to combine several posture monitoring principles. For example, a combination of motion sensors and optical tracking may provide complementary data to better calculate the posture of the person.

A further aspect of the present invention is the use of a system according to the present invention claims for displaying anonymously annotated physical exercise data to a person undertaking exercises.

10 BRIEF DESCRIPTION OF THE DRAWINGS

The present invention will become more readily understood with reference to the following drawing, wherein

Fig. 1 shows a system according to the present invention

Fig. 2 shows a synchronous overlay of visual recordings and an avatar representing physical exercise data

Fig. 3 shows a flowchart of a method according to the present invention

Fig. 4 shows modules for performing a method according to the present invention.

20 DETAILED DESCRIPTION OF THE DRAWINGS

Fig. 1 shows a system according to the present invention for displaying anonymously annotated physical exercise data to a person undertaking exercises. As posture recording devices, the person has motion sensors 3 situated on his thighs and his ankles. Furthermore, optical marks 3' are located on the wrist and the torso. Being physical exercise data, the signals of the motion sensors 3 are transmitted wirelessly to the physical data processing unit 1 where the raw sensor signals are processed into motion and posture data. A video camera 4 records the motions of the person. Furthermore, the physical data processing unit 1 performs optical tracking operations on the video stream of the camera 4 for identifying the position and the movement of the optical marks 3'. This is also processed into motion and posture data and complements the data obtained from the motion sensors 3.

The raw or processed sensor signals and positional information from the optical marks 3' are stored in a data storage unit 5. Furthermore, the video stream of the person performing the exercise is also stored there. The data in the data storage unit 5 is stored together with an information about the time of recording. This makes it possible to

correlate or synchronize the information, for example knowing which position as indicated by posture recording devices 3, 3' corresponds to which frame of a video clip of the person performing the exercise.

Using an interconnected computer network such as the internet 7, the physical data processing unit 1 transmits the processed sensor 3 signals and positional information from the optical marks 3' to a physically separate annotation unit 6. Temporal information is also transmitted. This annotation unit then calculates a visual representation such as an avatar from the received physical data. A physical therapist views the motion of the visual representation on his terminal 8 and comments sequences, thus performing the annotation. The annotation together with the time within the exercise when the annotation has been made is transmitted back to the physical data processing unit 1 at the location of the person undertaking exercises. Again, the transmission is achieved over an interconnected computer network such as the internet 7.

The physical data processing unit 1 then accesses the data storage unit 5 and retrieves the recorded data and video clips from the particular exercise that has been annotated. A movie sequence is generated for viewing by the person and displayed on display 2. In this case, the video stream of the person and an avatar calculated from the recorded data are shown simultaneously. At the appropriate time, the comments of the physical therapist are also displayed or voiced to the person.

Fig. 2 shows a synchronous overlay of visual recordings and an avatar representing physical exercise data. A person has been performing an exercise. Physical data representing his motions has been recorded and used for calculation of an avatar representation. The avatar's motion has been time-resolved and split into a stream of individual frames 20. Likewise, the person's movements have been recorded by a video camera. This video image sequence has also been time-resolved and split into a stream of individual frames 21. As the physical exercise data and the visual recordings have been gathered simultaneously, one common time line can be assigned to them. The time line in Fig. 2 beneath the frame streams arbitrarily begins at 4:16 minutes and ends at 4:21 minutes.

In the exercise of Fig. 2, the person starts with both of his arms stretched lowered. In the images, the left arm is kept stretched and raised along the coronal plane until the hand is above the person's head. The arm is kept in this position while the same movement is supposed to be performed with the right arm. At the time of 4:20, the person is not able to keep his right arm outstretched in the horizontal position. The arm is bent at the elbow. This makes it much easier to lift the arm so at this point no therapeutic benefit is

gained. A physical therapist remotely reviewing the avatar frames 20 can then single out the frame at 4:20 minutes and add a visual or verbal comment. This comment, together with the information that it is to be shown at 4:20 minutes into the exercise, is transmitted to the person for future reviewal. At the person's location the annotation can then be combined with
5 the visual recordings 21 so that the person can relate more directly to the exercise and contemplate his errors in performing it.

Fig. 3 shows a flowchart of a method according to the present invention. The first step 30 is to record the exercise a person is performing visually, using a camera, and via posture data, using sensors. The visual recordings are stored 31 and the posture recordings
10 are transmitted to an annotation system 32. Using the annotation system, a person reviews the posture recordings and adds his comments and markers 33. These annotations are transmitted back to the patient system 34, wherein 'patient' denotes the person performing an exercise. On the patient side, the stored visual recordings are retrieved 35 and combined with the annotations 36 in order to give the person a comprehensive feedback that still does not
15 compromise his anonymity.

Fig. 4 shows modules for performing a method according to the present invention to complement the depiction of a system in Fig. 1. A sensor receiver 40 receives signals from motion sensors or information from the tracking of optical marks. This sensor receiver 40 communicates its data to a movement transmission module 41. Synchronously
20 with the sensor receiver 40, a camera 42 captures a video sequence of the person performing exercises. These video sequences are stored in a storage facility 43. The movement transmission module 41 transmits its data to a remotely located movement receiver 45. This is symbolized by barrier 44 separating the two sub-groups of modules.

The movement receiving module 45 passes the data on to a movement
25 annotator 46 where the data is transformed into processible data and annotated by a reviewer. The annotation together with information on the temporal position of the annotation within the exercise is passed on to annotation transmission module 47. Aforementioned annotation transmission module 47 transmits the information to an annotation receiver 48 located at the sub-group of modules assigned to the person performing the exercise. This annotation
30 information reaches a processing and overlay module 49 which accesses video sequences from the storage module 43 and combines the sequences with the annotation so that the annotation is present at the appropriate time of the video sequence. Finally, via a rendering module 50, the overlaid video sequence is displayed to the person who has performed the exercise.

To provide a comprehensive disclosure without unduly lengthening the specification, the applicant hereby incorporates by reference each of the patents and patent applications referenced above.

The particular combinations of elements and features in the above detailed
5 embodiments are exemplary only; the interchanging and substitution of these teachings with
other teachings in this and the patents/applications incorporated by reference are also
expressly contemplated. As those skilled in the art will recognize, variations, modifications,
and other implementations of what is described herein can occur to those of ordinary skill in
the art without departing from the spirit and the scope of the invention as claimed.
10 Accordingly, the foregoing description is by way of example only and is not intended as
limiting. The invention's scope is defined in the following claims and the equivalents thereto.
Furthermore, reference signs used in the description and claims do not limit the scope of the
invention as claimed.

CLAIMS:

1. A method for displaying anonymously annotated physical exercise data to a person undertaking exercises, comprising the steps of:
 - a) gathering physical exercise data from a person undertaking exercises;
 - b) synchronously gathering visual recordings of the person undertaking
5 exercises;
 - c) transmitting the physical exercise data to a physically separate annotation unit;
 - d) based on the physical exercise data, annotating the physical exercise data at the physically separate annotation unit;
 - e) transmitting the annotation information to a display and processing unit for
10 review of the person undertaking exercises;
 - f) displaying the visual recordings of the person undertaking exercises together with synchronized annotation information to the person.
2. Method according to claim 1, wherein at the physically separate annotation
15 unit in step d) an avatar is calculated based on the physical exercise data.
3. Method according to claims 1 or 2, wherein step f) additionally comprises calculating an avatar and displaying the avatar synchronously with the visual recordings and the annotations to the person.
20
4. Method according to claims 1 to 3, wherein transmitting the physical exercise data in step c) and transmitting the annotation information in step e) is undertaken via an interconnected computer network, preferably the internet.
- 25 5. Method according to claims 1 to 4, wherein the physical exercise data from the person is selected from the group comprising motion data, posture data, electromyographic data, pulse rate, blood pressure, blood oxygen content, blood sugar content, severity of perspiration and/or respiratory rate.

6. Method according to claims 1 to 5, wherein the annotation information is selected from the group comprising visual information, audio signals and/or speech recordings.
- 5 7. A system for displaying anonymously annotated physical exercise data to a person undertaking exercises, comprising:
- a physical data processing unit (1);
 - a display device (2) in communication with the physical data processing unit (1);
- 10 - at least one posture recording device (3, 3') assigned to the person undertaking exercises and in communication with the physical data processing unit (1);
- a visual recording device (4) in communication with the physical data processing unit (1);
 - a data storage unit (5) for storing and retrieving data from the physical data processing unit (1) and the visual recording device (4); the data storage means (5) being in communication with the physical data processing unit (1);
- 15 - a physically separate annotation unit (6) in connection with the physical data processing unit (1), the connection being via an interconnected computer network (7).
- 20 8. System according to claim 7, wherein the at least one posture recording device (3, 3') comprises a motion sensor (3) on the person undertaking exercises, the sensor being selected from the group comprising acceleration sensors, inertia sensors and/or gravity sensors.
- 25 9. System according to claim 7, wherein the at least one posture recording device (3, 3') comprises an optical mark (3') on the person undertaking exercises.
10. Use of a system according to claims 7 to 9 for displaying anonymously annotated physical exercise data to a person undertaking exercises.

1/4

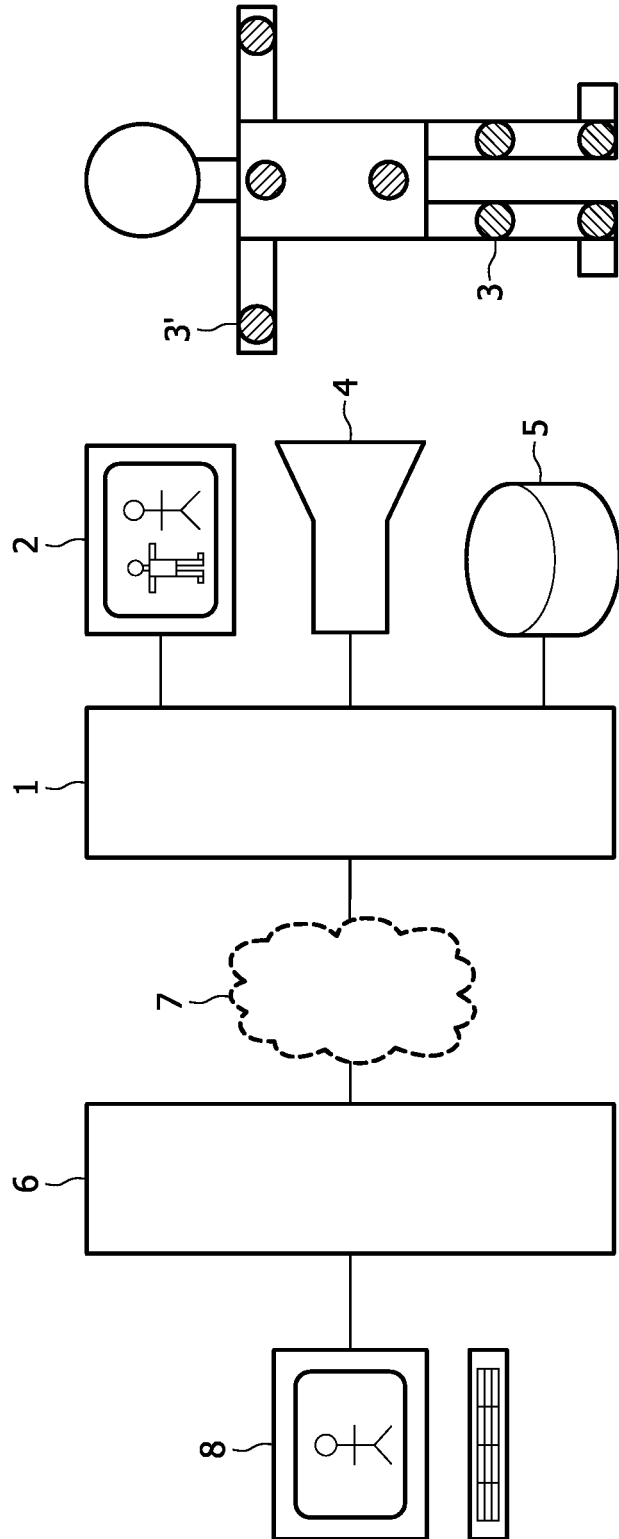

FIG. 1

2/4

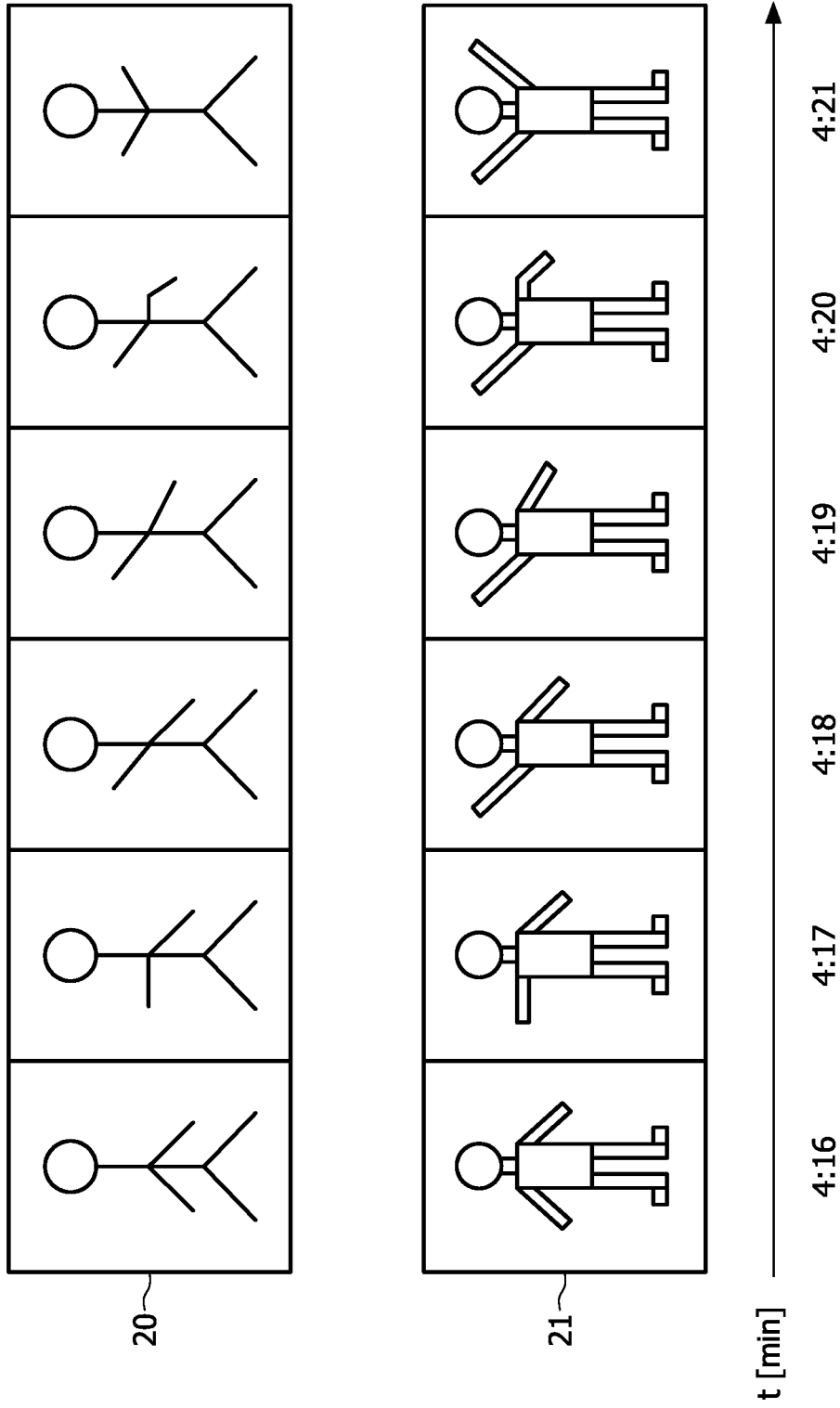

FIG. 2

3/4

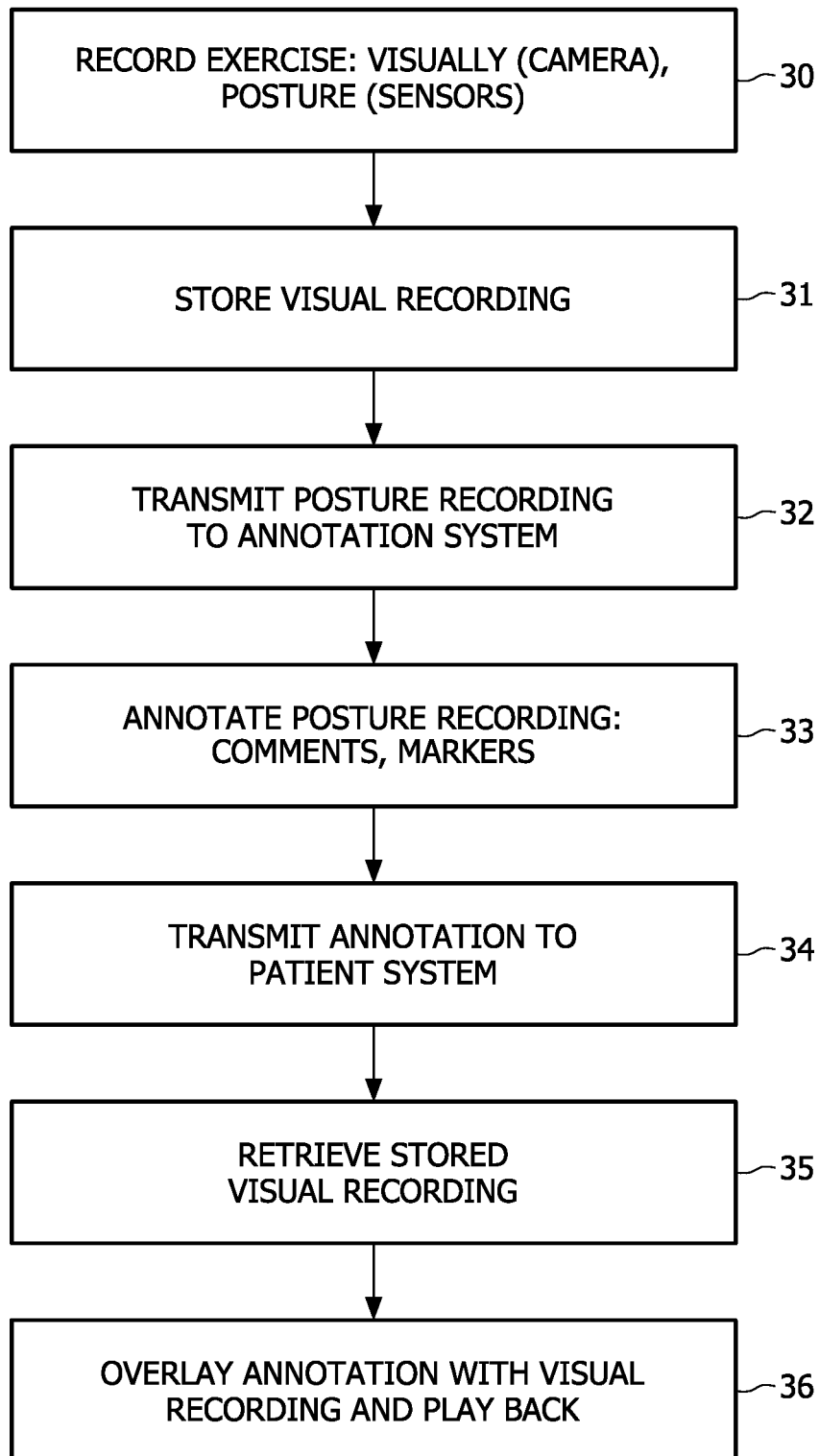

FIG. 3

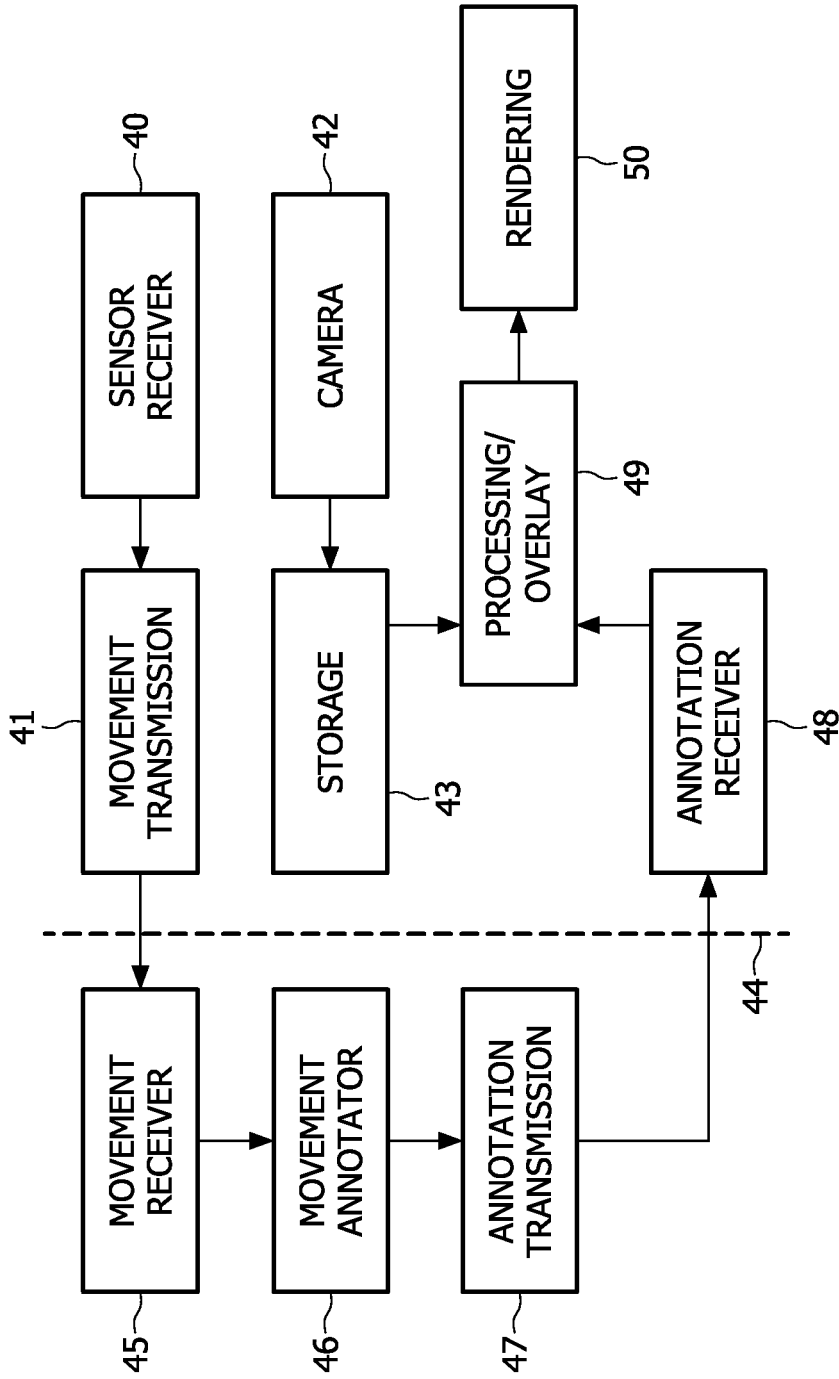

FIG. 4

INTERNATIONAL SEARCH REPORT

International application No PCT/IB2008/053386

A. CLASSIFICATION OF SUBJECT MATTER				
INV. A61B5/11	A61B5/22	A61B5/00		
A63B69/36	G09B19/00	G06F19/00		
ADD. A61B5/024	A61B5/021	A61B5/0488		
		A63B21/00		
		A63B69/00		
According to International Patent Classification (IPC) or to both national classification and IPC				
B. FIELDS SEARCHED				
Minimum documentation searched (classification system followed by classification symbols)				
A61B A63B G09B G06F				
Documentation searched other than minimum documentation to the extent that such documents are included in the fields searched				
Electronic data base consulted during the international search (name of data base and, where practical, search terms used)				
EPO-Internal, WPI Data				
C. DOCUMENTS CONSIDERED TO BE RELEVANT				
Category*	Citation of document, with indication, where appropriate, of the relevant passages	Relevant to claim No.		
X	US 2003/054327 A1 (EVENSEN MARK H [US]) 20 March 2003 (2003-03-20) figures 1,2,4-6,8-10 paragraphs [0001], [0051] - [0055], [0061] - [0063], [0078] - [0081], [0088] - [0091], [0098], [0103] -----	1-10		
X	US 2006/025229 A1 (MAHAJAN SATAYAN [US] ET AL) 2 February 2006 (2006-02-02) paragraphs [0030], [0032], [0033], [0038], [0041] - [0044], [0051], [0057], [0063], [0064], [0075], [0127], [0131], [0133] - [0142] figures 1,4,7,8,17-19 ----- -/--	1-8,10		
<input checked="" type="checkbox"/> Further documents are listed in the continuation of Box C. <input checked="" type="checkbox"/> See patent family annex.				
<table style="width: 100%; border: none;"> <tr> <td style="width: 50%; border: none; vertical-align: top;"> * Special categories of cited documents : *A* document defining the general state of the art which is not considered to be of particular relevance *E* earlier document but published on or after the international filing date *L* document which may throw doubts on priority claim(s) or which is cited to establish the publication date of another citation or other special reason (as specified) *O* document referring to an oral disclosure, use, exhibition or other means *P* document published prior to the international filing date but later than the priority date claimed </td> <td style="width: 50%; border: none; vertical-align: top;"> *T* later document published after the international filing date or priority date and not in conflict with the application but cited to understand the principle or theory underlying the invention *X* document of particular relevance; the claimed invention cannot be considered novel or cannot be considered to involve an inventive step when the document is taken alone *Y* document of particular relevance; the claimed invention cannot be considered to involve an inventive step when the document is combined with one or more other such documents, such combination being obvious to a person skilled in the art. *&* document member of the same patent family </td> </tr> </table>			* Special categories of cited documents : *A* document defining the general state of the art which is not considered to be of particular relevance *E* earlier document but published on or after the international filing date *L* document which may throw doubts on priority claim(s) or which is cited to establish the publication date of another citation or other special reason (as specified) *O* document referring to an oral disclosure, use, exhibition or other means *P* document published prior to the international filing date but later than the priority date claimed	*T* later document published after the international filing date or priority date and not in conflict with the application but cited to understand the principle or theory underlying the invention *X* document of particular relevance; the claimed invention cannot be considered novel or cannot be considered to involve an inventive step when the document is taken alone *Y* document of particular relevance; the claimed invention cannot be considered to involve an inventive step when the document is combined with one or more other such documents, such combination being obvious to a person skilled in the art. *&* document member of the same patent family
* Special categories of cited documents : *A* document defining the general state of the art which is not considered to be of particular relevance *E* earlier document but published on or after the international filing date *L* document which may throw doubts on priority claim(s) or which is cited to establish the publication date of another citation or other special reason (as specified) *O* document referring to an oral disclosure, use, exhibition or other means *P* document published prior to the international filing date but later than the priority date claimed	*T* later document published after the international filing date or priority date and not in conflict with the application but cited to understand the principle or theory underlying the invention *X* document of particular relevance; the claimed invention cannot be considered novel or cannot be considered to involve an inventive step when the document is taken alone *Y* document of particular relevance; the claimed invention cannot be considered to involve an inventive step when the document is combined with one or more other such documents, such combination being obvious to a person skilled in the art. *&* document member of the same patent family			
Date of the actual completion of the international search		Date of mailing of the international search report		
14 January 2009		23/01/2009		
Name and mailing address of the ISA/ European Patent Office, P.B. 5818 Patentlaan 2 NL - 2280 HV Rijswijk Tel. (+31-70) 340-2040, Fax: (+31-70) 340-3016		Authorized officer Olapinski, Michael		

INTERNATIONAL SEARCH REPORT

International application No
PCT/IB2008/053386

C(Continuation). DOCUMENTS CONSIDERED TO BE RELEVANT		
Category*	Citation of document, with indication, where appropriate, of the relevant passages	Relevant to claim No.
Y	<p>US 2004/002634 A1 (NIHTILA JUKKA [FI] NIHTILAE JUKKA [FI]) 1 January 2004 (2004-01-01) cited in the application the whole document</p> <p>-----</p>	1-10
Y	<p>US 2006/166737 A1 (BENTLEY MICHAEL D [US]) 27 July 2006 (2006-07-27) figures 1-3, 8, 9, 11-14 paragraphs [0024] - [0028], [0031], [0037], [0039], [0043], [0044], [0047], [0087], [0088], [0115], [0116]</p> <p>-----</p>	1-10
A	<p>EP 0 816 986 A (HITACHI LTD [JP]) 7 January 1998 (1998-01-07) figure 38 page 30, lines 16-23</p> <p>-----</p>	1-10

INTERNATIONAL SEARCH REPORT

Information on patent family members

International application No

PCT/IB2008/053386

Patent document cited in search report		Publication date		Patent family member(s)		Publication date
US 2003054327	A1	20-03-2003	WO	03024544 A1		27-03-2003
US 2006025229	A1	02-02-2006	NONE			
US 2004002634	A1	01-01-2004	US	2005101845 A1		12-05-2005
US 2006166737	A1	27-07-2006	US	2007270214 A1		22-11-2007
EP 0816986	A	07-01-1998	DE	69736622 T2		13-09-2007

专利名称(译)	用于显示匿名注释的体育锻炼数据的系统和方法		
公开(公告)号	EP2185071A1	公开(公告)日	2010-05-19
申请号	EP2008789619	申请日	2008-08-22
[标]申请(专利权)人(译)	皇家飞利浦电子股份有限公司		
申请(专利权)人(译)	皇家飞利浦电子N.V. 飞利浦知识产权及标准部GMBH		
当前申请(专利权)人(译)	皇家飞利浦电子N.V. 飞利浦知识产权及标准部GMBH		
[标]发明人	LANFERMANN GERD		
发明人	LANFERMANN, GERD		
IPC分类号	A61B5/11 A61B5/22 A61B5/00 A63B21/00 A63B69/00 A63B69/36 G09B19/00 G06F19/00 A61B5/024 A61B5/021 A61B5/0488 A61B5/08		
CPC分类号	A61B5/0002 A61B5/1114 A61B5/1127 A61B5/222 A61B5/744 A61B2562/0219 A63B24/0003 A63B69/00 A63B69/36 A63B71/06 A63B2024/0012 A63B2024/0096 A63B2071/0638 A63B2071/0647 A63B2071/065 A63B2220/05 A63B2220/40 A63B2220/803 A63B2220/806 A63B2220/833 A63B2225/15 A63B2225/20 A63B2225/50 A63B2230/04 A63B2230/202 A63B2230/207 G06F19/3418 G06F19/3481 G09B19/0038 G16H20/30 G16H30/40 G16H40/67 G16H50/50		
代理机构(译)	kroeze antonius , 约翰		
优先权	2007114912 2007-08-24 EP		
外部链接	Espacenet		

摘要(译)

本发明涉及一种向进行锻炼的人显示匿名注释的体育锻炼数据的方法。基于体育锻炼数据，体育锻炼数据在物理上分开的注释单元处注释。在该人的位置处，向该人显示进行锻炼的人的视觉记录以及同步的注释信息。用于执行该方法的系统包括物理数据处理单元(1)，显示设备(2)，至少一个姿势记录设备(3)，视觉记录设备(4)，数据存储单元(5)和物理上独立的注释单元(6)，与物理数据处理单元(1)相连，该连接通过互连的计算机网络(7)。