

(19)



(11)

EP 3 337 387 B1

(12)

EUROPEAN PATENT SPECIFICATION

(45) Date of publication and mention of the grant of the patent:
25.09.2019 Bulletin 2019/39

(51) Int Cl.:
A61B 5/00 (2006.01) A61B 5/042 (2006.01)

(21) Application number: **16758020.8**

(86) International application number:
PCT/US2016/047328

(22) Date of filing: **17.08.2016**

(87) International publication number:
WO 2017/031197 (23.02.2017 Gazette 2017/08)

(54) FLEXIBLE ELECTRODE FOR CARDIAC SENSING AND METHOD FOR MAKING

FLEXIBLE ELEKTRODE ZUR ERFASSUNG VON HERZSIGNALEN UND VERFAHREN ZUR HERSTELLUNG

ÉLECTRODE FLEXIBLE POUR LA DÉTECTION D'UNE ACTIVITÉ CARDIAQUE ET PROCÉDÉ DE FABRICATION

(84) Designated Contracting States:
AL AT BE BG CH CY CZ DE DK EE ES FI FR GB GR HR HU IE IS IT LI LT LU LV MC MK MT NL NO PL PT RO RS SE SI SK SM TR

- **FRANKSON, Danielle**
Dayton, Minnesota 55327 (US)
- **MERRIAM, Patrick A.**
St. Paul, Minnesota 55117 (US)
- **MAIERHOFER, Edward J.**
Brooklyn Park, Minnesota 55443 (US)
- **JONES, Matthew P.**
Shoreview, Minnesota 55126 (US)

(30) Priority: **20.08.2015 US 201562207814 P**

(43) Date of publication of application:
27.06.2018 Bulletin 2018/26

(73) Proprietor: **Boston Scientific Scimed Inc.**
Maple Grove, Minnesota 55311 (US)

(74) Representative: **Pfenning, Meinig & Partner mbB**
Patent- und Rechtsanwälte
Joachimsthaler Straße 10-12
10719 Berlin (DE)

- (72) Inventors:
- **SALLEE, Gregory**
Arden Hills, Minnesota 55112 (US)
 - **GUNTER, Kenneth L.**
Maple Grove, Minnesota 55311 (US)

(56) References cited:
US-A1- 2004 220 652 US-A1- 2009 293 270
US-A1- 2010 230 285 US-A1- 2013 253 298
US-A1- 2014 262 462

EP 3 337 387 B1

Note: Within nine months of the publication of the mention of the grant of the European patent in the European Patent Bulletin, any person may give notice to the European Patent Office of opposition to that patent, in accordance with the Implementing Regulations. Notice of opposition shall not be deemed to have been filed until the opposition fee has been paid. (Art. 99(1) European Patent Convention).

Description

TECHNICAL FIELD

[0001] The present invention relates to cardiac signal sensing devices. More specifically, the invention relates to flexible electrodes and methods for making flexible electrodes for use in a cardiac mapping catheter.

BACKGROUND

[0002] Cardiac arrhythmias may lead to heart disease and death. Arrhythmias may be treated by medication, implantable devices, or by the ablation of specific heart tissue found to be causing arrhythmia. Ablation may be performed by a number of techniques, including the local application of energy, for example, radio frequency energy, or by the application of cryogenic temperatures to the site of the problem tissue.

[0003] The specific heart tissue responsible for arrhythmia in a patient may be identified by moving a mapping catheter having one or more electrodes around the interior of the heart and measuring cardiac signals to sense changes in the electrical fields. A map of the electrical conductivity of the heart may be formed from the measurements to identify abnormalities which may be candidates for ablation. Some mapping catheters are designed such that the electrodes may physically contact the heart wall, including flexible designs that are inserted in a compact form and later deployed into a basket-like array. Such an array is deployed after entrance into the heart, and undeployed upon completion of the mapping and prior to removal from the heart.

[0004] A mapping catheter having multiple electrodes which must be deployed and undeployed within the heart may benefit from an improved electrode structure. Document US 2014/262462 A1 relates to thicker electrodes that are provided on a microelectronic device using thermo-compression bonding. A thin-film electrical conducting layer forms electrical conduits and bulk depositing provides an electrode layer on the thin-film electrical conducting layer. An insulating polymer layer encapsulates the thin-film electrical conducting layer and the electrode layer. Some of the insulating layer is removed to expose the electrode layer. Further related prior art is described, e.g., in documents US 2009/293270 A1, US 2010/230285 A1, US 2013/253298 A1, and US 2004/220652 A1.

SUMMARY

[0005]

Example 1 is an electrode for cardiac signal sensing, the electrode including a conductive layer, an intermediate layer, an iridium-containing layer, an iridium oxide layer, and an insulating polymer layer. The conductive layer is formed on a portion of a flexible

polymer substrate. The intermediate metal layer has a first portion and a second portion, and is formed on the conductive layer. The iridium-containing layer has a first portion and a second portion, and formed on the first portion of the intermediate metal layer. The iridium-containing layer includes at least 50 wt. % iridium. The iridium oxide layer is formed on the first portion of the iridium-containing layer. The insulating polymer layer is formed on the second portion of the intermediate metal layer and the second portion of the iridium-containing layer. The iridium-containing layer is not formed on the second portion of the intermediate metal layer; and the iridium oxide layer is not formed on the second portion of the iridium-containing layer.

In Example 2, the electrode of Example 1, wherein the iridium-containing layer consists of between 50 wt. % and 99 wt. % iridium, and the balance is platinum.

In Example 3, the electrode of Example 1, wherein the iridium-containing layer includes at least 99 wt. % iridium.

In Example 4, the electrode of any of Examples 1-3, wherein the insulating polymer layer is a parylene polymer.

In Example 5, the electrode of Example 4, wherein the parylene polymer is selected from the group consisting of poly(p-xylylene), poly(monochloro-p-xylylene), and poly(dichloro-p-xylylene).

In Example 6, the electrode of Example 5, wherein the parylene polymer is poly(monochloro-p-xylylene).

In Example 7, the electrode of any of Examples 1-6, wherein the intermediate metal layer includes gold.

Example 8 is a cardiac mapping catheter including an elongate catheter body and a plurality of splines projecting from an end of the catheter body. The splines are flexibly deployable between a radially retracted position and radially extended position. Each of the splines includes a flexible polymer substrate and a plurality of electrodes formed on the flexible polymer substrate, wherein each of the electrodes is according to any of claims 1-7.

Example 9 is a method for making an electrode for cardiac signal sensing, the electrode formed on a flexible polymer substrate having a conductive layer and an intermediate metal layer disposed on the conductive layer. The method includes depositing an iridium-containing layer onto a portion of the intermediate metal layer, depositing an insulating polymer layer, removing the insulating polymer layer from a portion of the iridium-containing layer to form an exposed surface, and electrochemically oxidizing at least a portion of the iridium-containing layer at the exposed surface to form an iridium oxide layer on the iridium-containing layer. The iridium-containing layer includes at least 50 wt. % iridium. The insulating polymer layer is deposited on the flexible

polymer substrate, the conductive layer, the intermediate layer, and the iridium-containing layer.

In Example 10, the method of Example 9, wherein removing the insulating polymer layer includes laser ablating the insulating polymer layer from the portion of the iridium-containing layer.

In Example 11, the method of any of Examples 9-10, wherein depositing the insulating polymer layer includes depositing a parylene polymer by vapor deposition.

In Example 12, the method of any of Examples 9-11, wherein depositing the iridium-containing layer includes applying a first mechanical mask to the substrate, depositing the iridium-containing layer by sputter deposition, and removing the first mechanical mask. The first mechanical mask includes a first opening aligned with the intermediate metal layer to define the portion of the intermediate metal layer.

In Example 13, the method of any of Examples 9-12, wherein removing the insulating polymer layer includes applying a second mechanical mask to the substrate, laser ablating the insulating polymer layer from the portion of the iridium-containing layer; and removing the second mechanical mask. The second mechanical mask includes a second opening aligned with the portion of the iridium-containing layer, wherein the second opening is smaller than the first opening.

In Example 14, the method of any of Examples 9-12, wherein removing the insulating polymer layer includes applying a second mechanical mask to the substrate, laser ablating the insulating polymer layer from the portion of the iridium-containing layer; and removing the second mechanical mask. The second mechanical mask includes a second opening aligned with the portion of the iridium-containing layer, wherein the second opening is about the same size as the first opening.

In Example 15, the method of any of Examples 9-14, wherein electrochemically oxidizing includes immersing the substrate in an electrolytic solution, cycling the iridium-containing layer between positive and negative voltages until a desired thickness of iridium oxide is formed on the surface of the portion of iridium-containing layer, and removing the substrate from the electrolytic solution.

Example 16 is an electrode for cardiac signal sensing, the electrode including a conductive layer, an intermediate layer, an iridium-containing layer, an iridium oxide layer, and an insulating polymer layer. The conductive layer is formed on a portion of a flexible polymer substrate. The intermediate metal layer has a first portion and a second portion, and is formed on the conductive layer. The iridium-containing layer has a first portion and a second portion, and formed on the first portion of the intermediate metal layer. The iridium-containing layer includes at least 50 wt. % iridium. The iridium oxide layer is formed on the

first portion of the iridium-containing layer. The insulating polymer layer is formed on the second portion of the intermediate metal layer and the second portion of the iridium-containing layer. The iridium-containing layer is not formed on the second portion of the intermediate metal layer, and the iridium oxide layer is not formed on the second portion of the iridium-containing layer.

In Example 17, the electrode of Example 16, wherein the iridium-containing layer consists of between 50 wt. % and 99 wt. % iridium, and the balance is platinum.

In Example 18, the electrode of Example 16, wherein the iridium-containing layer includes at least 99 wt. % iridium.

In Example 19, the electrode of any of Examples 16-18, wherein the intermediate metal layer includes gold.

In Example 20, the electrode of any of Examples 16-19, wherein the conductive layer includes copper.

In Example 21, the electrode of any of Examples 16-20, wherein the insulating polymer layer is a parylene polymer.

In Example 22, the electrode of Example 21, wherein the parylene polymer is selected from the group consisting of poly(p-xylylene), poly(monochloro-p-xylylene), and poly(dichloro-p-xylylene).

In Example 23, the electrode of Example 22, wherein the parylene polymer is poly(monochloro-p-xylylene).

Example 24 is a method for making an electrode for cardiac signal sensing, the electrode formed on a flexible polymer substrate having a conductive layer and an intermediate metal layer disposed on the conductive layer. The method includes depositing an iridium-containing layer onto a portion of the intermediate metal layer, depositing an insulating polymer layer, removing the insulating polymer layer from a portion of the iridium-containing layer to form an exposed surface, and electrochemically oxidizing at least a portion of the iridium-containing layer at the exposed surface to form an iridium oxide layer on the iridium-containing layer. The iridium-containing layer includes at least 50 wt. % iridium. The insulating polymer layer is deposited on the flexible polymer substrate, the conductive layer, the intermediate layer, and the iridium-containing layer.

In Example 25, the method of Example 24, wherein removing the insulating polymer layer includes laser ablating the insulating polymer layer from the portion of the iridium-containing layer.

In Example 26, the method of any of Examples 24-25, wherein depositing the insulating polymer layer includes depositing a parylene polymer by vapor deposition.

In Example 27, the method of Example 26, wherein the parylene polymer is poly(monochloro-p-xylylene).

In Example 28, the method of any of Examples 24-27, wherein the intermediate metal layer includes gold.

In Example 29, the method of any of Examples 24-28, wherein depositing the iridium-containing layer includes applying a first mechanical mask to the substrate, depositing the iridium-containing layer by sputter deposition, and removing the first mechanical mask. The first mechanical mask includes a first opening aligned with the intermediate metal layer to define the portion of the intermediate metal layer.

In Example 30, the method of any of Examples 24-29, wherein removing the insulating polymer layer includes applying a second mechanical mask to the substrate, laser ablating the insulating polymer layer from the portion of the iridium-containing layer; and removing the second mechanical mask. The second mechanical mask includes a second opening aligned with the portion of the iridium-containing layer, wherein the second opening is smaller than the first opening.

In Example 31, the method of any of Examples 24-29, wherein removing the insulating polymer layer includes applying a second mechanical mask to the substrate, laser ablating the insulating polymer layer from the portion of the iridium-containing layer; and removing the second mechanical mask. The second mechanical mask includes a second opening aligned with the portion of the iridium-containing layer, wherein the second opening is about the same size as the first opening.

In Example 32, the method of any of Examples 24-31, wherein electrochemically oxidizing includes immersing the substrate in an electrolytic solution, cycling the iridium-containing layer between positive and negative voltages until a desired thickness of iridium oxide is formed on the surface of the portion of iridium-containing layer, and removing the substrate from the electrolytic solution.

Example 33 is a cardiac mapping catheter including an elongate catheter body and a plurality of splines projecting from an end of the catheter body. The splines are flexibly deployable between a radially retracted position and radially extended position. Each of the splines includes a flexible polymer substrate and a plurality of electrodes formed on the flexible polymer substrate. Each of the electrodes includes a conductive layer, an intermediate layer, an iridium-containing layer, an iridium oxide layer, and an insulating polymer layer. The conductive layer is formed on a portion of a flexible polymer substrate. The intermediate metal layer has a first portion and a second portion, and is formed on the conductive layer. The iridium-containing layer has a first portion and a second portion, and formed on the first portion of the intermediate metal layer. The iridium-containing layer includes at least 50 wt. % iridium. The iridium oxide layer is formed on the first portion of the iridium-

containing layer. The insulating polymer layer is formed on the second portion of the intermediate metal layer and the second portion of the iridium-containing layer. The iridium-containing layer is not formed on the second portion of the intermediate metal layer. The iridium oxide layer is not formed on the second portion of the iridium-containing layer.

In Example 34, the catheter of Example 33, wherein the iridium-containing layer includes at least 99 wt. % iridium.

In Example 35, the catheter of any of Examples 33-34, wherein the insulating polymer layer includes poly(monochloro-p-xylylene).

[0006] While multiple embodiments are disclosed, still other embodiments of the present invention will become apparent to those skilled in the art from the following detailed description and drawings, which show and describe illustrative embodiments of the invention. Accordingly, the drawings and detailed description are to be regarded as illustrative in nature and not restrictive.

BRIEF DESCRIPTION OF THE DRAWINGS

[0007]

FIG. 1 is a schematic view of a cardiac mapping catheter suitable for use with embodiments of the present invention.

FIGS. 2A and 2B are partial perspective views showing a distal end of the mapping catheter of FIG. 1.

FIG. 3 is a schematic cross-sectional view of an electrode in accordance with embodiments of the present invention.

FIGS. 4-12 are schematic views showing a method for making the electrode of FIG. 3 in accordance with embodiments of the present invention.

[0008] While the invention is amenable to various modifications and alternative forms, specific embodiments have been shown by way of example in the drawings and are described in detail below. The intention, however, is not to limit the invention to the particular embodiments described. On the contrary, the invention is intended to cover all modifications, equivalents, and alternatives falling within the scope of the invention as defined by the appended claims.

DETAILED DESCRIPTION

[0009] A more complete understanding of the present invention is available by reference to the following detailed description of numerous aspects and embodiments of the invention. The detailed description of the invention which follows is intended to illustrate but not limit the invention.

[0010] Electrodes embodying the present invention may be employed in cardiac mapping catheters as de-

scribed in "CARDIAC MAPPING CATHETER" (U.S. Pat. No. 8,447,377, issued May 21, 2013). Such catheters typically have several flexible splines, each spline including a plurality of electrodes. Electrode embodiments of the present invention are able to flex while also maintaining low impedance and biocompatibility.

[0011] FIG. 1 provides an illustrative but non-limiting example of a cardiac mapping catheter 10 including electrodes embodying the present invention. As shown in FIG. 1, the cardiac mapping catheter 10 may include a handle 12, an elongate lead body 14, an electrode assembly 16, and an electrical connection 18. The lead body 14 may extend from a proximal end 20 to a distal end 22. The electrode array 16 may project from the distal end 22 of the lead body 14. The lead body 14 may be connected at the proximal end 20 to the handle 12. The electrical connection 18 may extend from the handle 12 to a mapping data recording and analysis system (not shown). The handle 12 may include an articulation control 24 and a deployment control 26.

[0012] The articulation control 24 may control bending of the distal end 22 of the lead body 14 by way of one or more articulation control elements, for example wires (not shown) extending from the articulation control 24 to the distal end 22 by way of one or more lumens (not shown) extending through the lead body 14 from the proximal end 20 to the distal end 22. Bending the distal end 22 provides for flexibility in maneuvering the electrode array 16 within a patient's heart.

[0013] The deployment control 26 may control deployment of the electrode array 16 by way of a deployment control element 28 (shown in FIG. 2B) extending from the deployment control 26 to the electrode array 16 by way of one of the lumens extending through the lead body 14. The lumens may also include a set of electrical conductors (not shown) extending from the electrode array 16 to handle 12 to connect the electrode array 16 to the mapping data recording and analysis system.

[0014] FIGS. 2A and 2B are partial perspective views showing the electrode array 16 and the distal end 22 of the cardiac mapping catheter 10 of FIG. 1. FIG. 2A shows the electrode array 16 undeployed in a radially retracted position. FIG. 2B shows the electrode array 16 deployed in a radially extended position. As shown in FIGS. 2A and 2B, the electrode array 16 may include a plurality of splines 30 and an end cap 32. Each of the plurality of splines 30 may extend between the distal end 22 and the end cap 32. Each of the splines 30 may include a flexible polymer substrate 34 and a plurality of electrodes 36. In the exemplary embodiment shown in FIGS. 2A and 2B, there are eight splines 30, each including eight electrodes 36, for a total of sixty-four electrodes in the electrode array 16. However, it is understood that embodiments may include greater or fewer than eight splines 30, and greater or fewer than eight electrodes 36 on each of the splines 30. As shown in FIG. 2B, the deployment control element 28 may extend from the end cap 32 and into the lead body 14 at the distal end 22. The deployment control

element 28 may be a wire connecting the end cap 32 to the deployment control 26 (FIG. 1) such that movement of the deployment control 26 may cause the wire to move in the proximal direction and pull the end cap 32 in the proximal direction. Movement of the end cap 32 in the proximal direction may cause the plurality of splines 30 to flex radially outward and deploy the electrode array 16 as shown in FIG. 2B.

[0015] In use, the cardiac mapping catheter 10 may be inserted into a patient's vasculature with the electrode array 16 in the undeployed, radially retracted position shown in FIG. 2A and advanced to the interior of the patient's heart. Once within the heart, the electrode array 16 may be deployed by deployment control 26 as described above into the radially extended position shown in FIG. 2B to sense the cardiac signals within the heart. The sensed cardiac signals may be transmitted to the mapping data recording and analysis system by way of the set of electrical conductors extending through the lead body 14 from the electrode array 16 to handle 12, and electrical connection 18. Once the cardiac mapping is completed, the electrode array 16 may be undeployed into the radially retracted position and withdrawn from the patient.

[0016] As shown in FIGS. 2A and 2B, each of the electrodes 36 may be formed on the flexible polymer substrate 34. In some embodiments, the electrodes 36 are able to flex with deployment of the electrode array 16, while also maintaining low impedance and biocompatibility. In some embodiments, once the electrode array 16 is deployed, at least some of the electrodes 36 may be curved. The electrodes 36 are shown in FIGS. 2A and 2B as circular in shape. However, embodiments having other shapes, such as rectangular, oval, racetrack, or a combination of shapes are envisioned.

[0017] FIG. 3 illustrates details of the electrode 36 in accordance with embodiments of the present invention. For clarity, a single electrode 36 is illustrated in FIGS. 3-12. FIG. 3 is a schematic cross-sectional view of one of the splines 30 through one of the electrodes 36. As shown in FIG. 3, the electrode 36 may include a conductive layer 40, an intermediate metal layer 42, an iridium-containing layer 44, an iridium oxide layer 46, and an insulating polymer layer 48. The conductive layer 40 may be formed on a portion of the flexible polymer substrate 34. The intermediate metal layer 42 may be formed on at least a portion of the conductive layer 40. The iridium-containing layer 44 may be formed on a first portion 62 of the intermediate metal layer 42, and may not be formed on a second portion 64 of the intermediate metal layer 42. The iridium oxide layer may be formed on a first portion 66 of the iridium-containing layer 44, and may not be formed on a second portion 68 of the iridium-containing layer 44. The insulating polymer layer 48 may be formed on the second portion 64 of the intermediate metal layer 42, and the second portion 68 of the iridium-containing layer 44. The insulating polymer layer 48 may not be formed on the iridium-oxide layer 46.

[0018] In some embodiments, the conductive layer 40 may be made of a non-biocompatible material, such as copper or a copper alloy. The conductive layer 40 may have a suitable thickness. For example, the conductive layer 40 may have a thickness of as little as about 2 microns, about 4 microns, about 6 microns, or about 7 microns, or as great as about 9 microns, about 10 microns, about 12 microns, or about 14 microns, or have thickness within any range defined between any pair of the foregoing values. In exemplary embodiments, the conductive layer 40 may have a thickness from about 2 microns to about 14 microns, from about 4 microns to about 12 microns, from about 6 microns to about 10 microns, or from about 7 microns to about 9 microns. In some examples, the conductive layer 40 may have a thickness of about 8 microns.

[0019] In some embodiments, the intermediate metal layer 42 may be made of gold or a gold alloy and may have a suitable thickness. For example, in some embodiments, the intermediate metal layer 42 may have a thickness of as little as about 0.1 microns, about 0.5 microns, or about 1 micron, or as great as about 2 microns, about 3 microns, or about 4 microns, or have thickness within any range defined between any pair of the foregoing values. In exemplary embodiments, the intermediate metal layer 42 may have a thickness from about 0.1 microns to about 4 microns, from about 0.5 microns to about 3 microns, or from about 1 micron to about 2 microns. In some examples, the intermediate metal layer 42 may have a thickness of about 1.5 microns. The intermediate metal layer 42 may provide oxidation protection of the underlying conductive layer 40, and provide an additional barrier between the conductive layer and body tissues.

[0020] In some embodiments, the iridium-containing layer 44 may be formed primarily of iridium. For example, iridium may be present in the iridium-containing layer 44 in an amount as little as about 50 wt. %, about 60 wt. %, or about 70 wt. %, or as great as about 80 wt. %, about 90 wt. %, or about 100 wt. %, or may be present within any range defined between any pair of the foregoing values. In exemplary embodiments, iridium may be present in the iridium-containing layer 44 in an amount from about 50 wt. % to about 100 wt. %, from about 60 wt. % to about 90 wt. %, or from about 70 wt. % to about 80 wt. %. In some examples, iridium-containing layer 44 may include at least 99 wt. % iridium. In some embodiments, the iridium-containing layer 44 may be formed primarily of iridium and platinum may make up the balance. For example iridium may be present in the iridium-containing layer 44 in an amount as little as about 50 wt. %, about 60 wt. %, or about 70 wt. %, or as great as about 80 wt. %, about 90 wt. %, or about 99 wt. %, or may be present within any range defined between any pair of the foregoing values, and the balance platinum. In exemplary embodiments, iridium may be present in the iridium-containing layer 44 in an amount from about 50 wt. % to about 100 wt. %, from about 60 wt. % to about 90 wt. %, or from about 70 wt. % to about 80 wt. %, and the balance plat-

inum.

[0021] In some embodiments, the insulating polymer layer 48 may be a biocompatible polymer, such as a biocompatible parylene polymer. In some embodiments, the parylene polymer may be one of poly(p-xylylene) also known as parylene N, poly(monochloro-p-xylylene) also known as parylene C, or poly(dichloro-p-xylylene) also known as parylene D. In exemplary embodiments, the parylene polymer may be poly(monochloro-p-xylylene).

[0022] As shown in FIG. 3, the spline 30 may further include an electrical trace 50, an electrical interconnect 52, and a backside insulating layer 54. The electrical trace 50 may be formed on a side of the flexible polymer substrate 34 opposite the conductive layer 40. The electrical trace 50 runs along a length of the spline 30 to one of the set of electrical conductors extending through the lead body 14 (FIG. 1). The electrical interconnect 52 extends through the flexible polymer substrate 34 from the electrical trace 50 to the conductive layer 40 to electrically connect the electrode 36 to the electrical trace 50. The backside insulating layer 54 covers the electrical trace 50 and at least a portion of the flexible polymer substrate 34 on the side of the flexible polymer substrate 34 opposite the conductive layer 40 to electrically isolate the electrical trace 50.

[0023] The flexible polymer substrate 34 may be made of a polyimide polymer. The electrical trace 50 and the electrical interconnect 52 may be made of copper or a copper alloy. The backside insulating layer 54 may also be made of a polyimide polymer and may itself be biocompatible, or may be covered with an additional biocompatible layer (not shown).

[0024] FIGS. 4-12 are schematic views illustrating a method for fabricating the electrode 36 shown in FIG. 3 in accordance with embodiments of the present invention. The method may begin as shown in FIG. 4 with the flexible polymer substrate 34, the conductive layer 40, the intermediate metal layer 42, the electrical trace 50, and the electrical interconnect 52 already made in the form of a flexible printed circuit (FPC). The conductive layer 40 and the intermediate metal layer 42 may already be patterned to form a basis of the electrode 36 as shown. The backside insulating layer 54 may be included in the FPC as shown, or may be attached by an adhesive in a separate step at any point in the fabrication process.

[0025] As shown in FIG. 5, a first mechanical mask 76 may be applied to the flexible polymer substrate 34. The first mechanical mask 76 includes a first opening 78 (one shown) for each of the electrodes 36. In some embodiments, the first opening 78 is smaller than the pattern of the intermediate metal layer 42 such that when the first mechanical mask 76 is applied to the intermediate metal layer 42, the edges of the intermediate metal layer 42 are not exposed. That is, the first mechanical mask 76 may be aligned to cover the edges of the intermediate metal layer 42 while at least a portion of the intermediate metal layer 42 may be exposed through the first opening 78.

[0026] As shown in FIG. 6, after the first mechanical mask 76 is applied, the iridium-containing layer 44 may be deposited on the portion of the surface of the intermediate metal layer 42 exposed by the first opening 78. Deposition of the iridium-containing layer 44 may be by any of a number of methods known in the art, for example, sputter deposition or evaporative deposition. Edges of the first mechanical mask 76 may not be perfectly square or in perfect contact with the intermediate metal layer 42 and some deposited material will deposit, or "bleed", under the edges of the first mechanical mask 76. As a result, a deposited area of the iridium-containing layer 44 may be larger than the first opening 78, but smaller than the area of the intermediate metal layer 42. In some embodiments, a layer 80 of the deposited iridium-containing metal may also be formed on the first mechanical mask 76 during deposition. After deposition of the iridium-containing layer 44, the first mechanical mask 76 may be removed as shown in FIG. 7. In this way, the first portion 62 of the intermediate metal layer 42, which is covered by the iridium-containing layer 44, and the second portion 64 of the intermediate metal layer 42, which is not covered by the iridium-containing layer 44, may be formed as shown in FIG. 7.

[0027] In some embodiments, the iridium-containing layer 44 as deposited may have a suitable thickness. For example, in some embodiments, the iridium-containing layer 44 may have a thickness of as little as about 0.1 microns, about 0.2 microns, or about 0.4 microns, or as great as about 0.6 microns, about 0.8 microns, or about 1 micron, or have thickness within any range defined between any pair of the foregoing values. In exemplary embodiments, the iridium-containing layer 44 may have a thickness from about 0.1 microns to about 1 micron, from about 0.2 microns to about 0.8 microns, or from about 0.4 microns to about 0.6 microns. In some examples, the iridium-containing layer 44 may have a thickness of about 0.5 microns as deposited.

[0028] As shown in FIG. 8, after the formation of the iridium-containing layer 44, the insulating polymer layer 48 may be deposited on the flexible substrate 34, the conductive layer 40, the intermediate metal layer 42, and the iridium-containing layer 44. Deposition of the insulating polymer layer 48 may be, for example, dip coating, spray coating, or vapor deposition. In some embodiments, the insulating polymer layer 48 includes a parylene polymer and the parylene polymer may be deposited by vapor deposition. The vapor deposition of the parylene polymer may include sublimation of a parylene dimer, pyrolyzation of the parylene dimer to form a parylene monomer, and condensation of the parylene monomer onto the flexible substrate 34, the conductive layer 40, the intermediate metal layer 42, and the iridium-containing layer 44 to form the insulating polymer layer 48. In some embodiments, the parylene polymer may be poly(monochloro-p-xylylene) produced from a dichloro-[2,2]-paracyclophane dimer. In other embodiments, the parylene polymer may be poly(p-xylylene) produced

from a [2,2]-paracyclophane dimer. In some embodiments, the parylene polymer may poly(dichloro-p-xylylene) produced from a tetrachloro-[2,2]-paracyclophane dimer.

[0029] Following deposition of the insulating polymer layer 48, the insulating polymer layer 48 over a portion of the iridium-containing layer 44 may be removed. In some embodiments, removing the insulating polymer layer 48 from the portion of the iridium-containing layer 44 may be as shown in FIGS. 9-11. As shown in FIG. 9, a second mechanical mask 82 may be applied to the flexible polymer substrate 34. The second mechanical mask 82 includes a second opening 84 (one shown) for each of the electrodes 36. In some embodiments, the second opening 84 is smaller than the first opening 78 of the first mechanical mask 76. In other embodiments, the second opening 84 is about the same size as the first opening 78. In still other embodiments, the second mechanical mask 82 and the first mechanical mask 76 may be the same mask. In any of the aforementioned embodiments, when the second mechanical mask 82 is applied to the iridium-containing layer 44, the edges of the iridium-containing layer 44 are not exposed through the second opening 84. That is, the second mechanical mask 82 may be aligned to cover the edges of the iridium-containing layer 44 while at least a portion of the iridium-containing layer 44 may be exposed through the second opening 84.

[0030] As shown in FIG. 10, after the second mechanical mask 82 is applied, the insulating polymer layer 48 exposed by the second opening 84 may be removed by laser ablation, as is known in the art. The second mechanical mask 82 protects the insulating polymer layer 48 formed on the edge of the iridium-containing layer 44, as well as on the flexible polymer substrate 34, the second portion 60 of the conductive layer 40, and the second portion 64 of the intermediate metal layer 42. After laser ablation of the insulating polymer layer 48, the second mechanical mask 82 may be removed as shown in FIG. 11. In this way, the first portion 66, which is not covered by the insulating polymer layer 48, and the second portion 68, which is covered by the insulating polymer layer 48, of the iridium-containing layer 44 may be formed as shown in FIG. 11. Alternatively, in some embodiments, a spot size of the laser used for laser ablation may be small enough compared to the size of the first portion 66, and the accuracy with which the laser spot may be positioned may be great enough, that the insulating polymer layer 48 may be removed without the need for the protection of the second mechanical mask 82.

[0031] As shown in FIG. 12, after formation of the insulating polymer layer 48, the iridium-containing layer 44 may be activated by forming the iridium oxide layer 46 on the first portion 66 of the iridium-containing layer 44. The activation may reduce the electrical impedance of the electrode 36 by as much as three orders of magnitude compared to the electrode 36 without the iridium oxide layer 46.

[0032] In some embodiments, the iridium oxide layer 46 may be formed by electrochemically oxidizing the first portion 66 of the iridium-containing layer 44. In some embodiments, the flexible polymer substrate 34 may be immersed in an electrolytic solution such that the first portion 66 of the iridium-containing layer 44 may be exposed to an electrolytic solution. Examples of the electrolytic solution may include a saline solution such as phosphate buffered saline solution. A cathode may also be positioned within the electrolytic solution and a voltage may be applied between the cathode and the electrode 36 to pass an electrical current between the cathode and the electrode 36. Oxygen may be released from the electrolytic solution when the voltage is applied. The released oxygen reacts with the iridium of the iridium-containing layer 44 to form the iridium oxide layer 46. In some embodiments, the voltage may be cycled between positive and negative voltages until a desired thickness of iridium oxide is formed. Once the desired thickness of iridium oxide is formed, the flexible polymer substrate 34 may be removed from the electrolytic solution. Forming the iridium oxide layer 46 in this way may produce improved adhesion of the iridium oxide layer 46 compared to, for example, sputter depositing a layer of iridium oxide directly. In addition, the iridium oxide layer 46 may provide improved electrical performance by reducing impedance of the electrode 36 by at least 25% compared to sputter depositing a layer of iridium oxide directly.

[0033] As shown in FIG. 12, the thickness of the iridium-containing layer 44 at the first portion 66 may decrease from its as-deposited thickness as iridium from the iridium-containing layer 44 reacts to form the iridium oxide layer 46. In some embodiments, following activation, the iridium-containing layer 44 at the first portion 66 may have a thickness as little as about 10%, about 20%, about 30%, or about 40%, or as much as about 60%, about 70%, about 80%, or about 90% of the as-deposited thickness, or have thickness within any range defined between any pair of the foregoing values. In exemplary embodiments, following activation, the iridium-containing layer 44 may have a thickness from about 10% to about 90%, from about 20% to about 80%, from about 30% to about 70%, or from about 40% to about 60% of the as-deposited thickness. In some examples, iridium-containing layer 44 may have a thickness following activation that is about 50% of the as-deposited thickness.

[0034] The iridium-containing layer 44 may have a high melting point, such as in excess of 2000°C. The iridium-containing layer 44 may also have a partially reflective surface finish that reflects at least a portion of the laser energy from the surface during a laser ablation process. Thus, the iridium-containing layer 44 may be able resist laser damage while the insulating polymer layer 48 exposed by the second opening 84 is removed. This resistance to damage may allow for a more thorough removal of the insulating polymer layer 48 by a lengthier laser ablation process to produce a cleaner surface on the first portion 66 of the iridium-containing layer 44. The cleaner

surface on the first portion 66 may allow the iridium oxide layer 46 to form more evenly over the first portion 66 of the iridium-containing layer 44 leading to improved impedance. The cleaner surface may also lead to improved adhesion of the iridium oxide layer 46 to the iridium-containing layer 44, which may enable electrodes 36 to be able to flex with deployment of the electrode array 16, while also maintaining low impedance and biocompatibility.

[0035] In the embodiments described above, each of the conductive layer 40, the intermediate metal layer 42, the iridium-containing layer 44, and the iridium oxide layer 46 is formed only on one other material which may lead to overall improved layer-to-layer adhesion by optimizing the deposition process for deposition on a single material. In addition, the electrode 36 may be biocompatible by having only the biocompatible materials exposed, such as the insulating polymer layer 48 and the iridium oxide layer 46, and by not having any non-biocompatible materials exposed, such as the conductive layer 40.

[0036] Various modifications and additions can be made to the exemplary embodiments discussed without departing from the scope of the present invention. For example, while the embodiments described above refer to particular features, the scope of this invention also includes embodiments having different combinations of features and embodiments that do not include all of the described features. Accordingly, the scope of the present invention is intended to embrace all such alternatives, modifications, and variations as fall within the scope of the claims.

35 Claims

1. An electrode (36) for cardiac signal sensing, the electrode (36) comprising:

a conductive layer (40) formed on a portion of a flexible polymer substrate (34);

an intermediate metal layer (42) having a first portion (62) and a second portion (64) and formed on the conductive layer (40);

an iridium-containing layer (44) having a first portion (66) and a second portion (68) and formed on the first portion (62) of the intermediate metal layer (42), wherein the iridium-containing layer (44) includes at least 50 wt. % iridium;

an iridium oxide layer (46) formed on the first portion (62) of the iridium-containing layer (44); and

an insulating polymer layer (48) formed on the second portion (64) of the intermediate metal layer (42), and the second portion (68) of the iridium-containing layer (44),

wherein the iridium-containing layer (44) is not formed on the second portion (64) of the inter-

- mediate metal layer (42); and the iridium oxide layer (46) is not formed on the second portion (68) of the iridium-containing layer (44).
2. The electrode (36) of claim 1, wherein the iridium-containing layer (44) consists of between 50 wt. % and 99 wt. % iridium, and the balance is platinum.
 3. The electrode (36) of claim 1, wherein the iridium-containing layer (44) includes at least 99 wt. % iridium.
 4. The electrode (36) of any of claims 1-3, wherein the insulating polymer layer (48) is a parylene polymer.
 5. The electrode (36) of claim 4, wherein the parylene polymer is selected from the group consisting of poly(p-xylylene), poly(monochloro-p-xylylene), and poly(dichloro-p-xylylene).
 6. The electrode (36) of claim 5, wherein the parylene polymer is poly(monochloro-p-xylylene).
 7. The electrode (36) of any of claims 1-6, wherein the intermediate metal layer (42) includes gold.
 8. A cardiac mapping catheter (10) comprising:
 - an elongate catheter body; and
 - a plurality of splines (30) projecting from an end of the catheter body, the splines (30) flexibly deployable between a radially retracted position and radially extended position, each of the splines (30) including:
 - a flexible polymer substrate (34); and
 - a plurality of electrodes (36) formed on the flexible polymer substrate (34), wherein each of the electrodes (36) is according to any of claims 1-7.
 9. A method for making an electrode (36) for cardiac signal sensing, the electrode (36) formed on a flexible polymer substrate (34) having a conductive layer (40) and an intermediate metal layer (42) disposed on the conductive layer (40), the method comprising:
 - depositing an iridium-containing layer (44) onto a portion of the intermediate metal layer (42), the iridium-containing layer (44) including at least 50 wt. % iridium;
 - depositing an insulating polymer layer (48) on the flexible polymer substrate (34), the conductive layer (40), the intermediate layer (42), and the iridium-containing layer (44);
 - removing the insulating polymer layer (48) from a portion of the iridium-containing layer (44) to form a exposed surface; and
 - electrochemically oxidizing at least a portion of the iridium-containing layer (44) at the exposed surface to form an iridium oxide layer (46) on the iridium-containing layer (44).
 10. The method of claim 9, wherein removing the insulating polymer layer (48) includes laser ablating the insulating polymer layer (48) from the portion of the iridium-containing layer (44).
 11. The method of any of claims 9-10, wherein depositing the insulating polymer layer (48) includes depositing a parylene polymer by vapor deposition.
 12. The method of any of claims 9-11, wherein depositing the iridium-containing layer (44) includes:
 - applying a first mechanical mask (76) to the substrate (34), the first mechanical mask (76) including a first opening aligned with the intermediate metal layer (42) to define the portion of the intermediate metal layer (42);
 - depositing the iridium-containing layer (44) by sputter deposition; and
 - removing the first mechanical mask (76).
 13. The method of any of claims 9-12, wherein removing the insulating polymer layer (48) includes:
 - applying a second mechanical mask (82) to the substrate (34), the second mechanical mask (82) including a second opening aligned with the portion of the iridium-containing layer (44), wherein the second opening is smaller than the first opening;
 - laser ablating the insulating polymer layer (48) from the portion of the iridium-containing layer (44); and
 - removing the second mechanical mask (82).
 14. The method of any of claims 9-12, wherein removing the insulating polymer layer (48) includes:
 - applying a second mechanical mask (82) to the substrate (34), the second mechanical mask (82) including a second opening aligned with the portion of the iridium-containing layer (44), wherein the second opening is about the same size as the first opening;
 - laser ablating the insulating polymer layer (48) from the portion of the iridium-containing layer (44); and
 - removing the second mechanical mask (82).
 15. The method of any of claims 9-14, wherein electrochemically oxidizing includes:
 - immersing the substrate (34) in an electrolytic solution;
 - cycling the iridium-containing layer (44) be-

tween positive and negative voltages until a desired thickness of iridium oxide is formed on the surface of the portion of iridium-containing layer (44); and removing the substrate (34) from the electrolytic solution.

Patentansprüche

1. Elektrode (36) zur Erfassen von Herzsignalen, welche Elektrode (36) aufweist:

eine leitende Schicht (40), die auf einem Bereich eines flexiblen Polymersubstrats (34) gebildet ist;

eine Metallzwischenschicht (42) mit einem ersten Bereich (62) und einem zweiten Bereich (64), die auf der leitenden Schicht (40) gebildet ist;

eine iridiumhaltige Schicht (44) mit einem ersten Bereich (66) und einem zweiten Bereich (68), die auf dem ersten Bereich (62) der Metallzwischenschicht (42) gebildet ist, wobei die iridiumhaltige Schicht (44) zumindest 50 Gew.-% Iridium enthält;

eine Iridiumoxidschicht (46), die auf dem ersten Bereich (62) der iridiumhaltigen Schicht (44) gebildet ist; und

eine isolierende Polymerschicht (48), die auf dem zweiten Bereich (64) der Metallzwischenschicht (42) und dem zweiten Bereich (68) der iridiumhaltigen Schicht (44) gebildet ist, wobei die iridiumhaltige Schicht (44) nicht auf dem zweiten Bereich (64) der Metallzwischenschicht (42) gebildet ist; und die Iridiumoxidschicht (46) nicht auf dem zweiten Bereich (68) der iridiumhaltigen Schicht (44) gebildet ist.

2. Elektrode (36) nach Anspruch 1, bei der die iridiumhaltige Schicht (44) aus zwischen 50 Gew.-% und 99 Gew.-% Iridium und dem Rest aus Platin besteht.

3. Elektrode (36) nach Anspruch 1, bei der die iridiumhaltige Schicht (44) zumindest 99 Gew.-% Iridium enthält.

4. Elektrode (36) nach einem der Ansprüche 1-3, bei der die isolierende Polymerschicht (48) ein Parylenpolymer ist.

5. Elektrode (36) nach Anspruch 4, bei der das Parylenpolymer aus der Gruppe, bestehend aus Poly(p-xylylen), Poly(monochlor-p-xylylen) und Poly(dichlor-p-xylylen), ausgewählt ist.

6. Elektrode (36) nach Anspruch 5, bei der das Parylenpolymer Poly(monochlor-p-xylylen) ist.

7. Elektrode (36) nach einem der Ansprüche 1-6, bei dem die Metallzwischenschicht (42) Gold enthält.

8. Herzabbildungskatheter (10), welcher aufweist:

einen länglichen Katheterkörper; und mehrere Keile (30), die von einem Ende des Katheterkörpers vorstehen, wobei die Keile (30) flexibel entfaltbar sind zwischen einer radial zurückgezogenen Position und einer radial erweiterten Position, und jeder der Keile (30) enthält:

ein flexibles Polymersubstrat (34); und mehrere Elektroden (36), die auf dem flexiblen Polymersubstrat (34) gebildet sind, wobei jede der Elektroden (36) gemäß einem der Ansprüche 1-7 konfiguriert ist.

9. Verfahren zum Herstellen einer Elektrode (36) für die Erfassung von Herzsignalen, wobei die Elektrode (36), die auf einem flexiblen Polymersubstrat (34) gebildet ist, eine leitende Schicht (40) und eine Metallzwischenschicht (42), die auf der leitenden Schicht (40) gebildet ist, hat, welches Verfahren aufweist:

Aufbringen einer iridiumhaltigen Schicht (44) auf einen Bereich der Metallzwischenschicht (42), wobei die iridiumhaltige Schicht (44) zumindest 50 Gew.-% Iridium enthält;

Aufbringen einer isolierenden Polymerschicht (48) auf das flexible Polymersubstrat (34), die leitende Schicht (40), die Zwischenschicht (42) und die iridiumhaltige Schicht (44);

Entfernen der isolierenden Polymerschicht (48) von einem Bereich der iridiumhaltigen Schicht (44), um eine freigelegte Oberfläche zu bilden; und

elektrochemisches Oxidieren zumindest eines Bereichs der iridiumhaltigen Schicht (44) an der freigelegten Oberfläche, um eine Iridiumoxidschicht (46) auf der iridiumhaltigen Schicht (44) zu bilden.

10. Verfahren nach Anspruch 9, bei dem das Entfernen der isolierenden Polymerschicht (48) eine Laserablation der isolierenden Polymerschicht (48) von dem Bereich der iridiumhaltigen Schicht (44) enthält.

11. Verfahren nach einem der Ansprüche 9-10, bei dem das Aufbringen der isolierenden Polymerschicht (48) das Aufbringen eines Parylenpolymers durch Aufdampfen enthält.

12. Verfahren nach einem der Ansprüche 9-11, bei dem das Aufbringen der iridiumhaltigen Schicht (44) enthält:

- Aufbringen einer ersten mechanischen Maske (76) auf das Substrat (34), wobei die erste mechanische Maske (76) eine erste Öffnung enthält, die mit der Metallzwichenschicht (42) ausgerichtet ist, um den Bereich der Metallzwichenschicht (42) zu definieren; Aufbringen der iridiumhaltigen Schicht (44) durch Sputter-Aufbringung; und Entfernen der ersten mechanischen Maske (76).
13. Verfahren nach einem der Ansprüche 9-12, bei dem das Entfernen der isolierenden Polymerschicht (48) enthält:
- Aufbringen einer zweiten mechanischen Maske (82) auf das Substrat (34), wobei die zweite mechanische Maske (82) eine zweite Öffnung enthält, die mit dem Bereich der iridiumhaltigen Schicht (44) ausgerichtet ist, und wobei die zweite Öffnung kleiner als die erste Öffnung ist; Laserablation der isolierenden Polymerschicht (48) von dem Bereich der iridiumhaltigen Schicht (44); und Entfernen der zweiten mechanischen Maske (82).
14. Verfahren nach einem der Ansprüche 9-12, bei dem das Entfernen der isolierenden Polymerschicht (48) enthält:
- Aufbringen einer zweiten mechanischen Maske (82) auf das Substrat (34), wobei die zweite mechanische Maske (82) eine zweite Öffnung enthält, die mit dem Bereich der iridiumhaltigen Schicht (44) ausgerichtet ist, wobei die zweite Öffnung etwa die gleiche Größe wie die erste Öffnung hat; Laserablation der isolierenden Polymerschicht (48) von dem Bereich der iridiumhaltigen Schicht (44); und Entfernen der zweiten mechanischen Maske (82).
15. Verfahren nach einem der Ansprüche 9-14, bei dem das elektrochemische Oxidieren enthält:
- Eintauchen des Substrats (34) in eine Elektrolytlösung; zyklisches Behandeln der iridiumhaltigen Schicht (44) zwischen positiver und negativer Spannung, bis eine gewünschte Dicke von Iridiumoxid auf der Oberfläche des Bereichs der iridiumhaltigen Schicht (44) gebildet ist; und Entfernen des Substrats (34) aus der Elektrolytlösung.

Revendications

- Électrode (36) pour la détection de signaux d'activité cardiaque, l'électrode (36) comprenant :
 - une couche conductrice (40) qui est formée sur une partie d'un substrat en polymère flexible (34) ;
 - une couche en métal intermédiaire (42) qui comporte une première partie (62) et une seconde partie (64) et qui est formée sur la couche conductrice (40) ;
 - une couche contenant de l'iridium (44) qui comporte une première partie (66) et une seconde partie (68) et qui est formée sur la première partie (62) de la couche en métal intermédiaire (42), dans laquelle la couche contenant de l'iridium (44) inclut au moins 50 % en poids d'iridium ;
 - une couche en oxyde d'iridium (46) qui est formée sur la première partie (62) de la couche contenant de l'iridium (44) ; et
 - une couche en polymère isolante (48) qui est formée sur la seconde partie (64) de la couche en métal intermédiaire (42) et sur la seconde partie (68) de la couche contenant de l'iridium (44) ; dans laquelle :
 - la couche contenant de l'iridium (44) n'est pas formée sur la seconde partie (64) de la couche en métal intermédiaire (42) ; et la couche en oxyde d'iridium (46) n'est pas formée sur la seconde partie (68) de la couche contenant de l'iridium (44).
- Électrode (36) selon la revendication 1, dans laquelle la couche contenant de l'iridium (44) est constituée par entre 50 % en poids et 99 % en poids d'iridium, et le complément est du platine.
- Électrode (36) selon la revendication 1, dans laquelle la couche contenant de l'iridium (44) inclut au moins 99 % en poids d'iridium.
- Électrode (36) selon l'une quelconque des revendications 1 à 3, dans laquelle la couche en polymère isolante (48) est un polymère parylène.
- Électrode (36) selon la revendication 4, dans laquelle le polymère parylène est sélectionné parmi le groupe qui est constitué par le poly(p-xylylène), le poly(monochloro-p-xylylène) et le poly(dichloro-p-xylylène).
- Électrode (36) selon la revendication 5, dans laquelle le polymère parylène est le poly(monochloro-p-xylylène).
- Électrode (36) selon l'une quelconque des revendications 1 à 6, dans laquelle la couche en métal intermédiaire (42) inclut de l'or.

8. Cathéter de cartographie d'activité cardiaque (10) comprenant :

un corps de cathéter allongé ; et
une pluralité de cannelures (30) qui font saillie depuis une extrémité du corps de cathéter, les cannelures (30) pouvant être déployées de manière flexible entre une position rétractée radialement et une position étendue radialement, chacune des cannelures (30) incluant :

un substrat en polymère flexible (34) ; et
une pluralité d'électrodes (36) qui sont formées sur le substrat en polymère flexible (34), dans lequel chacune des électrodes (36) est selon l'une quelconque des revendications 1 à 7.

9. Procédé pour fabriquer une électrode (36) pour la détection de signaux d'activité cardiaque, l'électrode (36) étant formée sur un substrat en polymère flexible (34) qui comporte une couche conductrice (40) et une couche en métal intermédiaire (42) qui est disposée sur la couche conductrice (40), le procédé comprenant :

le dépôt d'une couche contenant de l'iridium (44) sur une partie de la couche en métal intermédiaire (42), la couche contenant de l'iridium (44) incluant au moins 50 % en poids d'iridium ;
le dépôt d'une couche en polymère isolante (48) sur le substrat en polymère flexible (34), sur la couche conductrice (40), sur la couche en métal intermédiaire (42) et sur la couche contenant de l'iridium (44) ;
l'enlèvement de la couche en polymère isolante (48) au niveau d'une partie de la couche contenant de l'iridium (44) de manière à former une surface exposée ; et
l'oxydation électrochimique d'au moins une partie de la couche contenant de l'iridium (44) au niveau de la surface exposée de manière à former une couche en oxyde d'iridium (46) sur la couche contenant de l'iridium (44).

10. Procédé selon la revendication 9, dans lequel l'enlèvement de la couche en polymère isolante (48) inclut une ablation par laser de la couche en polymère isolante (48) au niveau de la partie de la couche contenant de l'iridium (44).

11. Procédé selon l'une quelconque des revendications 9 et 10, dans lequel le dépôt de la couche en polymère isolante (48) inclut le dépôt d'un polymère parylène au moyen d'un dépôt en phase vapeur.

12. Procédé selon l'une quelconque des revendications 9 à 11, dans lequel le dépôt de la couche contenant

de l'iridium (44) inclut :

l'application d'un premier masque mécanique (76) sur le substrat (34), le premier masque mécanique (76) incluant une première ouverture qui est alignée avec la couche en métal intermédiaire (42) de manière à définir la partie de la couche en métal intermédiaire (42) ;
le dépôt de la couche contenant de l'iridium (44) au moyen d'un dépôt par pulvérisation ; et
l'enlèvement du premier masque mécanique (76).

13. Procédé selon l'une quelconque des revendications 9 à 12, dans lequel l'enlèvement de la couche en polymère isolante (48) inclut :

l'application d'un second masque mécanique (82) sur le substrat (34), le second masque mécanique (82) incluant une seconde ouverture qui est alignée avec la partie de la couche contenant de l'iridium (44), dans lequel la seconde ouverture est plus petite que la première ouverture ;
l'ablation par laser de la couche en polymère isolante (48) au niveau de la partie de la couche contenant de l'iridium (44) ; et
l'enlèvement du second masque mécanique (82).

14. Procédé selon l'une quelconque des revendications 9 à 12, dans lequel l'enlèvement de la couche en polymère isolante (48) inclut :

l'application d'un second masque mécanique (82) sur le substrat (34), le second masque mécanique (82) incluant une seconde ouverture qui est alignée avec la partie de la couche contenant de l'iridium (44), dans lequel la seconde ouverture présente approximativement la même dimension que la première ouverture ;
l'ablation par laser de la couche en polymère isolante (48) au niveau de la partie de la couche contenant de l'iridium (44) ; et
l'enlèvement du second masque mécanique (82).

15. Procédé selon l'une quelconque des revendications 9 à 14, dans lequel l'oxydation électrochimique inclut :

l'immersion du substrat (34) dans une solution électrolytique ;
le cyclage de la couche contenant de l'iridium (44) entre des tensions positive et négative jusqu'à ce qu'une épaisseur souhaitée d'oxyde d'iridium soit formée sur la surface de la partie de la couche contenant de l'iridium (44) ; et
l'enlèvement du substrat (34) hors de la solution

électrolytique.

5

10

15

20

25

30

35

40

45

50

55

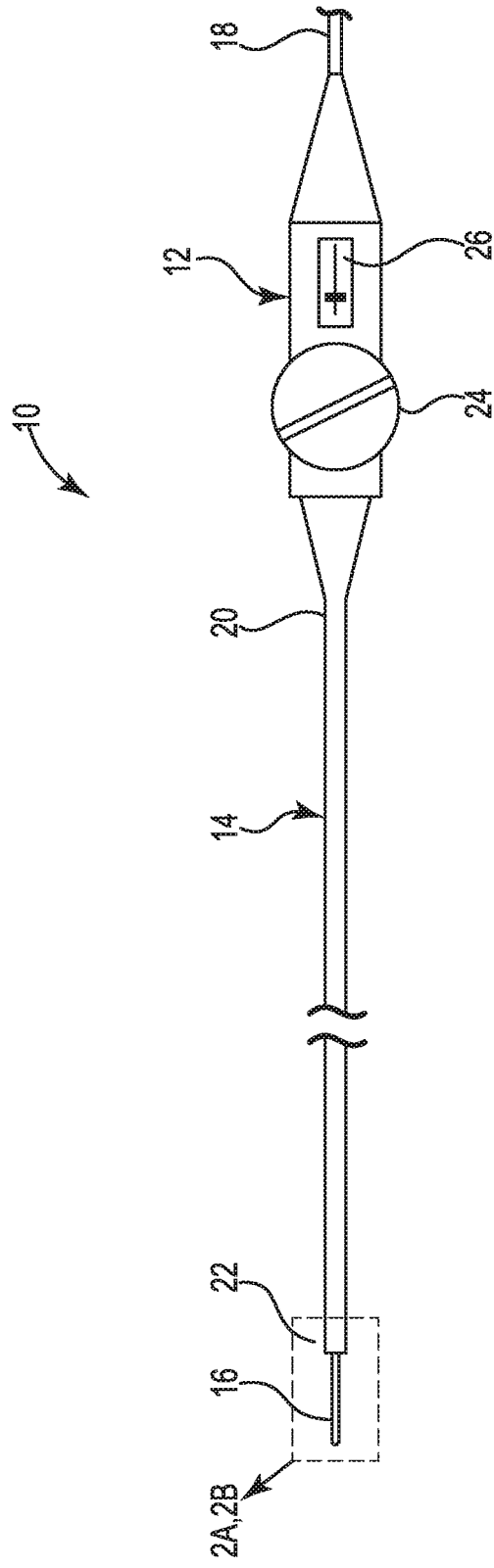

Fig. 1

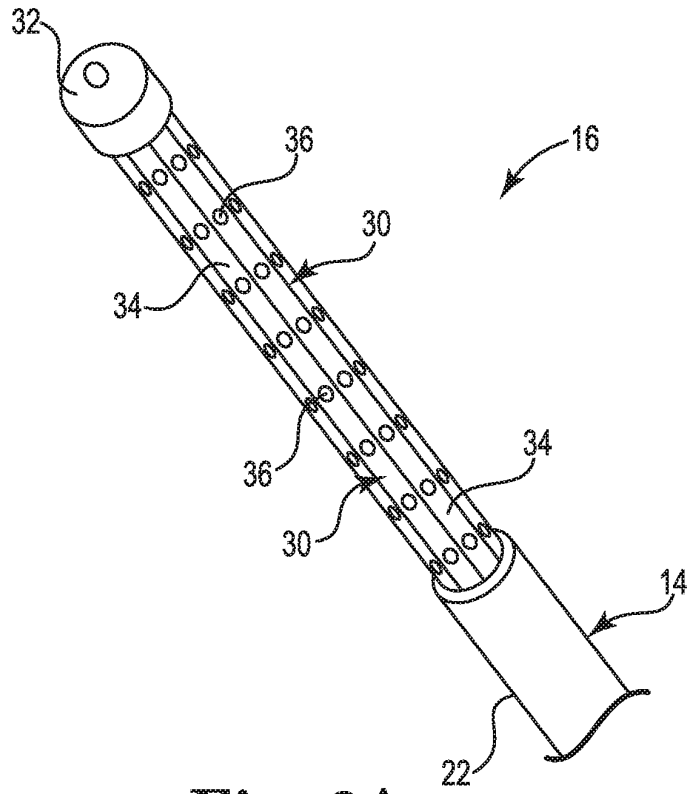

Fig. 2A

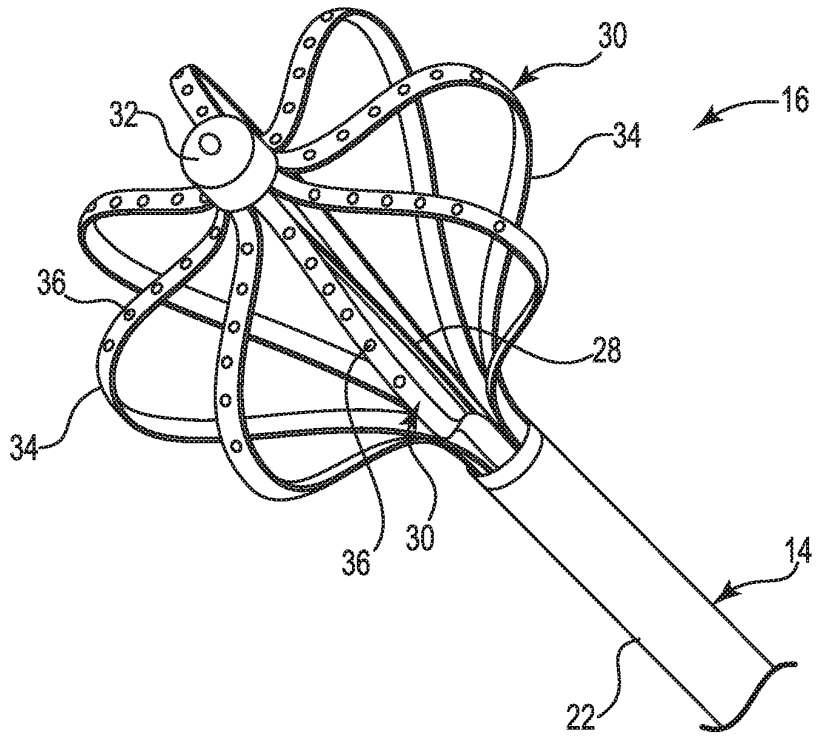

Fig. 2B

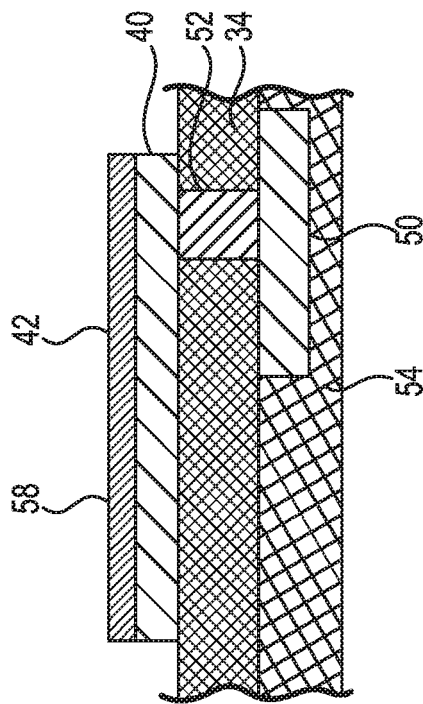

Fig. 4

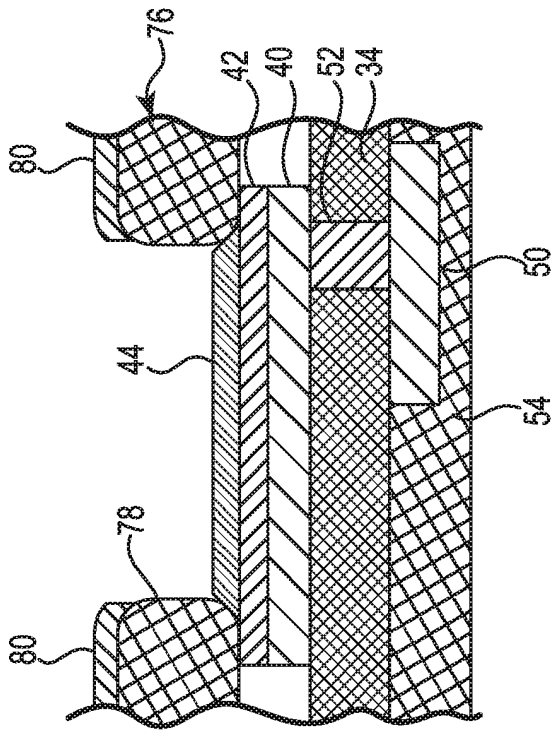

Fig. 6

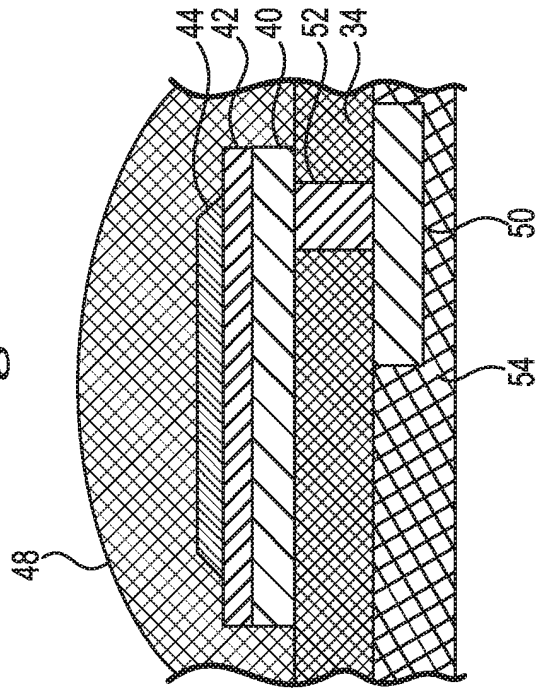

Fig. 8

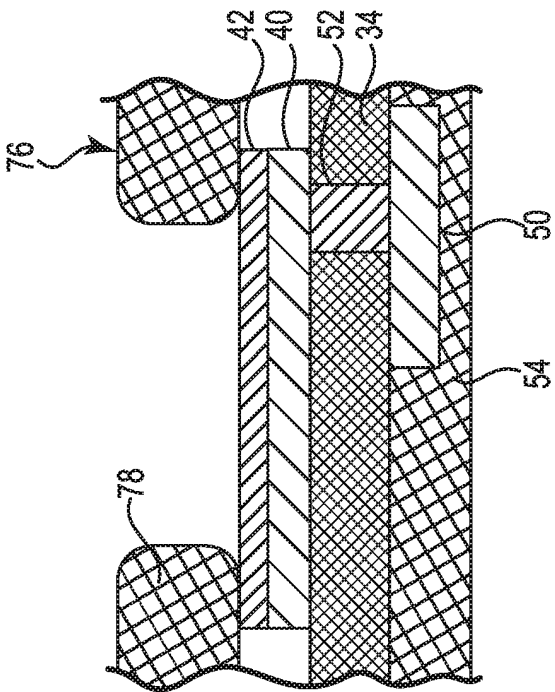

Fig. 5

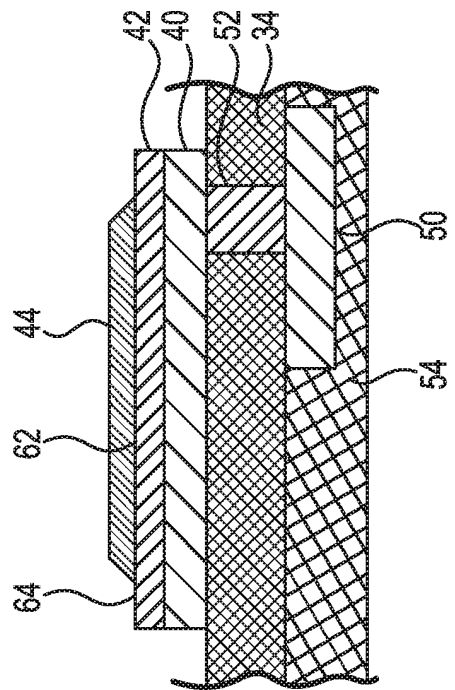

Fig. 7

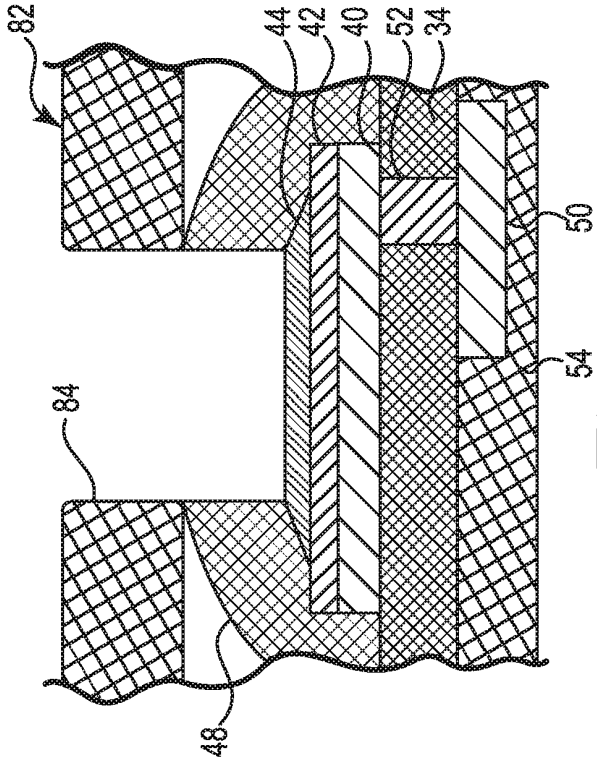

Fig. 10

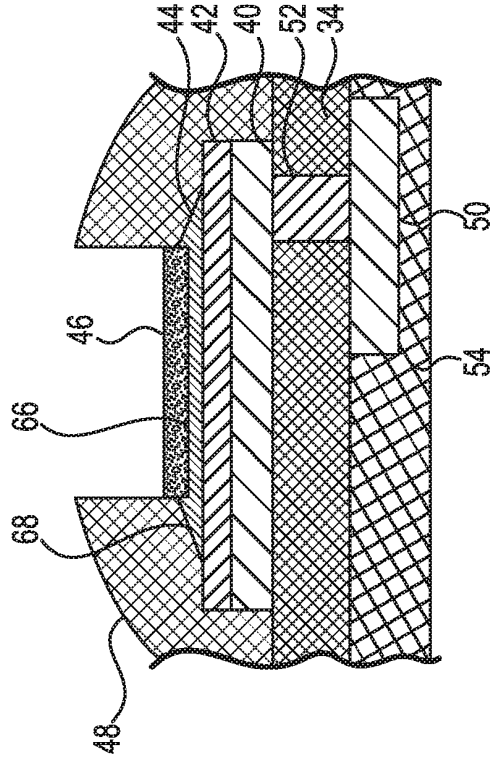

Fig. 12

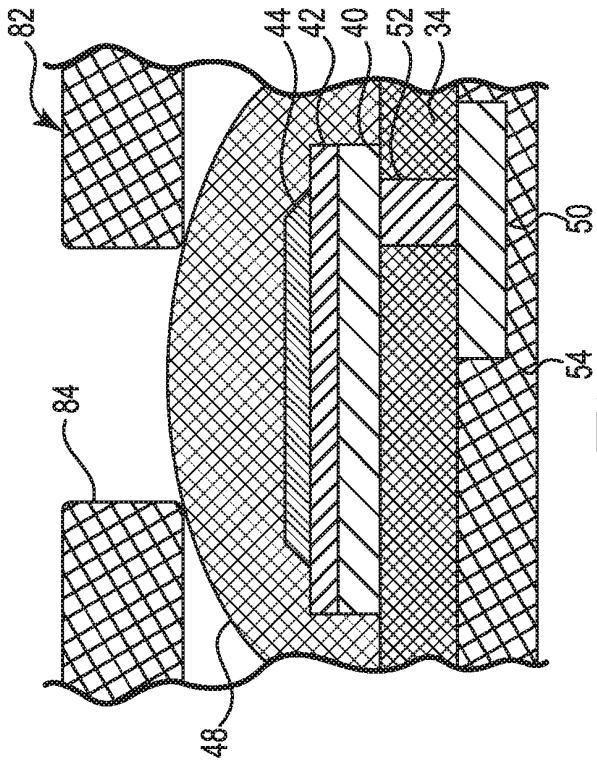

Fig. 9

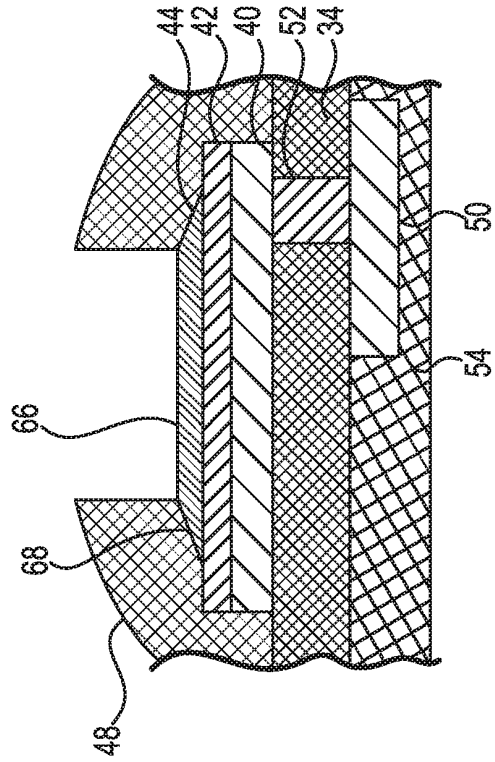

Fig. 11

REFERENCES CITED IN THE DESCRIPTION

This list of references cited by the applicant is for the reader's convenience only. It does not form part of the European patent document. Even though great care has been taken in compiling the references, errors or omissions cannot be excluded and the EPO disclaims all liability in this regard.

Patent documents cited in the description

- US 2014262462 A1 [0004]
- US 2009293270 A1 [0004]
- US 2010230285 A1 [0004]
- US 2013253298 A1 [0004]
- US 2004220652 A1 [0004]
- US 8447377 B [0010]

专利名称(译)	用于心脏感应的柔性电极及其制造方法		
公开(公告)号	EP3337387B1	公开(公告)日	2019-09-25
申请号	EP2016758020	申请日	2016-08-17
[标]申请(专利权)人(译)	波士顿科学西美德公司		
申请(专利权)人(译)	BOSTON SCIENTIFIC SCIMED INC.		
当前申请(专利权)人(译)	BOSTON SCIENTIFIC SCIMED INC.		
[标]发明人	GUNTER KENNETH L FRANKSON DANIELLE MERRIAM PATRICK A MAIERHOFER EDWARD J JONES MATTHEW P		
发明人	SALLEE, GREGORY GUNTER, KENNETH L. FRANKSON, DANIELLE MERRIAM, PATRICK A. MAIERHOFER, EDWARD J. JONES, MATTHEW P.		
IPC分类号	A61B5/00 A61B5/042		
优先权	62/207814 2015-08-20 US		
其他公开文献	EP3337387A1		
外部链接	Espacenet		

摘要(译)

用于心脏信号感测的电极包括在柔性聚合物基板上形成的中间层，含钛层，氧化钛层，绝缘聚合物层和导电层。中间金属层具有第一部分和第二部分，并且形成在导电层上。含钛层包括至少50重量%的钛，并且形成在中间金属层的第一部分上。氧化钛层形成在含钛层的第一部分上。绝缘聚合物层形成在中间金属层的第二部分和含钛层的第二部分上。在中间金属层的第二部分上不形成含钛层；并且在含钛层的第二部分上不形成氧化钛层。

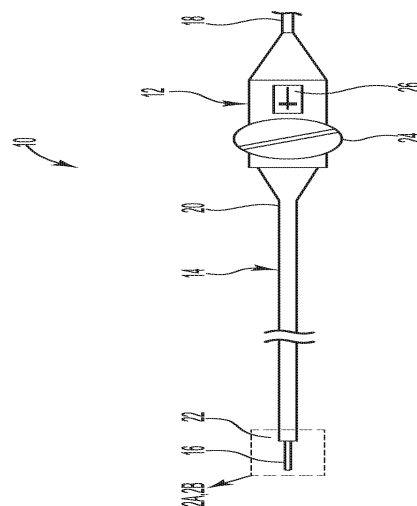

Fig. 1