

(19)



(11)

EP 2 823 834 B1

(12)

EUROPEAN PATENT SPECIFICATION

(45) Date of publication and mention of the grant of the patent:
22.06.2016 Bulletin 2016/25

(51) Int Cl.:
A61M 1/36^(2006.01) A61B 5/00^(2006.01)
A61B 5/021^(2006.01)

(21) Application number: **13175841.9**

(22) Date of filing: **10.07.2013**

(54) Apparatus for extracorporeal blood treatment

Vorrichtung zur extrakorporalen Blutbehandlung

Appareil de traitement extracorporel du sang

(84) Designated Contracting States:
AL AT BE BG CH CY CZ DE DK EE ES FI FR GB GR HR HU IE IS IT LI LT LU LV MC MK MT NL NO PL PT RO RS SE SI SK SM TR

(43) Date of publication of application:
14.01.2015 Bulletin 2015/03

(73) Proprietor: **Gambro Lundia**
22010 Lund (SE)

(72) Inventors:
• **Stefani, David**
41125 Modena (IT)

• **Ruffo, Mariano**
41125 Modena (IT)

(74) Representative: **Ponzellini, Gianmarco et al**
PGA S.r.l.
Via Mascheroni, 31
20145 Milano (IT)

(56) References cited:
WO-A1-03/002174 WO-A1-2008/006559
WO-A1-2012/175267 WO-A1-2013/000777
DE-A1- 10 033 192 US-A1- 2011 301 472

EP 2 823 834 B1

Note: Within nine months of the publication of the mention of the grant of the European patent in the European Patent Bulletin, any person may give notice to the European Patent Office of opposition to that patent, in accordance with the Implementing Regulations. Notice of opposition shall not be deemed to have been filed until the opposition fee has been paid. (Art. 99(1) European Patent Convention).

Description

Field of Invention

[0001] The present invention relates to an apparatus for extracorporeal blood treatment and also to a related control method of the apparatus.

Background of Invention

[0002] The known extracorporeal blood treatment apparatus comprise at least a treatment unit (for example a dialyser or filter or an ultrafilter or a plasma filter or a filter unit of a different type) having a semi-permeable membrane which separates the treatment unit into two chambers. An extracorporeal blood circuit enables circulation of blood taken from a patient within the first chamber. At the same time, and typically in a countercurrent direction with respect to the blood, a treatment fluid is circulated across a special circuit in the second chamber of the treatment unit. A blood removal line is connected with an inlet port of the first chamber and is predisposed, in operating conditions of connection to a patient, to remove blood from a vascular access inserted, for example, in a fistula on the patient. A blood return line connected with an outlet port of the first chamber is predisposed to receive the blood treated by the treatment unit and to return the treated blood to a further vascular access connected to the patient's fistula. A peristaltic pump operatively coupled to the extracorporeal blood circuit circulates the blood in the circuit. This type of blood treatment apparatus, known as dialysis apparatus, can be used for removal of solutes and excess fluid from the patient's blood where the patient is suffering from kidney failure.

[0003] During this treatment it is necessary to monitor and analyse the behaviour of the patient's physiological pressure generators, such as the heart and/or the breathing system. For example, to monitor the heartbeat of a subject, the blood pressure and also the state of the vascular accesses (for example to identify the dislodgement of the venous needle VND), it is advisable to extract/isolate the pressure data deriving from the physiological pressure generators. To this end the pressure signals detected by special sensors arranged in the extracorporeal blood circuit must be treated/filtered in order to remove noise.

[0004] Document US 2011/301472 discloses a method for determining and/or monitoring quantities, in particular cardiovascular quantities, relating to a patient's condition, and an apparatus for measuring an amplitude of a cardiac pressure signal. The amplitude of the pressure signal is detected with the aid of a pressure sensor of a blood treatment apparatus, and its magnitude is corrected by the contribution of the blood pump of the blood treatment apparatus to determine the amplitude of the cardiac pressure signal of the patient.

[0005] Document WO 2013/000777, in the name of the

same Applicant, relates to processing of a time-dependent pressure signal obtained from a fluid containing system for removal of a signal component originating from a specific pulse generator. The fluid containing system may include an extracorporeal blood flow circuit. The above-mentioned pressure signal contains both an information component, e.g. pressure variations representing heart pulses, and a disturbance component, e.g. pressure variation caused by a blood pump. A device removes first pulses in the pressure signal of a pressure sensor which is arranged in the fluid containing system to detect the first pulses, which originate from a first pulse generator, and second pulses, which originate from a second pulse generator. The device repetitively obtains a current data sample, calculates a reference value and subtracts the reference value from the current data sample. The reference value is calculated as a function of other data sample in the same pressure signal. Document DE 100 33 192 discloses a method for detecting arterial flow problems during extracorporeal blood treatment. Said method measures, in the venous blood duct, the amplitude of the periodical variations of pressure which are caused by the rotations of the blood pump and compares it to a threshold value. If the threshold value is exceeded, problems are deduced.

[0006] WO 2008/006559, WO 03/002174 and WO 2012/175267 are further documents disclosing devices and methods for monitoring pressure in an extracorporeal blood circuit.

[0007] The Applicant has observed that the existing and known solutions operating the treatment/filtering operations require large memory capacity and computational power in order to process the pressure signals in the most efficient way with the aim of guaranteeing the correct functioning of the apparatus and the respect of the treatment parameters of the patient.

[0008] In particular, the Applicant has observed that the performance of the algorithms at the base of the treatment of pressure signals is negatively influenced by the fact that the sampling frequency of the pressure signals is constant so that the samples acquired in a rotation of the pump decrease as the rotation velocity of the pump increases, and vice versa.

Summary

[0009] In this context, an aim of the present invention is to provide a blood treatment apparatus able to monitor and analyse the behaviour of physiological pressure generators of the patient in a correct and functional way.

[0010] A particular aim of the present invention is to provide an apparatus that is able to efficiently extract/isolate the pressure data deriving from the physiological pressure generator.

[0011] A further aim of the present invention is to provide an apparatus able to carry out processing of the pressure data in a simple way, i.e. without excessive computational effort, and thus also reliably.

[0012] A further aim of the present invention is to provide an apparatus able to carry out the data processing operations with simple and economical hardware and software.

[0013] A further aim of the present invention is to provide an apparatus able to carry out data processing operations requiring only a minimum updating of the hardware and software with respect to those already present in existing apparatus.

[0014] At least one of the above-indicated aims is substantially attained by a blood treatment apparatus according to one or more of the accompanying claims.

[0015] Aspects of the invention are illustrated in the following.

[0016] In an independent first aspect of the invention, an apparatus is described for extracorporeal blood treatment comprising:

- at least a treatment unit (3) having at least a first chamber (4) and at least a second chamber (5) separated from one another by a semi-permeable membrane (6);
- at least a blood removal line (7) connected to an inlet port (4a) of the first chamber (4) and predisposed to remove blood from a patient (P);
- at least a blood return line (8) connected to an outlet port (4b) from the first chamber (4) and predisposed to return treated blood to the patient (P), wherein the blood removal line (7), the blood return line (8) and the first chamber (4) are part of an extracorporeal blood circuit (2);
- at least a peristaltic pump (9) operating at the extracorporeal blood circuit (2) for moving the blood in the circuit (2);
- at least a pressure sensor (13, 14) associated to the extracorporeal blood circuit (2) and configured to enable determination of pressure values in said extracorporeal blood circuit (2);
- at least a fluid drainage line (23) connected to an outlet port of said second chamber (5);
- a control unit (CU) connected to said at least a pressure sensor (13, 14) and to the peristaltic pump (9) and configured to:
 - move the peristaltic pump (9) with a cyclic motion to generate a blood flow;
 - receive from said at least a pressure sensor (13, 14) a signal (Ps) indicating the pressure of the blood in the extracorporeal blood circuit (2);
 - sample, for each cycle of the peristaltic pump (9), the signal (Pr) indicating the blood pressure with a frequency in the time domain depending on the velocity (ω) of the peristaltic pump (9).

[0017] In a second aspect of the invention a sampling method of pressure signals in extracorporeal blood treatment apparatus is provided, the apparatus comprising:

- at least a treatment unit (3) having at least a first chamber (4) and at least a second chamber (5) separated from one another by a semi-permeable membrane (6);
- at least a blood removal line (7) connected to an inlet port (4a) of the first chamber (4) and predisposed to remove blood from a patient (P);
- at least a blood return line (8) connected to an outlet port (4b) from the first chamber (4) and predisposed to return treated blood to the patient (P), wherein the blood removal line (7), the blood return line (8) and the first chamber (4) are part of an extracorporeal blood circuit (2);
- at least a peristaltic pump (9) operating at the extracorporeal blood circuit (2) for moving the blood in the circuit (2);
- at least a pressure sensor (13, 14) associated to the extracorporeal blood circuit (2) and configured to enable determination of pressure values in the extracorporeal blood circuit (2);
- at least a fluid drainage line (23) connected to an outlet port of the second chamber (5);

wherein the method comprises:

- moving the peristaltic pump (9) with a cyclic motion to generate a blood flow;
- receiving from said at least a pressure sensor (13, 14) a signal (Ps) indicating the pressure of the blood in the extracorporeal blood circuit (2);
- sampling, for each cycle of the peristaltic pump (9), the signal (Ps) indicating the blood pressure with a frequency in the time domain depending on the velocity (ω) of the peristaltic pump (9).

[0018] In an aspect, the signal (Pr) indicating the blood pressure is detected when the peristaltic pump (9) is in a plurality of predefined positions (pp_1 - pp_y).

[0019] In other words, the detecting instants of the pressure signal coincide with the passage of the peristaltic blood pump through a plurality of predefined positions (pp_1 - pp_y) during the cyclic motion thereof.

[0020] Therefore, as the velocity (ω) of the pump (9) is not constant, the sampling of the pressure signal (or signals) is carried out with a variable frequency over time since it depends on the velocity of the peristaltic blood pump (9).

[0021] From another point of view according to the invention, the pressure signal is sampled at a constant frequency in the spatial domain (constant for each pump cycle) while previously (known art) the sampling of the data was done at a constant frequency in the time domain.

[0022] In the invention, the number of samples acquired in a rotation of the pump is constant and does not depend on the actual rotating velocity of the pump.

[0023] In this way the sampling takes account of the

state of the blood circuit which also depends on the position of the peristaltic blood pump and the velocity thereof.

[0024] In a 3rd aspect according to any one of the preceding aspects, the predefined positions (pp_1 - pp_y) are spatially equidistant. The cyclic pathway the peristaltic pump follows is sub-divided by the predefined positions (pp_1 - pp_y) in linear or angular spatial intervals of equal entity.

[0025] In a 4th aspect according to any one of the preceding aspects, the predefined positions are in a number "y" where "y" is greater than or equal to fifty, for instance greater than one hundred, for instance equal to one hundred and twenty.

[0026] This number is sufficient to ensure a sampling frequency (variable over time) to correctly represent the progression of the pressure signal.

[0027] In a 5th aspect according to any one of the preceding aspects, the apparatus comprises at least a position sensor (32) associated to the peristaltic pump (9) and configured to determine positions of the peristaltic pump (9);

wherein the control unit (CU) is configured to carry out the sampling step which comprises:

- receiving from the position sensor (32) a succession of "n" reference signals (sr_1 - sr_n) indicating reference positions (pr_1 - pr_n) of the peristaltic pump (9);
- determining the signal (Ps) indicating the blood pressure every "m" reference signals (sr_1 - sr_n), where "m" is equal to or greater than one and less than or equal to "n".

[0028] In other words, the reference signals (sr_1 - sr_n) generated in a pump cycle can all be used to command detection of the signal (Ps) indicating the pressure or only one every "m". The "n/m" ratio is therefore equal to "y". If all are used, the reference positions are predefined positions, otherwise only a part of the reference positions are predefined positions.

[0029] In a 6th aspect according to the fifth aspect, "n" is greater than or equal to fifty, for instance greater than or equal to five hundred, for instance equal to nine hundred and sixty.

[0030] In a 7th aspect according to the fifth or sixth aspect, "m" is smaller than ten, for instance equal to eight.

[0031] If the "n" reference signals are nine hundred and sixty and "m" is eight, the signal (Ps) indicating the blood pressure is sampled one hundred and twenty times (the number "y" of predefined positions) for each cycle of the peristaltic pump.

[0032] In an 8th aspect according to any one of the preceding aspects, the peristaltic pump (9) is a rotary pump. The predefined positions (p_1 - p_y) are angular positions of the peristaltic pump.

[0033] In a 9th aspect according to any one of aspects from 1 to 7, the peristaltic pump (9) is of a linear type. This type of pump comprises a plurality of pumping ele-

ments (arms arranged and actuated sequentially such as to engage and squeeze successive portions of tube which the pump engages) or possibly other actuators able to generate a pulsating motion in the blood, i.e. a non-constant flow that oscillates about a mean flow value. The predefined positions (p_1 - p_y) are linear positions of the peristaltic pump.

[0034] In a 10th aspect according to any one of aspects from one to eight, the position sensor (32) comprises a phonic wheel coupled to the peristaltic pump (9).

[0035] In an 11th aspect according to the tenth aspect, a rotor (34) of the phonic wheel (32) rotates, for instance solidly, with the peristaltic pump (9). A pickup (34) of the phonic wheel (32) is fixed with respect to a frame of the apparatus (1) and moves with respect to the pump (9) and the rotor (33).

[0036] In a 12th aspect according to the tenth aspect, a rotor (34) of the phonic wheel (32) is fixed and a pickup (34) is mounted on the rotary pump (9).

[0037] According to both the eleventh and twelfth aspects, the rotor (33) of the phonic wheel (32) bears "n" signs (r_1 - r_n) corresponding to the "n" reference signals (sr_1 - sr_n).

[0038] This is a very simple and effective system for detecting the angular position of the peristaltic pump and, possibly, also the angular velocity thereof.

[0039] In a 13th aspect according to aspects 10, 11 or 12, the phonic wheel (32) is of the inductive type. The rotor (33) exhibits a plurality of prominences or teeth ("n" signs (r_1 - r_n)) made of a ferromagnetic material and a proximity sensor (34, pickup) facing the rotor (33) detects the flow variation in the magnetic field due to the passage of the prominences. The flow variation creates an induced alternating pulsating current and each pulse corresponds to a prominence.

[0040] In a 14th aspect according to aspects 10, 11 or 12, the phonic wheel (32) is capacitive. The rotor exhibits a plurality of prominences or teeth ("n" signs (r_1 - r_n)) connected to an electric line and the sensor (pickup) is a contact pole touched by the rotating teeth. Each tooth corresponds to an instantaneous closing of the circuit, with a consequent electric pulse, followed immediately by the re-opening of the contact.

[0041] In a 15th aspect according to aspects 10, 11, or 12, the phonic wheel (32) is of an optic type. The rotor comprises sectors of opaque material alternated with sectors of reflective material ("n" signs (r_1 - r_n)). A laser strikes the rotor and a return sensor (pickup) detects the reflected laser beam from the rotor. The opaque material completely absorbs the laser while the reflective material returns it as a reflection, and a signal corresponds to each passage from opaque to reflective.

[0042] The control unit (CU) receives, from the pickup (34), the succession of "n" reference signals (sr_1 - sr_n) and samples the signal (Ps) indicating the blood pressure every "m" reference signals, where "m" is equal to or greater than one. In other words, not all the "n" reference signals (sr_1 - sr_n) of the phonic wheel (32) are used as

commands for detecting the pressure signal, but only one every "m".

[0043] In a 16th aspect according to any one of the preceding aspects, the control unit (CU) is configured to:

- receive a signal (ω , Fr) indicating the instant blood flow (Qb) in the peristaltic pump (9);
- compare the signal (ω , Fr) with a plurality of fields ($\Delta\omega_1-\Delta\omega_j$, $\Delta Fr_1-\Delta Fr_j$) indicating predefined intervals of blood flow ($\Delta Qb_1-\Delta Qb_j$) each combined with a respective predefined sampling frequency (Fs_1-Fs_j) of the signal (Ps) indicating the blood pressure;
- identify the field ($\Delta\omega_k$, ΔFs_k) in the plurality of fields ($\Delta\omega_1-\Delta\omega_j$, $\Delta Fr_1-\Delta Fr_j$) to which the signal belongs (ω , Fr);
- identify the respective predefined sampling frequency (Fs_k);
- dimension a filter to be used on the basis of the predefined sampling frequency (Fs_k) and at a desired cutting frequency (Fc);
- apply the filter to the sampled signal (Ps) indicative of the blood pressure.

[0044] In accordance with the instant value measured by the blood flow "Qb", the control unit "CU" uses one of the filters and changes the filter when the instant value measured by the blood flow "Qb" during the treatment falls within a different interval.

[0045] In a 17th aspect according to the 16th aspect, the signal (ω , Fr) indicating the instant blood flow (Qb) is a cyclic velocity (ω), for instance angular, of the peristaltic pump (9). In an 18th aspect according to the 17th aspect, the cyclic velocity (ω) is calculated through the phonic wheel (32).

[0046] In a 19th aspect according to the 17th aspect, (ω) is detected through a device distinct from the phonic wheel, for example a Hall-effect sensor which detects the passage of lobes (15) of the pump (9).

[0047] In a 20th aspect according to the 17th, 18th or 19th aspect, the cyclic velocity (ω) is an average calculated on each cycle of the peristaltic pump (9).

[0048] In a 21st aspect according to the 20th aspect, the cyclic velocity (ω) is calculated by:

- supplying a first counter with the "n" reference signals of the phonic wheel (32) corresponding to a 360° rotation;
- increasing a second time counter (for instance every 2ms) until the first counter reaches the n-th signal;
- considering the inverse of the time used to perform the rotation (time-cycle ΔT given by the second counter) for obtaining the cyclic velocity (ω) in [cycles/s].

[0049] In a 22nd aspect according to aspects 17, 18, 19 or 20, 21, the fields ($\Delta\omega_1-\Delta\omega_j$, $\Delta Fr_1-\Delta Fr_j$) indicating the predefined blood flow ($\Delta Qb_1-\Delta Qb_j$) are cyclic velocity fields ($\Delta\omega_1-\Delta\omega_j$), for instance angular velocity fields.

[0050] Given the volume of blood (Sv) moved by the

peristaltic pump in a complete cycle in [ml/cycle] and given the velocity (ω) of the peristaltic pump in [cycle/s], the flow (Qb) of the peristaltic pump in [ml/min] is given by the relation: $Qb = \omega \times Sv \times 60$.

5 **[0051]** The predefined sampling frequency (Fs_k) is the one associated to the field ($\Delta\omega_k$) among the cyclic velocity fields ($\Delta\omega_1-\Delta\omega_j$) in which the detected cyclic velocity (ω), corresponding to the instant blood flow (Qb), falls.

10 **[0052]** In a 23rd aspect according to the 16th aspect, the signal (ω , Fr) indicating the instant blood flow (Qb) is a frequency (Fr) of reference signals (sr_1-sr_n) indicating positions of the peristaltic pump (9).

15 **[0053]** In a 24th aspect according to the 23rd aspect, the frequency (Fr) of the reference signals (sr_1-sr_n) is an average calculated on each cycle of the peristaltic pump (9).

20 **[0054]** In a 25th aspect according to aspects 23 or 24, the fields ($\Delta\omega_1-\Delta\omega_j$, $\Delta Fr_1-\Delta Fr_j$) indicating the predefined blood flow intervals ($\Delta Qb_1-\Delta Qb_j$) are frequency fields ($\Delta Fr_1-\Delta Fr_j$) of reference signals (sr_1-sr_n) indicating positions of the peristaltic pump.

25 **[0055]** Given the volume of blood (Sv) moved by the peristaltic pump (9) in a complete cycle in [ml/cycle], given the frequency (Fr) of the reference signals (n') indicating the positions of the peristaltic pump (9) in [1/s] and given the number of the reference signals (n, acquired points) in a complete cycle of the peristaltic pump (9), the flow (Qb) of the peristaltic pump (9) in [ml/min] is given by the relation: $Qb = Fr \times (Sv \times 60)/n'$.

30 **[0056]** The predefined sampling frequency (Fs_k) is the one associated with that field (ΔFr_k), among the frequency fields ($\Delta Fr_1-\Delta Fr_j$) of the reference signals (sr_1-sr_n), in which the detected frequency (Fr) of the reference signals (sr_1-sr_n), corresponding to the instant blood flow (Qb), falls.

35 **[0057]** In a 26th aspect according to aspects 23 and/or 24 and/or 25, the frequency (Fr) of the reference signals (sr_1-sr_n) corresponds to the sampling frequency (Fs) of the signal (Ps) indicating the blood pressure. In this case the reference signals (n') taken into consideration between the (n) reference signals are only those of the predefined positions (y) of the peristaltic pump ($n' = y$). Given the number of the predefined positions (y) and the time-cycle (ΔT) of the peristaltic pump, the frequency (Fr) of the reference signals is given by the relation: $Fr = Fs = y/\Delta T$.

40 **[0058]** In a 27th aspect according to aspects 23 and/or 24 and/or 25, the frequency (Fr) of the reference signals (sr_1-sr_n) corresponds to a multiple of the sampling frequency (Fs) of the signal (Ps) indicating the blood pressure. In this case, the reference signals (n') taken into consideration among the (n) reference signals are all those (n) reference signals or a multiple (X) of those corresponding to the predefined positions (y) of the peristaltic pump ($n' = X \times n$). For example, considering all the (n) reference signals and the time-cycle (ΔT) of the peristaltic pump, the frequency (Fr) of the reference signals is given by the relation: $Fr = n/\Delta T$ where $n=m \times y$ so that $Fr = m$

x Fs.

[0059] In a 28th aspect according to aspects 26 or 27, the frequency (Fr) of the reference signals (sr_1 - sr_n) is calculated by:

- supplying a first counter with the (n') reference signals taken into consideration among the (n) reference signals (sr_1 - sr_n) corresponding to a rotation of 360°;
- increasing a second time counter (for instance every 2ms) until the first counter reaches the n'-th signal;
- dividing the number (n') of reference signals (sr_1 - sr_n) taken into consideration for the time-cycle ΔT (given by the second counter) for obtaining the frequency (Fr) in [1/s].

[0060] In a 29th aspect according to one or more of aspects from 16 to 28, each predefined sampling frequency (Fs_1 - Fs_j) corresponds to a predefined value (Qb_1 - Qb_j) of the respective predefined blood flow interval (ΔQb_1 - ΔQb_j).

[0061] In an aspect, the predefined value (Qb_1 - Qb_j) is a median value of the respective predefined blood flow interval (ΔQb_1 - ΔQb_j).

[0062] Using the predefined value (Qb_1 - Qb_j) of each of the flow intervals (ΔQb_1 - ΔQb_j), a calculation is made of one of the predefined sampling frequency values (Fs_1 - Fs_j) using the formula:

$$Fs = Qb \times (y/Sv \times 60)$$

where (Sv) is the blood volume moved by the peristaltic pump in a complete cycle in [ml/cycle] and (y) is the number of predefined positions.

[0063] To each predefined value (Qb_1 - Qb_j) of each of the flow intervals (ΔQb_1 - ΔQb_j) corresponds a predefined cyclic velocity value (ω_1 - ω_j) of each of the cyclic velocity fields ($\Delta\omega_1$ - $\Delta\omega_j$) and a predefined frequency value (Fr_1 - Fr_j) of the reference signals of the frequency fields (ΔFr_1 - ΔFr_j) of the reference signals (sr_1 - sr_n).

[0064] In a 30th aspect according to the 29th aspect, the predetermined sampling frequency values (Fs_1 - Fs_j) can be calculated directly by the predefined values (median) of cyclic velocity (ω_1 - ω_j) using the relation:

$$Fs = \omega \times y$$

or by the predefined values (median) of frequency (Fr_1 - Fr_j) of the reference signals with the relation:

$$Fs = Fr \times y/n$$

[0065] If the frequency (Fr) of the reference signals is the sampling frequency (Fs) of the signal (Ps) indicating

the blood pressure, then the predefined values (median) of frequency (Fr_1 - Fr_j) of the reference signals are the predefined sampling frequency value (Fs_1 - Fs_j). In a 31st aspect according to one or more of the aspects from 16 to 30, the number (j) of predefined intervals of blood flow (ΔQb_1 - ΔQb_j) is comprised between two and five, for instance either three or four. To each of the intervals (ΔQb_1 - ΔQb_j) corresponds a predefined sampling frequency (Fs_1 - Fs_j). By containing the number of intervals/frequency of sampling, the computational weight is reduced for the calculation of the filters. This choice is an excellent compromise between simplicity of calculation and uncertainty of the determination of the filters.

[0066] In a 32nd aspect according to one or more of aspects from 16 to 31, the predefined blood flow intervals (ΔQb_1 - ΔQb_j) are comprised between about 0 ml/min and about 600 ml/min, for instance between about 10 ml/min and circa 580 ml/min.

[0067] In a 33rd aspect according to aspects 31 or 32, the predefined blood flow intervals (ΔQb_1 - ΔQb_j) are the following: $\Delta Qb_1=10$ -265 ml/min, $\Delta Qb_2=265$ -335 ml/min, $\Delta Qb_3=335$ -580 ml/min.

[0068] In a 34th aspect each filter combined to a predefined sampling frequency (Fs_1 - Fs_j) is defined as follows:

calculating the cutting frequency " ω_c " expressed in radians as $\omega_c = 2\pi \times Fc/Fs_j$;

expressing the pulse response which characterizes the low-pass filter according to the cutting frequency " ω_c " as:

$$\begin{aligned} h_p[n] &= \frac{1}{2\pi} \int_{-\omega_c}^{\omega_c} e^{j\omega n} d\omega \\ &= \frac{1}{2\pi j n} \left[e^{j\omega n} \right]_{-\omega_c}^{\omega_c} = \frac{1}{2\pi j n} (e^{j\omega_c n} - e^{-j\omega_c n}) \\ &= \frac{\sin \omega_c n}{\pi n}, \quad -\infty < n < \infty \end{aligned}$$

[0069] In a 35th aspect according to one or more of aspects from 16 to 34, the desired cutting frequency "Fc" is comprised between about 1 Hz and about 4Hz, for instance 2 Hz.

[0070] In a 36th aspect according to one or more of aspects from 16 to 35, the filters are applied to the signal "Ps" indicating the blood pressure in the extracorporeal blood circuit (2) to extract/isolate the pressure data deriving from the physiological pressure generators with the aim, for example, of monitoring the venous access (VNM), and of identifying the so-called venous needle dislodgement (VND).

Description of the drawings

[0071] Some drawings relating to aspects of the inven-

tion are provided by way of non-limiting example.

[0072] In particular:

- figure 1 schematically shows a blood treatment apparatus according to the invention;
- figure 2 shows a portion of the apparatus of figure 1 in a larger scale;
- figure 3 is a flow chart showing a control procedure according to an aspect of the invention that can be carried out by the control unit of an apparatus for example of the type shown in figure 1.

Detailed description

[0073] With reference to the accompanying drawings, 1 denotes an apparatus for extracorporeal blood treatment.

[0074] The apparatus 1 comprises an extracorporeal circuit 2 intended to extract blood to be processed from the cardiovascular system of a patient "P" and to return the treated blood to the patient.

[0075] In the following passages some possible examples of the general structure of the apparatus 1 are described. In particular, some configurations of the extracorporeal blood circuit 2, of any possible infusion lines in which a replacement fluid circulates, of the dialysis line, if any, in which a dialysis fluid circulates, and of the discharge line of the discharge fluid are described below.

[0076] With reference to figure 1, the apparatus 1 for extracorporeal blood treatment comprises at least a treatment unit 3, for example a hemofilter, a hemodiafilter, a plasma filter, a dialysis filter, a membrane oxygenator or another unit intended to process the blood removed from the patient, having at least a first chamber and at least a second chamber 4 and 5 separated from one another by a semipermeable membrane 6. A blood removal line 7 is connected by an inlet port 4a to the first chamber 4 and is predisposed, in operating positions of connection to the patient "P", to remove blood from a vascular access inserted, for example, in a fistula in the patient "P". A blood return line 8 connected with an outlet port 4b of the first chamber 4 is designed to receive the treated blood from the treatment unit 3 and to return the treated blood to a further vascular access connected with the fistula of the patient "P". Note that the configuration of the vascular access can be of any type: for example a catheter, a port implanted in the patient, a cannula, a needle etc..

[0077] As it can be seen in figure 1, the apparatus 1 comprises at least a first actuator, in the example a blood pump 9, operating at the blood removal line to promote movement of blood removed from the patient "P" from a first end 7a of the removal line 7 connected to the patient "P" towards the first chamber 4. The blood pump 9 is a rotary peristaltic pump, which is active, as shown in figures 1 and 2, on a respective section of tube 10 and able, when moved in a clockwise direction with reference to the figures, to move a blood flow along the removal line 7 towards the first chamber 4 (see the arrows indicating

the flow along the line 7).

[0078] It should be noted that for the purposes of the present description and the attached claims the terms "upstream" and "downstream" can be used with reference to relative positions assumed by components that are a part of or operate on the extracorporeal circuit 2. The terms are understood to mean in reference to a blood flow direction from the first end 7a of the removal line 7 connected to the patient "P" towards the first chamber 4 and thus towards the second end 8a of the return line 8 connected to the vascular access of the patient "P".

[0079] In the example of figure 1 the extracorporeal circuit 2 comprises at least an arterial expansion chamber 11 operating on the blood removal line 7 of the patient "P" and arranged upstream of the first chamber 4 and upstream of the blood pump 9. The arterial expansion chamber 11 receives blood directly from the patient "P" and accumulates a setting quantity remaining substantially constant during the whole treatment. The extracorporeal circuit comprises at least a venous expansion chamber 12 operating on the blood return line 8 to the patient "P", downstream of the first chamber 4 and upstream of the vascular access which returns the blood to the patient "P".

[0080] At least a pressure sensor 13 is configured to detect at least a parameter related to the fluid pressure present in the arterial expansion chamber 11 and a pressure sensor 14 is configured to detect at least a parameter related to the fluid pressure present in the venous expansion chamber 12. In general, the pressure sensors 13, 14 are configured to emit a respective signal corresponding to a measured value of the parameter, and send it to a control unit "CU" on each measurement carried out in successive time instants. Note that it is possible to carry out the detection of the pressure parameter even in close proximity to the arterial or venous expansion chamber 11, 12, for example via a transducer located in either the tube section between the arterial expansion chamber 11 and the blood pump 9 or in the tract of tube between the arterial expansion chamber 11 and the vascular access to the patient P, or via a transducer located either in the tract of tube between the venous expansion chamber 12 and the return vascular access to the patient "P" or in the tract of tube between the first chamber 3 and the venous expansion chamber 12.

[0081] In any case, in a possible adequate positioning of the pressure sensors 13, 14 they act directly in the corresponding arterial and venous expansion chamber 11, 12 at an upper portion thereof where normally (in use) a gas (air) is housed. It is worthy of note that the arterial and venous expansion chambers 11, 12 are in general configured in use and during the treatment to house a predetermined quantity of gas in an upper portion and a predetermined quantity of blood at a predetermined level in a lower portion thereof. Each of the arterial and venous expansion chambers 11, 12 exhibits an inlet for the blood in fluid connection, respectively, with a first part of the removal line 7 connected to the vascular access of the

patient "P" and with a portion of the return line downstream of the treatment unit 3. The chambers 11, 12 receive, through the inlet, blood to the chamber itself. In general, the inlets might be positioned at a base portion of the corresponding expansion chamber which is arranged, in use, downwards and is occupied by blood. In an embodiment the inlets can be in connection with a respective internal chamber of the arterial and venous expansion chamber 11, 12 which exhibits a release in the chamber at a predetermined height with respect to the base. Each of the arterial expansion and venous expansion chambers 11, 12 further comprises a respective outlet for the blood in fluid connection with the extracorporeal circuit 2 such as to let, in use, the blood flow out from the chambers. The outlets too are positioned at a base portion of the respective expansion chamber 11, 12 which is arranged, in use, downwards and is occupied by blood.

[0082] The portion of removal line 7 which connects the outlet of the arterial expansion chamber 11 to the first chamber 4 of the treatment unit 3 comprises the tract of tube 10 which is engaged by the peristaltic blood pump 9 such as to move, by squeezing the tract of tube 10, the blood in the extracorporeal circuit 2. The particular type of peristaltic pump 9 illustrated is provided with two squeezing bodies (lobes or rollers) 15 such as to act on the tract of tube 10 twice at each rotation of the blood pump 9.

[0083] Each of the expansion chambers 11, 12 also exhibits a ventilation opening 16, 17 configured to enable, in use, passage of gas from or towards the expansion chamber 11, 12 for example from or towards the external environment. The apparatus further comprises an actuator 18, 19 for each chamber 11, 12 operating on the ventilation opening 16, 17 (for example on a channel connected thereto) to selectively prevent or enable passage of gas. The ventilation opening 16, 17 is in particular positioned at an upper portion of the expansion chamber 11, 12 which is arranged, in use, upwards, and is occupied by gas. The actuator 18, 19 can be an air pump or also a simple clamp (or another obturator) commanded or not by the control unit "CU" to enable a gas vent in case of need.

[0084] In relation to the setting level of blood in the arterial and venous expansion chambers 11, 12, it should be noted that in general the level should be comprised in a range of heights between a minimum value and a maximum value (possibly and in general the minimum value and the maximum value of the venous chamber 12 are different from the maximum and minimum levels of the arterial expansion chamber 11). With the blood level values in the chamber within the above values, we can assume that the apparatus is working in safety conditions; below or above the minimum values, problems of various nature may arise (more fully explained in the following), especially during treatment.

[0085] Not least, it is noteworthy that at least one and in general both the arterial and venous expansion cham-

bers 11 and 12 exhibit a constant containing volume, i.e. the chamber is made of a rigid and substantially undeformable material.

[0086] The apparatus 1 further comprises a first flow check organ 20, operating on the removal line 7 upstream of the blood pump 9 and the arterial expansion chamber 11 and at least a second check organ 21 of the fluid operating on the blood return line 8 to the patient, downstream of the venous expansion chamber 12. The check organs 20, 21, for example each constituted by a respective clamp commanded by the control unit "CU", are arranged in proximity of the ends 7a, 8a of the respective lines 7, 8 connectable to the patient "P".

[0087] The apparatus 1 can also comprise an air bubble sensor 22 connected to the control unit "CU" and able to generate a signal which, if above a threshold, determines generation of a closure command of the check organ 21 and possibly a halting of the blood pump 9. The air bubble sensor 22 is in particular located on the blood return line 8 and still more in particular downstream of the venous expansion chamber 12 along the blood flow direction in the extracorporeal body 2.

[0088] The blood removal line 7, the arterial expansion chamber 11, the first chamber 4 of the treatment unit 3, the blood return line 8 to the patient "P" and the venous expansion chamber 12 are part of the extracorporeal blood circuit 2 which, during the use of the apparatus 1, circulates blood externally of the body of the treated patient "P".

[0089] The apparatus 1 further comprises at least a fluid drainage line 23 connected with an outlet port of the second chamber 5 to receive at least fluid filtered across the semipermeable membrane 6. The drainage line 23 receives the discharge fluid coming from the second chamber 5 of the unit 3, for example, comprising used dialysis liquid and/or liquid ultra-filtered through the membrane 6.

[0090] The drainage line 23 leads to a receiving element 24, for example consisting of a collecting bag or a discharge piping of the discharge fluid. One or more dialysate pumps 25 can operate on the drainage line 23. In the figures a single pump is shown by way of example, acting on the drainage line 23. Note that the structure of the drainage line 23 can also be different with respect to what is illustrated (as long as it is able to adequately remove the fluid exiting from the second chamber 5). For example, the drainage line 23 can comprise a single line as shown in the accompanying figures or a main discharge line and an ultrafiltration line which branches out from the main discharge line and which is provided with a respective pump (solution not illustrated).

[0091] In the example of figure 1 a dialysis line 26 is also present for supplying fresh dialysis fluid for treatment entering the second chamber 5. The presence of the dialysis line 26 is not strictly necessary inasmuch as, in the absence of the line 26, the apparatus 1 is however able to carry out treatments such as ultrafiltration, hemofiltration or plasma filtration.

[0092] In a case in which the dialysis line 26 is present, a fluid check organ 27 can be used to selectively enable or prevent fluid passage through the dialysis line 26, depending on whether or not a purification by diffusive effect internally of the treatment unit 3 is planned. The dialysis line 26, if present, is in general provided with a dialysis pump 28 and is able to receive a fresh fluid from a module 29, for example a bag or an on-line preparation section of dialysis liquid, and send the fluid in inlet to the second chamber 5. Lastly, the apparatus 1 can comprise one or more replacement fluid infusion lines: for example an infusion line 30 can be provided which is connected to the removal line 7 and/or an infusion line 31 connected to the blood return line 8. The pre and/or post-infusion lines 30, 31 can be supplied by appropriate bags or directly by fresh dialysis fluid prepared on-line. The lines are only schematically represented in the accompanying figures.

[0093] The apparatus 1 comprises a position sensor 32 associated to the peristaltic pump 9 and configured to enable determining a plurality of reference positions "pr₁-pr_n" which the peristaltic pump 9 assumes in its cyclic motion.

[0094] The illustrated position sensor 32 is a phonic wheel or encoder which comprises a rotor 33 and a pick-up 34 or inductive proximity sensor. The rotor 33 of the phonic wheel 32 is solidly constrained to the lobe or roller rotor 15 of the peristaltic pump 9 such as to rotate together with the pump rotor 9. In the accompanying figures, this constraint is schematically illustrated by means of a shaft 35 connecting the two rotors 33, 15. The proximity sensor 34 is mounted fixed on the apparatus 1 and faces towards the rotor 33. The rotor 33 of the phonic wheel 32 exhibits a plurality of reference signs "r₁-r_n" (teeth, reliefs, notches) arranged along a circumferential pathway and facing towards the proximity sensor 34. The proximity sensor 34 detects the flow variation of the magnetic field due to the passage of the reference signs "r₁-r_n". The flow variation generates an alternating pulsating induced current and each of the reference signs "r₁-r_n" corresponds to a respective pulse.

[0095] The control unit "CU" may comprise one or more digital units, for example of the microprocessor type, or one or more analog units, or an appropriate combination of digital and analog units. As illustrated in the example of figure 1, the control unit "CU" is connected with the blood peristaltic pump 9 and/or with the dialysate pump 25 and/or with the dialysis pump 28, as well as with pressure sensors 13 and 14 of the arterial and venous expansion chambers 11, 12 and possibly, if present, with auxiliary pressure sensors. The control unit "CU" is further operatively connected with the phonic wheel 32, in particular with the proximity sensor 34. Further, the control unit can be connected to the fluid check organs 20, 21 and, if present, 27. The control unit "CU" is also in communication with the device for detecting bubbles 22, with the module 29 and possibly with the actuators 17 and 18 on the ventilation lines 16 and 17.

[0096] The control unit "CU" is configured or pro-

grammed to perform the procedures described in the following. In a case in which the control unit "CU" is of the programmable type, this unit is connected to a data support for storing instructions which, when performed by the control unit, determine the execution of the procedures which will be described in the following. The data support can comprise a mass memory, for example optical or magnetic, a reprogrammable memory (EPROM, FLASH) or a memory of another type. In general, before start of treatment, the apparatus 1 is subjected to a priming procedure controlled by the control unit "CU". In particular, before the treatment a physiological solution is injected into the extracorporeal circuit to wash it and remove any air and residual particles. At the end of this procedure, a setting level of the physiological solution at working pressure is established in the arterial 11 and venous expansion chambers. Once the patient "P" is connected to the apparatus 1 by means of the vascular accesses, the control unit 21 is configured to move at least the blood pump 9 at the start of a treatment in order to create, in the expansion chambers 11, 12, a blood setting level in the lower portion and to confine a complementary quantity of gas in the upper portion, the treatment at this point proceeds for the necessary duration with the aim of appropriately treating the blood removed from the patient "P".

[0097] During the whole treatment the blood level in the arterial and venous expansion chamber 11, 12, is continually modified (even if by small values) at least following the fact that the control unit "CU" moves the blood pump 9 in order to generate a variable blood flow comprising a constant flow component at a desired blood flow value and a variable flow component with a substantially nil mean value. This is in particular due to the fact that the blood pump is peristaltic and thus produces a blood flow in the circuit that is not constant, but linked to successive squeezing actions on the tract of tube 10 by the roller/s associated to the rotor of the pump 9.

[0098] During the treatment it is necessary to monitor and analyse the behaviour of the patient's physiological pressure generators such as the heart and/or the respiratory system. For this purpose, the control unit "CU" is arranged to receive from the pressure sensors 13, 14 located in the respective chambers 11, 12 signals "Ps" indicating the blood pressure in the extracorporeal blood circuit 2. These signals are sampled with a variable sampling frequency that is a function of the rotation velocity of the peristaltic pump 9.

[0099] A basic principle implemented by the control unit "CU" and described in the following in detail is detecting/sampling the signal "Ps" indicating the blood pressure from each of the sensors 13, 14 when the peristaltic pump 9 is in a plurality of predefined positions "pp₁-pp_y". In other words, the instants of detection of the pressure signal coincide with the passage of the peristaltic blood pump 9 through a plurality of predefined positions "pp₁-pp_y" during the cyclic motion thereof. Therefore the sampling of the pressure signal (or the signals) "Ps" is

carried out with a frequency that is not constant but depends on the velocity of the peristaltic blood pump 9.

[0100] To this end, the control unit "CU" receives from the proximity sensor 34 a succession of "n" reference signals "sr₁-sr_n" indicating reference positions "pr₁-pr_n" of the peristaltic pump 9. Each of these signals "sr₁-sr_n" is generated by one of the reference signals "r₁-r_n" located on the rotor 33 of the phonic wheel 32 which rotates, together with the pump 9, in front of the proximity sensor 34. In particular, the signal generated by the proximity sensor 34 is a square wave which defines the angular position of the peristaltic pump 9. Each period of the square wave signal corresponds to one of the reference signals "sr₁-sr_n" and is equivalent to a rotation of a predetermined number of degrees of the pump 9 axis. For example, the phonic wheel 32 generates a signal with nine hundred and sixty periods per each rotation of the pump 9.

[0101] This signal is used as an input for a first counter, which increases, for example, at each rising edge of the signal. A second counter increases at each predetermined time interval (time-based), for example every 2 ms.

[0102] The value of the first counter, supplied by the signal of the phonic wheel 32, enables establishing when the peristaltic blood pump 9 has performed a 360° rotation (after nine hundred and sixty periods of the signal). The value of the second counter is read at each complete rotation of the peristaltic blood pump 9, from which the period of rotation of the peristaltic pump 9 is calculated and, consequently, the rotation velocity "ω" thereof in [cycles/s].

[0103] The volume of blood "Sv" moved by the peristaltic pump 9 in a complete cycle in [ml/cycle] is a known datum which depends on the peristaltic pump 9 used.

[0104] The instant flow "Qb" of the peristaltic pump 9 in [ml/min] is proportional to the rotation velocity "ω" of the pump 9 or to the frequency "Fr" of the reference signals "sr₁-sr_n" according to the following relations:

$$Qb = \omega \times Sv \times 60 = Fr \times (Sv \times 60)/n$$

[0105] By way of example, if Sv = 7.65 ml/cycle and ω = 0.6 cycles/s (which corresponds to an Fr = 576 Hz if n = 960) then Qb = 275 ml/min.

[0106] The control unit "CU" further receives, from each of the pressure sensors 13, 14, a respective pressure signal "Ps" and is programmed to detect/sample the signal "Ps" each time the peristaltic pump 9 is in a plurality of predefined positions "pp₁-pp_y". In other words, the instants of detection of the pressure signal "Ps" coincide with the passage of the peristaltic blood pump 9 through a plurality of predefined positions "pp₁-pp_y" during the cyclic motion thereof. Thus, the sampling of the pressure signal (or signals) is carried out at a frequency that is not constant but depends on the velocity of the peristaltic blood pump 9.

[0107] The predefined positions "pp₁-pp_y" can match wholly or in part with the reference positions "pr₁-pr_n". In other words, the reference signals "sr₁-sr_n" generated in a pump-cycle "n" may all be used to command detection of the signal "Ps" indicating the pressure or one only every "m". If all of them are used, then the reference positions are predefined positions, otherwise only a part of the reference positions are predefined positions. The number "y" of the predefined positions is the relation "n/m".

[0108] For example, one each eight reference signals "sr₁-sr_n" is used to command detection of the signal "Ps" indicating the pressure, so that:

$$n=960$$

$$m=8$$

$$y=120$$

[0109] The sampling frequency "Fs" of the signal "Ps" indicating the pressure is given by the relation $Fs = \omega \times y = Fr \times y/n = Fr/m$. If m = 1, the sampling frequency "Fs" of the signal "Ps" indicating the pressure matches with the frequency "Fr" of the reference signal "sr₁-sr_n". In the example in which m = 8, the sampling frequency "Fs" of the signal "Ps" is (with ω = 0.6 cycle/s) equal to 72 Hz.

[0110] A further base principle implemented by the control unit "CU" and described in the following in detail is to dimension the filters used for example in order to monitor and analyse the behaviour of the physiological pressure generators of the patient, such as the heart and/or the respiratory system, on the basis of a limited number of predetermined sampling frequencies.

[0111] The control unit "CU" is programmed to contain a plurality of fields "Δω₁-Δω_j", "ΔFr₁-ΔFr_j" indicating predefined blood flow intervals "ΔQb₁-ΔQb_j". In an aspect the predefined intervals of the blood flow "ΔQb₁-ΔQb_j" are limited in number, for instance three or four. For instance, the blood flow intervals are three and are as follows: ΔQb₁ = 10-265 ml/min; ΔQb₂ = 265-335 ml/min; ΔQb₃ = 335-580 ml/min. To these intervals correspond (from relations $Qb = \omega \times Sv \times 60 = Fr \times (Sv \times 60)/n$) a same number of cyclic velocity fields (Δω₁ = 0.022 - 0.577 cycles/s; Δω₂ = 0.577 - 0.73 cycles/s; Δω₃ = 0.73 - 1.263 cycles/s) and of reference signal frequencies (ΔFr₁ = 20.9 - 554.2 Hz; ΔFr₂ = 554.2 - 700.6 Hz; ΔFr₃ = 700.6 - 1213.1 Hz). If m = 1, the frequency fields of the reference signals (ΔFr₁; ΔFr₂; ΔFr₃) match with sampling frequency fields (ΔFs₁; ΔFs₂; ΔFs₃) of the signal "Ps" indicating the pressure. In the case of the example in which m = 8, the following frequency sampling fields correspond to the frequency fields of the reference signals: ΔFs₁ = 2.61 - 69.3 Hz; ΔFs₂ = 69.3 - 87.6 Hz; ΔFs₃ = 87.6 - 151.6 Hz.

[0112] The control unit "CU" is programmed to contain, for each of the fields "Δω₁-Δω_j", "ΔFr₁-ΔFr_j" indicating the blood flow intervals "ΔQb₁-ΔQb_j" a predefined sampling frequency value "Fs_k" of the signal "Ps" indicating the pressure. The predefined sampling frequency "Fs_k" for

instance corresponds to a reference value "Qb_k", for instance to the median value, of the respective blood flow interval "ΔQb_k".

[0113] In the illustrated example, to the first blood flow interval "ΔQb₁" corresponds a first predefined sampling frequency Fs₁ = 55 Hz (obtained considering a reference flow "Qb₁" of 210 ml/min); to the second blood flow interval "ΔQb₂" corresponds a second predefined sampling frequency Fs₂ = 79 Hz (obtained considering a reference flow "Qb₂" of 300 ml/min which is the median value of the respective interval); to the third blood flow interval "ΔQb₃" corresponds a third predefined sampling frequency Fs₃ = 97 Hz (obtained considering a reference flow "Qb₃" of 370 ml/min).

[0114] The control unit "CU" compares the instant flow "Qb" of the peristaltic pump 9 with the blood flow intervals "ΔQb₁-ΔQb_j" and verifies in which of the intervals the instant flow "Qb" falls. Actually, to perform this flow comparison, the control unit "CU" compares the instant rotation velocity "ω" of the pump 9 (or the instant frequency "Fr" of the reference signals "sr₁-sr_n") with the respective fields "Δω₁-Δω_j" (or ΔFr₁-ΔFr_j) and verifies in which of the respective fields "Δω₁-Δω_j" (o ΔFr₁-ΔFr_j) falls.

[0115] The control unit "CU" uses the predefined sampling frequency "Fs_k" associated to the cyclic velocity field "Δω_k" (among the cyclic velocity fields "Δω₁-Δω_j") in which the instant cyclic velocity "ω" falls that corresponds to the instant blood flow "Qb" (or associated to the field "ΔFr_k" among the frequency fields "ΔFr₁-ΔFr_j" of the reference signals "sr₁-sr_n" in which the frequency "Fr" of the reference signals detected corresponding to the instant blood flow "Qb" falls) in order to dimension the low-pass filter (Anti-Aliasing and/or Noise Suppressor) which is to be used given a desired cutting frequency "Fc".

[0116] The Anti-Aliasing and Noise Suppressor filters are applied for instance to the signal "Ps" indicating the blood pressure in the extracorporeal blood circuit 2 in order to extract/isolate the pressure data deriving from the physiological pressure generators with the aim, for example, of monitoring the venous access (VNM) and identifying the dislodgement of the venous needle (VND).

[0117] Both the Anti-Aliasing and the Noise Suppressor filters are for instance fourth-order Infinite Impulse Response (IIR) passbands.

[0118] In the illustrated example, given a desired cutting frequency "Fc" of 2 Hz, the cutting frequencies "ω_c" expressed in radians of three lowpass filters each combined with one of the three predefined sampling frequencies "Fs₁, Fs₂, Fs₃" are:

$$1. \omega_{c1} = Fc/Fs_1 = 0,226 \text{ rad}$$

$$1. \omega_{c2} = Fc/Fs_2 = 0,159 \text{ rad}$$

$$2. \omega_{c3} = Fc/Fs_3 = 0,129 \text{ rad}$$

[0119] The pulsation response characterizing each lowpass filter according to the respective cutting frequency "ω_{ck}" is expressed as:

$$\begin{aligned} h_{lp}[n] &= \frac{1}{2\pi} \int_{-\omega_c}^{\omega_c} e^{j\omega n} d\omega \\ &= \frac{1}{2\pi j n} \left[e^{j\omega n} \right]_{-\omega_c}^{\omega_c} = \frac{1}{2\pi j n} (e^{j\omega_c n} - e^{-j\omega_c n}) \\ &= \frac{\sin \omega_c n}{\pi n}, \quad -\infty < n < \infty \end{aligned}$$

[0120] To sum up, the type of filter is selected among a discrete and small number of filters, each associated to a flow interval "ΔQb_k" of the peristaltic pump 9 and dimensioned on the basis of the respective sampling frequency "Fs_k" so as to have a desired cutting frequency "Fc". According to the measured instant value of the blood flow "Qb", the control unit "CU" uses one of the filters and changes the filter when the instant measured value of the blood flow "Qb" during the treatment falls in a different interval. Obviously the described methodology is usable in combination with any type of pressure detecting sensor located in the most appropriate points of the extracorporeal blood circuit 2.

[0121] While the invention has been described in relation to what is at present considered the preferred and most modern embodiment, the invention is not limited to the described embodiment but, on the contrary, is intended to cover various modifications and equivalent combinations included in the appended claims.

Claims

1. An apparatus for extracorporeal blood treatment comprising:

- at least a treatment unit (3) having at least a first chamber (4) and at least a second chamber (5) separated from one another by a semi-permeable membrane (6);
- at least a blood removal line (7) connected to an inlet port (4a) of the first chamber (4) and predisposed to remove blood from a patient (P);
- at least a blood return line (8) connected to an outlet port (4b) from the first chamber (4) and predisposed to return treated blood to the patient (P), wherein the blood removal line (7), the blood return line (8) and the first chamber (4) are part of an extracorporeal blood circuit (2);
- at least a peristaltic pump (9) operating at the

extracorporeal blood circuit (2) for moving the blood in the circuit (2);

- at least a pressure sensor (13, 14) associated to the extracorporeal blood circuit (2) and configured to enable determination of pressure values in said extracorporeal blood circuit (2);
 - at least a fluid drainage line (23) connected to an outlet port of said second chamber (5);
 - a control unit (CU) connected to said at least a pressure sensor (13, 14) and to the peristaltic pump (9) and configured to:

- move the peristaltic pump (9) with a cyclic motion to generate a blood flow;
 - receive from said at least a pressure sensor (13, 14) a signal (Ps) indicating the pressure of the blood in the extracorporeal blood circuit (2);
 - sample, for each cycle of the peristaltic pump (9), the signal (Ps) indicating the blood pressure with a frequency in the time domain depending on the velocity (ω) of the peristaltic pump (9);

characterized in that the control unit (CU) is further configured to:

- receive a signal (ω , Fr) indicating the instant blood flow (Qb) in the peristaltic pump (9);
 - compare the signal (ω , Fr) with a plurality of fields ($\Delta\omega_1-\Delta\omega_j$, $\Delta Fr_1-\Delta Fr_j$) indicating predefined intervals of blood flow ($\Delta Qb_1-\Delta Qb_j$) each combined with a respective predefined sampling frequency (Fs_1-Fs_j) of the signal (Ps) indicating the blood pressure;
 - identify the field ($\Delta\omega_k$, ΔFs_k) in the plurality of fields ($\Delta\omega_1-\Delta\omega_j$, $\Delta Fr_1-\Delta Fr_j$) to which the signal belongs (ω , Fr);
 - identify the respective predefined sampling frequency (Fs_k);
 - dimension a filter to be used on the basis of the predefined sampling frequency (Fs_k) and at a desired cutting frequency (Fc);
 - apply the filter to the sampled signal (Ps) indicative of the blood pressure.

2. The apparatus of claim 1, wherein the signal (Ps) indicating the blood pressure is sampled when the peristaltic pump (9) is in a plurality of predefined positions (pp_1-pp_y).
3. The apparatus of claim 1 or 2, comprising at least a position sensor (32) associated to the peristaltic pump (9) and configured to enable determination of positions of the peristaltic pump (9); wherein the control unit (CU) is configured to carry out the sampling step which comprises:

- receiving from the position sensor (32) a succession of "n" reference signals (sr_1-sr_n) indicating reference positions (pr_1-pr_n) of the peristaltic pump (9);

- sampling the signal (Ps) indicating the blood pressure every "m" reference signals (sr_1-sr_n), where "m" is equal to or greater than one and less than or equal to n.

4. The apparatus of claim 3, wherein "n" is greater than or equal to fifty.
5. The apparatus of claim 3 or 4, wherein "m" is smaller than ten.
6. The apparatus of claim 3, 4 or 5, wherein the position sensor (32) comprises a phonic wheel (33) coupled to the peristaltic pump (9).
7. The apparatus of one of the preceding claims, wherein the signal (ω , Fr) indicating the instant blood flow (Qb) is a cyclic velocity (ω) of the peristaltic pump (9).
8. The apparatus of the preceding claim, wherein the cyclic velocity (ω) is an average calculated on each cycle of the peristaltic pump (9).
9. The apparatus of one of the preceding claims wherein the fields ($\Delta\omega_1-\Delta\omega_j$, $\Delta Fr_1-\Delta Fr_j$) indicating the predefined blood flow ($\Delta Qb_1-\Delta Qb_j$) are cyclic velocity fields ($\Delta\omega_1-\Delta\omega_j$).
10. The apparatus of one of the preceding claims wherein the signal (ω , Fr) indicating the instant blood flow (Qb) is a frequency (Fr) of reference signals (sr_1-sr_n) indicating positions of the peristaltic pump (9).
11. The apparatus of claim 10, wherein the frequency (Fr) of the reference signals (sr_1-sr_n) is an average calculated on each cycle of the peristaltic pump (9).
12. The apparatus of one of the preceding claims, wherein the fields ($\Delta\omega_1-\Delta\omega_j$, $\Delta Fr_1-\Delta Fr_j$) indicating the predefined blood flow intervals ($\Delta Qb_1-\Delta Qb_j$) are frequency fields ($\Delta Fr_1-\Delta Fr_j$) of reference signals (sr_1-sr_n) indicating positions of the peristaltic pump.
13. The apparatus of one of claims 10, 11 or 12, wherein the frequency (Fr) of the reference signals (sr_1-sr_n) corresponds to the sampling frequency (Fs) of the signal (Ps) indicating the blood pressure or to a multiple of the sampling frequency (Fs).
14. The apparatus of one of the preceding claims, wherein each predefined sampling frequency (Fs_1-Fs_j) corresponds to a predefined value (Qb_1-Qb_j) of the respective predefined interval of

blood flow ($\Delta Qb_1-\Delta Qb_j$).

15. The apparatus of one of the preceding claims, wherein the number (j) of predefined intervals of blood flow ($\Delta Qb_1-\Delta Qb_j$) is comprised between two and five.

Patentansprüche

1. Vorrichtung zur extrakorporalen Blutbehandlung, umfassend:

- mindestens eine Behandlungseinheit (3), die mindestens eine erste Kammer (4) und mindestens eine zweite Kammer (5) aufweist, die durch eine semipermeable Membran (6) getrennt sind;
- mindestens eine Blutentnahmeleitung (7), verbunden mit einem Eingangsanschluss (4a) der ersten Kammer (4) und prädisponiert, um Blut von einem Patienten (P) zu entnehmen;
- mindestens eine Blutrückgabeleitung (8), verbunden mit einem Ausgangsanschluss (4b) der ersten Kammer (4) und prädisponiert, um behandeltes Blut an den Patienten (P) zurückzugeben, wobei die Blutentnahmeleitung (7), die Blutrückgabeleitung (8) und die erste Kammer (4) Teil eines extrakorporalen Blutkreislaufs (2) sind;
- mindestens eine Peristaltik-Pumpe (9), die am extrakorporalen Blutkreislauf (2) betrieben wird, um das Blut im Kreislauf (2) zu bewegen;
- mindestens einen Drucksensor (13, 14), angeschlossen an den extrakorporalen Blutkreislauf (2) und konfiguriert, um eine Bestimmung von Druckwerten im extrakorporalen Blutkreislauf (2) zu ermöglichen;
- mindestens eine Fluidablaufleitung (23), verbunden mit einem Ausgangsanschluss der zweiten Kammer (5);
- eine Steuereinheit (CU), verbunden mit dem mindestens einen Drucksensor (13, 14) und mit der Peristaltik-Pumpe (9) und konfiguriert, um:

- die Peristaltik-Pumpe (9) mit einer zyklischen Bewegung zu bewegen, um einen Blutfluss zu generieren;
- ein Signal (Ps) vom mindestens einen Drucksensor (13, 14) zu empfangen, das den Druck des Blutes im extrakorporalen Blutkreislauf (2) angibt;
- das Signal (Ps) für jeden Zyklus der Peristaltik-Pumpe (9) abzutasten, das den Blutdruck mit einer Frequenz im Zeitbereich abhängig von der Geschwindigkeit (ω) der Peristaltik-Pumpe (9);

gekennzeichnet dadurch, dass die Steuereinheit

(CU) weiter konfiguriert ist, um:

- ein Signal (ω , Fr) zu empfangen, das den momentanen Blutfluss (Qb) in der Peristaltik-Pumpe (9) angibt;
- das Signal (ω , Fr) mit einer Mehrzahl von Feldern ($\Delta\omega_1-\Delta\omega_j$, $\Delta Fr_1-\Delta Fr_j$) zu vergleichen, die vordefinierte Intervalle des Blutflusses ($\Delta Qb_1-\Delta Qb_j$) angeben, jedes kombiniert mit einer jeweiligen vordefinierten Abtastfrequenz ($\Delta Fs_1-\Delta Fs_j$) des Signals (Ps), das den Blutdruck angibt;
- das Feld ($\Delta\omega_k$, ΔFs_k) in der Mehrzahl von Feldern ($\Delta\omega_1-\Delta\omega_j$, $\Delta Fr_1-\Delta Fr_j$) zu identifizieren, zu dem das Signal gehört (ω , Fr);
- die jeweilige vordefinierte Abtastfrequenz (Fs_k) zu identifizieren;
- einen zu verwendenden Filter zu dimensionieren, auf Basis der vordefinierten Abtastfrequenz (Fs_k) und bei einer gewünschten Grenzfrequenz (Fc);
- den Filter auf das abgetastete Signal (Ps), das den Blutdruck angibt, anzuwenden.

2. Vorrichtung nach Anspruch 1, wobei das Signal (Ps), das den Blutdruck angibt, abgetastet wird, wenn die Peristaltik-Pumpe (9) sich in einer Mehrzahl von vordefinierten Positionen (pp_1-pp_y) befindet.

3. Vorrichtung nach Anspruch 1 oder 2, umfassend mindestens einen Positionssensor (32), der an der Peristaltik-Pumpe (9) angeschlossen und konfiguriert ist, eine Bestimmung von Positionen der Peristaltik-Pumpe (9) zu ermöglichen; wobei die Steuereinheit (CU) konfiguriert ist, um den Abtastschritt auszuführen, welcher umfasst:

- Empfangen einer Abfolge von "n" Bezugssignalen (sr_1-sr_n) vom Positionssensor (32), die Bezugspositionen (pr_1-pr_n) der Peristaltik-Pumpe (9) angeben;
- Abtasten des Signals (Ps), das den Blutdruck alle "m" Bezugssignale (sr_1-sr_n) angibt, wobei "m" gleich oder größer als eins und kleiner als oder gleich n ist.

4. Vorrichtung nach Anspruch 3, wobei "n" größer als oder gleich fünfzig ist.

5. Vorrichtung nach Anspruch 3 oder 4, wobei "m" kleiner als zehn ist.

6. Vorrichtung nach Anspruch 3, 4, oder 5, wobei der Positionssensor (32) einen Impulsring (33) umfasst, der an die Peristaltik-Pumpe (9) gekoppelt ist.

7. Vorrichtung nach einem der vorhergehenden Ansprüche, wobei das Signal (ω , Fr), das den momentanen Blutfluss (Qb) angibt, eine zyklische Ge-

schwindigkeit (ω) der Peristaltik-Pumpe (9) ist.

8. Vorrichtung nach dem vorhergehenden Anspruch, wobei die zyklische Geschwindigkeit (ω) ein Durchschnitt ist, der zu jedem Zyklus der Peristaltik-Pumpe (9) berechnet wird. 5
9. Vorrichtung nach einem der vorhergehenden Ansprüche, wobei die Felder ($\Delta\omega_1-\Delta\omega_j$, $\Delta Fr_1-\Delta Fr_j$), die den Blutfluss ($\Delta Qb_1-\Delta Qb_j$) angeben, zyklische Geschwindigkeitsfelder ($\Delta\omega_1-\Delta\omega_j$) sind. 10
10. Vorrichtung nach einem der vorhergehenden Ansprüche, wobei das Signal (ω , Fr), das den momentanen Blutfluss (Qb) angibt, eine Frequenz (Fr) von Bezugssignalen (sr_1-sr_n) ist, die Positionen der Peristaltik-Pumpe (9) angeben. 15
11. Vorrichtung nach Anspruch 10, wobei die Frequenz (Fr) der Bezugssignale (sr_1-sr_n) ein Durchschnitt ist, der zu jedem Zyklus der Peristaltik-Pumpe (9) berechnet wird. 20
12. Vorrichtung nach einem der vorhergehenden Ansprüche, wobei die Felder ($\Delta\omega_1-\Delta\omega_j$, $\Delta Fr_1-\Delta Fr_j$), die die vordefinierten Blutflussintervalle ($\Delta Qb_1-\Delta Qb_j$) angeben, Frequenzfelder ($\Delta Fr_1-\Delta Fr_j$) von Bezugssignalen (sr_1-sr_n) sind, die Positionen der Peristaltik-Pumpe angeben. 25
13. Vorrichtung nach einem der Ansprüche 10, 11, oder 12, wobei die Frequenz (Fr) der Bezugssignale (sr_1-sr_n) der Abtastfrequenz (F_s) des Signals (Ps) entspricht, das den Blutdruck angibt, oder einem Vielfachen der Abtastfrequenz (F_s). 30
14. Vorrichtung nach einem der vorhergehenden Ansprüche, wobei jede vordefinierte Abtastfrequenz ($F_{s_1}-F_{s_j}$) einem vordefinierten Wert (Qb_1-Qb_j) des jeweiligen vordefinierten Blutflussintervalls ($\Delta Qb_1-\Delta Qb_j$) entspricht. 35
15. Vorrichtung nach einem der vorhergehenden Ansprüche, wobei die Zahl (j) der vordefinierten Blutflussintervalle ($\Delta Qb_1-\Delta Qb_j$) zwischen zwei und fünf umfasst ist. 40

Revendications

1. Appareil pour le traitement extracorporel du sang comprenant: 50
- au moins une unité de traitement (3) ayant au moins un premier compartiment (4) et au moins un deuxième compartiment (5) séparés l'un de l'autre par une membrane semi-perméable (6);
 - au moins un conduit de prélèvement du sang

(7) relié à une porte d'entrée (4a) du premier compartiment (4) et apte à prélever le sang d'un patient (P);

- au moins un conduit de restitution du sang (8) relié à une porte de sortie (4b) du premier compartiment (4) et apte à restituer le sang traité au patient (P), où le conduit de prélèvement du sang (7), le conduit de restitution du sang (8) et le premier compartiment (4) font partie d'un circuit extracorporel du sang (2);

- au moins une pompe péristaltique (9) opérant sur le circuit extracorporel du sang (2) pour déplacer le sang dans le circuit (2);

- au moins un capteur de pression (13, 14) associé au circuit extracorporel du sang (2) et configuré pour permettre la détermination des valeurs de pression dans ledit circuit extracorporel du sang (2);

- au moins un conduit de décharge de fluide (23) relié à une porte de sortie dudit deuxième compartiment (5);

- une unité de commande (CU) reliée audit au moins un capteur de pression (13, 14) et à la pompe péristaltique (9) et configurée pour:

- déplacer la pompe péristaltique (9) avec un mouvement cyclique pour générer un flux du sang;

- recevoir dudit au moins un capteur de pression (13, 14) un signal (Ps) indiquant la pression du sang dans le circuit extracorporel du sang (2);

- échantillonner pour chaque cycle de la pompe péristaltique (9) le signal (Ps) indiquant la pression du sang avec une fréquence dans le domaine du temps en fonction de la vitesse (ω) de la pompe péristaltique (9);

caractérisé en ce que l'unité de commande (CU) est configurée en outre pour:

- recevoir un signal (ω , Fr) indiquant le flux du sang instantané (Qb) dans la pompe péristaltique (9);

- comparer le signal (ω , Fr) avec une pluralité de champs ($\Delta\omega_1-\Delta\omega_j$, $\Delta Fr_1-\Delta Fr_j$) indiquant des intervalles prédéfinis du flux du sang ($\Delta Qb_1-\Delta Qb_j$) chacun combiné avec une fréquence d'échantillonnage prédéfinie respective ($F_{s_1}-F_{s_j}$) du signal (Ps) indiquant la pression du sang;

- identifier le champ ($\Delta\omega_k$, ΔFr_k) dans la pluralité de champs ($\Delta\omega_1-\Delta\omega_j$, $\Delta Fr_1-\Delta Fr_j$) à laquelle appartient le signal (ω , Fr);

- identifier la fréquence d'échantillonnage prédéfinie respective (F_{s_k});

- dimensionner un filtre à employer sur la base

- de la fréquence d'échantillonnage prédéfinie (F_{s_k}) et à une fréquence de coupure désirée (F_c);
- appliquer le filtre au signal échantillonné (P_s) indiquant la pression du sang. 5
2. Appareil selon la revendication 1, où le signal (P_s) indiquant la pression du sang est échantillonné lorsque la pompe péristaltique (9) est dans une pluralité de positions prédéfinies (pp_1 - pp_y). 10
3. Appareil selon la revendication 1 ou 2, comprenant au moins un capteur de position (32) associé à la pompe péristaltique (9) et configuré pour permettre la détermination des positions de la pompe péristaltique (9);
où l'unité de commande (CU) est configuré pour exécuter l'étape d'échantillonnage comprenant:
- recevoir du capteur de position (32) une séquence de "n" signaux de référence (sr_1 - sr_n) indiquant des positions de référence (pr_1 - pr_n) de la pompe péristaltique (9);
- échantillonner le signal (P_s) indiquant la pression du sang chaque "m" signaux de référence (sr_1 - sr_n), où "m" est égal ou supérieur à un et inférieur ou égal à n. 20 25
4. Appareil selon la revendication 3, où "n" est supérieur ou égal à cinquante. 30
5. Appareil selon la revendication 3 ou 4, où "m" est inférieur à dix.
6. Appareil selon la revendication 3, 4 ou 5, où le capteur de position (32) comprend une roue phonique (33) couplée à la pompe péristaltique (9). 35
7. Appareil selon l'une des revendications précédentes, où le signal (ω , Fr) indiquant le flux du sang instantané (Q_b) est une vitesse cyclique (ω) de la pompe péristaltique (9). 40
8. Appareil selon la revendication précédente, où la vitesse cyclique (ω) est une moyenne calculée sur chaque cycle de la pompe péristaltique (9). 45
9. Appareil selon l'une des revendications précédentes, où les champs ($\Delta\omega_1$ - $\Delta\omega_j$, ΔFr_1 - ΔFr_j) indiquant le flux du sang prédéfini (ΔQ_{b_1} - ΔQ_{b_j}) sont des champs de vitesse cyclique ($\Delta\omega_1$ - $\Delta\omega_j$). 50
10. Appareil selon l'une des revendications précédentes, où le signal (ω , Fr) indiquant le flux du sang instantané (Q_b) est une fréquence (Fr) des signaux de référence (sr_1 - sr_n) indiquant les positions de la pompe péristaltique (9). 55
11. Appareil selon la revendication 10, où la fréquence (Fr) des signaux de références (sr_1 - sr_n) est une moyenne calculée sur chaque cycle de la pompe péristaltique (9).
12. Appareil selon l'une des revendications précédentes, où les champs ($\Delta\omega_1$ - $\Delta\omega_j$, ΔFr_1 - ΔFr_j) indiquant les intervalles prédéfinis du flux du sang (ΔQ_{b_1} - ΔQ_{b_j}) sont des champs de fréquence (ΔFr_1 - ΔFr_j) des signaux de références (sr_1 - sr_n) indiquant les positions de la pompe péristaltique.
13. Appareil selon l'une des revendications 10, 11 ou 12, où la fréquence (Fr) des signaux de référence (sr_1 - sr_n) correspond à la fréquence d'échantillonnage (F_s) du signal (P_s) indiquant la pression du sang ou à un multiple de la fréquence d'échantillonnage (F_s).
14. Appareil selon l'une des revendications précédentes, où chaque fréquence d'échantillonnage prédéfinie (F_{s_1} - F_{s_j}) correspond à une valeur prédéfinie (Q_{b_1} - Q_{b_j}) de l'intervalle prédéfini respectif du flux du sang (ΔQ_{b_1} - ΔQ_{b_j}).
15. Appareil selon l'une des revendications précédentes, où le nombre (j) d'intervalles prédéfinis du flux du sang (ΔQ_{b_1} - ΔQ_{b_j}) est compris entre deux et cinq.

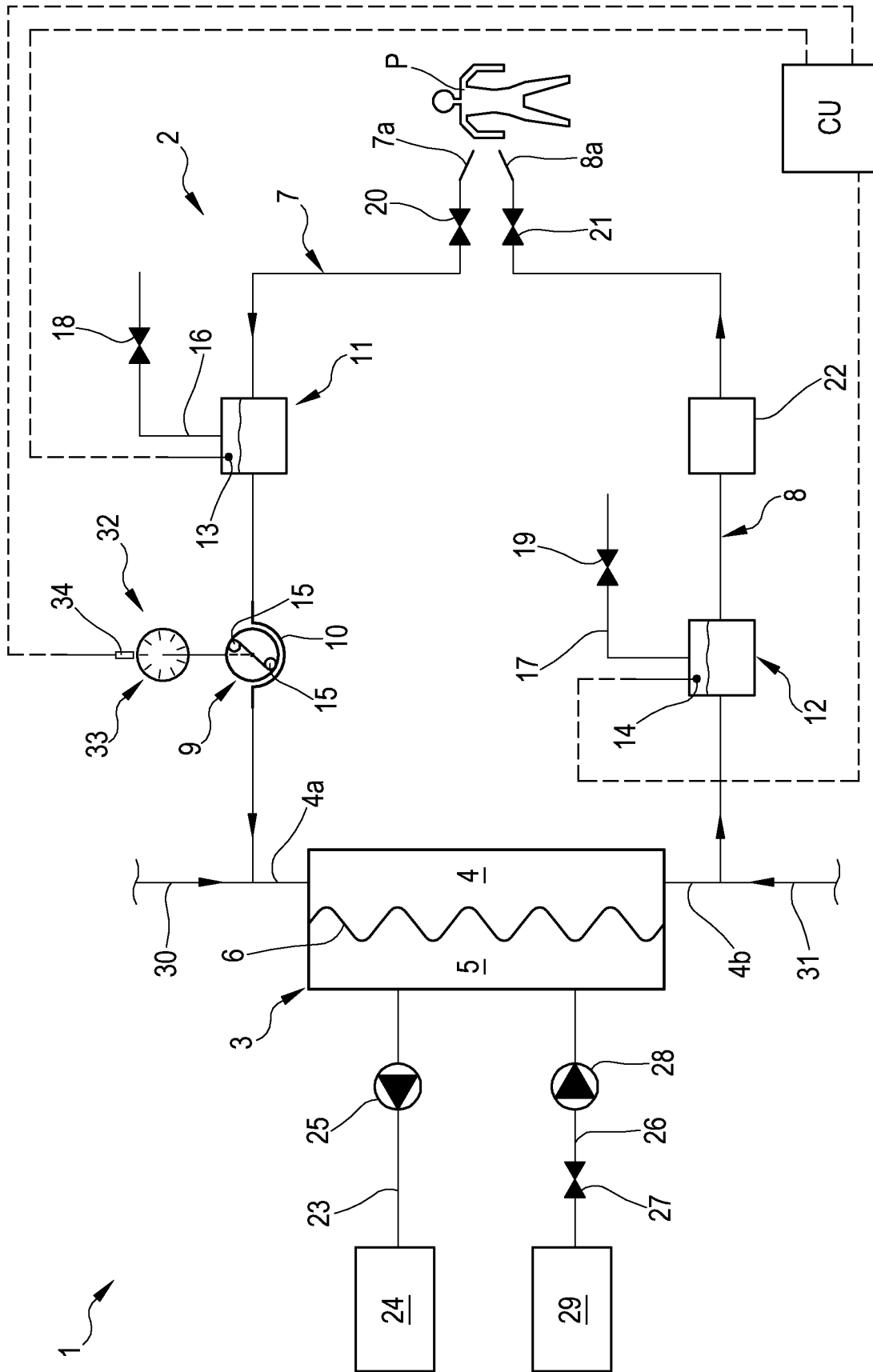
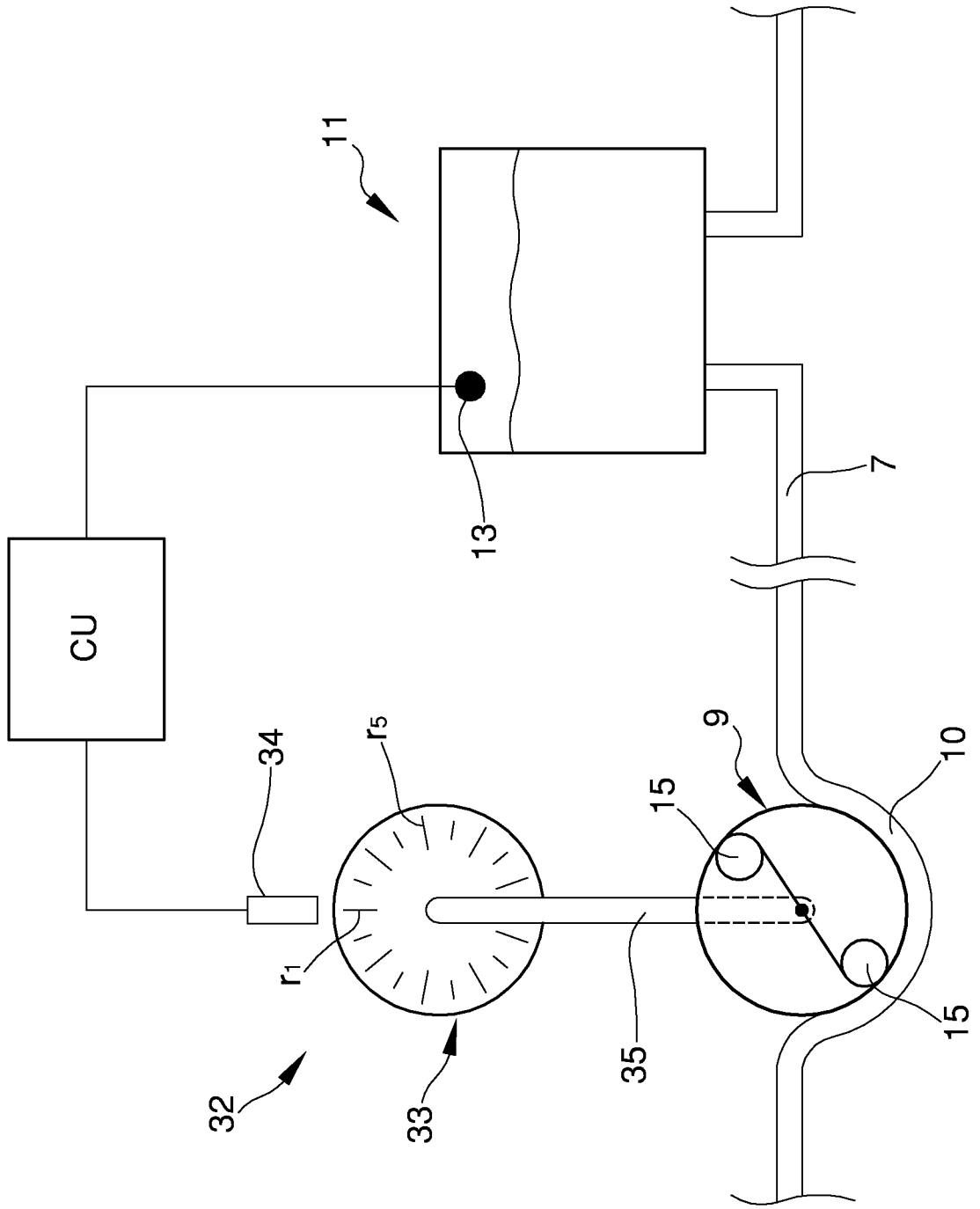

FIG.1

Fig. 2



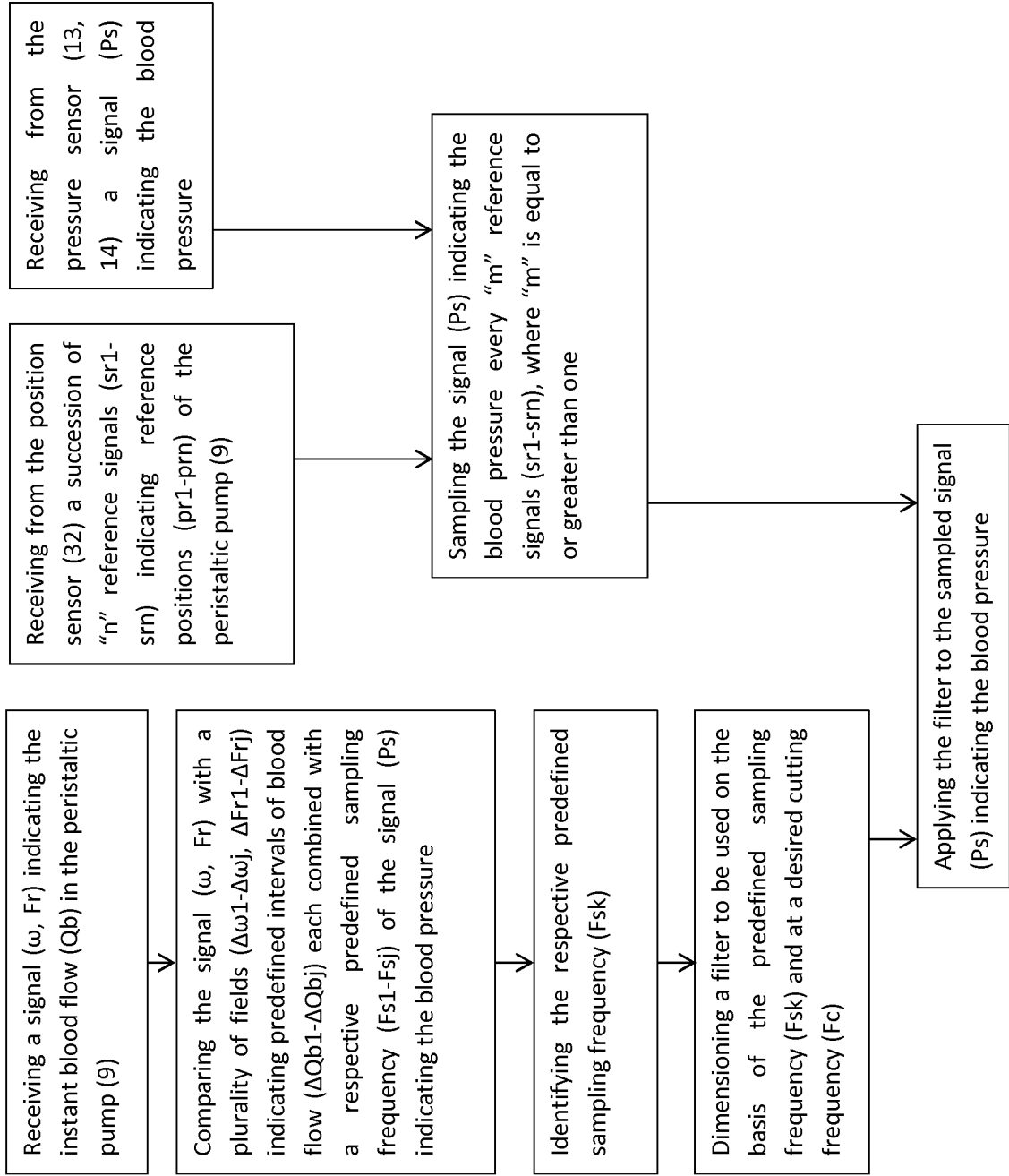

Fig.3

REFERENCES CITED IN THE DESCRIPTION

This list of references cited by the applicant is for the reader's convenience only. It does not form part of the European patent document. Even though great care has been taken in compiling the references, errors or omissions cannot be excluded and the EPO disclaims all liability in this regard.

Patent documents cited in the description

- US 2011301472 A [0004]
- WO 2013000777 A [0005]
- DE 10033192 [0005]
- WO 2008006559 A [0006]
- WO 03002174 A [0006]
- WO 2012175267 A [0006]

专利名称(译)	用于体外血液处理的装置		
公开(公告)号	EP2823834B1	公开(公告)日	2016-06-22
申请号	EP2013175841	申请日	2013-07-10
[标]申请(专利权)人(译)	甘布罗伦迪亚股份公司		
申请(专利权)人(译)	GAMBRO Lundia酒店		
当前申请(专利权)人(译)	GAMBRO Lundia酒店		
[标]发明人	STEFANI DAVID RUFFO MARIANO		
发明人	STEFANI, DAVID RUFFO, MARIANO		
IPC分类号	A61M1/36 A61B5/00 A61B5/021		
CPC分类号	A61M1/3639 A61B5/02141 A61B5/08 A61B5/4836 A61B5/6866 A61M1/16 A61M1/267 A61M1/36 A61M1/3607 A61M1/3653 A61M1/3656 A61M2205/3331 A61M2205/3344 A61M2205/3365 A61M2205 /52		
其他公开文献	EP2823834A1		
外部链接	Espacenet		

摘要(译)

描述了一种用于体外血液处理的装置 (1)，包括处理单元 (3)，所述处理单元 (3) 具有至少第一室 (4) 和至少第二室 (5)，所述第一室 (4) 和第二室 (5) 通过半透膜 (6) 彼此分开；至少一个血液清除管线 (7) 连接到第一腔室 (4) 的入口端口 (4a) 并预先设置以从患者 (P) 移除血液；至少一个血液返回管线 (8) 连接到第一腔室 (4) 的出口端口 (4b) 并预先设置以将处理过的血液返回患者 (P)，其中血液排出管线 (7)，血液返回管线 (8) 和第一腔室 (4) 是体外血液回路 (2) 的一部分；至少一个蠕动泵 (9) 在体外血液回路 (2) 上工作，用于移动回路中的血液；至少一个压力传感器 (13,14)，其与体外血液回路 (2) 相关联并且被配置为启用确定体外血液回路中的压力值 (2)；至少一个流体排出管线 (23)，连接到第二腔室 (5) 的出口；控制单元 (CU) 连接到至少一个压力传感器 (13,14) 和蠕动泵 (9)，并且构造成：以循环运动移动蠕动泵 (9) 以产生血流；从至少一个压力传感器 (13,14) 接收表示体外血液回路 (2) 中血液压力的信号 (Ps)。当蠕动泵 (9) 处于多个预定位置 (pp1-ppy) 时，根据蠕动泵 (9) 的速度 (ω) 以时域频率检测表示血压的信号 (Ps)。因此，压力信号 (Ps) 在空间域中以恒定频率被采样 (在每个泵循环处恒定) 并且与速度无关。泵 (9)。

