

(19)



(11)

**EP 2 440 122 B1**

(12)

**EUROPEAN PATENT SPECIFICATION**

(45) Date of publication and mention of the grant of the patent:

**14.08.2019 Bulletin 2019/33**

(51) Int Cl.:

**A61B 5/02 (2006.01) A61B 5/00 (2006.01)**

(21) Application number: **10786978.6**

(86) International application number:

**PCT/US2010/038555**

(22) Date of filing: **14.06.2010**

(87) International publication number:

**WO 2010/144922 (16.12.2010 Gazette 2010/50)**

(54) **APPARATUS, COMPUTER-BASED DATA PROCESSING ALGORITHM AND COMPUTER STORAGE MEDIUM FOR POSITIONING AN ENDOVASCULAR DEVICE IN OR NEAR THE HEART**

VORRICHTUNG, COMPUTERGESTÜTZTER DATENVERARBEITUNGSALGORITHMUS UND COMPUTERSPEICHERMEDIUM ZUM POSITIONIEREN EINES ENDOVASKULÄREN GERÄTS IM ODER IN DER NÄHE DES HERZENS

APPAREIL, ALGORITHME INFORMATIQUE DE TRAITEMENT DE DONNÉES ET SUPPORT DE STOCKAGE INFORMATIQUE PERMETTANT DE POSITIONNER UN DISPOSITIF ENDOVASCULAIRE DANS OU À PROXIMITÉ DU COEUR

(84) Designated Contracting States:

**AL AT BE BG CH CY CZ DE DK EE ES FI FR GB GR HR HU IE IS IT LI LT LU LV MC MK MT NL NO PL PT RO SE SI SK SM TR**

(30) Priority: **12.06.2009 US 213474 P**

(43) Date of publication of application:

**18.04.2012 Bulletin 2012/16**

(60) Divisional application:

**19170101.0**

(73) Proprietor: **Bard Access Systems, Inc.**

**Salt Lake City, UT 84116 (US)**

(72) Inventor: **GRUNWALD, Sorin**

**75015 Paris (FR)**

(74) Representative: **Hoffmann Eitle**

**Patent- und Rechtsanwälte PartmbB  
Arabellastraße 30  
81925 München (DE)**

(56) References cited:

<b>WO-A1-2004/002303</b>	<b>US-A- 5 121 750</b>
<b>US-A- 5 121 750</b>	<b>US-A1- 2004 097 805</b>
<b>US-A1- 2007 167 738</b>	<b>US-A1- 2007 299 352</b>
<b>US-A1- 2007 299 352</b>	<b>US-A1- 2008 097 232</b>

- **MAURO PITTIRUTI ET AL:** "The EKG Method for Positioning the Tip of PICCs: Results from Two Preliminary Studies", **JOURNAL OF THE ASSOCIATION FOR VASCULAR ACCESS, ELSEVIER, US**, vol. 13, no. 4, 1 January 2008 (2008-01-01), pages 179-186, XP008165474, ISSN: 1557-1289, DOI: 10.2309/JAVA.13-4-4 [retrieved on 2012-12-07]
- **YUNSEOK JEON ET AL:** "Évaluation écho cardiographique transoesophagienne de la mise en place d'un cathéter veineux central guidée par ECG", **CANADIAN JOURNAL OF ANESTHESIA**, vol. 53, no. 10, 1 October 2006 (2006-10-01), pages 978-983, XP055064968, ISSN: 0832-610X, DOI: 10.1007/BF03022525
- **M. STAS ET AL:** "Peroperative intravascular electrographic control of catheter tip position in access ports placed by venous cut-down technique", **EUROPEAN JOURNAL OF SURGICAL ONCOLOGY**, vol. 27, no. 3, 1 April 2001 (2001-04-01), pages 316-320, XP055084786, GB ISSN: 0748-7983, DOI: 10.1053/ejso.2000.1047
- **PITTIRUTI ET AL. THE EKG METHOD FOR POSITIONING THE TIP OF PICCS: RESULTS FROM PRELIMINARY STUDIES** vol. 13, no. 4, 2008, XP008165474
- **STAS ET AL.:** 'Peroperative intervascular electrographic control of catheter tip position in access ports placed by venous cut-down technique' **EJSO** vol. 27, 2001, pages 316 - 320, XP055084786

Note: Within nine months of the publication of the mention of the grant of the European patent in the European Patent Bulletin, any person may give notice to the European Patent Office of opposition to that patent, in accordance with the Implementing Regulations. Notice of opposition shall not be deemed to have been filed until the opposition fee has been paid. (Art. 99(1) European Patent Convention).

**EP 2 440 122 B1**

## Description

### FIELD OF THE INVENTION

**[0001]** The present invention relates to an endovascular device positioning. Specifically, the present invention relates to a method for positioning the tip of an endovascular device, such as a central venous catheter, in and around the heart using electrocardiogram (ECG) signals.

### BACKGROUND OF THE INVENTION

**[0002]** The electrical conduction system of the heart creates specific electrical signals, electrical energy distributions and behaviors thereof which are indicative of specific locations in the thoracic cavity and/or of specific heart functions or conditions. When measured endovascularly, i.e., from within blood vessels or from within the heart, certain parameters of the electrical activity of the heart can be used to identify specific locations in the cardiovascular system and/or functional conditions, normal or abnormal. Moreover, by locally and accurately identifying the location and the type of condition, therapy of such conditions can be optimized and the effect of the therapy monitored in real-time.

**[0003]** Two types of clinical applications are typically addressed. The first is related to guiding endovascular devices through the cardiovascular system, while the second is related to the non-invasive or the minimally invasive remote monitoring of the electrical activity of the heart.

**[0004]** The guidance, positioning, and placement confirmation of endovascular catheters are necessary in a number of clinical applications, such as, for example:

1. Central venous access, e.g., CVC, PICC, implantable ports;
2. Hemodialysis catheters;
3. Placement of pacemaker leads;
4. Hemodynamics monitoring catheters, e.g., Swan-Ganz and central pressure monitoring catheters; and
5. Guiding guidewires and catheters into the left heart.

**[0005]** The location of the catheter tip is very important to the patient safety, the duration and the success of the procedure. Today's golden standard for confirming the target location of the catheter tip is the chest X-ray. In addition, there are currently two types of real-time guiding products available on the market, which try to overcome the limitations of chest X-ray confirmation: electromagnetic and ECG-based. In hospitals where real-time guidance is used results have improved in terms of reducing the number of X-rays, the procedure time, and the cost of the procedure. Under real-time guidance first-time success rate has typically increased from 75%-80% to 90%-95%. In addition, in hospitals where ECG guidance is used, e.g., in Italy, Belgium, Germany, chest X-ray con-

firmation has been eliminated for more than 90% of the patients. Electromagnetic systems are used mostly in the United States while ECG-based systems are used mostly in Europe. Amongst other factors which determine the difference between the markets in the United States and Europe in terms of technology adoption: a) type of health care personnel allowed to perform procedures: nurses have more flexibility in the United States, b) type of devices placed: PICCs are placed more and more often in the United States, c) price sensitivity: the European market seems to be more price sensitive, and d) the current guiding devices are commercialized by specific manufacturers to work exclusively with their catheters: market penetration of the guiding systems reflects the market penetration of the catheter manufacturer.

**[0006]** It was also found that different opinions exist regarding where the target tip location should be: for example, lower third of the SVC or RA. Therefore guiding technologies should allow for discrimination of these locations. The chest X-ray, which is the current golden standard does not always allow for such discrimination requiring an accuracy of typically better than 2 cm. Also, because ECG-based systems make use of physiological information related to the heart activity, their ability to guide placement is accurate with respect to the anatomy. This is not the case with electromagnetic guiding systems which measure the distance between the catheter tip in the vasculature and an external reference placed typically on the patient's chest. Because of this aspect, ECG-based systems can be used to document the final result of the catheter placement potentially replacing the chest X-ray as the golden standard.

**[0007]** One of the most valuable diagnostic tools available, the ECG records the heart's electrical activity as waveforms. By interpreting these waveforms, one can identify rhythm disturbances, conduction abnormalities, and electrolyte imbalance. An ECG aids in diagnosing and monitoring such conditions as acute coronary syndromes and pericarditis. The heart's electrical activity produces currents that radiate through the surrounding tissue to the skin. When electrodes are attached to the skin, they sense these electrical currents and transmit them the electrocardiograph. Because the electrical currents from the heart radiate to the skin in many directions, electrodes are placed at different locations on the skin to obtain a total picture of the heart's electrical activity. The electrodes are then connected to an electrocardiograph device, or computer, and record information from different perspectives, which are called leads and planes. A lead provides a view of the heart's electrical activity between two points or poles. A plane is a cross section of the heart which provides a different view of the heart's electrical activity. Currently, the interpretation of an ECG waveform is based on identifying waveform component amplitudes, analyzing and then comparing the amplitudes with certain standards. Modifications of these amplitude components are indicative of certain conditions, e.g., the elevation of the ST segment or of certain loca-

tions in the heart, e.g., the amplitude of the P-wave. In today's practice ECG monitors are widely used to record ECG waveforms. More and more often applications are made available for automatic identification of the ECG amplitude components. In certain cases tools are available for decision making support and for automatic interpretation of ECG amplitude components with respect to underlying heart conditions.

**[0008]** Remote patient monitoring is a well established medical field. Still remote monitoring of heart conditions is not as widely accepted as it would be need and possible. One of the reasons is related to the relatively complicated way of acquiring signals related to the heart activity, in particular ECG signals. Another important limiting factor of the current remote monitoring technologies is the use of communications channels, like the telephone line, which are difficult to interface with at both the patient and the physician ends.

**[0009]** US 5,121,750 describes a method and apparatus for locating a catheter adjacent to a pacemaker node of the heart. The placement of a catheter tip just before SA heart pacemaker node is a common and desired procedure in medicine, with the most serious complication being its accidental advancement of the beyond this point placing its tip into the heart, with often fatal complications. The catheter tip location just before SA heart pacemaker node is desired because is most often the safest and optimal location. The catheter described in this document is placed by a physician within a patient's body circulatory vessel and advanced towards the heart SA pacemaker node, using traditional medical procedures. From the distal tip of the catheter the endogenous electrical activity from the SA pacemaker node of the heart is monitored and transmitted via at least one insulated transmission line located within the catheter to an electronic catheter monitoring system located outside the body. As the catheter is advanced its tip moves within the patient's circulatory vessel. Simultaneously, the electronic catheter monitoring system monitors the natural pacemaker node potentials, obtained at the tip of the catheter, which increase as the node is approached and decrease as the node is passed. The electronic catheter monitoring system display indicates these monitored changes to the physician advancing the catheter. The information provided by the electronic catheter monitoring system is used by the physician to guide catheter placement and confirm its location at the desired location outside the heart before the SA node.

**[0010]** US 2007/0299352 A1 describes a non-contact cardiac mapping method that includes: (i) inserting a catheter into a heart cavity having an endocardium surface, the catheter including multiple, spatially distributed electrodes; (ii) measuring signals at the catheter electrodes in response to electrical activity in the heart cavity with the catheter spaced from the endocardium surface; and (iii) determining physiological information at multiple locations of the endocardium surface based on the measured signals and positions of the electrodes with respect

to the endocardium surface. Related systems and computer programs are also described.

**[0011]** WO 2004/002303 A1 describes a catheter which is guided along a blood vessel of a patient by the bipolar electrode functioning as a mobile sensor on the catheter tip connected to the electronic unit to monitor the advance of the catheter and determine any modification of successive signals received from the bipolar electrode in order to detect any deviation of the catheter tip from the required path along the blood vessel and to deliver control signals comprising a GO signal, a STOP signal or an END signal to respectively enable, interrupt or terminate the advance of the catheter. The bipolar electrode moreover serves to verify the contact of the catheter tip with the wall of the heart cavity of the patient by creating impulses and detecting the appearance of corresponding induced signals on a surface cardiogram of the patient. The combination of the bipolar electrode on the catheter with the electronic unit is said to provide a portable catheterization system particularly suitable for performing urgent cardiac catheterizations outside hospitals.

#### SUMMARY OF THE INVENTION

**[0012]** According to the present invention, there is provided an apparatus for positioning an endovascular device in or near the heart as set out in Claim 1. There is also provided a computer-based data processing algorithm for positioning an endovascular device in or near the heart as set out in Claim 18, and a computer storage medium as set out in Claim 19.

#### BRIEF DESCRIPTION OF THE DRAWINGS

##### **[0013]**

FIG. 1 is a block diagram that depicts an apparatus according to an embodiment of the present invention.

FIGS. 2A, 2B and 2C depict various endovascular adaptor devices.

FIG. 3 is a block diagram of an electronic module for acquisition and processing of endovascular electrocardiogram according to an embodiment of the present invention.

FIGS. 4A, 4B, 4C, and 4D depict electrode configurations that provide optimal acquisition of endovascular electrocardiogram according to various embodiments of the present invention. FIG. 4A depicts a single lead configuration, FIG. 4B depicts a modified 3-lead configuration with monitoring and guiding capabilities, FIG. 4C depicts a telemetry configuration with a single grounded lead, and FIG. 4D depicts one use of ECG monitors for guiding endovascular devices.

FIG. 5 illustrates exemplary electrocardiogram signal amplitudes at different locations in the central

venous system.

FIG. 6 illustrates exemplary electrocardiogram signal power spectra at different locations in the central venous system.

FIG. 7 illustrates exemplary electrocardiogram signal electrical energy distribution at different locations in the central venous system.

FIG. 8 depicts a graphical user interface according to an embodiment of the present invention.

FIG. 9 depicts a graphical user interface according to another embodiment of the present invention.

FIGS. 10A and 10B depict a exemplary printouts for the information displayed by the graphical user interface, according to an embodiment of the present invention.

FIG. 11 is a block diagram for a computer-based method for positioning an endovascular device in or near the heart using electrocardiogram signals.

FIG. 12 illustrates another decision support algorithm for a computer-based method for positioning an endovascular device in or near the heart using electrocardiogram signals, according to an alternative embodiment.

FIG. 13 illustrates the cardiac conduction system of the heart.

FIG. 14 illustrates electrical signal propagation in the conduction system of the heart.

FIG. 15 illustrates electrical activity in the cardiovascular system due to neuronal control system.

#### DETAILED DESCRIPTION OF EMBODIMENTS

**[0014]** The matter disclosed herein advantageously provide computer-based methods for positioning the tip of an endovascular device, such as a central venous catheter, in and around the heart using electrocardiogram (ECG) signals.

**[0015]** Disclosed herein is a computer-based method for positioning an endovascular device in or near the heart using electrocardiogram (ECG) signals. This computer-based method includes receiving an endovascular ECG signal, associated with an endovascular device, including a plurality of waveforms, each waveform having at least a P-wave component, processing the endovascular ECG signal, over a plurality of predetermined time periods, to calculate a P-wave amplitude and a spectral power for each predetermined time period, determining a maximum P-wave amplitude from the plurality of P-wave amplitudes, and an associated maximum spectral power from the plurality of spectral powers, associating the maximum P-wave amplitude and the maximum spectral power with a predetermined location in or near the heart, calculating a location of the endovascular device, for each predetermined time period, based on a ratio of the P-wave amplitude to the maximum P-wave amplitude and a ratio of the spectral power to the maximum spectral power, and displaying the location of the endovascular device to a user.

**[0016]** The method described above is adapted to simultaneously receive a skin ECG signal, associated with a skin ECG lead, including a plurality of waveforms, each waveform having at least a P-wave component, process the skin ECG signal, over the plurality of predetermined time periods, to calculate a skin P-wave amplitude and a skin spectral power for each predetermined time period, determine a maximum skin P-wave amplitude from the plurality of skin P-wave amplitudes, and an associated maximum skin spectral power from the plurality of skin spectral powers, associate the maximum skin P-wave amplitude and the maximum skin spectral power with the predetermined location in or near the heart, and calculate the location of the endovascular device, for each predetermined time period, based on a ratio of the endovascular P-wave amplitude to the maximum skin P-wave amplitude and a ratio of the endovascular spectral power to the maximum skin spectral power.

**[0017]** There has thus been outlined, rather broadly, certain methods in order that the detailed description thereof herein may be better understood, and in order that the present contribution to the art may be better appreciated.

**[0018]** In this respect, before explaining at least one embodiment of the invention in detail, it is to be understood that the invention is not limited in its application to the details of construction and to the arrangements of the components set forth in the following description or illustrated in the drawings. The invention is capable of embodiments in addition to those described and of being practiced and carried out in various ways. Also, it is to be understood that the phraseology and terminology employed herein, as well as the abstract, are for the purpose of description and should not be regarded as limiting.

**[0019]** As such, those skilled in the art will appreciate that the conception upon which this disclosure is based may readily be utilized as a basis for the designing of other structures, methods and systems for carrying out the several purposes of the present invention. It is important, therefore, that the claims be regarded as including such equivalent constructions insofar as they do not depart from the scope of the present invention.

**[0020]** The invention will now be described with reference to the drawing figures, in which like reference numerals refer to like parts throughout.

**[0021]** Embodiments of the present invention advantageously provide an inventive apparatus(es), computer-based data processing algorithms for obtaining and using endovascular ECGs in a number of clinical applications and settings. For example, once device can be used to guide endovascular devices in and around the heart, e.g., guiding central venous access devices in the superior vena cava, right atrium, and right ventricle. Such central venous access devices may include central venous catheters (CVC), peripherally inserted central catheters (PICC), implantable ports, hemodialysis catheters, tunneled catheters and others. Other devices which may benefit from guidance with the inventive apparatus are

temporary pacemaker leads placed through the central venous system. Catheters and guidewires used in left heart procedures may also benefit from the present invention by decreasing the amount of contrast and radiation required to guide these devices in position. In another example, the apparatus can be used for minimally invasive monitoring and assessing heart conditions based on its electrical activity, e.g., assessing preload in a heart cycle or monitoring ST segments and T-waves in congestive heart failure.

**[0022]** In one aspect of the invention, an apparatus is described consisting of sterile adaptors, an electronic module for signal acquisition, a computer module, software, and peripheral devices and connections. In one embodiment, the electronic module for signal acquisition can be dedicated to acquiring and processing endovascular electrical signals generated by the body (endovascular ECG), in another embodiment the electronic module can be dedicated to acquiring and processing endovascular ECGs as well as skin ECGs.

**[0023]** In one embodiment, the electronic module and the computer module can be separate modules, in another embodiment they can be integrated in the same module and enclosure, and yet in another embodiment they can communicate with each other via a wireless connection, such as Bluetooth. In one embodiment, the apparatus can contain an integrated printer, while in another embodiment the printer can be external and attached to the apparatus and the apparatus connected via network, e.g., wireless to other devices. In yet another embodiment the apparatus can be used for telemetry and for transmitting the endovascular electrograms to a remote location, e.g., via a telephone line, Internet, and/or wireless phone. Any combination of embodiments mentioned above is also possible.

**[0024]** In another aspect of the invention, various configurations allow the connection of endovascular devices, such as central venous access devices, to the electronic module for signal acquisition and processing. In one embodiment, the device consists of a connecting wire with two ends and special connectors at each end. At one end, the wire can be connected to a metal or nitinol guidewire or stylet as commonly available on the market. At the other end, the wire can be safely connected to the electronic module. In another embodiment, the device includes a coated guidewire, e.g., made of nitinol or stainless steel with uncoated distal and proximal ends and cm markings. In such an embodiment, the coated guidewire is inserted endovascularly, while the connecting wire is connected to the proximal end of the coated guidewire. In another embodiment, the device includes a catheter-syringe adaptor provided with an electrical connecting wire. At one end, the electrical connecting wire is in contact with the fluid, e.g., saline flowing within the catheter-syringe adapter. At the other end the connecting wire can be connected to the electronic module.

**[0025]** In another aspect of the invention, various electrode configurations allow for the optimal acquisition of

endovascular ECGs. In one embodiment, a single lead is used to provide information about the tip location of an endovascular device within the vasculature. In another embodiment a modified three lead configuration is used to provide simultaneous 3-lead monitoring of the heart activity at the same time with providing tip location information. In another embodiment a modified single lead configuration plus ground is used for telemetry and transferring information from the tip of the catheter remotely.

**[0026]** In another aspect of the invention algorithms are introduced for the analysis of the ECG waveforms and for supporting decision making based on these waveforms. These algorithms discriminate between different locations in the vasculature and assess body functions (systemic and at specific locations in the body), in particular heart functionality. In various embodiments, these algorithms use time domain analysis of waveforms: morphologic, for example shape; statistic, for example behavior.

**[0027]** In other embodiments, the algorithms use frequency domain analysis of waveforms: morphologic, for example shape; statistic, for example behavior. In further embodiments, signal energy analysis in time and frequency domains is also performed, morphologic and statistical. Fuzzy, statistical, and knowledge-based decision making are also contemplated by the present invention as decision support tools.

**[0028]** In another aspect of the invention, a user interface is provided that advantageously simplifies interpretation of data and workflow. In one, embodiment the user interface includes simplified graphics showing the location in the vasculature and in the heart of the tip of the endovascular device in use without showing any of the ECG waveforms. In another embodiment, the user interface shows, in real-time, the change in location of the tip of the endovascular device in use.

**[0029]** In another aspect of the invention, several inventive methods are presented which use the apparatus described herein in clinical applications. In one embodiment, a computer-based method is provided that guides central venous catheters (CVC, PICCs, hemodialysis, implantable ports, and others) using stylets, guidewires and saline solution to the superior vena cava, inferior vena cava, the right atrium, and the right ventricle. This method is advantageously less sensitive to patients with arrhythmias than the prior art, and represents an alternative to chest X-ray confirmation of tip location of central venous catheters in most clinical cases. In another embodiment, a computer-based method is provided that guides coated guidewires in the right and left heart. In another embodiment, a computer-based method is provided that guides the placement of temporary pacemaker leads through the central venous system. In another embodiment, a method is provided that is minimally invasive and monitors preload using depolarization and heart rhythms. In another embodiment, a method is provided that is minimally invasive and monitors arrhythmias using P-wave analysis. In another embodiment, a method is

provided that is minimally invasive and monitors heart failure using ST segment and T-wave analysis.

**[0030]** FIG. 1 is a block diagram that depicts an apparatus according to an embodiment of the present invention.

**[0031]** The apparatus 100 can be attached through an adaptor (120) to a large variety of commercially available and custom designed vascular access devices (110). Examples of such devices are: central venous catheters (CVC), peripherally inserted central catheters (PICC), implantable ports, tunneled catheters, hemodialysis catheters, guiding catheters for pacemaker leads, guidewires used for coronary and other vascular interventions, guiding catheters for coronary and other vascular interventions, stylets, syringe needles, and others. If the vascular access devices is a stylet, a guidewire, or a syringe needle, its material must be sufficiently electrically conductive, e.g., stainless steel or nitinol. In such a case the hook or the alligator clip adaptor according to the present invention should be used. If the vascular access devices is a catheter, than saline should be used to establish a conductive path through one of the catheter's lumens. In such a case, the syringe-catheter adaptor according to the present invention should be used.

**[0032]** The electronic module (130) receives electrical signals from the adaptor and from one or more other electrodes placed on the patient's skin (115). Alternatively, more than one adaptor can be used at the same time to connect to more than one endovascular device in order to provide different electrical signals to the electronic module. The use of skin electrodes is optional in certain device configurations. The electronic module processes the electrical signals and transmits them to a computer module (140) for further processing and other functions. In one embodiment the electronic module and the computer module can be packaged separately, in another embodiment they can be integrated in the same package. In one embodiment the connection between the electronic module and the computer module can be hardwired, in another embodiment it can be wireless, e.g., using Bluetooth.

**[0033]** The computer module processes the signals from the electronic module applying algorithms (170) as described by the current invention. The computer module can also be connected to peripherals (160), e.g., a printer or a label printer and storage devices and provides connectivity including wireless connectivity (150) to other computers or to the internet. The storage device can be used to store a database of knowledge and information regarding the application at hand. The connectivity interface can be used to update this database remotely with newest relevant knowledge and information, e.g., new clinical cases, new findings regarding the relationship between electrograms and heart conditions. The computer module supports a graphical user interface (180) optimized for the purpose of the clinical application at hand.

**[0034]** FIGS. 2A, 2B and 2C depict various endovascular adaptor devices.

**[0035]** FIG. 2A illustrates adaptors that can be made of an isolated conductive wire (255) made of copper or stainless steel having two ends: one end connected to a vascular access device (255), the other end connected to the electronic module (250). The end that connects to the vascular access devices includes a connector that may have several configurations. In one embodiment, the connector is a J-clip connector (230) with a spring for isolation purposes when the J tip is not extended. In another embodiment, the connector is an isolated alligator clip (220). In another embodiment, the connector is catheter-syringe adapter (210). One end of the catheter-syringe adapter (211) can connect to the catheter luer. The other end can connect (215) to a syringe. A metal insert (214), e.g., a metal ring is located inside the body of the adaptor, comes in contact with the saline solution as it flows from the syringe towards the catheter lumen. The metal insert is connected through the adapter wall to a wire (212) which in turn is connected to the connector (250). In one embodiment the connector (250) is secured through external isolation (241) and plugs into a secure plug in the electronic module. In another embodiment the connector (250) has an optimized nipple shape (242) allowing for an easy and safe connection of a standard ECG cable connector.

**[0036]** Figure 2B illustrates a new guidewire (260) which allows for collecting electrical information only at its distal end (261). The guidewire made of electrically conductive materials with good enough conductivity, e.g., stainless steel or nitinol. The guidewire is coated with an electrically isolating coating like conformal parylene coating over its entire length except at the distal end and at the proximal end. The catheter has length markings printed on it (262). The distal end which is an a-traumatic tip, either as a J-tip or in any other a-traumatic embodiment is not coated and it allows for electrical contact with the blood. The proximal end is not coated (263) and allows connectors like the ones in figure 2 (220 or 230) to be electrically connected to the guidewire.

**[0037]** Figure 2C illustrates another embodiment of a catheter-syringe adaptor. A plastic piece (270) consists of a shaped end (271) which can fit into a standard catheter luer or into it lumen. The shape and the material allow for a good contact between the end (271) and the inner wall of the luer or lumen such that fluid can flow without leakage and no air is introduced into the lumen in the process. The other end of the piece (272) is a luer type connector which can fit any standard syringe. The body of the adaptor or inner chamber (273) adapts the diameter of the luer (272) to the size of the inner catheter lumen (271) and provides for a connection of an electrically conductive element in the inner chamber to a wire connected to the outside of the chamber through a perforation in the chamber wall (274). The connection through the chamber wall is waterproof. When saline is injected through the adaptor, the connection (274) creates a waterproof conductive path between the saline and an outside wire. The adaptor (290) is a plastic piece

which interfaces two sizes of diameters (291) and (292). In one embodiment the end (271) of the adaptor (270) fits into the lumen end (291) of adaptor (290) and the other end (292) of adaptor (290) fits into the lumen of a catheter used to place implantable ports.

**[0038]** FIG. 3 is a block diagram of an electronic module (300) for acquisition and processing of endovascular electrocardiogram according to an embodiment of the present invention.

**[0039]** The patient connector interface (310) allows for connecting electrical leads to the patient (305). Any combination of skin electrodes and/or electrical connections to endovascular devices using the adaptors discussed above can be used. In one embodiment, the amplifier (320) is a four stage amplifier with variable gain, which can amplify electrical signals coming through the patient cable, for example, typical of electrocardiographic values. The analog-to-digital converter (330) converts the signals in digital format readable by the micro-processor (340). Any number and configurations of microprocessors, microcontrollers, digital signal processors can be used to implement the micro-processing function (340).

**[0040]** In one embodiment, a microcontroller is responsible for controlling the serial communication with a computer module (390) via the serial interface (370) or via the wireless interface (380) and a digital signal processor (DSP) is responsible for implementing one or several of the inventive algorithms described herein. Alternatively, a single processor can be used for both communication and processing.

**[0041]** The micro-processor (340) also receives commands from the computer module (390) and controls different elements of the electronic module, e.g., the amplifier (320) accordingly. The patient isolation block (350) decouples electrically the power (360) and the serial communication channel (370) from the patient interface (310) in order to ensure patient protection to electrical shock. In one embodiment the isolation block (350) can consist of a transformer and/or couplers, e.g. optical couplers.

**[0042]** FIGS. 4A, 4B, 4C, and 4D depict electrode configurations that provide optimal acquisition of endovascular electrocardiogram according to various embodiments of the present invention.

**[0043]** FIG. 4A depicts a single lead configuration with a reference electrode (410), for example attached to the patient's skin over the right arm and with the other electrode attached through an adaptor to an endovascular device (415). The reference electrode attached to the skin over the right arm is presented in this configuration for illustration purposes only. Other locations of the reference electrode are possible depending on the type of ECG required. The reference electrode over the right arm together with the tip of the endovascular device used with the adaptor can be similar to lead II of a standard ECG. In this case the ECGs obtained from the superior vena cava (401) and inferior vena cava (402) can be optimized. The reference electrode can be attached to the skin in

any other location in order to simulate other leads of the standard ECG. The reference electrode can be also connected to adaptors attached to other endovascular devices in order to obtain more local information from within the patient's heart (400).

**[0044]** FIG 4B depicts a modified 3-lead configuration, with monitoring and guiding capabilities, with 4 electrodes. Three (3) electrodes correspond to the standard ECG electrodes: right arm (RA, 420), left arm (LA, 425), and left leg (LL, 430) used as reference. The fourth electrode is attached through an adapter to the endovascular device (C, 435). In this configuration, the electronic module and the algorithm perform two functions simultaneously: the three standard electrodes (RA, LL, and LL) perform a monitoring function of the heart, while the C electrode (435) allow for recording the ECG at the tip of device.

**[0045]** FIG 4C depicts a telemetry configuration with a single grounded lead, including the configuration illustrated in FIG. 4A and a ground reference (450). This configuration can be used to transmit ECGs remotely through a telemetry system configuration.

**[0046]** FIG 4D depicts one use of ECG monitors for guiding endovascular devices. A standard ECG monitor is used having standard inputs RA (465), LA (460), and LL (470). LA (460) is connected to the left arm and LL (470) to the left leg of the patient. The RA input (465) is connected to a switch which can be used by the clinician to switch the RA input (465) between the RA electrode and the catheter (C) electrode 475. Thus either monitoring or guiding of catheter placement can be achieved alternatively.

**[0047]** FIG. 5 illustrates exemplary electrocardiogram signal amplitudes at different locations in the central venous system.

**[0048]** The heart (504), right atrium (501), superior vena cava (SVC) (502), and the inferior vena cava (IVC) (503) are illustrated. Location A is in the upper SVC, location B is in the lower third of the SVC, location C is at the caval-atrial junction, location D is in the right atrium, and location E is in the upper inferior vena cava.

**[0049]** Graph 510 illustrates an ECG waveform as a function of time at recorded at location A. The absolute amplitude of the waveforms is recorded on an amplitude scale (590). In the case of an endovascular ECG, the standard elements of the electrocardiogram are illustrated: the P-wave (560), the R-wave (570), and the T-wave (580). The amplitudes and shape at location A recorded with a lead configuration as in Figure 4D are similar to an electrocardiogram recorded at the skin level with the same electrode configuration.

**[0050]** Graph 520 illustrates an endovascular ECG depicted at location B. The amplitude at this location is higher than the one at location A but the overall shapes of the waveform are similar at location A and B.

**[0051]** Graph 530 illustrates an endovascular ECG depicted at location C. At location C at the caval-atrial junction, the amplitude of the waveform is yet higher than the

one at location B and the P-wave has dramatically changed becoming higher than the R-wave. This waveform is an indication of the proximity of the sino-atrial node.

**[0052]** Graph 540 illustrates an endovascular ECG depicted at location D. At location D in the right atrium, the amplitudes are similar to location C but the P-wave changes polarity becoming bi-polar. This is an indication that the measurement of the ECG occurs beyond the sino-atrial node.

**[0053]** Graph 550 illustrates an endovascular ECG depicted at location E. At location E in the inferior vena cava, the waveform is similar to the one at location A in terms of amplitude except the P-wave has reverse polarity. The differences in the ECG waveforms at different locations are used by the algorithms introduced herein to discriminate between the corresponding locations and to assess heart and blood vessel functionality.

**[0054]** FIG. 6 illustrates exemplary electrocardiogram signal power spectra at different locations in the central venous system, using a spectral scale (690).

**[0055]** The heart (604), right atrium (601), superior vena cava (SVC) (602), and the inferior vena cava (IVC) (603) are illustrated. Graph 610 illustrates an endovascular ECG spectrum depicted at location A. At location A, the spectrum (610) has the appearance of a single central frequency or single band (660) and with a frequency distribution spectral power and energy similar to those at skin level.

**[0056]** Graph 620 illustrates an endovascular ECG spectrum depicted at location B. At location B the frequency distribution has two major bands and a higher energy and spectral power than the one at location A.

**[0057]** Graph 630 illustrates an endovascular ECG spectrum at location C. At location C, there are multiple (3-4) major frequencies or principal spectral components distributed over a wider range of frequencies (670). This spectral distribution is indicative of the energy distribution around the sino-atrial node. The spectral power and signal energy have increased compared to location B.

**[0058]** Graph 640 illustrates an endovascular ECG spectrum depicted at location D. At location D the spectrum is wider and more broadband indicative of the electrical activity of the right atrium.

**[0059]** Graph 650 illustrates an endovascular ECG spectrum depicted at location E. The frequency spectrum at location E is similar to the one at location A. The differences in the spectral waveforms at different locations are used by the algorithms introduced herein to discriminate between the corresponding locations and to assess heart and blood vessel functionality.

**[0060]** FIG. 7 illustrates exemplary electrocardiogram signal electrical energy distribution at different locations in the central venous system. The heart (704), right atrium (701), superior vena cava (SVC) (702), and the inferior vena cava (IVC) (703) are illustrated. Graphs (710, 720, 730, 740, 750) depict the energy distribution at different locations (A, B, C, D and E, respectively) and the changes

in time are used by the algorithms introduced herein to discriminate between the corresponding locations and to assess heart and blood vessel functionality.

**[0061]** FIG. 8 depicts a graphical user interface according to an embodiment of the present invention.

**[0062]** Window (810) presents the ECG waveform in real-time as it is acquired by the electronic module using the attached electrode configuration. Window (820) is a reference window and shows a frozen waveform used to compare with the current window. In one embodiment, the reference waveform in window (820) can be obtained through the electrodes connected to the electronic module at a reference location of the catheter and/or using a reference configuration of the skin electrodes. For example, such a reference waveform can be the ECG recorded using an adaptor according to the present invention connected to an endovascular device placed at the caval-atrial junction. In a different embodiment, the reference waveform in window 820 can be a typical waveform at a certain location in the vasculature or of a certain heart condition as it is recorded in a database of waveforms and as it is stored in the storage medium of the computer system. If the electrode configuration allows for simultaneous heart monitoring and recording of electrograms using an endovascular device, window (830) shows one of the standard ECG leads for heart monitoring, while window (810) shows the ECG at the tip of the endovascular devices when connected to an adaptor, such as the ones discussed above.

**[0063]** The icon (870) is a representation of the heart, and the locations A through E (875) illustrate different locations in the heart and vascular system which can be discriminated by analyzing endovascular ECGs in accordance with the methods disclosed herein. As a location in the vasculature is identified by the algorithms, the corresponding place and letter on the icon (875) becomes highlighted or in some other way is made visible to the user. The bars (884), (885), and (886) show signal energy levels. The "E" bar (885) presents the amount of electrical energy computed from the ECG frequency spectrum at the current location of the tip of the endovascular device. The "R" bar (884) presents the amount of electrical energy computed from the ECG frequency spectrum at a reference location. The "M" bar (886) presents amount of electrical energy computed from the ECG frequency spectrum using the monitoring ECG signal from the skin electrodes. The window (840) depicts monitoring information, e.g., heart rate. Patient information (name, date of procedure and others) are shown in window (850). Window (860) contains system control elements like buttons and status information, e.g., scale, scroll speed, system parameters and system diagnostics.

**[0064]** FIG. 9 depicts a graphical user interface according to another embodiment of the present invention.

**[0065]** The icon (920) is a representation of the heart and the locations A through E (930) illustrate different locations in the heart and vascular system which can be

discriminated by analyzing endovascular ECGs. As a location in the vasculature is identified by the algorithms, the corresponding place and letter on the icon (930) becomes highlighted or in some other way is made visible to the user. The bars (940), (950), and (960) show signal energy levels. The "E" bar (940) depicts the amount of electrical energy computed from the ECG frequency spectrum at the current location of the tip of the endovascular device. The "R" bar (950) shows the amount of electrical energy computed from the ECG frequency spectrum at a reference location. The "M" bar (960) shows amount of electrical energy computed from the ECG frequency spectrum using the monitoring ECG signal coming from the skin electrodes. The button "Print" (960) allows the user to print the information documenting the case on a printer, for example on a label printer for quick attachment to the patient's chart.

**[0066]** FIGS. 10A and 10B depict an exemplary printouts for the information displayed by the graphical user interface, according to an embodiment of the present invention.

**[0067]** FIG. 10A illustrates a printout (1000) for the case of a catheter tip placement procedure in the lower third of the SVC. The field 1010 depicts the heart icon whereby the letter "B" corresponding to the lower third of the superior vena cava (SVC) is highlighted (1040). Field 1030 depicts the reference ECG waveform recorded at the tip of the catheter at the caval-atrial junction in the proximity of the sino-atrial node. Field 1020 depicts the ECG waveform at the tip of the catheter in the position in which it was placed at the end of the procedure. For FIG. 10A, this location is in the lower third of the SVC and the ECG waveform corresponds to this location. The patient name (1001) and the date of procedure (1002) are also printed.

**[0068]** FIG. 10B depicts a similar printout (1050) except that the final position at the end of the procedure is at the caval-atrial junction at location C (1090) on the heart icon (1060). The "SA Node" field depicts the reference ECG waveform (1080), and the "Final Position" field (1070) shows that the catheter was placed with the tip at the sino-atrial node: the ECG waveform in final location is similar or even identical with the one in the reference location at the sino-atrial node (SA Node). It is known that the proximity of the SA Node indicates a location at the caval-atrial junction. These locations are sometimes considered identical by some clinicians.

**[0069]** FIG. 11 is a block diagram for a computer-based method (1100) for positioning an endovascular device in or near the heart using electrocardiogram signals.

**[0070]** The algorithms are applied to the input signal (1102) (ECG) acquired by the adaptor to the endovascular devices and, optionally, through skin electrodes as well. The Error Detection Block (1105) detects at least three types of error conditions / exceptions, such as, for example, when a defibrillator has been applied to the patient, when a pacemaker is firing excitation pulses and/or when a lead/electrode is off. These errors / ex-

ceptions may be handled differently, and the user may be informed about the presence of an exception and the way of handling the exception (1110).

**[0071]** The Pre-Processing block (1115) may amplify the signal, reduce noise, eliminate artifacts, etc. In one embodiment, rescaling the signal to the display range occurs under user control and is not automatic, as with most currently available ECG monitors. Thus, changes in the amplitude of the ECGs are easily noticed. A high-pass filter corrects the baseline and reduces such artifacts as respiratory artifact. Wideband noise suppression may be achieved using a selective filter, e.g., a wavelet transform. Electromagnetic interference with other equipment and the power grid may be suppressed by a notch filter (narrow band filter) centered at 60 Hz or 50 Hz to accommodate domestic or international power supplies. High frequency noise may be suppressed with a low-pass filter, which, in one embodiment, is implemented with variable length averaging, such as, for example, a running window corresponding to a heart cycle, an averaging of the ECG over several consecutive heart cycles, etc. The Adaptive Filtering block (1120) optimizes the filter coefficients by minimizing an error signal.

**[0072]** The Time-Domain Pattern Recognition block (1130) identifies elements of the ECG waveform, their relationship(s) and their behavior(s) in time. An important aspect of the time-domain pattern recognition algorithm in block 1130, as well as of the Frequency Domain Pattern Recognition block 1140, is data history. The ECGs are analyzed in real time for certain elements, and, for other elements, a data buffer with an appropriate buffer length is maintained in the memory of the electronic and/or computer modules in order to allow for historic data analysis and prediction based on this analysis. In one embodiment, the data history buffer is several seconds long allowing for the ECG signal corresponding to several heartbeats to be saved in the buffer. A double buffering technique allows the waveform in one buffer to be processed while the second buffer continues to store signals. Thus no signal data are lost while the waveform in one buffer is processed. After data processing on one buffer is completed, the results are sent to the Decision Support Algorithms (1150) and the two buffers switch roles. The length of the buffer accommodates the time duration of data processing in order to ensure that no data are lost. A similar double buffering technique is also applied to the data subject to Frequency Domain Pattern Recognition block (1140).

**[0073]** In the case of an endovascular ECG, elements of interest may include, but are not limited to, one or more of the following:

1. The P, Q, R, S, T, and U waves, their peaks, amplitudes and duration;
2. The duration of the P-R, S-T, and T-P segments / intervals;
3. The elevation of the S-T segment;
4. The variances of the P-P and R-R intervals;

5. The variance of the S-T and of the R-T intervals, etc.;
6. The peak-to-peak values of the P-wave and of the QRS complex;
7. The ratio of the P-wave and R-wave amplitudes and the ratio of the P-wave and QRS complex peak-to-peak amplitudes;
8. The polarity of the P-wave: single positive, single negative, or bipolarity;
9. The derivative of the P-wave, QRS-complex, and T-wave;
10. Temporal average of the R-R interval and the heart beat;
11. Maximum value of the P-wave amplitude / peak and of the P-wave peak-to-peak amplitude over a certain period of time;
12. Maximum value of the R-wave amplitude / peak and of the ORS complex peak-to-peak amplitude over a certain period of time.

**[0074]** Several techniques may be used to derive the information listed above from the ECG waveforms, including, but not limited to, one or more of the following:

1. "Peak detection";
2. Computation of first derivatives;
3. Running averages along the signal in one heart-beat and along multiple heartbeats;
4. Adaptive thresholding;
5. Auto-correlation.

**[0075]** The Fast Fourier Transform in block (1125) performs a Fast Fourier Transform on a number of ECG samples stored in a buffer of a certain length, e.g., 256, 512, 1024, 2048 or more data samples. The Fourier Transform transforms the waveform from the time domain into the frequency domain.

**[0076]** The Frequency-Domain Pattern Recognition block (1140) illustrates various aspects of pattern recognition performed on the ECGs in the frequency domain, including, but not limited to, one or more of the following:

1. Principal components analysis, i.e., determination of the most significant elements of the frequency spectrum (similarly to determining the morphological elements of the electrograms, e.g., certain waves and segments in time domain);
2. Data compression in order to reduce the amount of computation based on the principal components;
3. Determination of the number and morphology of the principal components, in particular determination if the spectrum has only one, two or multiple main frequencies (frequency bands);
4. Calculation of the spectral power and of the signal energy from the frequency spectrum;
5. Running average along the frequency dimension over a single spectrum in order to reduce wideband noise;

6. Running average along several spectra in order to filter out artifacts;
7. Determination of additional morphological elements of the spectrum, e.g., the maximum frequency, the energy contained in the maximum frequency, the frequency histogram, i.e., what frequencies contain how much energy, the frequency of the highest significant maximum energy peak, etc.;
8. Calculation of behavior and averages over time of the principal components and other parameters determined from the spectral distribution, e.g., determining the maximum value of the signal energy and of the spectral power over a certain period of time;
9. Determine / estimate certain heart conditions based on the spectral analysis. This determination / estimation is also performed in more detailed in the decision support blocks 1150 and 1250.

**[0077]** Several decision support algorithms use the information provided by the time domain pattern recognition and frequency-domain pattern recognition algorithms. In one embodiment, block (1150) supports placing an endovascular device in either the lower third of the SVC or at the caval-atrial junction.

**[0078]** In particular, block 1150 is based on the concept of first reaching the caval-atrial junction during catheter placement. At the caval-atrial junction or near the sino-atrial node the P-wave and other electrical parameters reach a maximum value. At the caval-atrial junction the P-wave is unipolar. After reaching the sino-atrial node at the caval-atrial junction, i.e., the maximum value of the P-peak amplitude and spectral power, the catheter is pulled back several centimeters until the P-wave decreases to half the amplitude reached at the caval-atrial junction. At the location where the P-wave has decreased to half the amplitude as the caval-atrial junction, the catheter is considered to be in the lower third of the superior vena cava. The P-wave peak amplitude or peak-to-peak amplitude, as well as the spectral power, is used to map the location in the vasculature to the ECG waveform.

**[0079]** More particularly, after receiving an endovascular ECG signal associated with an endovascular device, the signal is processed, over a plurality of predetermined time periods, to calculate a P-wave amplitude and a spectral power for each predetermined time period. A maximum P-wave amplitude is then determined from the plurality of P-wave amplitudes, as well as an associated maximum spectral power from the plurality of spectral powers. The location at which these maximum values are determined is associated with a predetermined location in or near the heart, such as the cava-atrial junction. The location of the endovascular device is then calculated, for each predetermined time period, based on a ratio of the P-wave amplitude to the maximum P-wave amplitude and a ratio of the spectral power to the maximum spectral power, and the location of the endovascular device is then displayed to the user. Additionally, the polarity

of the P-wave and the R-wave amplitude may also be used to determine the location of the endovascular device.

**[0080]** A single criterion or a combination of such criteria can be used to support decision making. In one embodiment, T1, T2, and T3 may be empirically established thresholds which are different for each patient, and the algorithm can use an adaptive loop to adjust the thresholds based on the current measurements. In another embodiment, these thresholds are predetermined.

**[0081]** In alternative embodiments, the ratio between the P-peak / P amplitude or the P-wave peak-to-peak amplitude to the R-peak / R amplitude or to the QRS complex peak-to-peak amplitude can also be used to establish location relative to the sino-atrial node. In one embodiment the P-peak / amplitude must be approximately half of the R-peak / amplitude and the P-wave must be unipolar for the location to correspond to the lower third of the SVC. In another embodiment, the P-wave peak-to-peak must be half of the QRS peak-to-peak amplitude and the P-wave must be unipolar for the location to correspond to the lower third of the SVC.

**[0082]** As discussed above, the results of the decision support algorithms block 1150 may be presented to the user, for example, by high lightening the appropriate location on the heart icon corresponding to the type of ECG identified by the system (1160).

**[0083]** The decision support algorithm block 1250, depicted in FIG. 12, is based on comparing the P-wave, R-wave and P-wave spectral power at the current locations with the values of these parameters determined from the skin electrocardiograms in an equivalent lead, e.g., lead II. Thresholds T1 through T6 are empirical values subject to adaptive adjustments relative to each patient. Each of the criteria or a combination of criteria shown in FIG. 12 can be used.

**[0084]** Other decision algorithms can also be used, in particular related to the level of electrical energy as calculated from the ECG spectrum. In the case of placing endovascular devices, one criterion may be that, at the location corresponding to the lower third of the SVC, the average electrical energy calculated from the endovascular ECG is twice as high as the average electrical energy calculated from the endovascular ECG at skin level or from a skin ECG in a corresponding lead, e.g., lead II.

**[0085]** FIG. 13 illustrates the cardiac conduction system of the heart, while FIG. 14 illustrates electrical signal propagation in the conduction system of the heart.

**[0086]** These figures illustrate the conductive mechanism of the heart, which explains why the electrical energy distribution within the heart as measured is indicative of specific locations within the heart. Accordingly, local electrical signals, behaviors and energy concentrations can be measured and locations within the heart and blood vessel can be determined more accurately; local heart conditions can also be described more accurately.

**[0087]** The conduction system of the heart begins with the heart's dominant pacemaker, the sino-atrial node

(1310). The intrinsic rate of the SA node is 60 to 100 beats/minute. When an impulse leaves the SA node, it travels through the atria along the Bachmann's bundle (1350) and the inter-nodal pathways, on its way to the atro-ventricular (AV) node (1320) and ventricles. After the impulse passes through the AV node, it travels to the ventricles, first down to the bundle of His (1330) then along the bundle branches and finally down to the Purkinje fibers (1340). Pacemaker cells in the junctional tissue and Purkinje fibers on the ventricles normally remain dormant because they receive impulses from the SA node. They initiate an impulse only they do not receive one from the SA node. The intrinsic rate of the AV junction is 40 to 60 beats/minute, the intrinsic rate of the ventricles 20 to 40 beats/minute. The different propagation speeds of the electrical impulses are shown in Figure 14. From the SA node (1410) the impulses propagate through the atrial muscle (1420) and through the ventricular muscle (1460) at app. 0.5 ms, through the bundle branches (1440) and (1450) at app. 2 m/sec, through the Purkinje fibers (1470) at app 4 m/s and through the AV node (1430) at app. 0.05 m/s.

**[0088]** The electrical signals and the electrical energy distribution are advantageously used to identify the proximity of the sino-atrial node and right atrial electrical activity even in the cases of arrhythmia, i.e., in the absence of a coherent P-wave measured by standard skin electrocardiogram. While in some cases of arrhythmia random electrical signal generated in the right atrium is not coherent enough to propagate through the body to the skin, the electrical energy is still present in the right atrium and can be detected by local endovascular measurements as a non-coherent P-wave, i.e., as significant electrical activity in the P-segment of the ECG waveform. Energy measurements are also less sensitive to some local abnormalities in impulse conduction: altered automaticity (arrhythmias), retrograde conduction of impulses, reentry abnormalities.

**[0089]** The electrical signals and the electrical energy distribution are also advantageously used to quantify heart functionality, e.g., preload which is related to the depolarization and extension of the heart muscle.

**[0090]** The electrical signals and the electrical energy distribution are also advantageously used to guide guidewires and guiding catheters through the aorta into the left heart. This method is useful in simplifying the access to the left atrium and to the coronary arteries and in reducing the amount of contrast and radiation needed to guide endovascular devices to those locations. In a different application, the inventive apparatus can also be used to guide catheters, e.g., Swan-Ganz through the right ventricle into the pulmonary artery. Other endovascular devices can be guided and be used to measure endovascular electrical activity in other locations of the cardiovascular system which are identifiable by the cardiograms measured with the new apparatus introduced in the present invention.

**[0091]** FIG. 15 illustrates electrical activity in the car-

diovascular system due to neuronal control system. Several paths of conduction are related to the mechanism of control of heart (1530) and blood vessel (1520) activity: receptors (1510), e.g., pressure receptors transmit information related to the state of the blood vessels and to the state of the heart to the nervous system through the Medullary centers (1500). The hypothalamus (1540) and the higher centers (1550) are involved in processing and reacting to the information received from the sensors/receptors. In turn they send impulses (1560) back to blood vessels and the heart. By measuring electrical activity related to the control system, information regarding heart conditions can be obtained which could not have been obtained previously.

[0092] The scope of the invention is defined by the claims.

**Claims**

- 1. An apparatus (100) for positioning an endovascular device (110) in or near the heart (400; 504; 604; 704) using electrocardiogram (ECG) signals, comprising an electronic module (130; 250; 300) for carrying out the steps of:

- receiving an endovascular ECG signal, associated with the endovascular device, including a plurality of waveforms, each waveform having at least a P-wave component;

**characterized in that**

- the apparatus further comprises a computer module (140; 390) for carrying out the steps of:

- processing the endovascular ECG signal, over a plurality of predetermined time periods, to calculate a P-wave amplitude and a spectral power for each predetermined time period;

- determining a maximum P-wave amplitude from the plurality of P-wave amplitudes, and an associated maximum spectral power from the plurality of spectral powers;

- associating the maximum P-wave amplitude and the maximum spectral power with a predetermined location in or near the heart;

- calculating a location of the endovascular device, for each predetermined time period, based on a ratio of the P-wave amplitude to the maximum P-wave amplitude and a ratio of the spectral power to the maximum spectral power; and

- displaying the location of the endovascular device to a user.

- 2. The apparatus (100) according to claim 1, wherein the P-wave amplitude is a peak-to-peak value, and

the maximum P-wave amplitude is a peak-to-peak value.

- 3. The apparatus (100) according to claim 2, wherein said processing the ECG signal includes determining a polarity for each P-wave amplitude, and said calculating the location of the endovascular device is also based on the P-wave polarity for each predetermined time period.

- 4. The apparatus (100) according to claim 3, wherein the predetermined location is the caval-atrial junction (C).

- 5. The apparatus (100) according to claim 4, wherein the location of the endovascular device (110) is the upper superior vena cava (A) if the ratio of the P-wave amplitude to the maximum P-wave amplitude is less than 0.4, the ratio of the spectral power to the maximum spectral power is less than 0.4, and the P-wave polarity is unipolar.

- 6. The apparatus (100) according to claim 5, wherein the location of the endovascular device (110) is the lower third of the superior vena cava (B) if the ratio of the P-wave amplitude to the maximum P-wave amplitude is between 0.4 and 0.6, the ratio of the spectral power to the maximum spectral power is between 0.4 and 0.6, and the P-wave polarity is unipolar.

- 7. The apparatus (100) according to claim 6, wherein the location of the endovascular device (110) is the caval-atrial junction (C) if the ratio of the P-wave amplitude to the maximum P-wave amplitude is greater than 0.9, the ratio of the spectral power to the maximum spectral power is greater than 0.9, and the P-wave amplitude is greater than the R-wave amplitude.

- 8. The apparatus (100) according to claim 7, wherein the location of the endovascular device (110) is the right atrium (D) if the ratio of the spectral power to the maximum spectral power is between 0.6 and 0.9, and the P-wave polarity is bipolar.

- 9. The apparatus (100) according to claim 8, wherein the location of the endovascular device (110) is the upper third of the inferior vena cava if the ratio of the P-wave amplitude to the maximum P-wave amplitude is between 0.4 and 0.6, the ratio of the spectral power to the maximum spectral power is between 0.4 and 0.6, and the P-wave polarity is unipolar with reversed polarity.

- 10. The apparatus (100) according to claim 4, wherein the endovascular device (110) is a central venous catheter coupled to an adapter (210) that includes

an electrode in contact with a saline solution column exposed to the tip of the catheter, and the endovascular ECG signal is based on an electrical signal measured by the electrode.

- 11. The apparatus (100) according to claim 10, further comprising means for carrying out the steps of:

simultaneously receiving a skin ECG signal, associated with a skin ECG lead (410; 420; 425; 430; 440; 460; 465; 470), including a plurality of waveforms, each waveform having at least a P-wave component; processing the skin ECG signal, over the plurality of predetermined time periods, to calculate a skin P-wave amplitude and a skin spectral power for each predetermined time period; determining a maximum skin P-wave amplitude from the plurality of skin P-wave amplitudes, and an associated maximum skin spectral power from the plurality of skin spectral powers; associating the maximum skin P-wave amplitude and the maximum skin spectral power with the predetermined location in or near the heart (400; 504; 604; 704); and calculating the location of the endovascular device (110), for each predetermined time period, based on a ratio of the endovascular P-wave amplitude to the maximum skin P-wave amplitude and a ratio of the endovascular spectral power to the maximum skin spectral power.

- 12. The apparatus (100) according to claim 11, wherein the location of the endovascular device (110) is the upper superior vena cava (A) if the ratio of the endovascular P-wave amplitude to the maximum skin P-wave amplitude is between 0.9 and 1.2, the ratio of the endovascular spectral power to the maximum skin spectral power is between 0.9 and 1.2, and the P-wave polarity is unipolar.

- 13. The apparatus (100) according to claim 12, wherein the location of the endovascular device (110) is the lower third of the superior vena cava if the ratio of the endovascular P-wave amplitude to the maximum skin P-wave amplitude is between 1.5 and 2.0, the ratio of the endovascular spectral power to the maximum skin spectral power is between 1.5 and 2.0, and the P-wave polarity is unipolar.

- 14. The apparatus (100) according to claim 13, wherein the location of the endovascular device (110) is the caval-atrial junction (C) if the ratio of the endovascular P-wave amplitude to the maximum skin P-wave amplitude is greater than 2.5, the ratio of the spectral power to the maximum spectral power is greater than 2.59, and the endovascular P-wave amplitude is greater than the endovascular R-wave amplitude.

- 15. The apparatus (100) according to claim 14, wherein the location of the endovascular device (110) is the right atrium (D) if the ratio of the endovascular spectral power to the maximum skin spectral power is between 2.0 and 2.5, and the endovascular P-wave polarity is bipolar.

- 16. The apparatus (100) according to claim 15, wherein the location of the endovascular device (110) is the upper third of the inferior vena cava if the ratio of the endovascular P-wave amplitude to the maximum skin P-wave amplitude is between 0.9 and 1.2, the ratio of the endovascular spectral power to the maximum skin spectral power is between 0.9 and 1.2, and the P-wave polarity is unipolar with reversed polarity.

- 17. The apparatus (100) according to claim 1, wherein the P-wave is a P-segment.

- 18. A computer-based data processing algorithm for positioning an endovascular device (110) in or near the heart (400; 504; 604; 704) using electrocardiogram (ECG) signals, the computer-based data processing algorithm, when applied by a computer, causes the computer to carry out the steps of:

receiving an endovascular ECG signal, associated with the endovascular device, including a plurality of waveforms, each waveform having at least a P-wave component; **characterized in that** the data processing algorithm, when applied by the computer, causes the computer to carry out the steps of:

processing the endovascular ECG signal, over a plurality of predetermined time periods, to calculate a P-wave amplitude and a spectral power for each predetermined time period; determining a maximum P-wave amplitude from the plurality of P-wave amplitudes, and an associated maximum spectral power from the plurality of spectral powers; associating the maximum P-wave amplitude and the maximum spectral power with a predetermined location in or near the heart; calculating a location of the endovascular device, for each predetermined time period, based on a ratio of the P-wave amplitude to the maximum P-wave amplitude and a ratio of the spectral power to the maximum spectral power; and displaying the location of the endovascular device to a user.

- 19. A computer storage medium having stored thereon

the computer-based data processing algorithm according to claim 18.

### Patentansprüche

1. Einrichtung (100) zum Positionieren einer endovaskulären Vorrichtung (110) im Herz oder in der Nähe des Herzens (400; 504; 604; 704) unter Verwendung von Elektrokardiogramm-(EKG)-Signalen, umfassend ein elektronisches Modul (130; 250; 300) zum Ausführen der folgenden Schritte:

Empfangen eines endovaskulären EKG-Signals, das der endovaskulären Vorrichtung zugeordnet ist, einschließlich einer Vielzahl von Wellenformen, wobei jede Wellenform mindestens eine P-Wellenkomponente aufweist;  
**dadurch gekennzeichnet, dass**  
 die Einrichtung weiter ein Computermodul (140; 390) umfasst, um die folgenden Schritte auszuführen:

Verarbeiten des endovaskulären EKG-Signals über eine Vielzahl von vorbestimmten Zeitdauern, um eine P-Wellenamplitude und eine Spektralleistung für jede vorbestimmte Zeitdauer zu berechnen;  
 Bestimmen einer maximalen P-Wellenamplitude aus der Vielzahl von P-Wellenamplituden und einer zugeordneten maximalen Spektralleistung aus der Vielzahl von Spektralleistungen;  
 Zuordnen der maximalen P-Wellenamplitude und der maximalen Spektralleistung zu einer vorbestimmten Position im Herz oder in der Nähe des Herzens;  
 Berechnen einer Position der endovaskulären Vorrichtung für jede vorbestimmte Zeitdauer basierend auf einem Verhältnis der P-Wellenamplitude zur maximalen P-Wellenamplitude und einem Verhältnis der Spektralleistung zur maximalen Spektralleistung; und  
 Anzeigen der Position der endovaskulären Vorrichtung an einen Benutzer.

2. Einrichtung (100) nach Anspruch 1, wobei die P-Wellenamplitude ein Spitze-zu-Spitze-Wert ist und die maximale P-Wellenamplitude ein Spitze-zu-Spitze-Wert ist.
3. Einrichtung (100) nach Anspruch 2, wobei das Verarbeiten des EKG-Signals das Bestimmen einer Polarität für jede P-Wellenamplitude einschließt und das Berechnen der Position der endovaskulären Vorrichtung auch auf der P-Wellenpolarität für jede vorbestimmte Zeitdauer basiert.

4. Einrichtung (100) nach Anspruch 3, wobei die vorbestimmte Position die Kaval-Atrial-Verbindung (C) ist.
5. Einrichtung (100) nach Anspruch 4, wobei die Position der endovaskulären Vorrichtung (110) die obere Hohlvene (A) ist, wenn das Verhältnis der P-Wellenamplitude zur maximalen P-Wellenamplitude kleiner als 0,4 ist, das Verhältnis der Spektralleistung zur maximalen Spektralleistung kleiner als 0,4 ist und die P-Wellenpolarität unipolar ist.
6. Einrichtung (100) nach Anspruch 5, wobei die Position der endovaskulären Vorrichtung (110) das untere Drittel der oberen Hohlvene (B) ist, wenn das Verhältnis der P-Wellenamplitude zur maximalen P-Wellenamplitude zwischen 0,4 und 0,6 liegt, das Verhältnis der Spektralleistung zur maximalen Spektralleistung zwischen 0,4 und 0,6 liegt und die P-Wellenpolarität unipolar ist.
7. Einrichtung (100) nach Anspruch 6, wobei die Position der endovaskulären Vorrichtung (110) die Kaval-Atrial-Verbindung (C) ist, wenn das Verhältnis der P-Wellenamplitude zur maximalen P-Wellenamplitude größer als 0,9 ist, das Verhältnis der Spektralleistung zur maximalen Spektralleistung größer als 0,9 ist und die P-Wellenamplitude größer als die R-Wellenamplitude ist.
8. Einrichtung (100) nach Anspruch 7, wobei die Position der endovaskulären Vorrichtung (110) das rechte Atrium (D) ist, wenn das Verhältnis der Spektralleistung zur maximalen Spektralleistung zwischen 0,6 und 0,9 liegt und die P-Wellenpolarität bipolar ist.
9. Einrichtung (100) nach Anspruch 8, wobei die Position der endovaskulären Vorrichtung (110) das obere Drittel der unteren Hohlvene ist, wenn das Verhältnis der P-Wellenamplitude zur maximalen P-Wellenamplitude zwischen 0,4 und 0,6 liegt, das Verhältnis der Spektralleistung zur maximalen Spektralleistung zwischen 0,4 und 0,6 liegt und die P-Wellenpolarität unipolar mit umgekehrter Polarität ist.
10. Einrichtung (100) nach Anspruch 4, wobei die endovaskuläre Vorrichtung (110) ein zentraler Venenkatheter ist, der mit einem Adapter (210) gekoppelt ist, der eine Elektrode in Kontakt mit einer Salzlösungssäule einschließt, die der Spitze des Katheters ausgesetzt ist, und das endovaskuläre EKG-Signal auf einem von der Elektrode gemessenen elektrischen Signal basiert.
11. Einrichtung (100) nach Anspruch 10, weiter umfassend Mittel zum Ausführen der folgenden Schritte:

gleichzeitig Empfangen eines Haut-EKG-Sig-

- nals, das einer Haut-EKG-Leitung (410; 420; 425; 430; 440; 460; 465; 470) zugeordnet ist, einschließlich eine Vielzahl von Wellenformen, wobei jede Wellenform mindestens eine P-Wellenkomponente aufweist;
- Verarbeiten des Haut-EKG-Signals über die Vielzahl von vorbestimmten Zeitdauern, um eine Haut-P-Wellenamplitude und eine Haut-Spektralleistung für jede vorbestimmte Zeitdauer zu berechnen;
- Bestimmen einer maximalen Haut-P-Wellenamplitude aus der Vielzahl von Haut-P-Wellenamplituden und einer zugeordneten maximalen Haut-Spektralleistung aus der Vielzahl von Haut-Spektralleistungen;
- Zuordnen der maximalen Haut-P-Wellenamplitude und der maximalen Haut-Spektralleistung zu der vorbestimmten Position im Herz oder in der Nähe des Herzens (400; 504; 604; 704); und Berechnen der Position der endovaskulären Vorrichtung (110) für jede vorbestimmte Zeitdauer basierend auf einem Verhältnis der endovaskulären P-Wellenamplitude zur maximalen Haut-P-Wellenamplitude und einem Verhältnis der endovaskulären Spektralleistung zur maximalen Haut-Spektralleistung.
12. Einrichtung (100) nach Anspruch 11, wobei die Position der endovaskulären Vorrichtung (110) die obere Hohlvene (A) ist, wenn das Verhältnis der endovaskulären P-Wellenamplitude zur maximalen Haut-P-Wellenamplitude zwischen 0,9 und 1,2 liegt, das Verhältnis der endovaskulären Spektralleistung zur maximalen Haut-Spektralleistung zwischen 0,9 und 1,2 liegt und die P-Wellenpolarität unipolar ist.
13. Einrichtung (100) nach Anspruch 12, wobei die Position der endovaskulären Vorrichtung (110) das untere Drittel der oberen Hohlvene ist, wenn das Verhältnis der endovaskulären P-Wellenamplitude zur maximalen Haut-P-Wellenamplitude zwischen 1,5 und 2,0 liegt, das Verhältnis der endovaskulären Spektralleistung zur maximalen Haut-Spektralleistung zwischen 1,5 und 2,0 liegt und die P-Wellenpolarität unipolar ist.
14. Einrichtung (100) nach Anspruch 13, wobei die Position der endovaskulären Vorrichtung (110) die Kaval-Atrial-Verbindung (C) ist, wenn das Verhältnis der endovaskulären P-Wellenamplitude zur maximalen Haut-P-Wellenamplitude größer als 2,5 ist, das Verhältnis der Spektralleistung zur maximalen Haut-Spektralleistung größer als 2,59 ist und die endovaskuläre P-Wellenamplitude größer als die endovaskuläre R-Wellenamplitude ist.
15. Einrichtung (100) nach Anspruch 14, wobei die Position der endovaskulären Vorrichtung (110) das rechte Atrium (D) ist, wenn das Verhältnis der endovaskulären Spektralleistung zur maximalen Haut-Spektralleistung zwischen 2,0 und 2,5 liegt und die endovaskuläre P-Wellenpolarität bipolar ist.
16. Einrichtung (100) nach Anspruch 15, wobei die Position der endovaskulären Vorrichtung (110) das obere Drittel der unteren Hohlvene ist, wenn das Verhältnis der endovaskulären P-Wellenamplitude zur maximalen Haut-P-Wellenamplitude zwischen 0,9 und 1,2 liegt, das Verhältnis der endovaskulären Spektralleistung zur maximalen Haut-Spektralleistung zwischen 0,9 und 1,2 liegt und die P-Wellenpolarität unipolar mit umgekehrter Polarität ist.
17. Einrichtung (100) nach Anspruch 1, wobei die P-Wellen ein P-Segment ist.
18. Computerbasierter Datenverarbeitungsalgorithmus zum Positionieren einer endovaskulären Vorrichtung (110) im Herz oder in der Nähe des Herzens (400; 504; 604; 704) unter Verwendung von Elektrokardiogramm-(EKG)-Signalen, wobei der computerbasierte Datenverarbeitungsalgorithmus, wenn er von einem Computer angewendet wird, den Computer veranlasst, die folgenden Schritte auszuführen:
- Empfangen eines endovaskulären EKG-Signals, das der endovaskulären Vorrichtung zugeordnet ist, einschließlich eine Vielzahl von Wellenformen, wobei jede Wellenform mindestens eine P-Wellenkomponente aufweist;
- dadurch gekennzeichnet, dass** der Datenverarbeitungsalgorithmus, wenn er von dem Computer angewendet wird, den Computer veranlasst, die folgenden Schritte auszuführen:
- Verarbeiten des endovaskulären EKG-Signals über eine Vielzahl von vorbestimmten Zeitdauern, um eine P-Wellenamplitude und eine Spektralleistung für jede vorbestimmte Zeitdauer zu berechnen;
- Bestimmen einer maximalen P-Wellenamplitude aus der Vielzahl von P-Wellenamplituden und einer zugeordneten maximalen Spektralleistung aus der Vielzahl von Spektralleistungen;
- Zuordnen der maximalen P-Wellenamplitude und der maximalen Spektralleistung zu einer vorbestimmten Position im Herz oder in der Nähe des Herzens;
- Berechnen einer Position der endovaskulären Vorrichtung für jede vorbestimmte Zeitdauer basierend auf einem Verhältnis der P-Wellenamplitude zur maximalen P-Wellenamplitude und einem Verhältnis der Spektralleistung zur maximalen Spektral-

leistung; und  
Anzeigen der Position der endovaskulären  
Vorrichtung an einen Benutzer.

19. Computerspeichermedium, das den computerbasierten Datenverarbeitungsalgorithmus nach Anspruch 18 darauf gespeichert hat.

### Revendications

1. Appareil (100) pour positionner un dispositif endovasculaire (110) dans ou près du coeur (400 ; 504 ; 604 ; 704) à l'aide de signaux d'électrocardiogramme (ECG), comprenant un module électronique (130 ; 250 ; 300) pour réaliser les étapes de :

réception d'un signal ECG endovasculaire, associé au dispositif endovasculaire, incluant une pluralité de formes d'onde, chaque forme d'onde ayant au moins une composante d'onde P ;

#### caractérisé en ce que

l'appareil comprend en outre un module d'ordinateur (140 ; 390) pour réaliser les étapes de :

traitement du signal ECG endovasculaire, sur une pluralité de périodes de temps prédéterminées, pour calculer une amplitude d'onde P et une puissance spectrale pour chaque période de temps prédéterminée ;  
détermination d'une amplitude d'onde P maximale à partir de la pluralité d'amplitudes d'onde P, et d'une puissance spectrale maximale associée à partir de la pluralité de puissances spectrales ;  
association de l'amplitude d'onde P maximale et de la puissance spectrale maximale à un emplacement prédéterminé dans ou près du coeur ;  
calcul d'un emplacement du dispositif endovasculaire, pour chaque période de temps prédéterminée, d'après un rapport entre l'amplitude d'onde P et l'amplitude d'onde P maximale et un rapport entre la puissance spectrale et la puissance spectrale maximale ; et  
affichage de l'emplacement du dispositif endovasculaire pour un utilisateur.

2. Appareil (100) selon la revendication 1, dans lequel l'amplitude d'onde P est une valeur de crête à crête, et l'amplitude d'onde P maximale est une valeur de crête à crête.
3. Appareil (100) selon la revendication 2, dans lequel ledit traitement du signal ECG inclut la détermination d'une polarité pour chaque amplitude d'onde P, et ledit calcul de l'emplacement du dispositif endovas-

culaire est également basé sur la polarité d'onde P pour chaque période de temps prédéterminée.

4. Appareil (100) selon la revendication 3, dans lequel l'emplacement prédéterminé est la jonction cavo-atriale (C).
5. Appareil (100) selon la revendication 4, dans lequel l'emplacement du dispositif endovasculaire (110) est la veine cave supérieure haute (A) si le rapport entre l'amplitude d'onde P et l'amplitude d'onde P maximale est inférieur à 0,4, le rapport entre la puissance spectrale et la puissance spectrale maximale est inférieur à 0,4, et la polarité d'onde P est unipolaire.
6. Appareil (100) selon la revendication 5, dans lequel l'emplacement du dispositif endovasculaire (110) est le tiers inférieur de la veine cave supérieure (B) si le rapport entre l'amplitude d'onde P et l'amplitude d'onde P maximale est entre 0,4 et 0,6, le rapport entre la puissance spectrale et la puissance spectrale maximale est entre 0,4 et 0,6, et la polarité d'onde P est unipolaire.
7. Appareil (100) selon la revendication 6, dans lequel l'emplacement du dispositif endovasculaire (110) est la jonction cavo-atriale (C) si le rapport entre l'amplitude d'onde P et l'amplitude d'onde P maximale est supérieur à 0,9, le rapport entre la puissance spectrale et la puissance spectrale maximale est supérieur à 0,9, et l'amplitude d'onde P est supérieure à l'amplitude d'onde R.
8. Appareil (100) selon la revendication 7, dans lequel l'emplacement du dispositif endovasculaire (110) est l'atrium droit (D) si le rapport entre la puissance spectrale et la puissance spectrale maximale est entre 0,6 et 0,9, et la polarité d'onde P est bipolaire.
9. Appareil (100) selon la revendication 8, dans lequel l'emplacement du dispositif endovasculaire (110) est le tiers supérieur de la veine cave inférieure si le rapport entre l'amplitude d'onde P et l'amplitude d'onde P maximale est entre 0,4 et 0,6, le rapport entre la puissance spectrale et la puissance spectrale maximale est entre 0,4 et 0,6, et la polarité d'onde P est unipolaire avec une polarité inversée.
10. Appareil (100) selon la revendication 4, dans lequel le dispositif endovasculaire (110) est un cathéter veineux central accouplé à un adaptateur (210) qui inclut une électrode en contact avec une colonne de solution saline exposée à l'extrémité du cathéter, et le signal ECG endovasculaire est basé sur un signal électrique mesuré par l'électrode.
11. Appareil (100) selon la revendication 10, comprenant en outre des moyens pour réaliser les étapes

de :

réception simultanée d'un signal ECG cutané, associé à une dérivation ECG cutanée (410 ; 420 ; 425 ; 430 ; 440 ; 460 ; 465 ; 470), incluant une pluralité de formes d'onde, chaque forme d'onde ayant au moins une composante d'onde P ;

traitement du signal ECG cutané, sur la pluralité de périodes de temps prédéterminées, pour calculer une amplitude d'onde P cutanée et une puissance spectrale cutanée pour chaque période de temps prédéterminée ;

détermination d'une amplitude d'onde P cutanée maximale à partir de la pluralité d'amplitudes d'onde P cutanées, et d'une puissance spectrale cutanée maximale à partir de la pluralité de puissances spectrales cutanées ; association de l'amplitude d'onde P cutanée maximale et de la puissance spectrale cutanée maximale à l'emplacement prédéterminé dans ou près du coeur (400 ; 504 ; 604 ; 704) ; et calcul de l'emplacement du dispositif endovasculaire (110), pour chaque période de temps prédéterminée, d'après un rapport entre l'amplitude d'onde P endovasculaire et l'amplitude d'onde P cutanée maximale et un rapport entre la puissance spectrale endovasculaire et la puissance spectrale cutanée maximale.

12. Appareil (100) selon la revendication 11, dans lequel l'emplacement du dispositif endovasculaire (110) est la veine cave supérieure haute (A) si le rapport entre l'amplitude d'onde P endovasculaire et l'amplitude d'onde P cutanée maximale est entre 0,9 et 1,2, le rapport entre la puissance spectrale endovasculaire et la puissance spectrale cutanée maximale est entre 0,9 et 1,2, et la polarité d'onde P est unipolaire.

13. Appareil (100) selon la revendication 12, dans lequel l'emplacement du dispositif endovasculaire (110) est le tiers inférieur de la veine cave supérieure si le rapport entre l'amplitude d'onde P endovasculaire et l'amplitude d'onde P cutanée maximale est entre 1,5 et 2,0, le rapport entre la puissance spectrale endovasculaire et la puissance spectrale cutanée maximale est entre 1,5 et 2,0, et la polarité d'onde P est unipolaire.

14. Appareil (100) selon la revendication 13, dans lequel l'emplacement du dispositif endovasculaire (110) est la jonction cavo-atriale (C) si le rapport entre l'amplitude d'onde P endovasculaire et l'amplitude d'onde P cutanée maximale est supérieur à 2,5, le rapport entre la puissance spectrale et la puissance spectrale maximale est supérieur à 2,59, et l'amplitude d'onde P endovasculaire est supérieure à l'amplitude d'onde R endovasculaire.

15. Appareil (100) selon la revendication 14, dans lequel l'emplacement du dispositif endovasculaire (110) est l'atrium droit (D) si le rapport entre la puissance spectrale endovasculaire et la puissance spectrale cutanée maximale est entre 2,0 et 2,5, et la polarité d'onde P endovasculaire est bipolaire.

16. Appareil (100) selon la revendication 15, dans lequel l'emplacement du dispositif endovasculaire (110) est le tiers supérieur de la veine cave inférieure si le rapport entre l'amplitude d'onde P endovasculaire et l'amplitude d'onde P cutanée maximale est entre 0,9 et 1,2, le rapport entre la puissance spectrale endovasculaire et la puissance spectrale cutanée maximale est entre 0,9 et 1,2, et la polarité d'onde P est unipolaire avec une polarité inversée.

17. Appareil (100) selon la revendication 1, dans lequel l'onde P est un segment P.

18. Algorithme de traitement de données par ordinateur pour positionner un dispositif endovasculaire (110) dans ou près du coeur (400 ; 504 ; 604 ; 704) à l'aide de signaux d'électrocardiogramme (ECG), l'algorithme de traitement de données par ordinateur, lorsqu'il est appliqué par un ordinateur, amène l'ordinateur à réaliser les étapes de :

réception d'un signal ECG endovasculaire, associé au dispositif endovasculaire, incluant une pluralité de formes d'onde, chaque forme d'onde ayant au moins une composante d'onde P ; **caractérisé en ce que** l'algorithme de traitement de données, lorsqu'il est appliqué par ordinateur, amène l'ordinateur à réaliser les étapes de :

traitement du signal ECG endovasculaire, sur une pluralité de périodes de temps prédéterminées, pour calculer une amplitude d'onde P et une puissance spectrale pour chaque période de temps prédéterminée ; détermination d'une amplitude d'onde P maximale à partir de la pluralité d'amplitudes d'onde P, et d'une puissance spectrale maximale associée à partir de la pluralité de puissances spectrales ; association de l'amplitude d'onde P maximale et de la puissance spectrale maximale à un emplacement prédéterminé dans ou près du coeur ; calcul d'un emplacement du dispositif endovasculaire, pour chaque période de temps prédéterminée, d'après un rapport entre l'amplitude d'onde P et l'amplitude d'onde P maximale et un rapport entre la puissance spectrale et la puissance spectrale maximale ; et

affichage de l'emplacement du dispositif endovasculaire pour un utilisateur.

19. Support de stockage par ordinateur sur lequel est stocké l'algorithme de traitement de données par ordinateur selon la revendication 18. 5

10

15

20

25

30

35

40

45

50

55

18

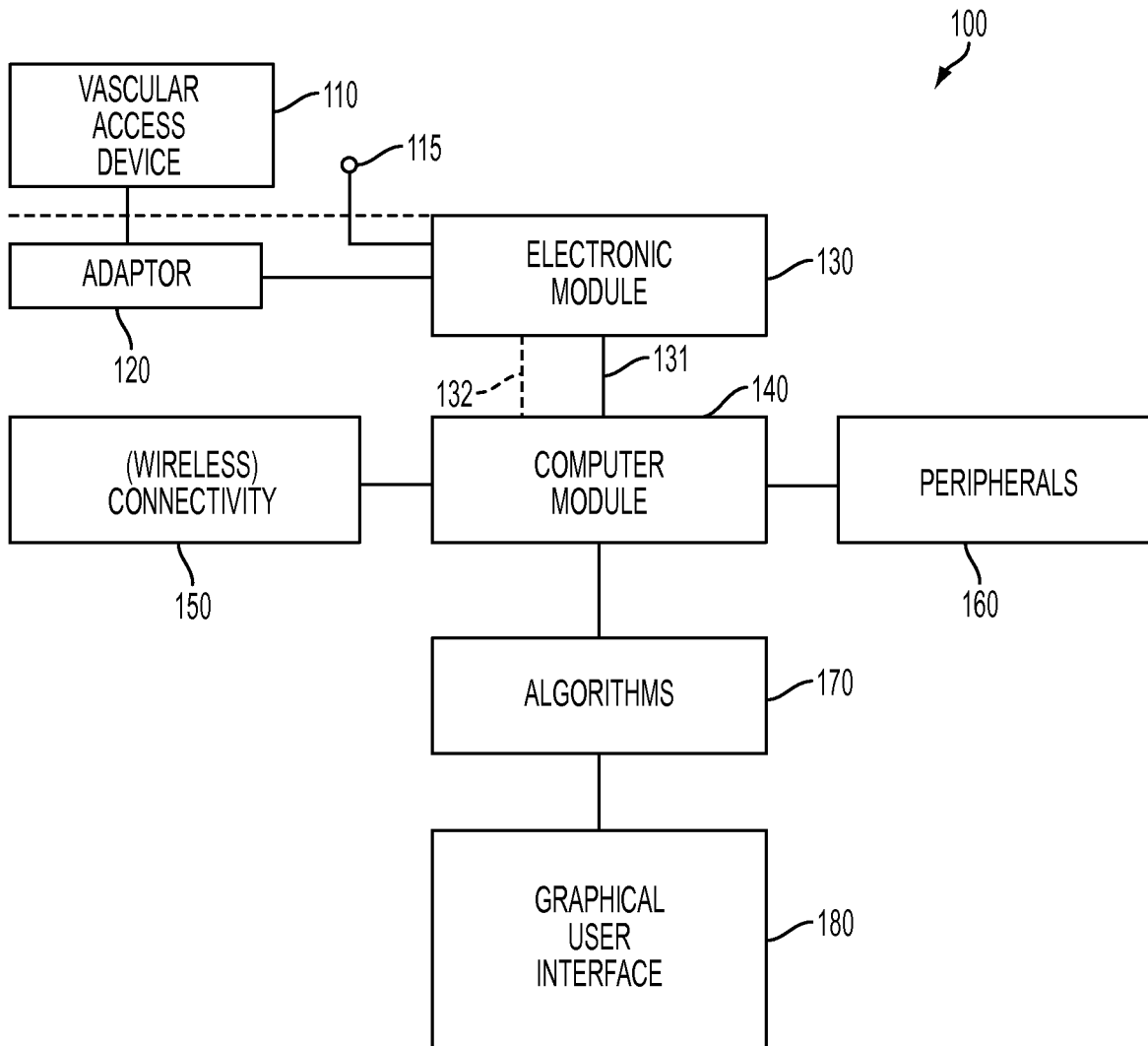

FIG. 1

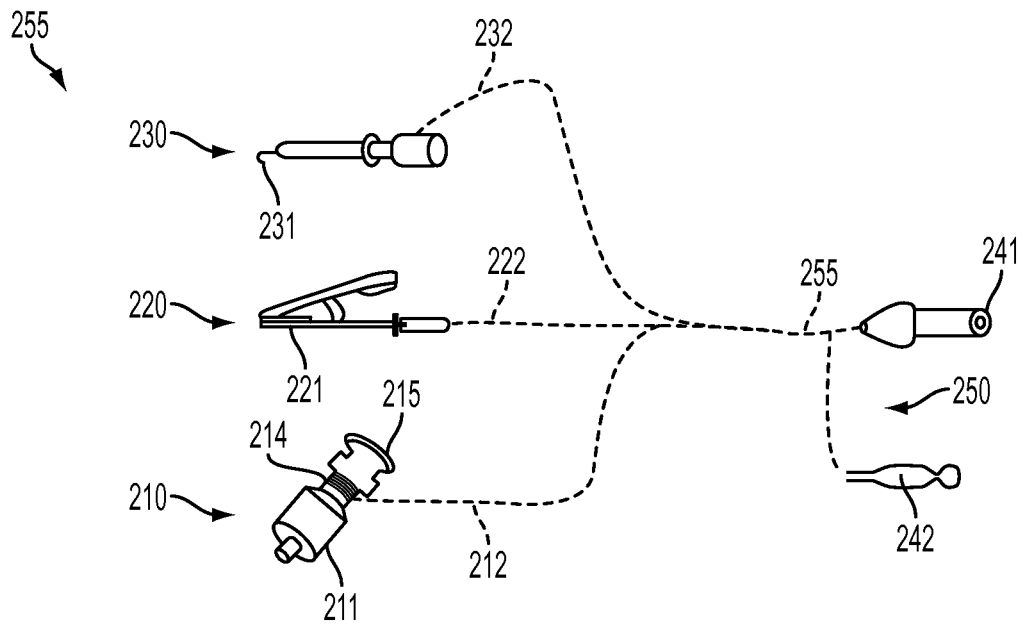

FIG. 2A

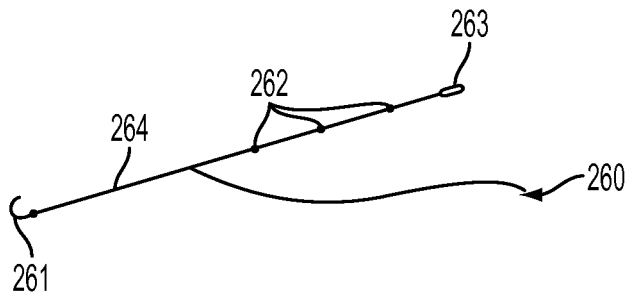

FIG. 2B

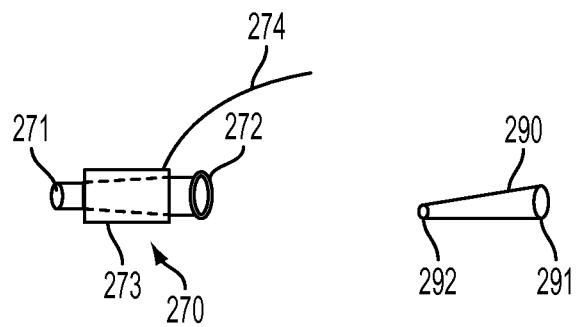

FIG. 2C

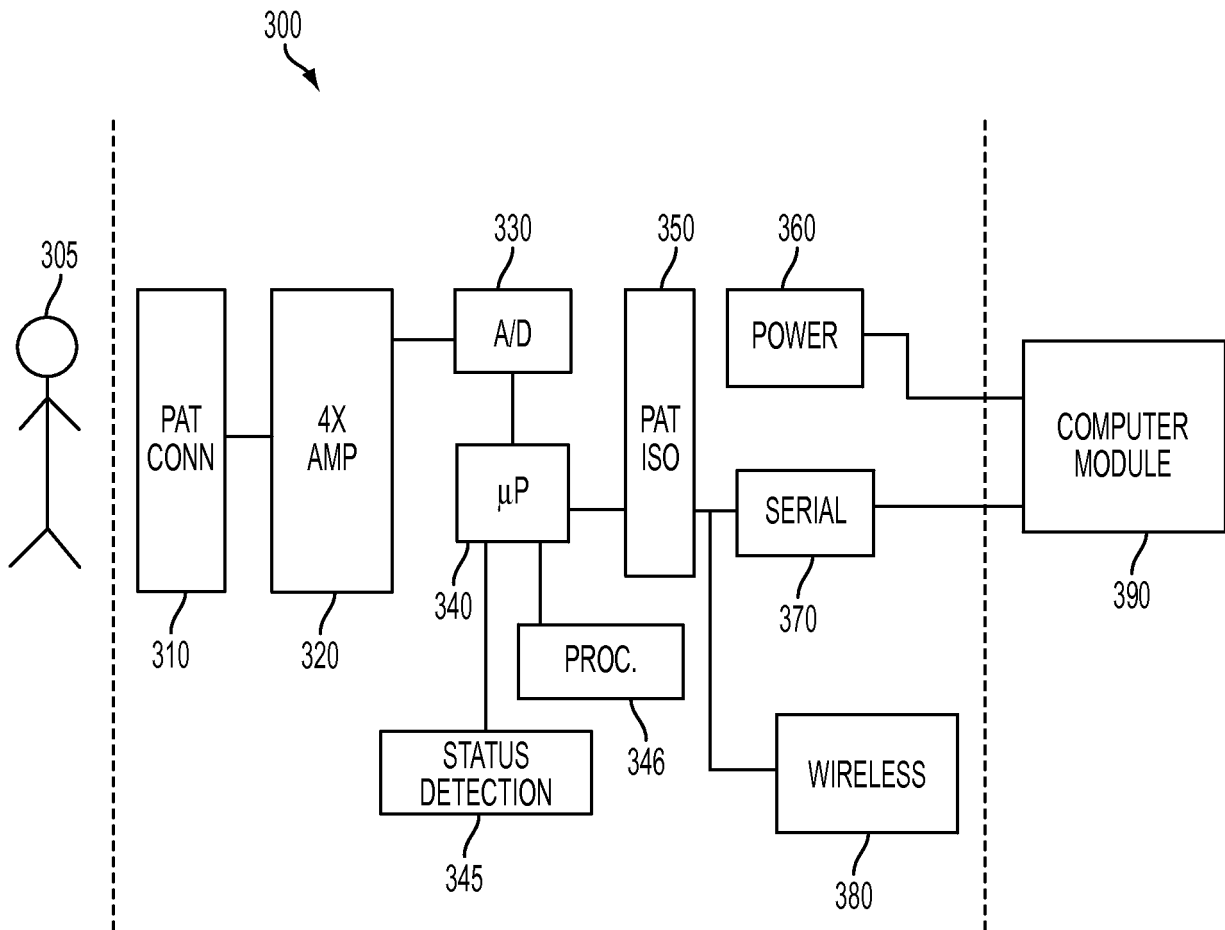

FIG. 3

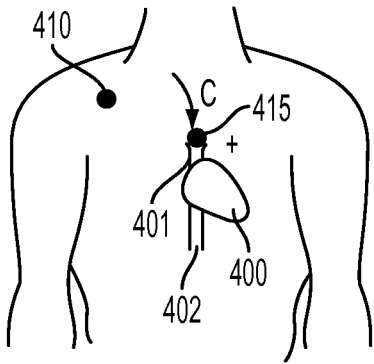

FIG. 4A

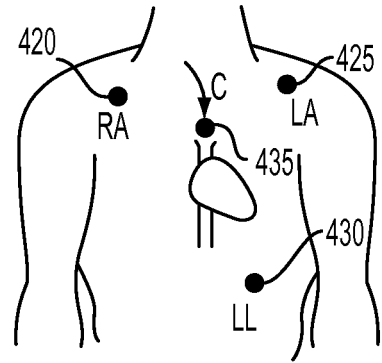

FIG. 4B

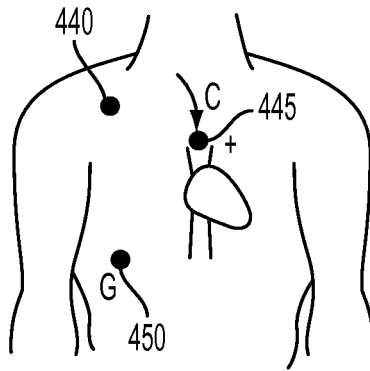

FIG. 4C

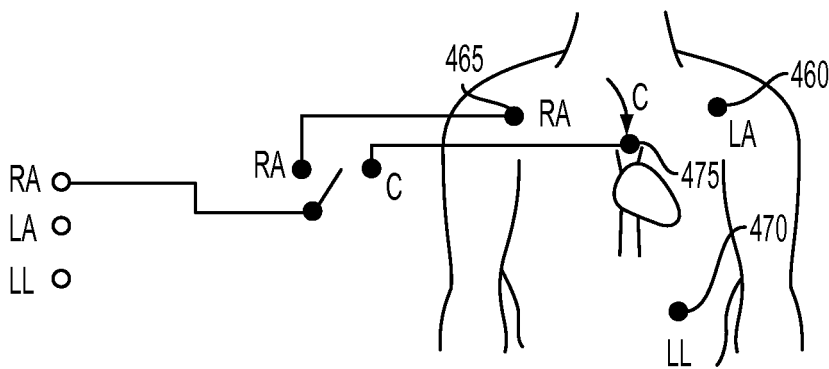

FIG. 4D

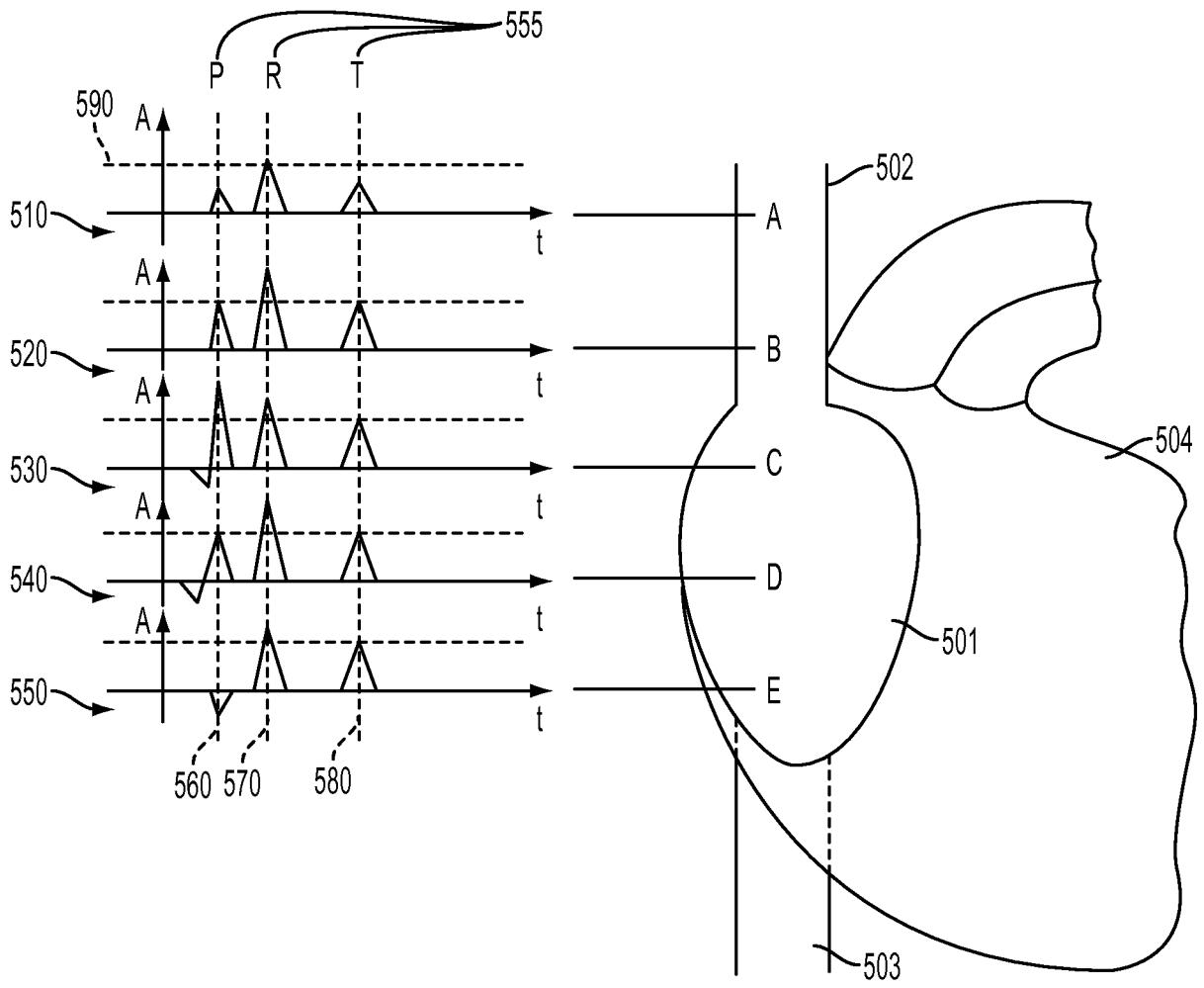

FIG. 5

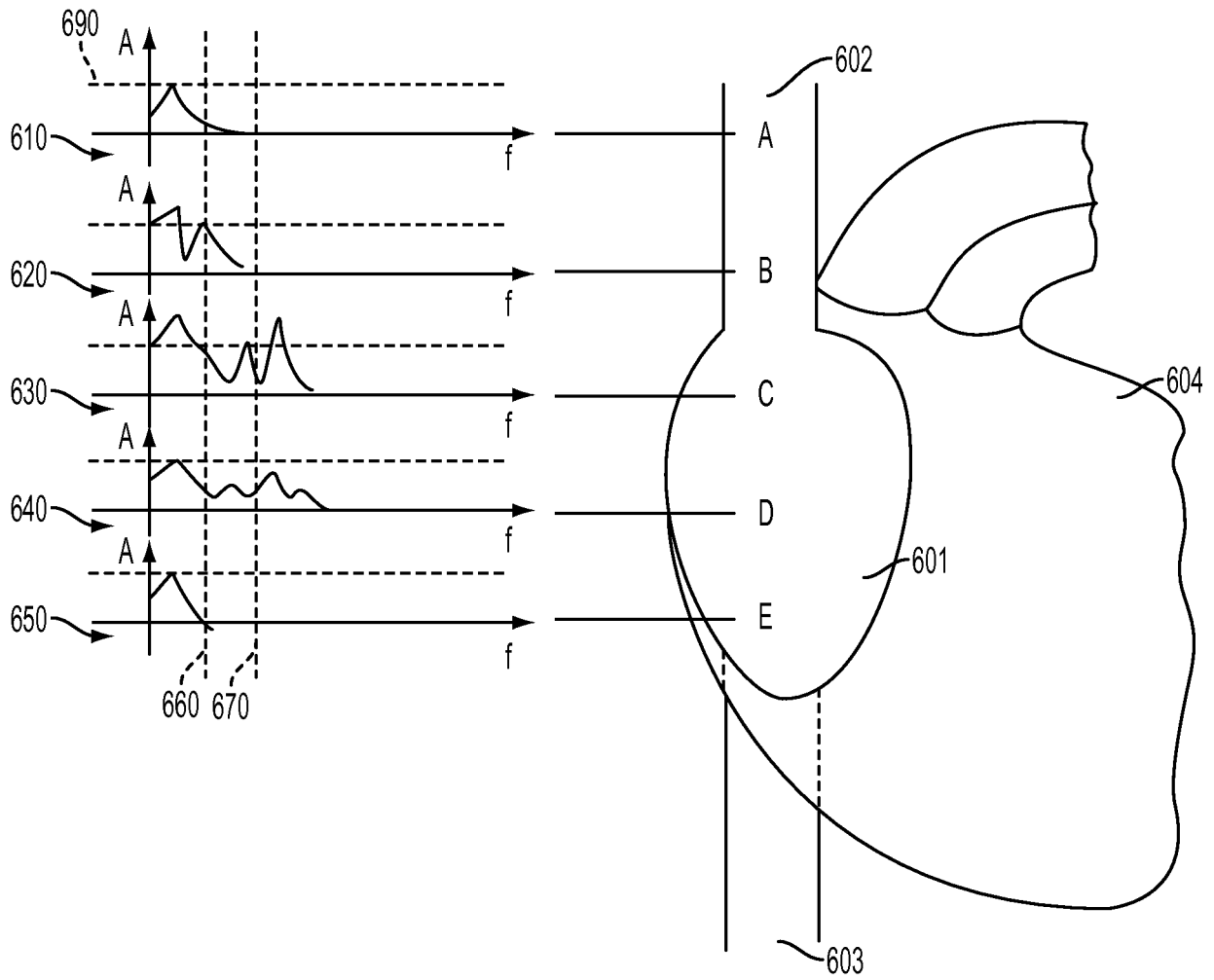

FIG. 6

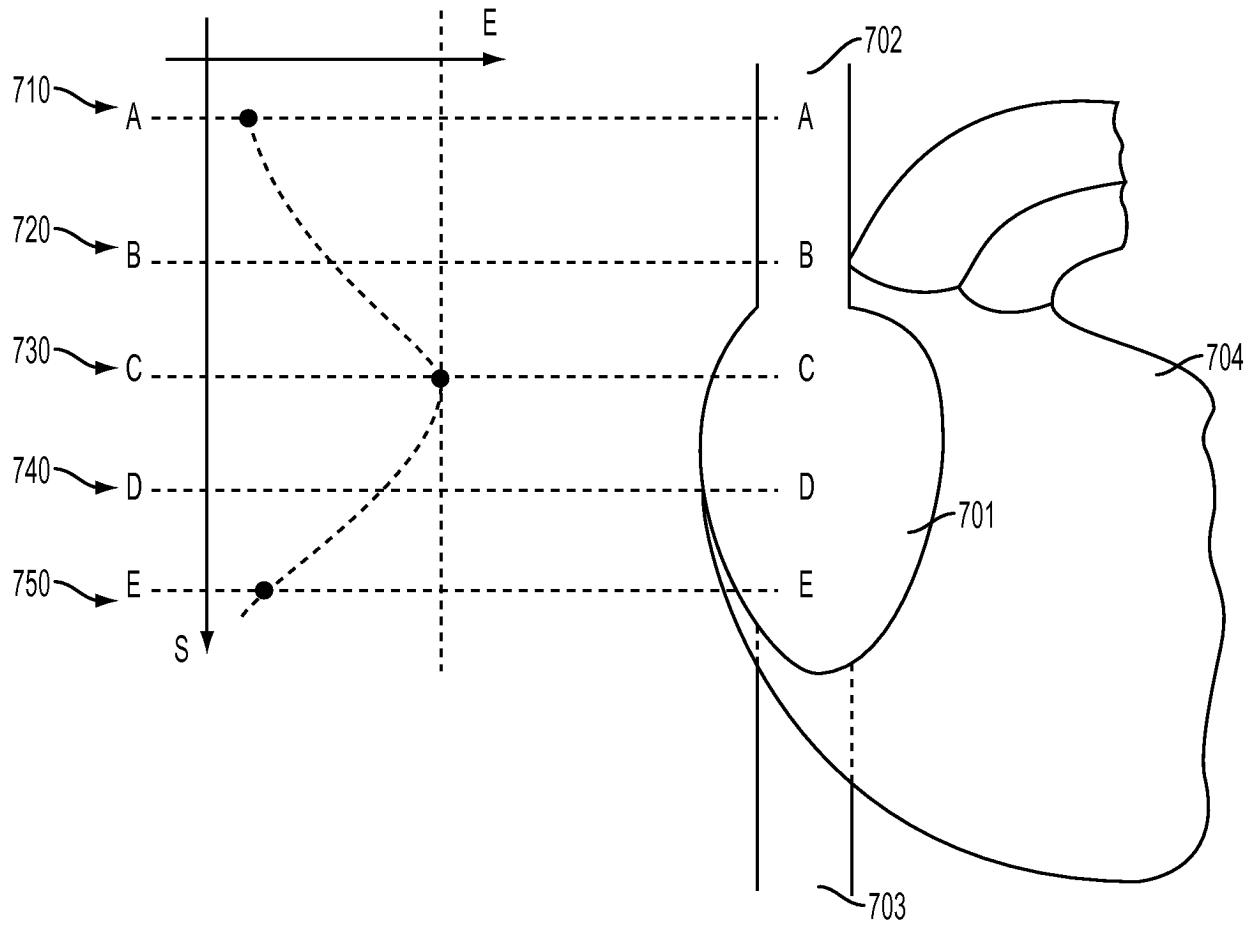

FIG. 7

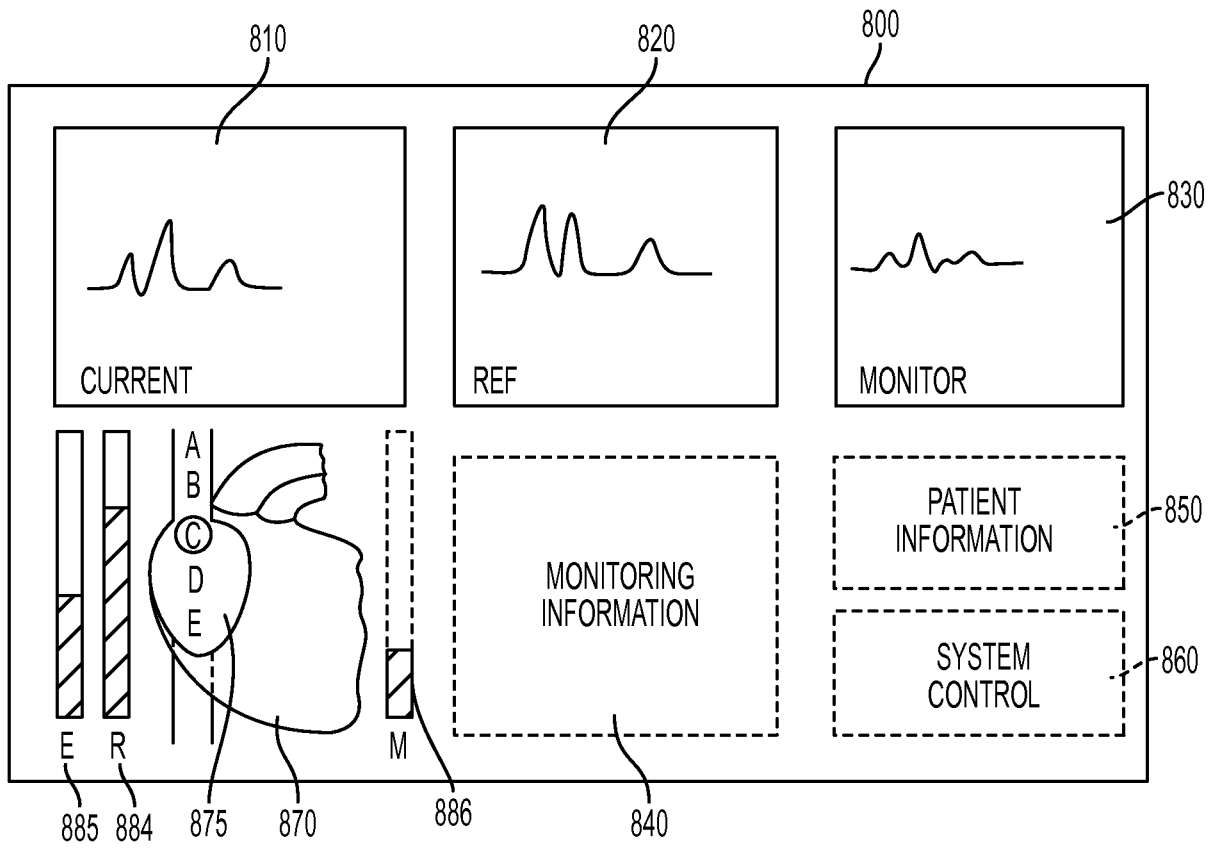

FIG. 8

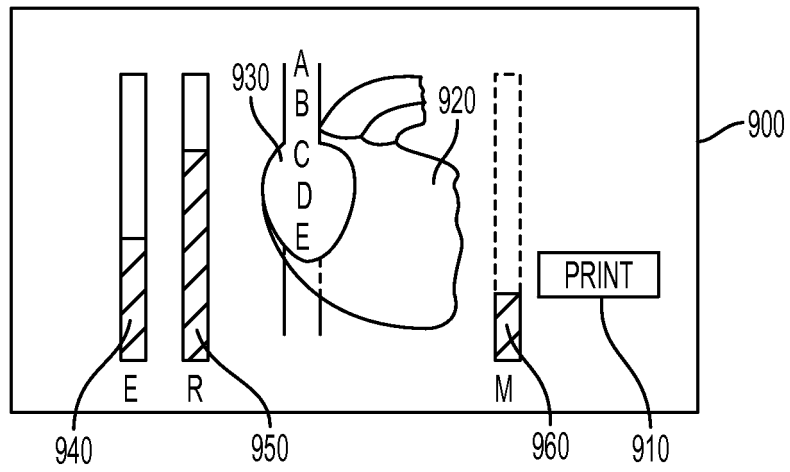

FIG. 9

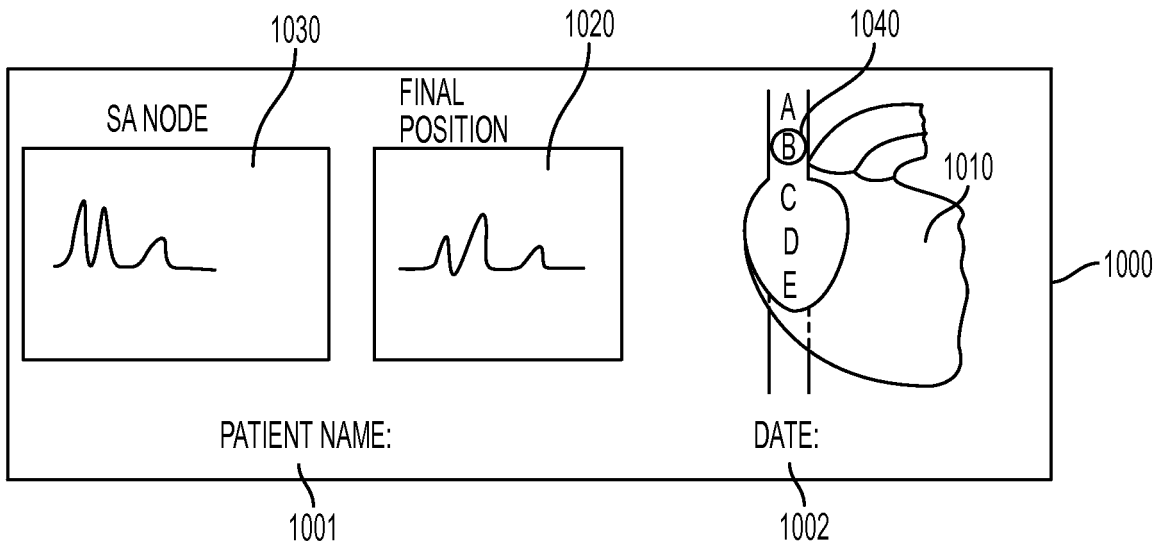

FIG. 10A

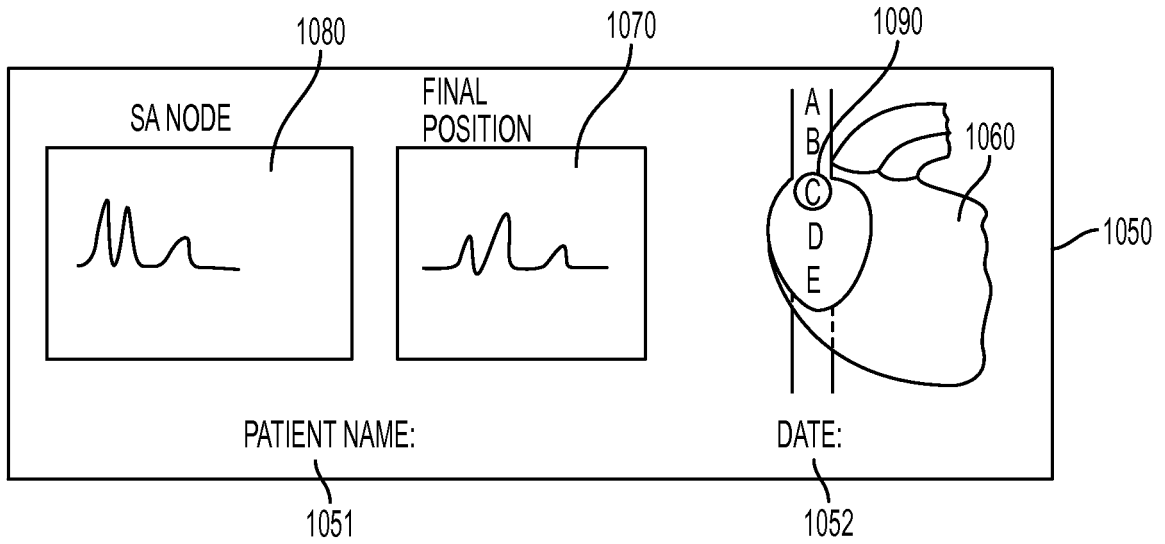

FIG. 10B

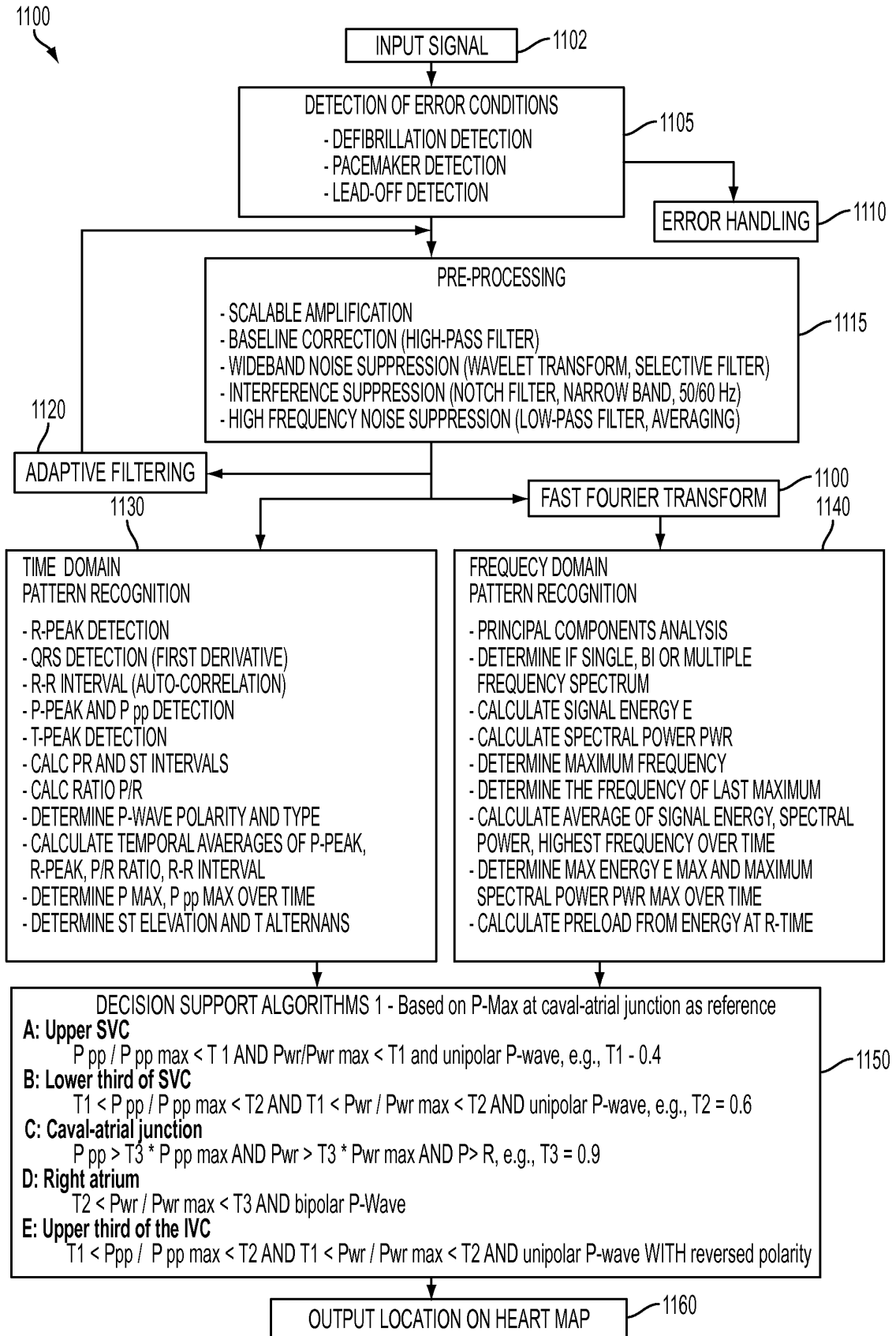

FIG. 11

1250

DECISION SUPPORT ALGORITHMS 1 - Based on skin ECG as reference

**A: Upper SVC**  
 $T1 < P_{pp} / P_{pp\ skin} < T2$  AND  $T1 < P_{wr} / P_{wr\ skin} < T2$  and unipolar P-wave, e.g.,  $T1 = 0.9, T2 = 1.2$

**B: Lower third of SVC**  
 $T3 < P_{pp} / P_{pp\ skin} < T4$  AND  $T3 < P_{wr} / P_{wr\ skin} < T4$  AND unipolar P-wave, e.g.,  $T3 = 1.5, T4 = 2$

**C: Caval-atrial junction**  
 $P_{pp} > T5 * P_{pp\ skin}$  AND  $P_{wr} > T5 * P_{wr\ skin}$  AND  $P > R$ , e.g.,  $T5 = 2.5$

**D: Right atrium**  
 $T6 < P_{wr} / P_{wr\ skin} < T7$  AND bipolar P-wave, e.g.,  $T6 = 2, T7 = 2.5$

**E: Upper third of the IVC**  
 $T1 < P_{pp} / P_{pp\ skin} < T2$  AND  $T1 < P_{wr} / P_{wr\ skin} < T2$  AND unipolar P-wave WITH reversed polarity

**FIG. 12**

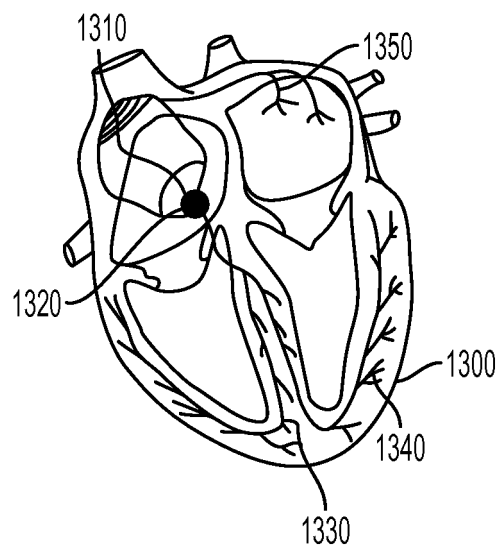

FIG. 13

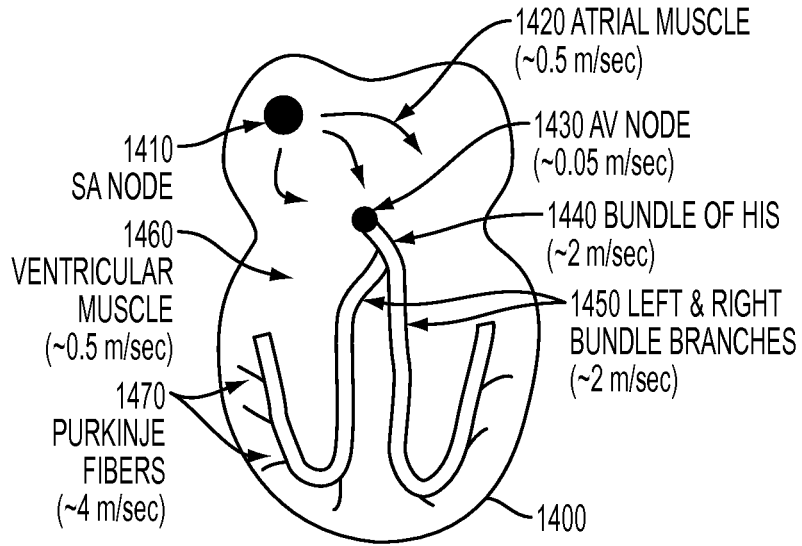

FIG. 14

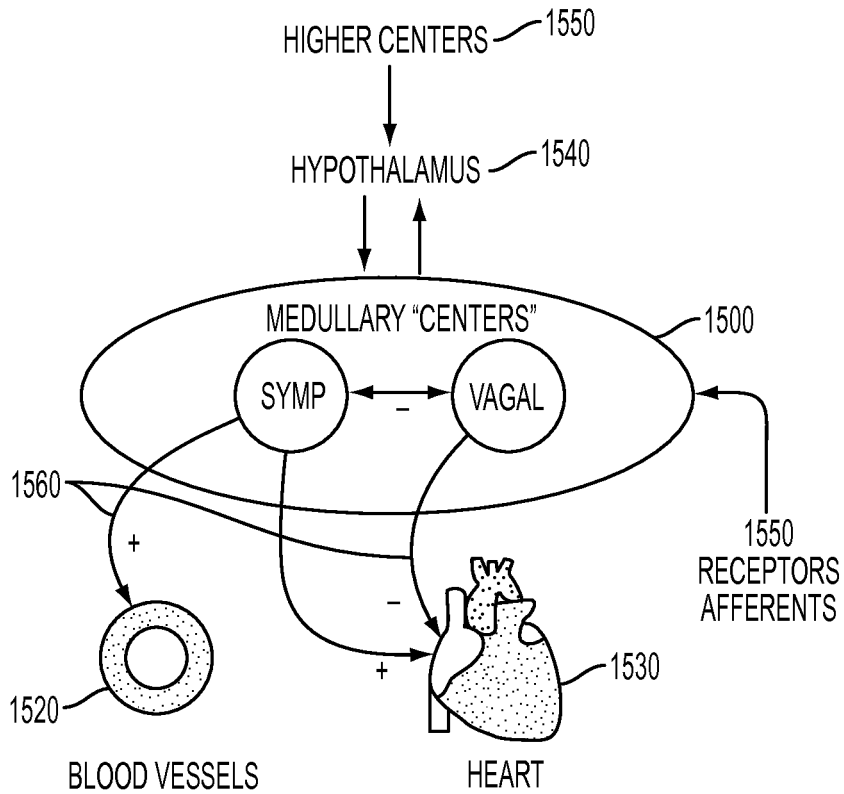

FIG. 15

**REFERENCES CITED IN THE DESCRIPTION**

*This list of references cited by the applicant is for the reader's convenience only. It does not form part of the European patent document. Even though great care has been taken in compiling the references, errors or omissions cannot be excluded and the EPO disclaims all liability in this regard.*

**Patent documents cited in the description**

- US 5121750 A [0009]
- US 20070299352 A1 [0010]
- WO 2004002303 A1 [0011]

专利名称(译)	导管尖端定位方法		
公开(公告)号	<a href="#">EP2440122A1</a>	公开(公告)日	2012-04-18
申请号	EP2010786978	申请日	2010-06-14
[标]申请(专利权)人(译)	巴德阿克塞斯系统股份有限公司		
申请(专利权)人(译)	BARD接入系统, INC.		
当前申请(专利权)人(译)	BARD接入系统, INC.		
[标]发明人	GRUNWALD SORIN		
发明人	GRUNWALD, SORIN		
IPC分类号	A61B5/02 A61B5/00		
CPC分类号	A61B5/04017 A61B5/042 A61B5/0452 A61B5/06 A61B5/065 A61B5/726 A61B34/20 A61B5/046 A61B5/0468 A61M25/0105 A61M25/0014 A61M2039/1077 A61M2039/1083 A61M2039/1088		
优先权	61/213474 2009-06-12 US		
其他公开文献	EP2440122A4 EP2440122B1		
外部链接	<a href="#">Espacenet</a>		

#### 摘要(译)

一种用于血管内心电图的适配器，包括：具有第一端，第二端和内腔的构件，所述第一端可连接至导管的鲁尔接头，所述第二端可连接至注射器，以使来自所述注射器的流体为通过内腔冲入导管；沿着构件的内腔布置并位于构件内部的金属插入件，特别是金属环，该金属环通过密封的电连接连接到构件的外侧。一种用于血管内心电图的组件，包括：适配器；与连接器的构件分开的连接器联接到金属环。