



(51) International Patent Classification:

A61N 1/372 (2006.01) A61N 1/18 (2006.01)
A61B 5/00 (2006.01) A61N 1/36 (2006.01)
A61N 1/04 (2006.01)

(21) International Application Number:

PCT/US2018/044858

(22) International Filing Date:

01 August 2018 (01.08.2018)

(25) Filing Language:

English

(26) Publication Language:

English

(30) Priority Data:

62/542,741 08 August 2017 (08.08.2017) US

(71) Applicant: EBR SYSTEMS, INC. [US/US]; 686 W. Maude Avenue, Suite 102, Sunnyvale, California 95132 (US).

(72) Inventor: WILLIS, N. Parker; 98 Reservoir Road, Atherton, California 94027 (US).

(74) Agent: CHAN, Darby; Wilson Sonsini Goodrich and Rosati, 650 Page Mill Road, Palo Alto, California 94304 (US).

(81) Designated States (unless otherwise indicated, for every kind of national protection available): AE, AG, AL, AM, AO, AT, AU, AZ, BA, BB, BG, BH, BN, BR, BW, BY, BZ, CA, CH, CL, CN, CO, CR, CU, CZ, DE, DJ, DK, DM, DO, DZ, EC, EE, EG, ES, FI, GB, GD, GE, GH, GM, GT, HN, HR, HU, ID, IL, IN, IR, IS, JO, JP, KE, KG, KH, KN, KP, KR, KW, KZ, LA, LC, LK, LR, LS, LU, LY, MA, MD, ME, MG, MK, MN, MW, MX, MY, MZ, NA, NG, NI, NO, NZ, OM, PA, PE, PG, PH, PL, PT, QA, RO, RS, RU, RW, SA, SC, SD, SE, SG, SK, SL, SM, ST, SV, SY, TH, TJ, TM, TN, TR, TT, TZ, UA, UG, US, UZ, VC, VN, ZA, ZM, ZW.

(84) Designated States (unless otherwise indicated, for every kind of regional protection available): ARIPO (BW, GH, GM, KE, LR, LS, MW, MZ, NA, RW, SD, SL, ST, SZ, TZ, UG, ZM, ZW), Eurasian (AM, AZ, BY, KG, KZ, RU, TJ, TM), European (AL, AT, BE, BG, CH, CY, CZ, DE, DK, EE, ES, FI, FR, GB, GR, HR, HU, IE, IS, IT, LT, LU, LV, MC, MK, MT, NL, NO, PL, PT, RO, RS, SE, SI, SK, SM,

(54) Title: SYSTEMS, DEVICES, AND METHODS FOR ELECTROMECHANICAL SENSING AND MAPPING

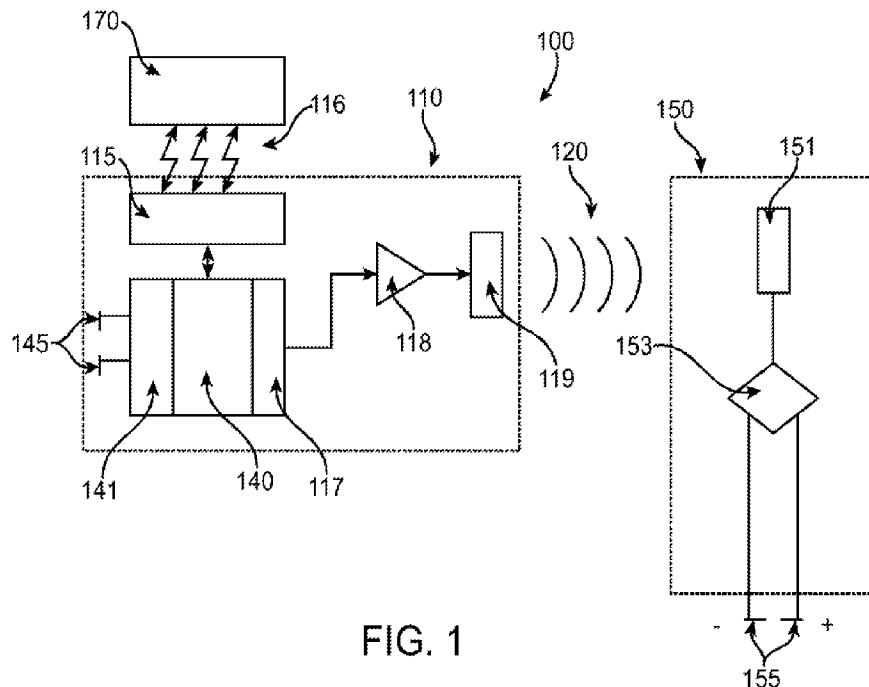

FIG. 1

(57) Abstract: Systems, devices, and methods for tracking and determining the motion of a cardiac implant is disclosed. The motion of the implant is determined by transmitting acoustic energy to a tissue location using an acoustic controller-transmitter comprising an array of acoustic transducers; wherein the implant is configured to convert the transmitted acoustic energy to electrical energy; and the tracking is achieved by determining the electrical energy delivered to the tissue throughout one or more cardiac cycles in order to create a motion profile of the cardiac implant.



TR), OAPI (BF, BJ, CF, CG, CI, CM, GA, GN, GQ, GW,
KM, ML, MR, NE, SN, TD, TG).

Declarations under Rule 4.17:

- *as to applicant's entitlement to apply for and be granted a patent (Rule 4.17(ii))*
- *as to the applicant's entitlement to claim the priority of the earlier application (Rule 4.17(iii))*

Published:

- *with international search report (Art. 21(3))*

SYSTEMS, DEVICES, AND METHODS FOR ELECTROMECHANICAL SENSING AND MAPPING

CROSS-REFERENCES TO RELATED APPLICATION

[0001] This application claims the benefit and priority of U.S. Provisional Application No. 62/542,741, entitled “SYSTEMS, DEVICES, AND METHODS FOR ELECTROMECHANICAL SENSING AND MAPPING”, filed on August 8, 2017, the full disclosure of the above referenced application is incorporated herein by reference.

BACKGROUND OF THE INVENTION

[0002] The systems, devices, and methods of this disclosure relates to electromechanical mapping and sensing the motion of the heart and other body organs and tissues by means of one or more implantable devices.

[0003] A single cycle of cardiac activity may be divided into the diastole phase and the systole phase. The diastole phase is a period of time when the ventricles are relaxed and not contracting. Throughout most of this period, blood is flowing from the left atrium (LA) and right atrium (RA) into the left ventricle (LV) and right ventricle (RV). The systole phase is a period during which the left and right ventricles contract and eject blood into the aorta and pulmonary artery, respectively. During the systole phase, the aortic and pulmonic valves open to permit ejection into the aorta and pulmonary artery. The atrioventricular valves are closed during systole, therefore no blood is entering the ventricles. However, blood continues to enter the atria through the vena cavae and pulmonary veins.

[0004] Furthermore, changes in aortic pressure (AP), left ventricular pressure (LVP), left atrial pressure (LAP), left ventricular volume (LV Vol), and heart sounds during a single cycle of cardiac contraction and relaxation may be related in time to the electrocardiogram.

[0005] Mechanical motion data from various imaging modalities, e.g. MRI and echocardiography may be used in cardiac resynchronization therapy (CRT). In some cases, algorithms may be applied to MRI data to predict the best pacing location as the site that is the most mechanically delayed. Investigators have also used various motion metrics primarily based on echo strain studies to determine the effectiveness of CRT therapy.

[0006] Thus it would be desirable to construct a mechanical motion profile and to utilize the mechanical motion profile to determine the pacing time window and/or pacing location.

BRIEF SUMMARY OF THE INVENTION

[0007] The embodiments herein describe aspects of devices, systems, and methods that are configured to track the location of an implantable receiver-stimulator in the heart relative to the controller-transmitter to produce a 3D motion sensing or mapping of the receiver-stimulator. In one aspect, an electrical location signal generated by the receiver-stimulator is used to locate the receiver-stimulator. By applying the location signal tracking continuously throughout one or more cardiac cycles, one aspect of the system is configured to dynamically track the 3D motion of the receiver-stimulator to create a motion profile. In another aspect, optionally, the 3D motion of the receiver-stimulator could be combined with the EKG data wherein the EKG data may be used to normalize the motion profile. In yet another aspect, the 3D motion of the receiver-stimulator may be correlated with EGM data obtain at a one or more locations of the heart to provide a electromechanical motion profile of a tissue region, such as a potential implant site.

[0008] In one embodiment, the system is configured to utilize the electromechanical mapping data to determine the general locations of the receiver-stimulator at the end of diastole (ventricles full of blood) and/or the end of systole (ventricles emptied). In one aspect, the system is configured to trigger pacing upon the determination of the electrode location at the end diastolic position. In another aspect, the system is configured to deliver the pacing pulse immediately or delayed by a fixed time amount. In yet another aspect, the delivery of the pacing pulse could be contingent on the receiver-stimulator remaining in the end diastolic location for a fixed time period. Detection of a departure from the end diastolic location of the electrode would inhibit pacing. Lack of motion from end-diastolic location for a fixed duration would imply that the ventricles are fully relaxed, filled with blood, therefore it is appropriate to deliver a pacing pulse. In another aspect, the system may be configured to initiate the stimulation prior to the end of diastolic position such that the system accounts for the electro-mechanical delay of the pacing pulse.

[0009] This and other aspects of the present disclosure are described herein.

BRIEF DESCRIPTION OF DRAWNGS

[0010] Present embodiments have other advantages and features which will be more readily apparent from the following detailed description and the appended claims, when taken in conjunction with the accompanying drawings, in which:

[0011] FIG. 1 is a block diagram illustrating a tissue stimulation system.

[0012] FIGS. 2A-B illustrate one embodiment of this invention.

[0013] FIG. 3 illustrates the acoustic array scanning a region for location signals in response to locator signals.

[0014] FIG. 4 illustrates sensor data where the acoustic beam is directed at the receiver-stimulator of the right ventricle.

[0015] FIG. 5 illustrates sensor data where the acoustic beam is directed at the receiver-stimulator of the left ventricle.

[0016] FIG. 6 illustrates a high sample rate EKG in parallel with a typical low bandwidth EKG.

[0017] FIGS. 7A-B illustrate the cardiac cycle are shown indicating systole and diastole in relation to the electrical stimulation and motion tracking.

[0018] FIG. 8A-D illustrate sensor data during continuous sensing the receiver-stimulator position.

[0019] FIG. 9 A-B shows a comparison of sensor data with fluoroscopic images.

[0020] FIGS. 10 A-C shows an example of abnormal hemodynamics from premature LV pacing detectable by the receiver-stimulator motion.

DETAILED DESCRIPTION OF THE INVENTION

[0021] While the invention has been disclosed with reference to certain embodiments, it will be understood by those skilled in the art that various changes may be made and equivalents may be substituted without departing from the scope of the invention. In addition, many modifications may be made to adapt to a particular situation or material to the teachings of the invention without departing from its scope.

[0022] Throughout the specification and claims, the following terms take the meanings explicitly associated herein unless the context clearly dictates otherwise. The meaning of “a”, “an”, and “the” include plural references. The meaning of “in” includes “in” and “on.” Referring to the drawings, like numbers indicate like parts throughout the views. Additionally, a reference to the singular includes a reference to the plural unless otherwise stated or inconsistent with the disclosure herein.

[0023] The word “exemplary” is used herein to mean “serving as an example, instance, or illustration.” Any implementation described herein as “exemplary” is not necessarily to be construed as advantageous over other implementations.

[0024] Various embodiments are described herein with reference to the figures. The figures are not drawn to scale and are only intended to facilitate the description of the embodiments.

They are not intended as an exhaustive description of the invention or as a limitation on the scope of the invention. In addition, an illustrated embodiment needs not have all the aspects or advantages shown. An aspect or an advantage described in conjunction with a particular embodiment is not necessarily limited to that embodiment and may be practiced in any other embodiments even if not so illustrated.

[0025] Systems, devices, and methods to provide electromechanical motion sensing and/or mapping of the heart are disclosed. In one aspect, the motion and/or mapping data is used to optimize the timing and location for tissue stimulation. More specifically, aspects of systems, devices, and methods for motion sensing and mapping the local physiological values, sensing the motion, and/or the shape of the heart to determine the activation profile of the heart and, preferably, to analyze the resulting maps to determine possible optimizations in the activation profile for stimulation of the tissue.

[0026] In one embodiment, the system comprises a first implanted device, generally referred to as the controller-transmitter or acoustic controller-transmitter, which provides appropriate timing and control functions and transmits acoustic energy to a second implanted device. The second implanted device, generally referred to as the receiver-stimulator, receives the acoustic energy and converts it into electrical energy and applies that electrical energy to electrodes. The second device is adapted to be permanently implanted at a location where it is desired to provide electrical stimulus, with at least one electrode in direct contact with the cardiac muscle or other body tissue. Optionally, two or more receiver-stimulators may be implanted to be controlled by a single controller-transmitter.

[0027] In one aspect, the system is configured to track the location of one or more of the receiver-stimulators relative to the acoustic source such as the controller-transmitter to sense the motion and to produce a motion profile. In another aspect, wherein the receiver-stimulator is implanted or otherwise connected to the heart. In one aspect, an electrical location signal generated by the receiver-stimulator is used to locate the receiver-stimulator. In an embodiment, the receiver-stimulator generates the electrical location signal in response to receiving acoustic energy from the controller-generator. By applying the location signal tracking periodically or continuously throughout one or more cardiac cycles, one aspect of the system is configured to dynamically track the 3D motion of the receiver-stimulator to create a motion profile of the receiver-stimulator. In another aspect, the 3D motion of the receiver-stimulator could be combined with the EGM data to provide complete electromechanical mapping data of a tissue region, such as a potential implant site.

[0028] In one embodiment, the system is configured to utilize the mechanical motion data to determine the general locations of the receiver-stimulator at any point of the diastolic or systolic phases and in particular at the end of diastole (ventricles full of blood) and/or the end of systole (ventricles emptied). In one aspect, the mechanical motion data may be first normalized with EKG data to establish locations of the receiver-stimulator during systole and diastole. In one embodiment, the system may learn the time it takes to fill from end systole to end diastole. The system may then use the learned fill time to as a reference to determine the appropriate timing for pacing. In one embodiment, after the initial normalization, no further EKG data are used and the motion of the heart is established with the sensed mechanical motion data. In another embodiment, EKG data may be continuously applied to calibrate the mechanical motion data. In various embodiments, EKG data may be collected using surface EKG electrodes. Additionally or alternatively, EKG data may be collected using sensing electrodes mounted on the controller-transmitter or the delivery system.

[0029] In one aspect, the system is configured to trigger pacing upon the determination of the electrode at the end diastolic position. In another aspect, once the mechanical motion data is established, the system may be configured to deliver the pacing pulse to optimize energy delivery. In one aspect, immediately or delayed by a fixed time amount. In yet another aspect, the delivery of the pacing pulse could be contingent on the receiver-stimulator remaining in the end diastolic location for a fixed time period. Detection of a departure from the end diastolic location of the electrode would inhibit pacing. Lack of motion from end-diastolic location for a fixed duration would imply that the ventricles are fully relaxed, filled with blood, therefore it is appropriate to deliver a pacing pulse. In yet another aspect, the delivery of the pacing pulse may be contingent on the receiver-stimulator being in a desired location within the systolic-diastolic motion cycle thus anticipating the end of diastole to synchronize the pacing pace to an optimum point in the electro-mechanical cycle. In an embodiment, the system is configured to initiate the stimulation prior to the end of diastolic position such that the system accounts for the electro-mechanical delay of the pacing pulse.

[0030] In another aspect, the mechanical motion data of the receiver-stimulator may be correlated with EGM data and/or electrogram characteristics to create an electromechanical motion profile. In one embodiment, the electromechanical motion profile may be utilized to determine an abnormal activation profile due to a conduction abnormality, such as a block, for assessing the effects of tachycardia or for assessing changes in the activation profile as a function of heart rate. In yet another embodiment, the 3D motion of the receiver-stimulator alone, or correlated with geometrical characteristics of the heart or with EGM data or

electrogram characteristics may be utilized to compare the local activation time to the movement of a segment of the heart. For example, the activation time of the segment to movement of the segment relative to the movement of surrounding segments.

[0031] For example, the mechanical motion data, alone or in combination with additional data may be used to determine the geometry and/or changes in the geometry of at least a portion of the heart as a function of time and/or phase of the cardiac cycle. For example, the existence of a ventricular dyssynchrony or electrical-mechanical dissociation may be determined from characteristics during systole. Likewise, a dilated ventricle may be determined from the determined volume.

[0032] In one embodiment, the system is configured to track the location of the receiver-stimulator relative to the controller-transmitter over one or more cardiac cycle by using a location signal and/or a locator signal as disclosed in U.S. App. No. 14/221,040, herein incorporated by reference. It should be noted that the location signal tracking embodiments as described are just examples of how to determine the 3D motion of the receiver-stimulator to establish a motion profile of the tissue area.

[0033] More specifically, in one embodiment, the system is configured to use an array of acoustic transducers of the controller-transmitter to transmit acoustic energy at a specific location in the body. The acoustic receiver of the receiver-stimulator is configured to generate an electric location signal via one or more electrodes, whenever it receives acoustic energy. Separate detection electrodes may detect the electric location signal indicating when the array of acoustic transducers is focused on the acoustic receiver and revealing the location of the receiver. The transducer array could be configured to sequentially steer the acoustic energy until the location signal is detected or a preset time limit has been reached. The location signal could be detected by a sensing circuit on the controller-transmitter.

[0034] In another embodiment of the invention, the controller-transmitter would be further configured to adjust the transducer array to transmit focused acoustic energy to the region of the tissue associated with detecting the location signal. This focused energy could be adequate to stimulate tissue and, in particular, cardiac tissue. In yet another embodiment, this focused energy would be generated based on characteristics of the location signal.

[0035] In yet another embodiment of this invention, an implantable acoustic controller-transmitter comprises an adjustable transducer array configured to transmit acoustic energy into tissue; an implantable acoustic receiver-stimulator comprises a transducer assembly adapted to receive the acoustic energy and convert the acoustic energy to electrical energy, where the transmitter is configured to transmit an acoustic locator signal towards the receiver,

and the receiver is configured to generate a location signal. Optionally, the location signal could be either an electrical output or an acoustic transmission in response to the locator signal.

[0036] Referring now to FIG. 1, where one embodiment of a leadless tissue stimulation system is shown as system **100**. An implantable or external controller-transmitter module **110** generates acoustic waves **120** of sufficient amplitude and frequency and for a duration and period such that the receiver-stimulator module **150** electrically stimulates tissue. An external programmer **170** wirelessly communicates with an implantable controller-transmitter module **110**, typically by radio frequency telemetry means **116**, to adjust operating parameters. The implantable controller-transmitter module **110** comprises a telemetry receiver **115** for adjusting the transmit acoustic characteristics, control circuitry **140** and signal generator **117**, a power amplifier **118**, and an output transducer assembly **119** for generating the acoustic beam **120** transmitted to receiver-stimulator **150**. Understandably, the controller-transmitter **110** transfers acoustic energy to the receiver-stimulator **150** leadlessly. Control circuitry **140** contains an electrical signal sensing circuit element **141** connected to one or more sensing electrodes **145** disposed on the outer casing of the controller-transmitter or connected via cables to the controller-transmitter. Alternatively, electrical sensing circuit **141** may be a typical electrogram sensing circuit or may be an electrical spike detection circuit. Additionally, controller-transmitter **110** may be configured to collect and process EKG data collected using sensing electrodes **145**.

[0037] The receiver-stimulator **150** comprises a piezoelectric receiving transducer **151**, rectifier circuitry **153**, and at least one tissue contacting electrode **155**. In this embodiment, acoustic energy received and rectified by the receiver-stimulator is directly applied to the electrodes **155**. Alternatively, the receiver-stimulator module **150** may comprise multiple transducer/rectifier channels in a variety of combinations, which may be in series or parallel orientations, or the construction may perform impedance matching, and/or for signal filtering to increase the efficiency of the receiver-stimulator, as disclosed in co-pending U.S. App. No. 11/315,524, herein incorporated by reference.

[0038] Referring now to FIG. 2A, where one embodiment of the present invention is shown as system **200**. The controller-transmitter module **210** is placed either inside the body, but remote from myocardial tissue, or outside the body in contact with the body surface. The external programmer **170** communicates with the controller-transmitter module **210**, typically by radio frequency telemetry **116**. The telemetry module **115** inside the controller-transmitter unit **210** provides two-way communications directly with the control circuitry **220**. A

separate continuous wave (CW) signal generator **217** inside the controller-transmitter **210** provides the acoustic operating frequency for the system.

[0039] The control circuitry **220** and signal generator **217** are both connected to each channel of a two dimensional acoustic transducer array **260** (shown in FIG. 2B), where each channel comprises a transmit/receive transducer element **230 ij**, a power amplifier **218 ij** and phase shifter module **240 ij**. The phase shifter module **240 ij**, ensures that during acoustic transmissions, each channel transmits with the correct phase so as to form an efficient, focused narrow acoustic beam intended to precisely intercept the receiver-stimulator. A control signal from control circuitry **220** defines the transmit phases. The output of the phase shifter **240 ij** then passes to the power amplifier **218 ij** of the channel, which is also under the control of the control circuitry **220**, and which may be either in an OFF state, a full ON state, or at selected levels of intermediate power which might be required for beam shading. The output of the power amplifier passes directly to the channel transducer element **230 ij**. One embodiment of using the phase shifter for each output channel has been described above. Other techniques may also be employed, such as direct formatting of the transmit beam by the control circuitry **220**.

[0040] The controller-transmitter **210** would scan a spatial region by sending narrow acoustic beams (the locator signals), looking for a response (the location signal), from the receiver-stimulator. If the focused, directed acoustic beam intersects the receiver-stimulator the acoustic energy is converted by the receiver-stimulator and delivered as an electrical output onto the electrodes **155**. This electrical output would generate an electrical signal that would be detected by sensing electrodes **145** and detection circuits **241** of the controller-transmitter **210**. If the controller-transmitter **210** does not detect an electrical signal within a reasonable time frame, the inference would be that the directed acoustic beam did not intersect the receiver-stimulator and the directed acoustic beam was “off target.” Such time frames may be predetermined or determined based on location signal characteristics. Then, the controller-transmitter **210** adjusts the focused, directed beam to another portion of the region where the receiver-stimulator **150** may be located, possibly chosen to be close to the previous region, and repeat the locator signal transmission thereby scanning the spatial region iteratively. In this manner, an electrical signal is generated and detected if the receiver-stimulator **150** is in the spatial region being scanned. The controller-transmitter **210** then uses the focused, directed beam parameters that resulted in a detected electrical signal (location signal) as the target (transmission region) for the efficient transmission of a narrow acoustic beam of acoustic energy towards the receiver-stimulator. Alternatively, the controller-

transmitter **210** could then analyze characteristics of the detected electrical signal to determine whether the directed transmitter beam was adequately targeting the receiver-stimulator **150**.

[0041] The scanning process is shown in more detail in FIG. 3. The phased array **260** of the controller-transmitter **210** is composed of individual transducers **230 ij**. For convenience the array is oriented in the x-y plane at $z=0$. The spatial volume to be scanned **305** encompasses all of the possible locations for the receiver-stimulator **150**, and, again for convenience, is located in the $z>0$ half space with respect to the phased array **260**. The extent of **305** is constrained by anatomical limits and may vary depending on the specific stimulation application. The spatial volume **305** is broken up into multiple volumes **302 kl**, which are individually scanned or tested. The volumes **302 kl** may overlap; however, it is desirable to have the entire collection of volumes cover the region **305**. The array is aimed at a volume **302 kl** by setting the appropriate phase parameters for the array elements **230 ij**.

[0042] In one aspect, the embodiments described above may be applied continuously or periodically throughout one or more cardiac cycles to dynamically track the location of the receiver-stimulator as the mechanical motion of the heart through the cardiac cycles affects the location of the receiver-stimulator and thereby achieve 3D motion tracking of the receiver-stimulator to construct a motion profile of the receiver-stimulator. In one embodiment, the motion of the heart is determined relative to the movements of the receiver-stimulator. In another embodiment, where more than one receiver-stimulators are tracked, a map of the heart relative to the movement of the receiver-stimulators is created.

[0043] In another aspect, the 3D motion data may be captured during pacing or stimulation of the tissue. Clearly the 3D motion of the receiver-stimulator when pacing captures will be different from when it does not. Not only will the 3D motion vary, more importantly and more easily detected, the onset of the 3D motion relative to the application of the pacing pulse will change. In one aspect, the motion timing difference between the pacing state versus the non-pacing state could be used to reliably detect capture at the receiver-stimulator.

[0044] In one embodiment, the devices, systems, and methods of the present embodiments further comprises at least one computing element with at least one processing element and memory element to process the 3D motion data. In one embodiment, the computing element is configured to correlate the motion data with additional data such as geometrical characteristics of the heart, EGM data and/or electrogram characteristics such as another cardiac reference including but not limited to a co-implant.

[0045] In one embodiment, several metrics could be applied to assess a tissue region via the motion data of the receiver-stimulator, including, but not limited to: A) mechanical delay during intrinsic conduction or during right ventricular pacing; B) change/reduction in mechanical delay as a result of left ventricular pacing vs. intrinsic conduction or right ventricular pacing; C) the overall magnitude of the cardiac motion; D) volume data; and/or other characteristics of the tissue region.

[0046] In yet another aspect of the present embodiments, a receiver-stimulator is configured to be implantable in the right ventricle and/or the left ventricle endocardially and/or epicardially. In one aspect, a controller-transmitter configured to be implantable subcutaneously, exemplarily, in one embodiment, the controller-transmitter is configured to be implantable subcutaneously in the intercostal space. As previously discussed, the controller-transmitter is configured to deliver acoustic energy and the receiver-stimulator is configured to convert the acoustic energy to electrical energy where the electrical energy is delivered to the tissue to cause electrical stimulation, such as pacing stimulation.

[0047] It is noted that aspects of the present embodiments may be applied in a co-implanted configuration where the controller-transmitter and the receiver-stimulator are both implanted in the body as described above. It is also noted that aspects of the present embodiment may be applied where one or more receiver-stimulators are implanted to a tissue region or temporarily connected to the tissue region, a temporary electrical connection, such as via a delivery system may be used to determine the EGM generated by the stimulation of heart tissue is monitored using one or more temporary electrode connections on the receiver-stimulator or other electrodes, e.g., surface EKG electrodes or other electrodes mounted on the delivery system.

[0048] The temporary electrical connection may also be used to determine the efficiency of conversion of energy to electrical stimulation energy by the receiver-stimulator at a given location in the heart. In one embodiment, this is accomplished by delivering acoustic energy from a wireless controller-transmitter or similar implantable or externally-applied acoustic transmitter to the wireless receiver-stimulator, converting the acoustic energy to electrical energy, and delivering electrical energy to the heart tissue through the receiver-stimulator's cathode and an anode, while monitoring the electrical energy using an external monitor connected to the electrodes via the temporary electrical connections through the delivery system. The electrical energy in this embodiment need not be at pacing strength, since conversion efficiency may be gauged even at lower energy levels.

[0049] As described in the co-pending US. Pat. App. No. 15/043,210 incorporated herein by reference, a delivery system may be configured to provide signal interconnect with an external monitor and pacing controller to facilitate location selection during an implant procedure by collecting local EGM data, performing direct electrical pacing of the heart via electrical connections to one or more of the electrodes of the receiver-stimulator device, and evaluating operational efficiency of the receiver-stimulator.

[0050] In one aspect, where EGM data may be collected, such as via a temporary electrical connection, the location of the implanted receiver-stimulator could be tracked over the course of a cardiac cycle to create a mechanical motion profile. In one aspect, EGM data is configured to be simultaneously or periodically recorded. By combining the EGM data with the mechanical motion profile to determine the general locations of the receiver-stimulator at the end diastole (ventricles full of blood), the end systole (ventricles emptied), or both. In one embodiment, the controller-transmitter is configured to trigger pacing via determination of the receiver-stimulator at the end diastolic position. In one embodiment, delivery of the pacing pulse could be immediate or delayed by a fixed time amount. In yet another embodiment, delivery of the pacing pulse could be contingent on the receiver-stimulator remaining in the end diastolic location for a fixed time period. In yet another embodiment, detection of a departure from the end diastolic location of the receiver-stimulator would inhibit pacing. Lack of motion from end-diastolic location for a fixed duration would imply that the ventricles are fully relaxed, filled with blood, therefore it is appropriate to deliver a pacing pulse.

[0051] In one aspect, the determination of the location of the receiver-stimulator may be accomplished by periodic acoustic transmission at the same location say every 1-200ms. In some aspects, continuous tracking of the receiver-stimulator location may be performed every 1-100 ms rather than directing the spotlight to a single transmit angle. In some aspects, the system, method and device are configured to track hemodynamic loss or loss of motion due to rapid pacing based on the receiver-stimulator motion. If the receiver-stimulator moves out of this location as determined by the lack of or a decreased in electrical output as elicited by acoustic transmission, then the acoustic transmission may be adjusted to re-locate the receiver-stimulator. In one aspect, if the receiver-stimulator remains in the same location for more than a fixed programmable time interval representing a low rate limit of electrical output then deliver an electrical output as a pacing pulse. In this sense the system functions as a brady pacemaker. If the receiver-stimulator does not move after the application of the pacing pulse, then it may be conclude that the patient is in a hemodynamically unstable

rhythm and an Antitachycardia pacing protocol would be applied. If there was no motion after the Antitachycardia pacing then a defibrillation shock would be delivered. This scheme could also be used in conjunction with EGM monitoring however the potential advantage of hemodynamic monitoring is that it is much faster than electrical detection used in ICDs which requires analysis of multiple beats to detect either VT or VF. A simple hemodynamic sensor has the advantage of rapid intervention at the onset of the arrhythmia which could make the Antitachycardia pacing more effective. In some aspects, the system, method and device are configured to detect electrical-mechanical dissociation or pulseless electrical activity based on EGM data and the location of one or more receiver-stimulators. For example, if organized electrical activity is detected along with a lack of or decreased motion of one or more receiver stimulators, then the system may conclude that the patient is in a state of electrical-mechanical dissociation.

[0052] In an embodiment, the system is configured to trigger pacing based on EKG data collected using sensing electrodes mounted on the controller-transmitter. In one aspect, the system initiates pacing upon detection of the initiation of QRS. Delivery of the pacing pulse could be immediate or delayed by a fixed time amount.

[0053] In various embodiments, the system may use one or more receiver-stimulators for tissue capture and pacing along with one or more additional receiver-stimulators or non-stimulating receivers for heart wall motion detection. As an example, one or more receiver-stimulators may be placed at clinically optimal pacing locations which may not necessarily correspond to the location of greatest motion potential, such as the bundle of His.

Additionally, one or more receiver-stimulators may be anchored at locations with large motion, such as the lateral wall. In this way the system would achieve both optimum pacing potential and optimum motion detection. In one embodiment, the receiver used for motion detection could have the same design as the receiver-stimulator used for tissue capture. In another embodiment, the receiver used for motion detection could have a modified design since it would not be required to provide tissue capture. For example, the motion detection receiver could be smaller, have a different shape, use fewer transducers, rectifiers, or other components, or have a different electrode configuration. In one aspect the electrode of the motion detection receiver could be at the tip of an anchoring needle. In other aspects, the electrode of the motion detection receiver could be at a location configured to just touch the heart wall or on the body of the receiver.

EXAMPLES

[0054] Experimental data were gathered in a dual site experimental model implanted with two receiver-stimulators: one in the left ventricle and one in the right ventricle. Using the Test2 Command, a manufacturing test command that performs repeated transmit query pulses to a fixed target location and stores the resulting query response amplitudes which may be read back through a base station radio. The controller-transmitter delivered acoustic energy to the last known location of a given receiver-stimulator. This essentially created a pulsed acoustic “spotlight” directed at the last known location of the receiver-stimulator. It was expected to observe a periodic waveform indicating the motion of the receiver-stimulator over time as it repeatedly left the spotlight beam and then returned back to a spatial point sometime around the onset of QRS. All of this testing was performed in normal sinus rhythm.

[0055] The initial experiment directed the beam at the receiver-stimulator of the right ventricle position from several minutes in the past. One hundred points were recorded over approximately one second and the result is as shown in FIG. 4.

[0056] As seen in FIG. 4, there is a clear and rapid drop in QSD amplitude after the peak at approximately 1000uV. Assuming that the receiver-stimulator position is correct, it may be concluded that this is due to ventricular contraction, whereas the rise in QSD amplitude is due to ventricular filling during end diastole.

[0057] A similar test targeting the last known location for the receiver-stimulator of the left ventricle. The results for a five second are shown FIG. 5.

[0058] As seen in FIG. 5, the variability in peak amplitude was likely due to respiratory variability. There is also a clear periodic variability in the time-of-flight (TOF). Variability in the right ventricle TOF was due to low amplitude QSD noise detection.

[0059] Furthermore, the QSD “spot-light” waveform correlate with cardiac electrical activation by recording a high sample rate EKG in parallel with a typical low bandwidth EKG during these experiments, as shown in FIG. 6.

[0060] As seen in FIG. 6, there are clearly two additional spikes, most likely from the co-implant device. The device was in an AOO mode (there is no actual OFF mode) with the telemetry wand in place. It is likely that these were telemetry artifacts that are aligned with V, which is likely due to far field sensing of the A wave by atrial lead of the co-implant device. It may be confirmed that from the surface EKG that the high amplitude portion of the QSD waveform is associated with a full ventricle. This confirms that the last known location of the

receiver-stimulator used as the direction for the “spot-light” illumination is still reasonably accurate.

[0061] Referring now to FIGs. 7A-7B, where a graphical representation of the cardiac cycle is shown indicating systole and diastole. It is noted that the time of the peak QSD response is associated with both the end of diastole and beginning of systole. This is because the region that was targeted with the “spot-light” is associated with the receiver-stimulator position when the ventricle is full. Therefore, the QSD waveform when targeted to the QRS phase of the EKG is correlated to the left ventricle volume.

[0062] Alternatively if the “spot-light” at a phase of the cardiac cycle corresponding to an empty ventricle (end systole or early diastole, between the T and P waves), the resulting QSD waveform would be 180 degrees shifted in phase, with minimum points corresponding to a full ventricle.

[0063] In another example, continuous tracking of the receiver-stimulator location was performed every 10 ms rather than directing the spotlight to a single transmit angle. FIGs. 8A-D illustrate the receiver-stimulator position (angle and depth) as a function of cardiac cycle phase. The receiver-stimulator position shows excellent detail of the heart wall motion over the cardiac cycle, as shown in FIG. 8A, and matches well with previously published data of ventricular volume. Further, respiration is clearly evident from the data as shown in FIG. 8B-C illustrating the response amplitude from a QSD sensor overlaid with the receiver-stimulator angle. The EKG data collected from the controller-transmitter sensing electrodes show both QRS and T-waves, as shown in FIG. 8D. FIGs. 9A-9B show a comparison of controller-transmitter sensor data (FIG. 9A) with fluoroscopic images (FIG. 9B). Heart wall motion over the cardiac cycle as determined by the controller-transmitter sensor data matches with heart wall motion observed in the fluoroscopic images.

[0064] FIG 10 A-C shows an example of abnormal hemodynamics from premature LV pacing detectable by the receiver-stimulator motion. FIG. 10A shows EKG data collected using surface EKG electrodes. The hemodynamic loss or loss of motion due to rapid pacing which was not clear from electrical inputs (FIG. 10B) was clearly visible based on the receiver-stimulator motion (FIG. 10C).

[0065] Although particular embodiments have been shown and described, they are not intended to limit the invention. Various changes and modifications may be made to any of the embodiments, without departing from the spirit and scope of the invention. The invention is intended to cover alternatives, modifications, and equivalents.

WHAT IS CLAIMED IS:

1. A system for tissue stimulation, comprising:
an implantable acoustic controller-transmitter comprising an array of acoustic transducers configured to transmit acoustic energy to a cardiac tissue location; and
at least one implantable acoustic receiver adapted to receive acoustic energy and convert the acoustic energy into electrical energy that is delivered to the tissue;
wherein movement of the acoustic receiver is tracked by measuring the delivered electrical energy to create a motion profile of the acoustic receiver relative to the tissue.
2. The system of claim 1, wherein the tissue is cardiac tissue and the system is configured to determine a location of the receiver during the cardiac cycle.
3. The system of claim 2, wherein the system is configured to map the cardiac motion by tracking the location of the receiver through one or more cardiac cycle.
4. The system of claim 3, wherein the system is configured to determine a position of the receiver at the end of diastole.
5. The system of claim 4, wherein the controller-transmitter is configured to deliver sufficient acoustic energy to trigger pacing stimulation based on a determination that the receiver is located at the end diastolic position.
6. A method of tissue stimulation, comprising:
transmitting acoustic energy to a cardiac tissue location using an implantable acoustic controller-transmitter comprising an array of acoustic transducers;
converting the transmitted acoustic energy to electrical energy using one or more acoustic receiver-converter;
delivering the electrical energy to the cardiac tissue;
tracking the location of the receiver-converter throughout one or more cardiac cycles; and
creating a motion profile of the receiver-converter.
7. The method of claim 6, further comprising transmitting sufficient acoustic energy by the controller-transmitter based on the location of the receiver-converter to trigger a pacing electrical energy to be delivered to the cardiac tissue by the receiver-converter.
8. The method of claim 6, further comprising normalizing the motion profile with EKG data.

9. The method of claim 6, further comprising correlating the motion profile with EGM data to create a electromechanical motion profile.
10. A system for tracking the motion of an implantable cardiac device, comprising:
 - an implantable acoustic controller-transmitter comprising an array of acoustic transducers configured to transmit acoustic energy to a cardiac tissue location; and
 - at least one implantable acoustic receiver adapted to receive acoustic energy and convert the acoustic energy into electrical energy;wherein the system is configured to detect the electrical energy throughout one or more cardiac cycles to dynamically track the 3D motion data of the implantable acoustic receiver.
11. The system of claim 10, wherein the implantable acoustic receiver comprising two electrodes configured to be in electrical connection with tissue and to deliver the electrical energy to the tissue; the acoustic receiver further comprises two electrodes configured to be in electrical connection with tissue and to deliver the electrical energy to the cardiac tissue.
12. The system of claim 10, wherein the controller-transmitter further comprising comprises a sensing circuit and a sensing electrode assembly configured to be in electrical connection with the body, wherein the delivered electrical energy is detected by the sensing circuit.
13. The system of claim 10, wherein the transducer array is configured to sequentially steer the focused acoustic energy to regions of the unique tissue locations until the delivered electrical energy is detected or a preset time limit has been reached.
14. The system of claim 11, wherein the system is configured to map the cardiac tissue location.
15. The system of claim 12, wherein the electrodes are configured to collect EGM data at the cardiac tissue location.
16. The system of claim 12, wherein the system is configured to map the cardiac tissue location electromechanically by combining the 3D motion data with the EGM data.
17. The system of claim 16, wherein the system is configured to measure mechanical delay during intrinsic conduction.

18. The system of claim 17, wherein the system is configured to determine change in mechanical delay as a result of electrical stimulation of the left ventricle, electrical stimulation of the right ventricle, intrinsic conduction.

19. The system of claim 10, wherein the system is configured to determine the magnitude of the motion through the cardiac cycle.

20. The system of claim 18, wherein the system is configured to correlate the magnitude motion to changes in ejection fraction.

21. The system of claim 10, wherein system is configured to control a pacemaker by using the motion of the implantable acoustic receiver.

22. A system for mapping cardiac motion, comprising:
an implantable acoustic controller-transmitter comprising an array of acoustic transducers configured to transmit acoustic energy to a cardiac tissue location; and
at least one implantable acoustic receiver-converter adapted to receive acoustic energy and convert the acoustic energy into electrical energy; wherein the implantable acoustic receiver comprising two electrodes configured to be in electrical connection with tissue and to deliver the electrical energy to the tissue; receiver-converter further comprises two electrodes configured to be in electrical connection with tissue and to deliver the electrical energy to the cardiac tissue;

wherein the system is configured to detect the electrical energy continuously throughout one or more cardiac cycles to dynamically track the 3D motion data of the implantable acoustic receiver and wherein the system is configured to correlate EGM data at the cardiac tissue location to create an electromechanical motion profile.

23. The system of claim 22, wherein the controller-transmitter is configured to transmit an acoustic locator signal and the acoustic receiver is configured to generate an electric location signal in response to the locator signal.

24. The system of claim 23, wherein the system is controller-transmitter is configured to continuously transmit locator signals and to continuously detect location signals throughout one or more cardiac cycles to dynamically track the 3D motion data of the implantable acoustic receiver.

25. The system of claim 22, wherein the transducer array is configured to transmit the acoustic locator signal as a focused acoustic beam and the transducer array is further configured to sequentially transmit a series of the locator signals until the receiver-converter generates a location signal or a preset time limit has been reached.

26. The system of claim 24, wherein the location signal is an electrical output, wherein the electrical output is detected by a sensing circuit comprising an electrode assembly adapted to be in electrical connection with tissue.

27. The system of claim 24, wherein the receiver-converter is adapted to generate an acoustic output and the location signal is an acoustic transmission.

28. The system of claim 22, wherein the system is configured to measure mechanical delay during intrinsic conduction.

29. The system of claim 28, wherein the system is configured to determine change in mechanical delay as a result of electrical stimulation of the left ventricle, electrical stimulation of the right ventricle, intrinsic conduction.

30. The system of claim 22, wherein the system is configured to determine the magnitude of the motion through the cardiac cycle.

31. The system of claim 30, wherein the system is configured to correlate the magnitude motion to changes in ejection fraction.

32. The system of claim 22, wherein system is configured to control a pacemaker by using the motion of the implantable acoustic receiver.

33. A method for mapping cardiac motion, comprising:
transmitting acoustic energy to a cardiac tissue location using an implantable acoustic controller-transmitter comprising an array of acoustic transducers;

converting the transmitted acoustic energy to electrical energy using one or more acoustic receiver-converter;

delivering the electrical energy to the cardiac tissue location using two electrodes configured to be in electrical connection with tissue and to deliver the electrical energy to the tissue;

determining 3D motion data by detecting the electrical energy delivered to the tissue location continuously throughout one or more cardiac cycles;

measuring EGM data at the cardiac tissue location;

creating electromechanical map of the cardiac tissue location by correlating the EGM data and the 3D motion data.

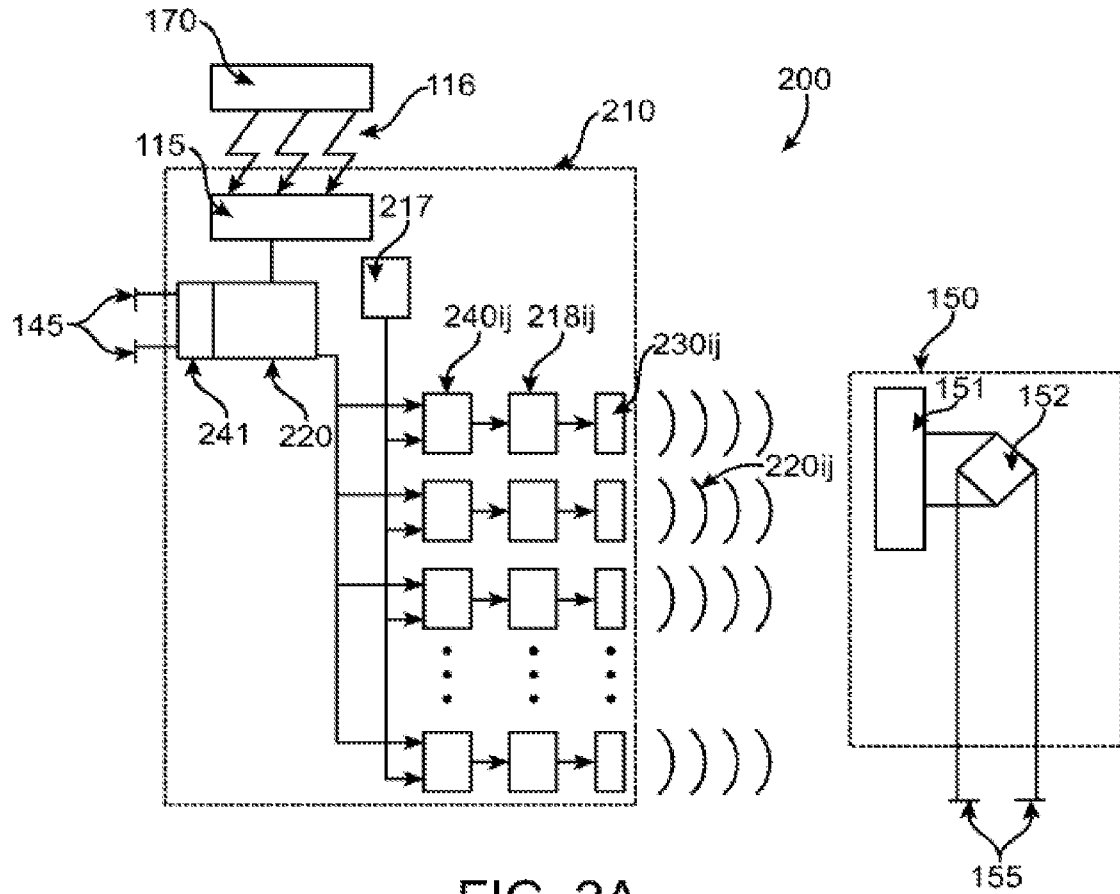

FIG. 2A

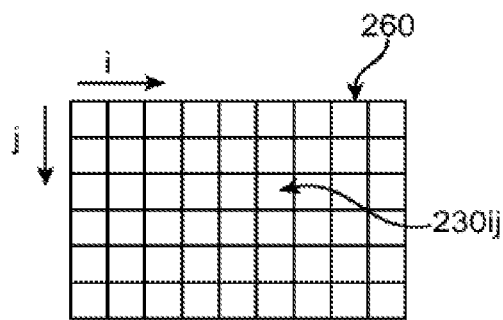

FIG. 2B

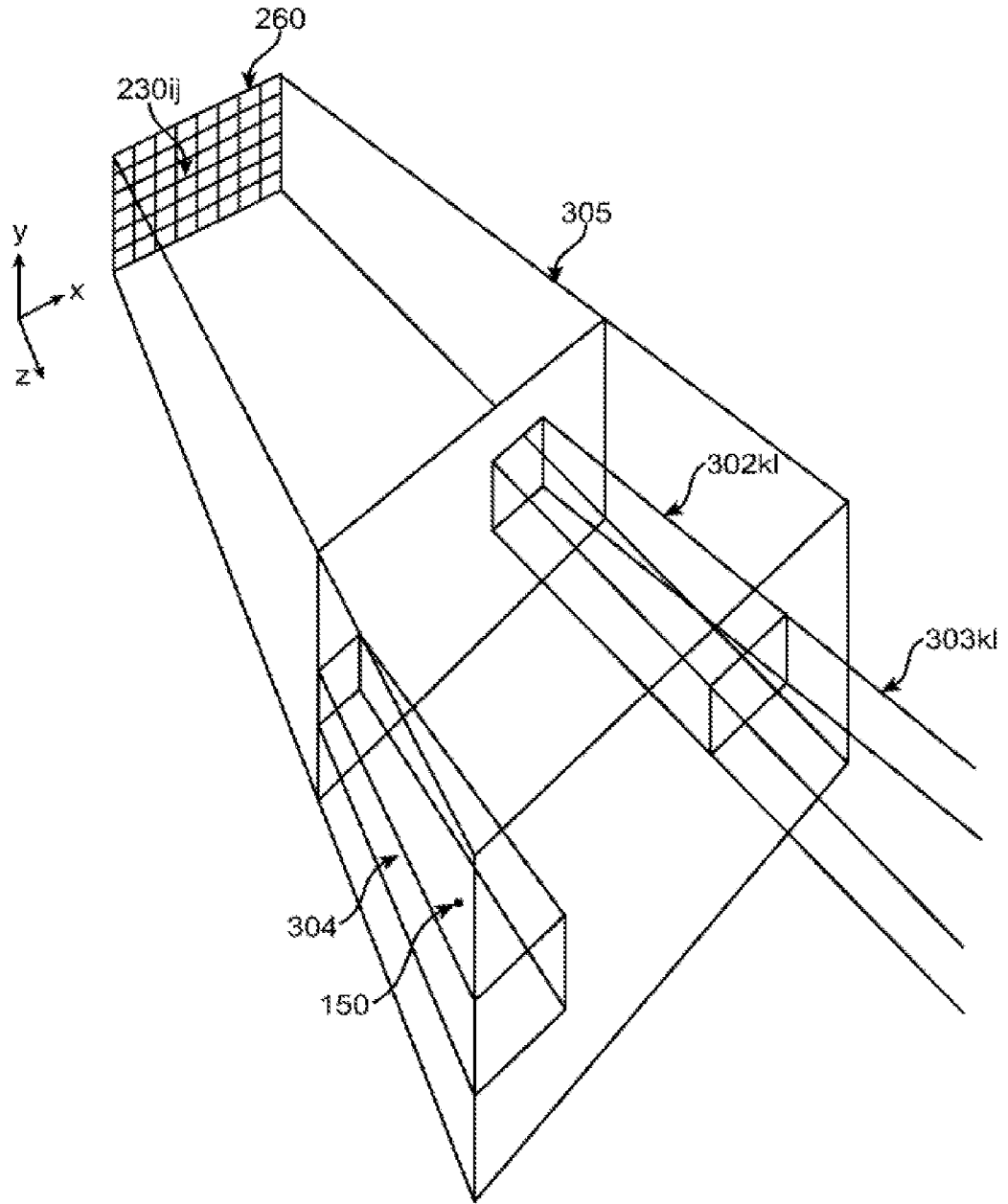

FIG. 3

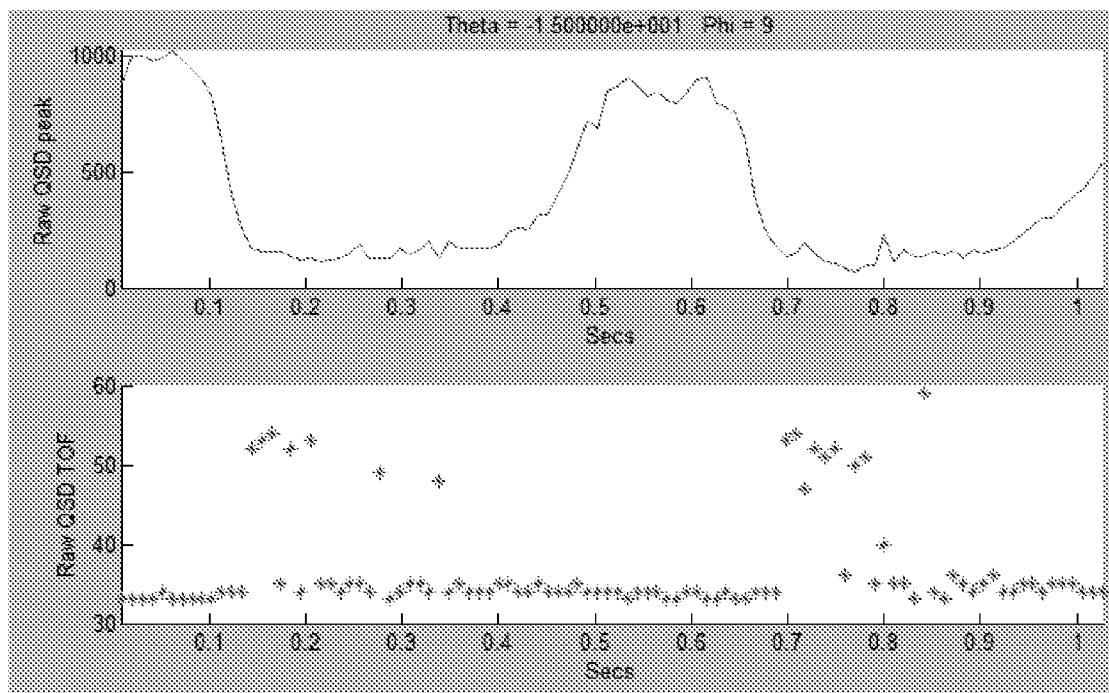

FIG. 4

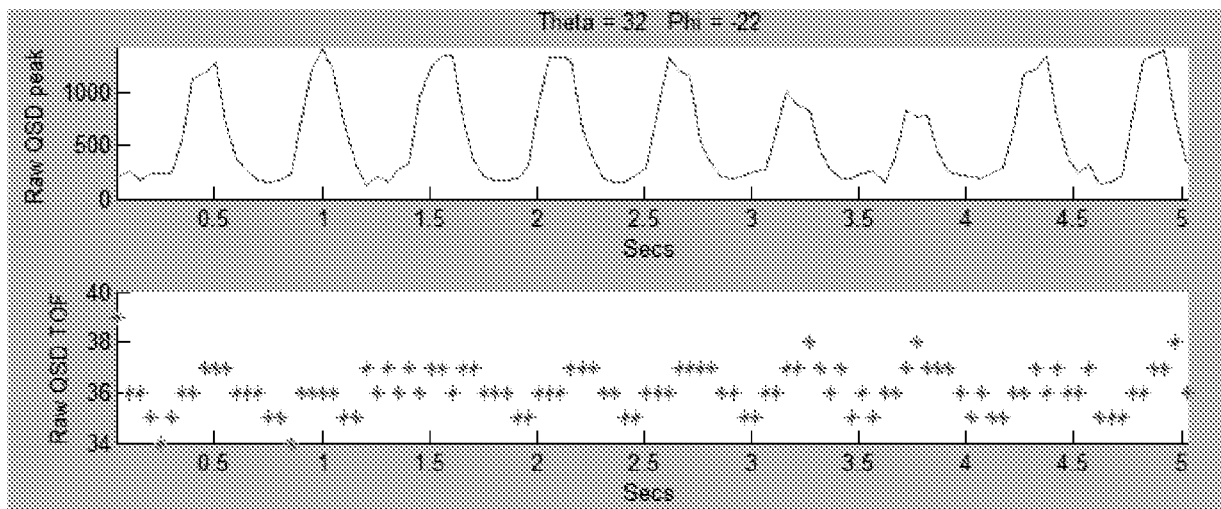

FIG. 5

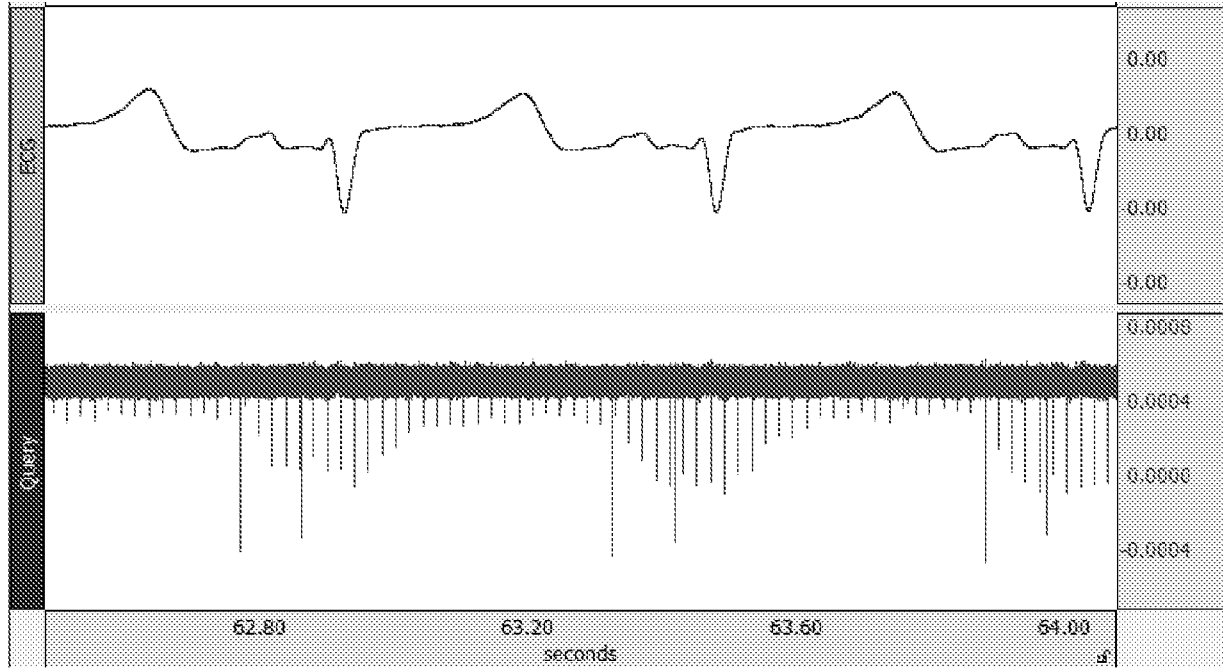

FIG. 6

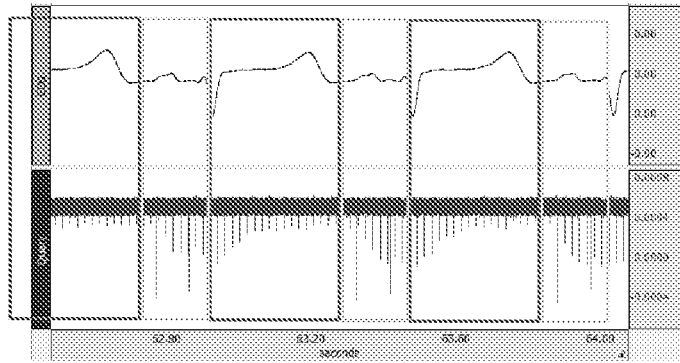

FIG. 7A

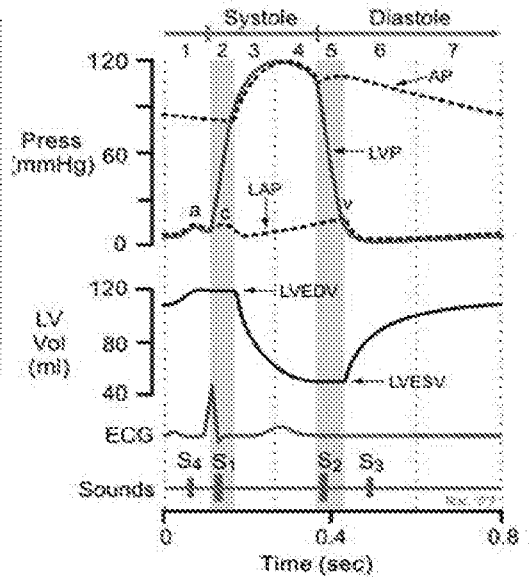

FIG. 7B

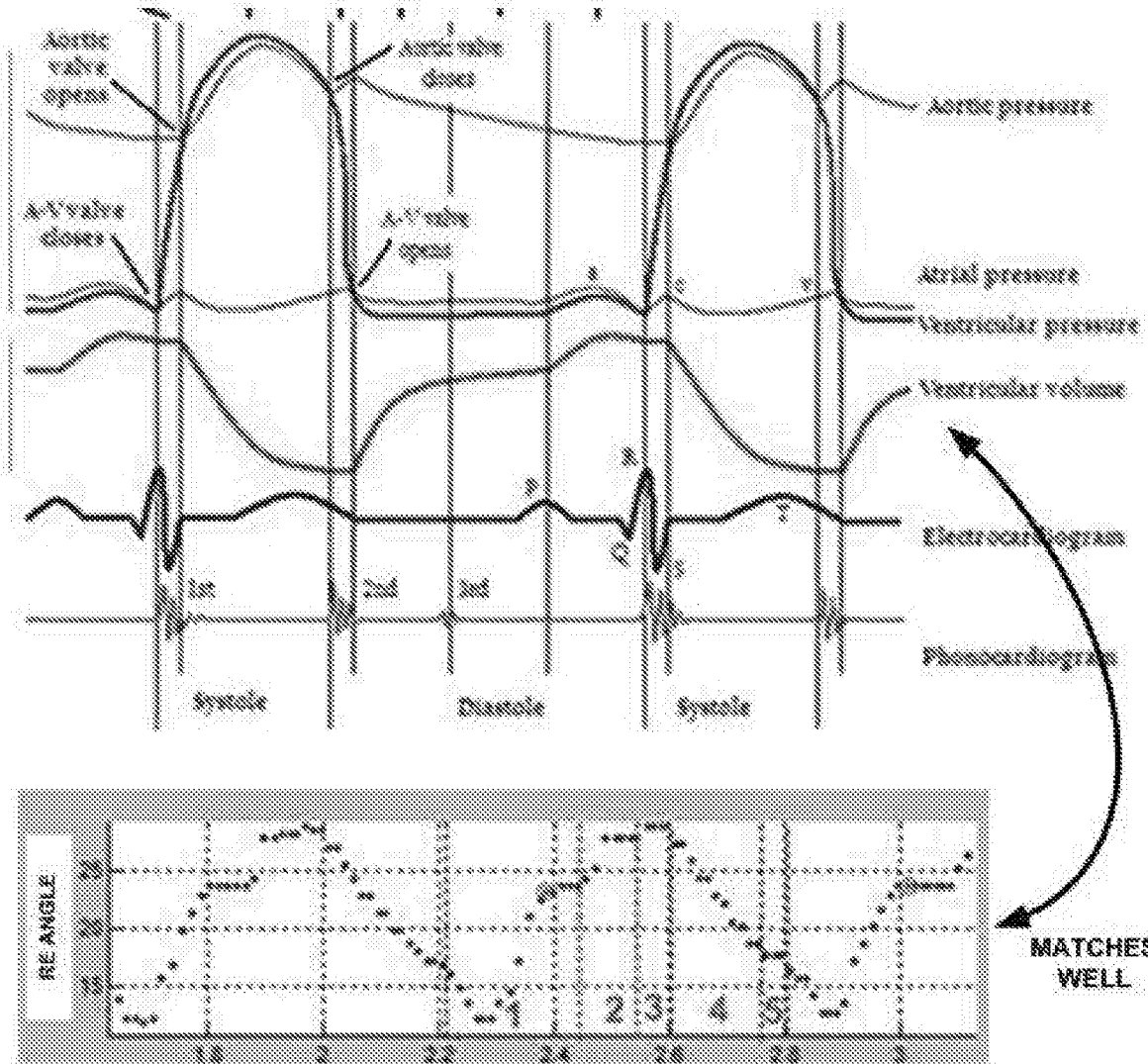

FIG. 8A

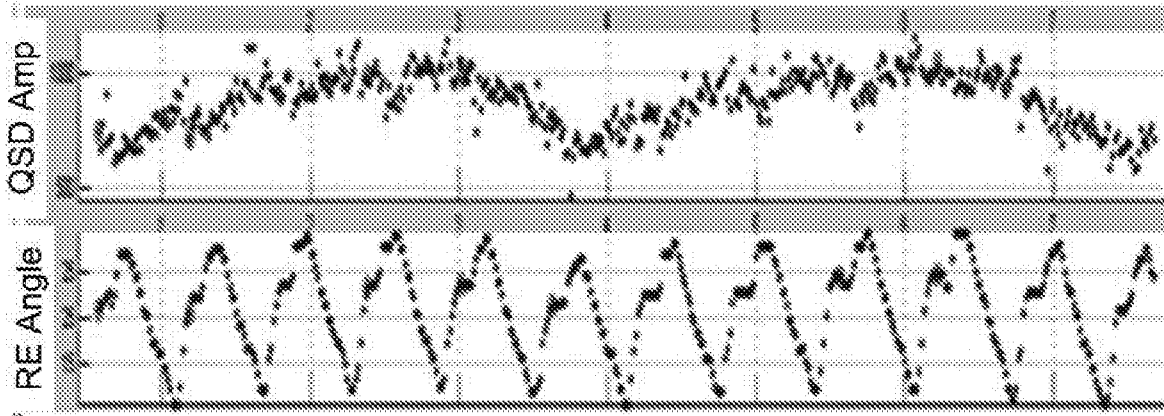

FIG. 8B

FIG. 8C

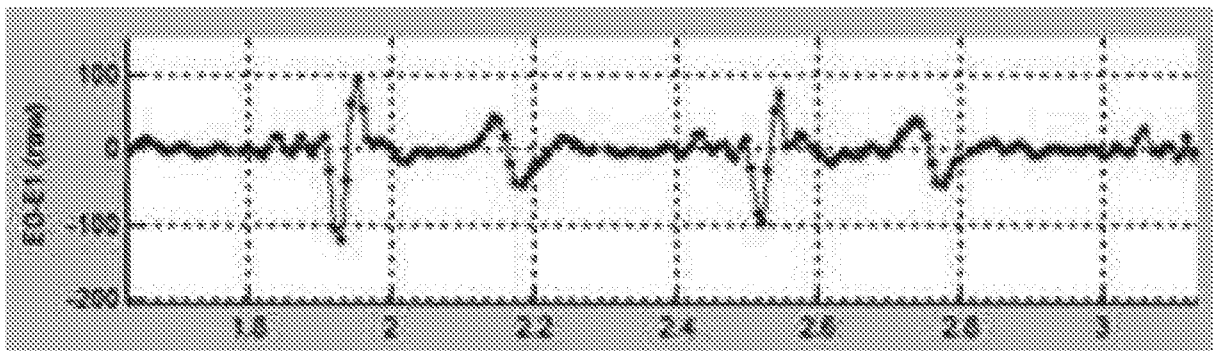

FIG. 8D

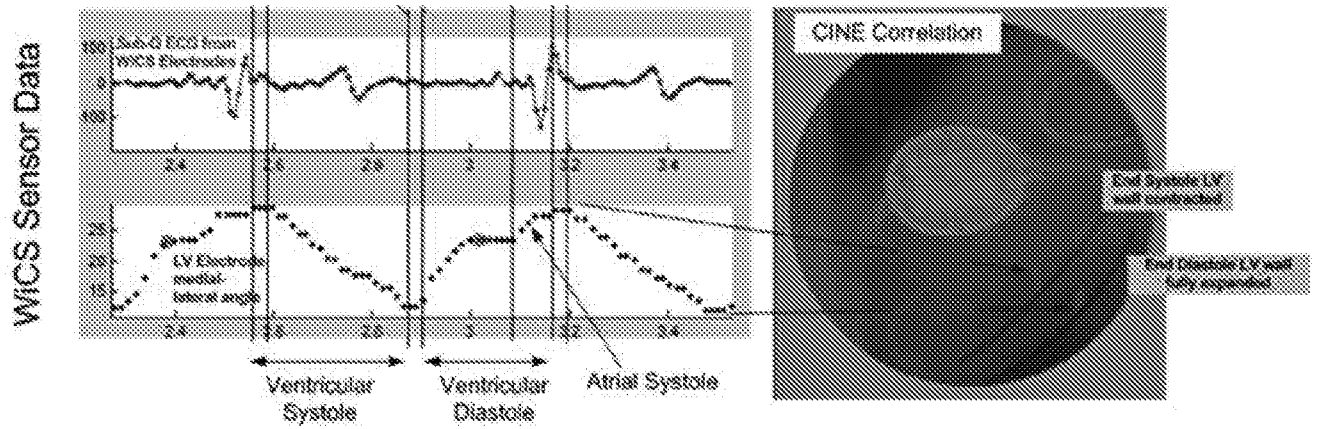

FIG. 9A

FIG. 9B

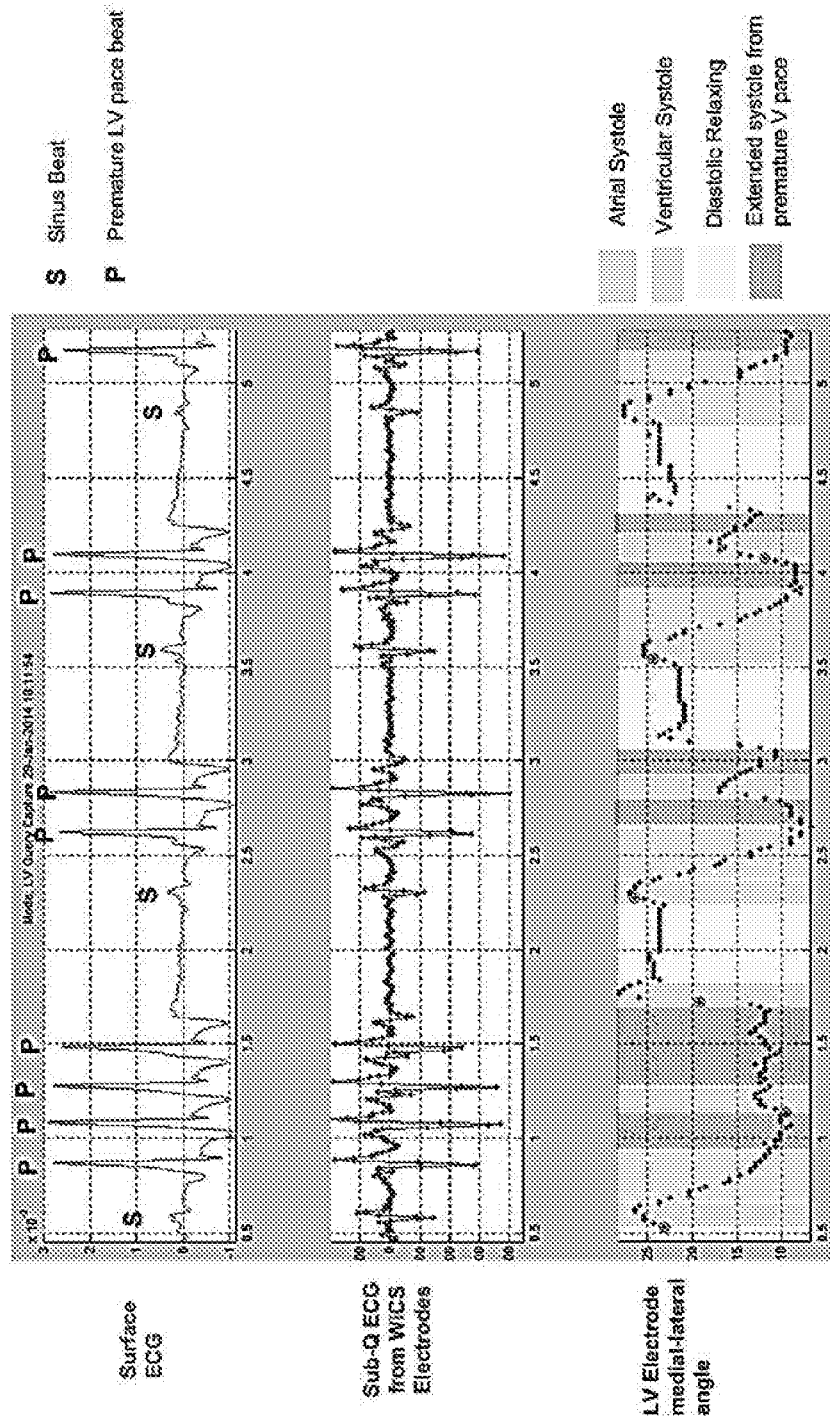

FIG. 10A

FIG. 10B

FIG. 10C

INTERNATIONAL SEARCH REPORT

International application No.
PCT/US2018/044858

A. CLASSIFICATION OF SUBJECT MATTER

IPC(8) - A61N 1/372; A61B 5/00; A61N 1/04; A61N 1/18; A61N 1/36 (2018.01)

CPC - A61N 1/372; A61B 5/00; A61N 1/04; A61N 1/18; A61N 1/36 (2018.08)

According to International Patent Classification (IPC) or to both national classification and IPC

B. FIELDS SEARCHED

Minimum documentation searched (classification system followed by classification symbols)

See Search History document

Documentation searched other than minimum documentation to the extent that such documents are included in the fields searched

USPC - 600/486; 600/508; 600/547 (keyword delimited)

Electronic data base consulted during the international search (name of data base and, where practicable, search terms used)

See Search History document

C. DOCUMENTS CONSIDERED TO BE RELEVANT

Category*	Citation of document, with indication, where appropriate, of the relevant passages	Relevant to claim No.
Y	US 2014/0094891 A1 (EBR SYSTEMS, INC.) 03 April 2014 (03.04.2014) entire document	1-33
Y	US 2011/0319779 A1 (SWEENEY et al) 29 December 2011 (29.12.2011) entire document	1-33
Y	US 2012/0093281 A1 (ZAMYATIN et al) 19 April 2012 (19.04.2012) entire document	8
A	US 2014/0200457 A1 (BOSTON SCIENTIFIC SCIMED, INC.) 17 July 2014 (17.07.2014) entire document	1-33
A	US 2009/0265128 A1 (MARKOWITZ et al) 22 October 2009 (22.10.2009) entire document	1-33

Further documents are listed in the continuation of Box C.

See patent family annex.

* Special categories of cited documents:

"A" document defining the general state of the art which is not considered to be of particular relevance

"E" earlier application or patent but published on or after the international filing date

"L" document which may throw doubts on priority claim(s) or which is cited to establish the publication date of another citation or other special reason (as specified)

"O" document referring to an oral disclosure, use, exhibition or other means

"P" document published prior to the international filing date but later than the priority date claimed

"T" later document published after the international filing date or priority date and not in conflict with the application but cited to understand the principle or theory underlying the invention

"X" document of particular relevance; the claimed invention cannot be considered novel or cannot be considered to involve an inventive step when the document is taken alone

"Y" document of particular relevance; the claimed invention cannot be considered to involve an inventive step when the document is combined with one or more other such documents, such combination being obvious to a person skilled in the art

"&" document member of the same patent family

Date of the actual completion of the international search

27 September 2018

Date of mailing of the international search report

11 OCT 2018

Name and mailing address of the ISA/US

Mail Stop PCT, Attn: ISA/US, Commissioner for Patents
P.O. Box 1450, Alexandria, VA 22313-1450
Facsimile No. 571-273-8300

Authorized officer

Blaine R. Copenheaver

PCT Helpdesk: 571-272-4300
PCT OSP: 571-272-7774

专利名称(译)	机电传感和映射系统，装置和方法		
公开(公告)号	EP3664891A1	公开(公告)日	2020-06-17
申请号	EP2018843742	申请日	2018-08-01
[标]申请(专利权)人(译)	EBR SYST		
申请(专利权)人(译)	EBR系统公司.		
当前申请(专利权)人(译)	EBR系统公司.		
[标]发明人	WILLIS N PARKER		
发明人	WILLIS, N. PARKER		
IPC分类号	A61N1/372 A61B5/00 A61N1/04 A61N1/18 A61N1/36		
CPC分类号	A61B5/04085 A61B5/0422 A61B5/061 A61B5/076 A61B5/1107 A61B2560/0219 A61N1/36507 A61N1/378 A61N1/3787 A61B5/04525 A61B5/1102 A61B5/1126 A61B5/7278 A61N1/025 A61N1/36578 A61N1/37217		
优先权	62/542741 2017-08-08 US		
外部链接	Espacenet		

摘要(译)

公开了用于跟踪和确定心脏植入物的运动的系统,设备和方法。植入物的运动是通过使用包括声换能器阵列的声控制器-发射器将声能传输到组织位置来确定的。其中,植入物被配置为将所传输的声能转换为电能;并且通过确定在一个或多个心动周期中传递到组织的电能来实现跟踪,以创建心脏植入物的运动曲线。