



- (51) **International Patent Classification:**
A61B 6/00 (2006.01) G01S 13/34 (2006.01)
A61B 5/0245 (2006.01)
- (21) **International Application Number:**
PCT/IL201 3/0501 13
- (22) **International Filing Date:**
7 February 2013 (07.02.2013)
- (25) **Filing Language:** English
- (26) **Publication Language:** English
- (30) **Priority Data:**
61/597, 734 11 February 2012 (11.02.2012) US
- (72) **Inventor; and**
- (71) **Applicant : BARAK, Ilan Saul [IL/IL];** 20 Haggai Street, 44335 Kfar Saba (IL).
- (74) **Agents: LUZZATO & LUZZATO et al;** P.O. Box 5352, 84152 Beer Sheva (IL).
- (81) **Designated States** (unless otherwise indicated, for every kind of national protection available): AE, AG, AL, AM, AO, AT, AU, AZ, BA, BB, BG, BH, BN, BR, BW, BY, BZ, CA, CH, CL, CN, CO, CR, CU, CZ, DE, DK, DM,

DO, DZ, EC, EE, EG, ES, FI, GB, GD, GE, GH, GM, GT, HN, HR, HU, ID, IL, IN, IS, JP, KE, KG, KM, KN, KP, KR, KZ, LA, LC, LK, LR, LS, LT, LU, LY, MA, MD, ME, MG, MK, MN, MW, MX, MY, MZ, NA, NG, NI, NO, NZ, OM, PA, PE, PG, PH, PL, PT, QA, RO, RS, RU, RW, SC, SD, SE, SG, SK, SL, SM, ST, SV, SY, TH, TJ, TM, TN, TR, TT, TZ, UA, UG, US, UZ, VC, VN, ZA, ZM, ZW.

(84) **Designated States** (unless otherwise indicated, for every kind of regional protection available): ARIPO (BW, GH, GM, KE, LR, LS, MW, MZ, NA, RW, SD, SL, SZ, TZ, UG, ZM, ZW), Eurasian (AM, AZ, BY, KG, KZ, RU, TJ, TM), European (AL, AT, BE, BG, CH, CY, CZ, DE, DK, EE, ES, FI, FR, GB, GR, HR, HU, IE, IS, IT, LT, LU, LV, MC, MK, MT, NL, NO, PL, PT, RO, RS, SE, SI, SK, SM, TR), OAPI (BF, BJ, CF, CG, CI, CM, GA, GN, GQ, GW, ML, MR, NE, SN, TD, TG).

- Published:**
- with international search report (Art. 21(3))
- before the expiration of the time limit for amending the claims and to be republished in the event of receipt of amendments (Rule 48.2(h))

(54) **Title:** A MICROWAVE CONTACTLESS HEART RATE SENSOR

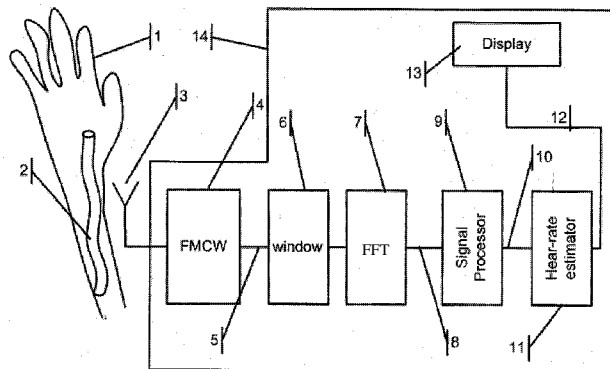

Fig. 1

(57) **Abstract:** A heart-rate sensor for detecting artery blood-flow volume per unit length change in a human or animal subject, which comprises an antenna for sensing the instantaneous volume of blood in the artery of the subject, to be measured; a RADAR unit for transmitting microwave signals into a subject's body part or limb representing tissue targets. The output of the RADAR unit includes a superposition of signals each of which corresponding to a different tissue target with amplitudes that relate to the target's reflection strength; a sampling circuitry for converting reflected signals to digital; a window function circuitry for suppressing unwanted spectral sidebands originating from the subsequent processor operating on time truncated data; an FFT processor following the window function circuitry, for splitting the superposition according to its relative frequency into a multiplicity of bins, each of which with an amplitude that represents the reflection magnitude of a target at a specific distance from the antenna; a signal processor for filtering out the effect of the sensor movement with respect to the subject body part, or the movement of the body part, and for generating a signal, the amplitude of which is proportional to the artery varying dilatation representing the heart-rate; a heart-rate estimator for measuring the frequency of the artery dilatation variations and for canceling the interference of the amplitude of any signal that does not originate from the artery; a battery for powering the sensor.



A MICROWAVECONTACTLESS HEART RATE SENSOR

Field of the Invention

The present invention relates to the field of heart rate sensors. More particularly, the present invention relates to a contactless heart-rate sensor for continuously measuring of heart pulse rate of a human subject or an animal, by utilizing a low power compact microwave sensor.

Background of the Invention

Conventional heart-rate sensors are embedded in monitors and are commonly used in training and sports. There are two common types of heart-rate sensors:

The first type: is a monitor comprising a chest strap sensor and a receiver integrated into a wristwatch. The strap receives ECG signals from the heart and transmits them to the receiver. An example for this type is RS400 Heart Rate Monitor (manufactured by Polar). The chest belt receives ECG signals from the objects body chest via two electrical contacts, and transmits them to the receiver in the wristwatch.

The chest strap associated with this type is inconvenient to wear. Also, in some individuals, the ECG signal reception is too weak, due to the varying body surface resistance. This may result in intermittent pulse rate measurements. This monitor type is the only practical solution currently available for continuous heart rate measurement during exercise.

The second type: is a beltless heart rate monitor where an ECG sensor is integrated in a wristwatch. The ECG signals are conducted to the measurement device inside the watch via the two subject's arms. It requires the user to close an electrical circuit by touching the watch with his other hand. An example of this product is the PM18 by Beurer GmbH. However, for continuous pulse rate readout during training, it is

impractical to use the beltless solution, as it requires the continuous connection of both hands.

Another type of heart-rate monitor available on the market is ring-shaped, like the Multifunction Digital Ring by Lifespan. This monitor is worn on the finger, utilizing a sensor that measures the blood pulsating in the finger, using infrared imaging. However, this measurement is not sufficiently accurate, especially while in training.

US4085740 discloses heart-rate measurement using microwave sensors. Also, James C. Lin, in his paper titled "Microwave Apexcardiography" in Transactions On Microwave Theory And Techniques, Vol. Mtt-27, No. 6, June 1979 teaches a measurement method of the heart rate, directly from the heart movement. Lin utilized a quadrature homodyne detector to detect the amplitude and phase of the reflected signal from the heart.

US4958638 teaches a method to measure the heart-rate and respiratory rate by directly measuring the heart and lungs movements. This method is able to distinguish between movements of the two. This patent describes a frequency modulated radar, which can be interpreted as FMCW as suggested by US 2010/0179438. However, both patents do not deal with the problem of separating the heart pulse rate measurement from other body organ movements. Such movements frequency, in the case of sport training, fall within the normal heart rate frequency range and are not easy to filter out.

Attempts have been made to filter this interference, for example in US5807267 that suggests using an additional accelerometer to measure the body movement frequency and cancel it, using an FFT (Fast Fourier Transform) technique. FFT for this application implies a long measurement time for reasonable accuracy, which

cannot be tolerated in this type of application. Another example of this technique is described in a promotional activity by Epson describing a prototype E200 pulse watch, for example as described in their internet site at http://global.epson.com/innovation/technology_articles/201206_2.html.

All the sensors described above have not provided a satisfactory solution to the problem of the problem of separating the heart pulse rate measurement from other body organ movements and are not sufficiently accurate.

It is therefore an object of the present invention to provide a wireless heart-rate sensor that can separate the heart pulse rate measurement from other body organ movements.

It is another object of the present invention to provide a wireless heart-rate sensor that is accurate, especially for measurements that are made while training.

It is a further object of this invention to facilitate heart rate measurements from a body part which is covered by apparel or by natural fur.

Other objects and advantages of the invention will become apparent as the description proceeds.

Summary of the Invention

The present invention is directed to a heart-rate sensor for detecting artery blood-flow volume per unit length change in a human or animal subject, which comprises:

- a) an antenna for sensing the instantaneous volume of blood in the artery of the subject, to be measured;
- b) a RADAR unit (e.g., a Modulated Continuous Wave (FMCW) radar) for

- 4 -

transmitting, via the antenna, microwave signals into a subject's body part or limb representing tissue targets, the output of the RADAR unit including a superposition of signals, each of which corresponding to a different tissue target, where their amplitudes relate to the target's reflection strength;

- c) a sampling circuitry for converting reflected signals to processable digital representation, preferably at a sampling rate of 10 Hz;
- d) a window function circuitry (e.g., a Kaiser window with $\beta=0.5$, a Tukey Window or a window used in connection with Digital Fourier Transforms), for suppressing unwanted spectral sidebands originating from the subsequent processor operating on time truncated data;
- e) a function processor (such as an FFT function) following the window function circuitry, for splitting the superposition according to its relative frequency into a multiplicity of bins, each of which having an amplitude that represents the reflection magnitude of a target at a specific distance from the antenna;
- f) a signal processor for filtering out the effect of the sensor movement with respect to the subject body part, or the movement of the body part, and for generating a signal, the amplitude of which is proportional to the artery varying dilatation representing the heart-rate; and
- g) a heart-rate estimator for measuring the frequency of the artery dilatation variations and for canceling the interference of the amplitude of any signal that does not originate from the artery;
- h) a power source (e.g., a battery such as a coin type battery) for powering the sensor.

The microwave signal may have a bandwidth of at least 3 GHz.

The RADAR unit may be a Stepped Frequency RADAR or a pulsed RADAR, or

- 5 -

may be adapted to use FMCW with a sweep time of 10 μ sec and the sampling frequency of the ADC is 3.2 MHz. The FMCW RADAR unit may use triangle wave modulation, multirate ramp, triangular wave modulation or wideband sine-wave modulation.

The interference may be eliminated using Multiple Reference ANC, Recursive Least Squares (RLS), Least Mean Square (LMS), Filtered-X LMS (FxLMS) or FuLMS.

Preferably, the heart-rate sensor may be integrated into a wristwatch.

The heart-rate sensor may include a voltage controlled oscillator (e.g., a variable frequency ring oscillator, fabricated using standard CMOS or BiCMOS technologies) modulated by a ramp signal spanning the full signal bandwidth from 3.1 to 10.6 GHz with a typical sweep time of 10 μ s. The VCO output may be coupled to the antenna and to the LO input of a mixer that mixes with the VCO signal to produce an IF signal which is filtered by a Low Pass Filter (LPF) and amplified by an IF amplifier, before being sampled by an Analog to Digital Converter (ADC).

The frequency variation of the oscillator may be in discrete steps.

The antenna may be a dual planar cross-bow dipole antenna which comprises two orthogonal broadband dipoles, a single arm spiral antenna, a single broadband dipole antenna or a slot antenna.

The frequency analysis for splitting the superposition may be performed by using DFT, a chirp-Z transform, or an analog filter bank.

- 6 -

The RADAR unit may operate at a duty cycle below 1%.

The FMCW chirp width may be at least 5 GHz.

The heart-rate sensor may include circuitry for cancellation of interference caused by a movement of the sensor, by using signals from a plurality of time bins.

The interference cancellation may be based on weighted ratios (the ratio between the amplitude of the signal reflected from the artery, to the amplitude of the signal reflected from the skin) of polynomials of multiplicity of range gate bins amplitudes; on adaptive noise cancellation whose input signals are a plurality of these range gate bins amplitudes or on adaptive noise cancellation, where additional one or more inputs are taken from an acceleration sensitive device.

Preferably, the oscillator bandwidth is more than 5 GHz.

The heart-rate sensor may comprise two orthogonal antennas, one for transmitting and one for receiving.

The heart-rate sensor may further include a radio transmitter to relay heart rate data to a remote receiver or terminal and a wrist strap enabling wearing on wrist.

The heart-rate sensor may be embedded in a shoe.

The present inventor is also directed to a method for measuring the heart-rate in a subject, according to which the instantaneous volume of blood in the

- 7 -

artery of the subject is sensed by an antenna and microwave signals are transmitted by a RADAR unit, via the antenna, into a subject's limb representing tissue targets. The output of the RADAR unit includes a superposition of signals, each of which corresponding to a different tissue target, where their amplitudes relate to the target's reflection strength. Reflected signals are converted to processable digital representation by a sampling circuitry and unwanted spectral sidebands originating from the subsequent processor operating on time truncated data are suppressed by a window function. The superposition is split by using an FFT function, according to its relative frequency into a multiplicity of bins, each of which having an amplitude that represents the reflection magnitude of a target at a specific distance from the antenna. Then the effect of the sensor movement with respect to the subject body part is filtered out and a signal, the amplitude of which is proportional to the artery varying dilatation representing the heart-rate is generated. The frequency of the artery dilatation variations is measured and the interference of the amplitude of any signal that does not originate from the artery is canceled.

Brief Description of the Drawings

In the drawings:

Fig. 1 is a top level block diagram usable in an embodiment of the invention;

Fig. 2 is a cross section of a human arm, showing the location of the radial artery;

Fig. 3 is a simplified block diagram of the sensor integrated into a wristwatch, usable in an embodiment of the invention;

Fig. 4 is a block diagram of the sensor, usable in an embodiment of the invention;

Fig. 5 is a block diagram of an alternative embodiment using a single antenna;

Fig. 6 shows the waveform of the detected pulse signal, and the points of extraction of heart-rate related measurements; and

Fig. 7 shows a dual planar cross bow dipole antenna, used by the present invention.

Detailed Description of Preferred Embodiments

The sensor proposed by the present invention measures the variations in the blood volume flowing through the artery, by means of a microwave sensor, to produce a continuous reading of the heart-rate. The measurement is insensitive to rhythmic relative movement of the sensor and subject, making it suitable for performing accurate heart-rate measurements, while the user is in training.

In a preferred embodiment, the measurement is performed on a human wrist, where the artery diameter varies by approximately 10% of its nominal value of approximately 2.5 mm during the pulse cycle.

The heart-rate sensor is located on a relevant body part, for example a limb above the artery to be measured. The proposed sensor transmits a microwave signal into the artery. The amplitude of the signal reflected from this artery depends on its instantaneous diameter, which in turn, represents the instantaneous blood pressure. Monitoring the rhythm or frequency of this reflection allows estimating the subject's heart-rate.

Three interference mechanisms exist in this measurement setup:

1. Additive interference: the sensor also receives reflected waves from other tissues. For example, the reflection from the subject's skin can be much stronger than the reflection from the artery. If the skin's reflection varies rhythmically, for example when the subject is jogging, it will interfere with the reflection from the artery, and reduce the measurement accuracy.
2. Multiplicative interference: The reflected signal that is received also depends on its distance from the target. As this distance varies rhythmically, the reflected signal from the artery will vary too. This will produce a spurious modulation on the reflected signal. This will introduce an unwanted

- 9 -

interference to the measurement, as well.

3. The subject's artery diameter varies in relation to the body part acceleration, for example while running. This also changes the artery diameter, regardless the heart pulse.

As the rhythm, or frequency, of movement that causes the interferences can be in the same frequency range as the heart-rate to be measured, these interferences must be excluded from the measurement.

In order to separate between the required signal and the interferences, the present invention uses RADAR technology, namely FMCW, also sometimes called Linear FM (LFM) or chirp. This RADAR technology allows separating the reflections that originate from different distances from the antenna, thus allowing the separation of the reflection from different tissues. These different signals, one which originates primarily from the artery, and the others which originate from other tissue which are not responsive to the heart pulse, will allow separating the heart rate pulse signal, from interferences caused by the movement.

The following discussion relates to pulse measurement from an artery that is embedded in a limb. The measured artery can also be embedded in other body parts, of humans or animals, and operate in the same manner. Fig. 1 shows a simplified block diagram of the sensor proposed by the present invention. The Sensor 14 is connected to antenna 3 for sensing the instantaneous volume of blood in the artery 2 to be measured. A Frequency Modulated Continuous Wave (FMCW) RADAR 4 transmits microwave signals into the subject limb 1, in this case into the arm, via antenna 3. The limb represents to the RADAR a multiplicity of tissue targets, each of which at a different distance from the antenna 3. The RADAR output 5 includes a superposition of signals, each of which corresponding to a specific tissue target. The frequency of each such a signal is related to the distance of the target, and its

- 10 -

amplitude is related to the target's reflection strength, usually referred to as Radar Cross Section (RCS). An FFT function processor 7, followed by window function circuitry 6, splits the superposition of target information in output 5 according to its relative frequency, hence its distance, into a multiplicity of bins (bars that contain energy from a frequency range). Each bin output amplitude represents the RCS of the target at a specific distance from the antenna, which is equivalent to a specific depth inside the limb. Window function 6 is needed to suppress spectral sidebands originating from the abrupt start and stop of signal 5 (i.e., from the subsequent processor operating on time truncated data), due to using the FMCW radar.

Fig. 2 shows an example of the FFT output in relation to the limb tissues. In this example, the limb is a human wrist. Its cross section 20 is shown, and includes for this simplistic illustration, three tissue elements: the skin 21, the artery 22, and a bone 23. The corresponding output of three FFT bins is shown in 24, also correspond to output signal 5 in Fig. 1. Bin 0 signal is represented by vector 25. It is a result of the lowest frequency component of signal 5, and is related to the nearest tissue, the skin 21. Bin 1 signal is represented by vector 26, and is the result of the reflection from the farther situated artery 22. Bin 2 signal is represented by vector 27, and is the result of the reflection of the even farther situated bone 23. The different FFT bins are referred hereafter as range gates, as they represent signals originating from targets in different ranges.

Returning back to Fig. 1, the FFT bins are connected via bus 8 to signal processor 9. Signal processor's 9 task is to filter out the effect of the sensor movement in respect to the limb. Signal processor 9 generates a signal 10 that essentially represents only the reflection from the artery. Signal 10 amplitude is proportional to the artery dilatation, which varies in accordance with the blood pulsating in the artery and therefore, is an essentially periodic signal, whose frequency represents the heart-rate. Heart-rate Estimator 11 measures this frequency and forwards it for display

13 via signal 12.

In this example, the signal in bin 1 of the FFT represents the dilatation of the artery, and does not include the interfering signals from the other tissue elements, thus eliminating the additive interference described above. The signal in bin 1 does, however, include the multiplicative interference as described above. The signals in the other bins also include this same multiplicative interference, but do not include the time varying component associated with the heart-rate, as they are reflected from other tissue elements.

The sensor proposed by the present invention detects the multiplicative interference from the other bins, and uses it to cancel the interference on the bin representing the artery dilatation, namely bin 1 in this example. A simple implementation of this cancellation is achieved by dividing the amplitude of the signal resulting from the artery by the amplitude of a signal that does not originate from the artery.

Different tissues in a human wrist are located in tight proximity. For example, the distance of the artery from the skin and the artery's depth, is approximately 3.5 mm. In order to separate the signals reflected from so close objects, a large signal bandwidth is needed. For an FMCW application, the signal bandwidth should be at least 3 GHz, and optimal performance can be achieved with a bandwidth of 6 GHz or more.

According to a preferred embodiment of the invention, Ultra Wideband (UWB) spectral allocation between 3.1 GHz to 10.6 GHz is used, since it complies with the existing legislation permitting this use.

By using this frequency range for measuring tissues inside a limb, a range resolution of approximately 3mm can be obtained. In a preferred embodiment of this

invention, the FMCW sweep time is 10 μ sec and the sampling frequency of the Analog to Digital Converter (ADC) is set to 3.2 MHz. With these parameters, the FFT will have 32 bins, with no zero padding (appending one or more zeros to the end of a signal). The FFT bin 0 will represent the reflection from the skin, and the bin 1 will predominantly represent the reflection from the artery.

In this preferred setup, the error free signal representing the reflection from the artery can be generated by calculating the weighted ratio of two polynomials, so that the error free resulting signal is calculated by:

$$Sig = \frac{b_0 + \sum (p_i(x_i))}{a_0 + \sum (q_i(x_i))}$$

where p_i and q_i are polynomials of arbitrary degree and x_i are the signal amplitudes corresponding to the various FFT bins. The index i represents the bin number, where $i=0$ represents bin 0. This calculation is repeated in relation to the FMCW chirp repetition.

The p_i and q_i coefficients can be fixed values, as in this preferred embodiment. In other embodiments they can be dynamically set by the processor 9 during a user initiated calibration phase, at start-up, or during the operation of the sensor. This way, different artery depths in different subjects can be handled. These weighting constants can also be adapted to handle the changing dielectric parameters of the subject, caused by physiological changes while exercising or by other reasons. Such physiological changes may be, for example, temperature changes of the tissue, changes in the sweat level on the skin surface, or changing in blood flow.

In an alternative embodiment, the interference associated with the relative movement, as well as the artifact interference can be eliminated using Multiple Reference ANC (Adaptive Noise Cancellation), as described in the thesis of "Multiple

Reference Active Noise Control" by Yifeng Tu, Virginia Polytechnic Institute and State University March, 1997, the content of which is incorporated herein by reference. The inputs to this noise cancellation algorithm are a multiplicity of FFT bins, and possibly also inputs from an accelerometer or acceleration sensitive device, sensing the acceleration along one or more axes.

The adaptive algorithm may include Recursive Least Squares (RLS), least mean square (LMS) and their derivatives, such as Filtered-X LMS (FxLMS) or FuLMS.

Another possible implementation of this RADAR unit can be the pulsed RADAR method. Additionally, other frequency bands may be used. It should be recognized by those skilled in the art that the bandwidth needed for other RADAR types, for example pulsed RADAR, is at least the same bandwidth needed for the FMCW RADAR.

Other embodiments of this invention may include using other types of FMCW RADARs, for example Stepped Frequency Radar (SFR-a radar in which the echoes of stepped frequency pulses are synthesized in the frequency domain to obtain wider signal bandwidth, to achieve high range resolution, without increasing system complexity), triangle wave modulation, multirate ramp, and triangular wave modulation. Also, it is possible to use wide band sine wave modulation.

In a preferred embodiment of this invention, the sensor is integrated into a wristwatch, as shown in Fig. 3. The functional part of the proposed sensor 14 is mounted inside the wristwatch housing 33, and the antenna 31 is mounted in the wristwatch strap 30, above the radial artery. The antenna 31 is connected to the FMCW circuit via transmission line 32.

Fig. 4 is a detailed block diagram of the sensor 14 to be embedded in the watch,

- 14 -

according to a preferred embodiment of this invention. A voltage controlled oscillator (VCO) 41 (for generating the microwave signal) is modulated by a ramp signal 46 and spans the full signal bandwidth, which preferably spans from 3.1 to 10.6 GHz. A typical sweep time would be 10 μ s. The selection of this sweep time will cause the detected signal representing the artery to be at approximately 125 KHz. This frequency is high enough to minimize the effect of the semiconductor's shot noise on the Signal to Noise Ratio (SNR). Other sweep times can be selected as needed in different practical implementations. In the preferred embodiment, the VCO output is coupled to the antenna 3a, and also to the LO input of mixer 42. In the preferred embodiment, the antenna 3b receives the reflected signal from the artery, that mixes with the VCO signal in Mixer 42, to produce an IF signal. This IF signal is filtered by a Low Pass Filter (LPF) 43 and amplified in IF amplifier 44, before being sampled by the Analog to Digital converter (ADC) 45. The IF channel illustrated in Fig. 4 describes a real signal detection.

In an alternative embodiment, the dual antenna 3a and 3b is replaced with a single antenna 3, shown in Fig. 5. This antenna 3 is excited using its RF-to-LO parasitic leakage. The mixer may be purposely designed to leak this signal, which under other circumstances would be unwanted. Alternatively, other coupling mechanisms can be used, including a circulator or a directional coupler.

In both embodiments, the electrical length difference between signal transverse the antenna(s) via the skin reflection and the signal arriving a mixer LO port will define the IF frequency that corresponds to bin 0, or skin reflection. Making this electrical length sufficiently long allows using a single mixer. However, in some cases, specifically for a short electrical length difference, complex detection may be needed. Complex detection may be realized by using a quadrature mixer, and a pair each of LPFs, IF amplifiers, and ADCs. For a complex detection, the VCO needs to provide two outputs, with a constant phase difference of 90 degrees between them,

which must be frequency independent in the sweep frequency range.

The requirement for a large frequency sweep range, and the requirement for a quadrature output, as well as the wish to integrate the microwave circuits and the signal processing circuits into a semiconductor die, can be met by realizing the VCO 41 as a variable frequency ring oscillator, such as a voltage controlled ring oscillator. Such a quadrature ring oscillator can be fabricated using standard CMOS or BiCMOS technologies.

In another preferred embodiment, the frequency variation of the oscillator may be in discrete steps, as in SFR, so digital control of the frequency is possible. The antennas 3a and 3b must support the broadband signal being used, while minimizing cross-talk between them. In this preferred embodiment, a dual planar cross-bow dipole antenna is used, as shown in Fig. 7. This antenna comprises two orthogonal broadband dipoles, one including conductors 60 and 61, and the other including conductors 62 and 63. Artery 65 is located in the X direction, to create an imbalance in the electromagnetic structure and thereby, contributing to the coupling between these dipoles. This allows the diameter or RCS of artery 65 to generate the received signal in the antenna.

An alternative embodiment includes a single antenna 3, as illustrated in Fig 5. This antenna may be a single arm spiral antenna, a single broadband dipole antenna or a slot antenna. In this case, the reflected signal from the antenna is the received signal.

In the preferred embodiment, FFT 7 performs frequency analysis. Alternative embodiments can use other spectral analysis methods, for example: a DFT, a chirp-Z transform, or an analog filter bank. In the preferred embodiment, a window function 6 is a Kaiser window with $\beta=0.5$. Other window functions can be used, for example a

Tukey Window (tapered cosine) or windows used in connection with Digital Fourier Transforms.

In an alternative embodiment, the heart-rate can be estimated using a correlation with a set of predefined wave shapes, each having a slightly different repetition rate. The candidate predefined wave with the highest correlation maximum will be selected as the best estimate. The highest maximum correlation may be detected by using a nonlinear estimator, such as a Maximum Likelihood Sequence Estimator (MLSE).

The signal Sig. 10 resulting from the weighted division shown in Fig. 4, is of the shape 50 of Fig. 6. This signal is processed by heart-rate estimator 11 of Fig. 4, to produce the estimated heart-rate frequency. The preferred detection method is to compare the signal Sig. of shape 50 to its running average 51, and counting the time interval T_i between subsequent positive direction zero crossings, as marked by asterisks on curve 51. In the preferred embodiment the running average is performed by a fourth order Butterworth filter having a 3 dB bandwidth of 0.5 Hz. The actual heart-rate is calculated by performing a running average on 6 measurements of $60/T_i$, where T_i is in seconds. It is possible to use other spectral estimation methods to calculate the heart-rate, for example a Fourier transform.

Since the subject heart-rate cannot exceed a few Hertz, the preferred embodiment uses a sampling rate of 10 Hz. The RADAR subsystem needs to active at a duty cycle of 0.01%. This enables the sensor to consume a very low average power, and makes it suitable for coin battery operation. In alternative embodiments, a higher duty cycle can be used to produce a better signal to noise ratio, and to improve the reading accuracy. In this case, multiple measurements can be performed, and the results can be averaged to improve fidelity.

- 17 -

In a preferred embodiment, the heart-rate sensor is powered by a CR2032 3V lithium coin battery. It is also possible to aid the powering of the heart-rate sensor with other energy sources, for example a rechargeable battery, a solar cell, or an electric generator that generates electricity from the movement of the subject's hand. Any of these methods of generating and storing electrical energy can be combined.

In another embodiment, the heart-rate data can be transmitted to an external recipient that can display the results, such as exercise equipment (e.g., bicycles, exercise treadmills, rowing machines), smart phones, and others.

In another embodiment, the sensor may be used to sense the health of a subject, for example a senior person. In this case, the sensor will test the measured heart rate and will compare it to predefined limits or predefined heart rate variation pattern or heart rate variability. If the measurement exceeds predefined limits, it would then communicate this condition via a wireless communication channel, in order, for example, to alert medical care staff.

Many standards for this transmission exist, and a multiplicity of these communication protocols could be supported:

1. The 5 KHz coded protocol 49, which includes a 5 Khz signal that is PPM modulated by a pulse triplet, each with a width of 5-7 msec for each heart beat.
2. The 5 Khz uncoded protocol 50, which includes a 5 Khz signal that is PPM modulated by a single pulse with a width of approximately 25 msec for each heart beat.
3. The ANT standard 48.
4. The Bluetooth standard 47.

The sensor proposed by the present invention also facilitates heart rate measurements from a body part which is covered by an apparel (e.g., cloth, leather etc.) or by natural fur. For example, the sensor may be integrated into a shoe and is capable of measuring the heart rate of an animal through its fur.

While some embodiments of the invention have been described by way of illustration, it will be apparent that the invention can be carried out with many modifications, variations and adaptations, and with the use of numerous equivalents or alternative solutions that are within the scope of persons skilled in the art, without exceeding the scope of the claims.

CLAIMS

1. A heart-rate sensor for detecting artery blood-flow volume per unit length change in a subject, comprising:
 - a) an antenna for sensing the instantaneous volume of blood in the artery of said subject, to be measured;
 - b) a RADAR unit for transmitting, via said antenna, microwave signals into a subject's body part or limb representing tissue targets, the output of said RADAR unit including a superposition of signals, each of which corresponding to a different tissue target, where their amplitudes relate to the target's reflection strength;
 - c) a sampling circuitry for converting reflected signals to processable digital representation;
 - d) a window function circuitry, for suppressing unwanted spectral sidebands originating from the subsequent processor operating on time truncated data;
 - e) a function processor following said window function circuitry, for splitting said superposition according to its relative frequency into a multiplicity of bins, each of which having an amplitude that represents the reflection magnitude of a target at a specific distance from said antenna;
 - f) a signal processor for filtering out the effect of the sensor movement with respect to the subject body part, or the movement of the body part, and for generating a signal, the amplitude of which is proportional to the artery varying dilatation representing the heart-rate;
 - g) a heart-rate estimator for measuring the frequency of the artery dilatation variations and for canceling the interference of the amplitude of any signal that does not originate from the artery; and
 - h) a power source for powering the sensor.

2. A heart-rate sensor according to claim 1, wherein the microwave signal's

- 20 -

bandwidth is at least 3 GHz.

3. A heart-rate sensor according to claim 1, wherein the radar unit is a Modulated Continuous Wave (FMCW) radar.
4. A heart-rate sensor according to claim 1, wherein the function for splitting the superposition of signals is FFT.
5. A heart-rate sensor according to claim 1, wherein the subject is a human subject.
6. A heart-rate sensor according to claim 1, wherein the subject is an animal.
7. A heart-rate sensor according to claim 1, wherein the RADAR unit uses FMCW with a sweep time of 10 μ sec and the sampling frequency of the ADC is 3.2 MHz.
8. A heart-rate sensor according to claim 1, wherein the interference is eliminated using Multiple Reference ANC, Recursive Least Squares (RLS), Least Mean Square (LMS), Filtered-X LMS (FxLMS) or FuLMS.
9. A heart-rate sensor according to claim 1, wherein the RADAR unit is a Stepped Frequency RADAR.
10. A heart-rate sensor according to claim 1, wherein the RADAR unit is a pulsed RADAR.
11. A heart-rate sensor according to claim 1, wherein the FMCW RADAR unit uses triangle wave modulation, multirate ramp, triangular wave modulation or wideband sine-wave modulation.

- 21 -

12. A heart-rate sensor according to claim 1, integrated into a wristwatch.
13. A heart-rate sensor according to claim 1, comprising a voltage controlled oscillator (VCO) modulated by a ramp signal spanning the full signal bandwidth from 3.1 to 10.6 GHz with a typical sweep time of 10 μ s, for generating the microwave signal.
14. A heart-rate sensor according to claim 13, wherein the VCO's output is coupled to the antenna and to the LO input of a mixer that mixes with the VCO signal to produce an IF signal which is filtered by a Low Pass Filter (LPF) and amplified by an IF amplifier, before being sampled by an Analog to Digital Converter (ADC).
15. A heart-rate sensor according to claim 13, wherein the VCO is a variable frequency ring oscillator, fabricated using standard CMOS or BiCMOS technologies.
16. A heart-rate sensor according to claim 13, wherein the frequency variation of the oscillator may be in discrete steps.
17. A heart-rate sensor according to claim 1, wherein the antenna is a dual planar cross-bow dipole antenna, which comprises two orthogonal broadband dipoles.
18. A heart-rate sensor according to claim 1, wherein the antenna is a single arm spiral antenna, a single broadband dipole antenna or a slot antenna.
19. A heart-rate sensor according to claim 1, wherein the frequency analysis

- 22 -

for splitting the superposition is performed by using DFT, a chirp-Z transform, or an analog filter bank.

20. A heart-rate sensor according to claim 1, wherein the window function is a Kaiser window with $\beta=0.5$, a Tukey Window or a window used in connection with Digital Fourier Transforms.
21. A heart-rate sensor according to claim 1, wherein the sampling rate is 10 Hz.
22. A heart-rate sensor according to claim 1, wherein the RADAR unit operates at a duty cycle below 1%.
23. A heart-rate sensor according to claim 7, wherein the FMCW chirp width is at least 5 GHz.
24. A heart-rate sensor according to claim 1, further including a circuitry for cancellation of interference caused by a movement of the sensor, by using signals from a plurality of time bins.
25. A heart-rate sensor according to claim 1, wherein the interference cancellation is based on a ratio of polynomials of multiplicity of range gate bins amplitudes.
26. A heart-rate sensor according to claim 1, wherein the interference cancellation is based adaptive noise cancellation whose input signals are a plurality of these range gate bins amplitudes.
27. A heart-rate sensor according to claim 1, wherein the interference

- 23 -

cancellation is based on adaptive noise cancellation, where additional one or more inputs are taken from an acceleration sensitive device.

28. A heart-rate sensor of claim 25, wherein the ratio is the ratio between the amplitude of the signal reflected from the artery, to the amplitude of the signal reflected from the skin.
29. A heart-rate sensor according to claim 13, wherein the oscillator is a variable frequency ring oscillator.
30. A heart-rate sensor according to claim 29, wherein the oscillator bandwidth is more than 5 GHz.
31. A heart-rate sensor according to claim 1, which comprises two orthogonal antennas, one for transmitting and one for receiving.
32. A heart-rate sensor according to claim 5, wherein the power source is a battery.
33. A heart-rate sensor according to claim 32, wherein the battery is a coin type battery.
34. A heart-rate sensor according to claim 1, further including a radio transmitter to relay heart rate data to a remote receiver or terminal.
35. A heart-rate sensor according to claim 1, further including a wrist strap enabling wearing on wrist.
36. A heart-rate sensor according to claim 1, embedded in a shoe.

- 24 -

37. A method for measuring the heart-rate in a subject, comprising:
- a) sensing the instantaneous volume of blood in the artery of said subject by an antenna;
 - b) transmitting microwave signals by a RADAR unit, via said antenna, into a subject's limb representing tissue targets, the output of said RADAR unit including a superposition of signals, each of which corresponding to a different tissue target, where their amplitudes relate to the target's reflection strength;
 - c) converting reflected signals to processable digital representation, by a sampling circuitry;
 - d) suppressing unwanted spectral sidebands originating from the subsequent FFT operating on a time truncated data by a window function;
 - e) splitting said superposition by using an FFT function, according to its relative frequency into a multiplicity of bins, each of which having an amplitude that represents the reflection magnitude of a target at a specific distance from said antenna;;
 - f) filtering out the effect of the sensor movement with respect to the subject body part;
 - g) generating a signal, the amplitude of which is proportional to the artery varying dilatation representing the heart-rate; and
 - h) measuring the frequency of the artery dilatation variations and canceling the interference of the amplitude of any signal that does not originate from the artery.

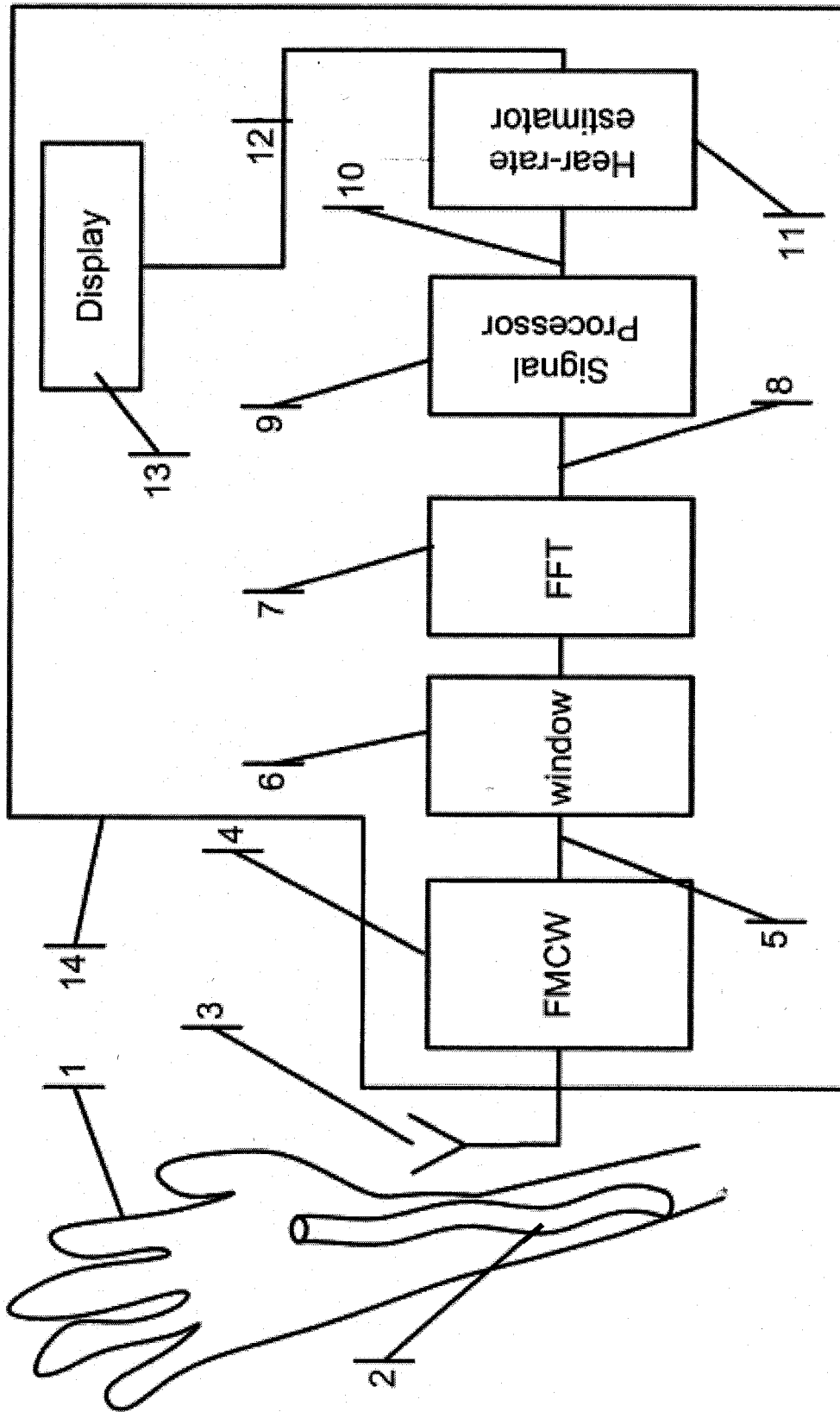

Fig. 1

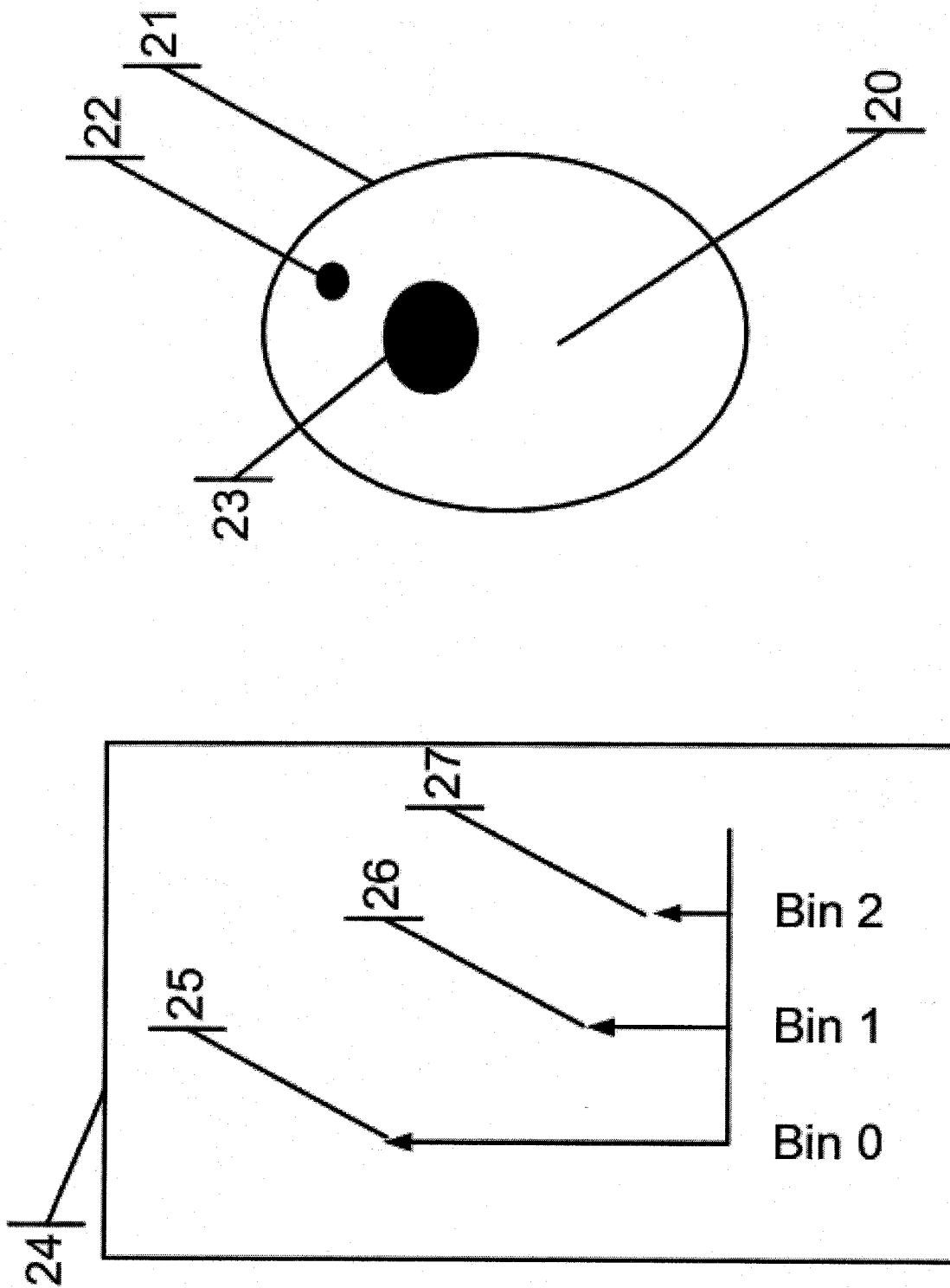

Fig. 2

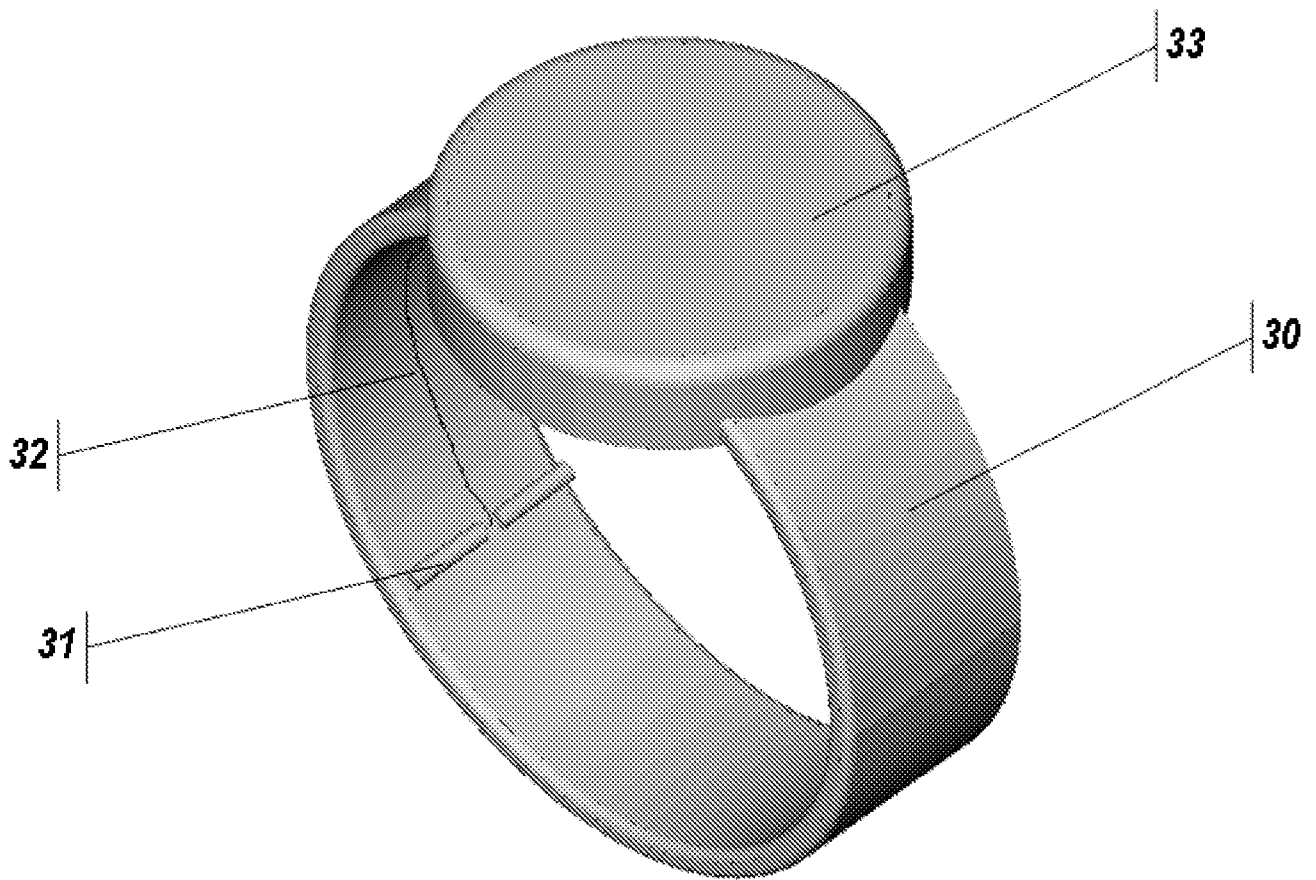

Fig. 3

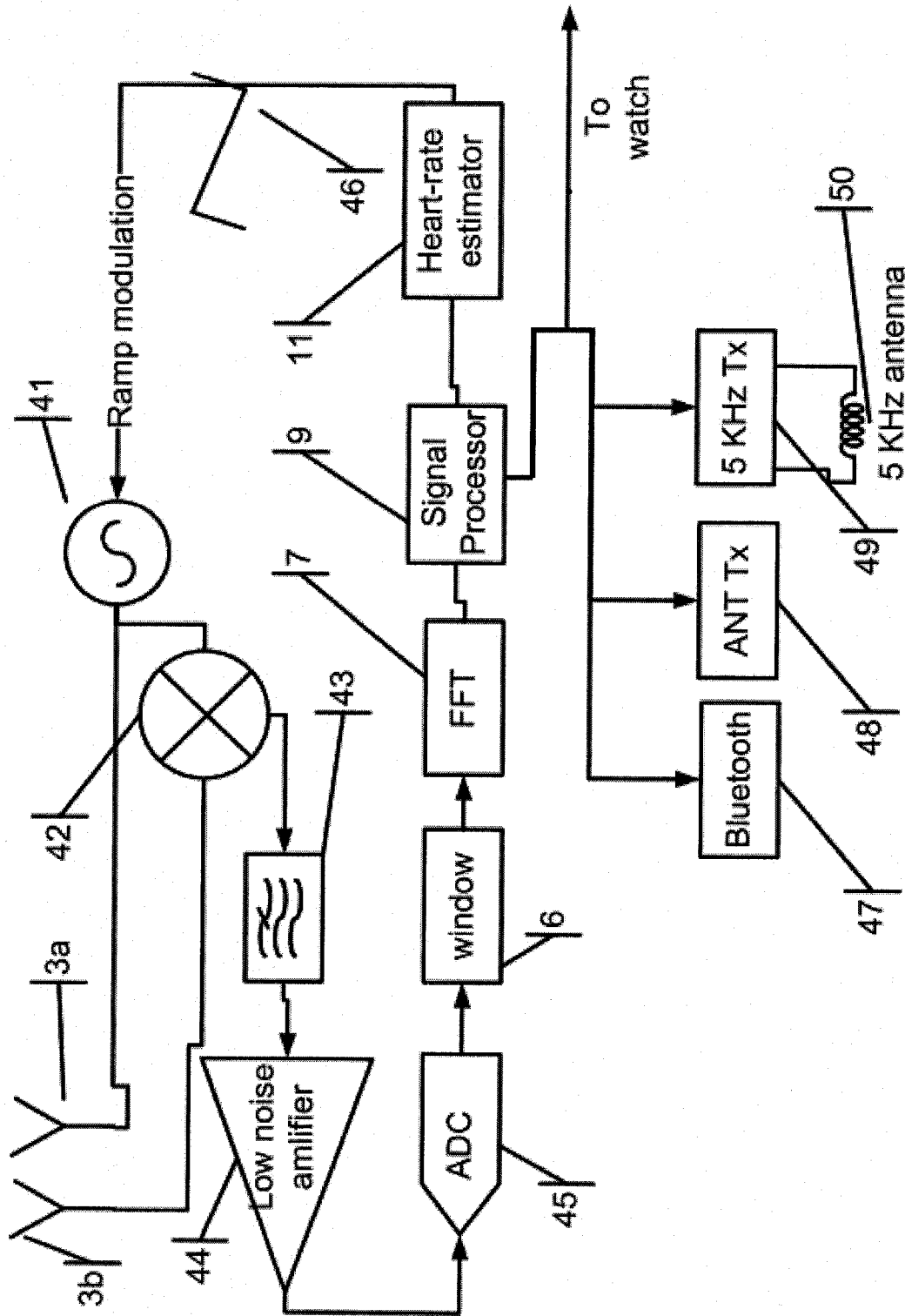

Fig. 4

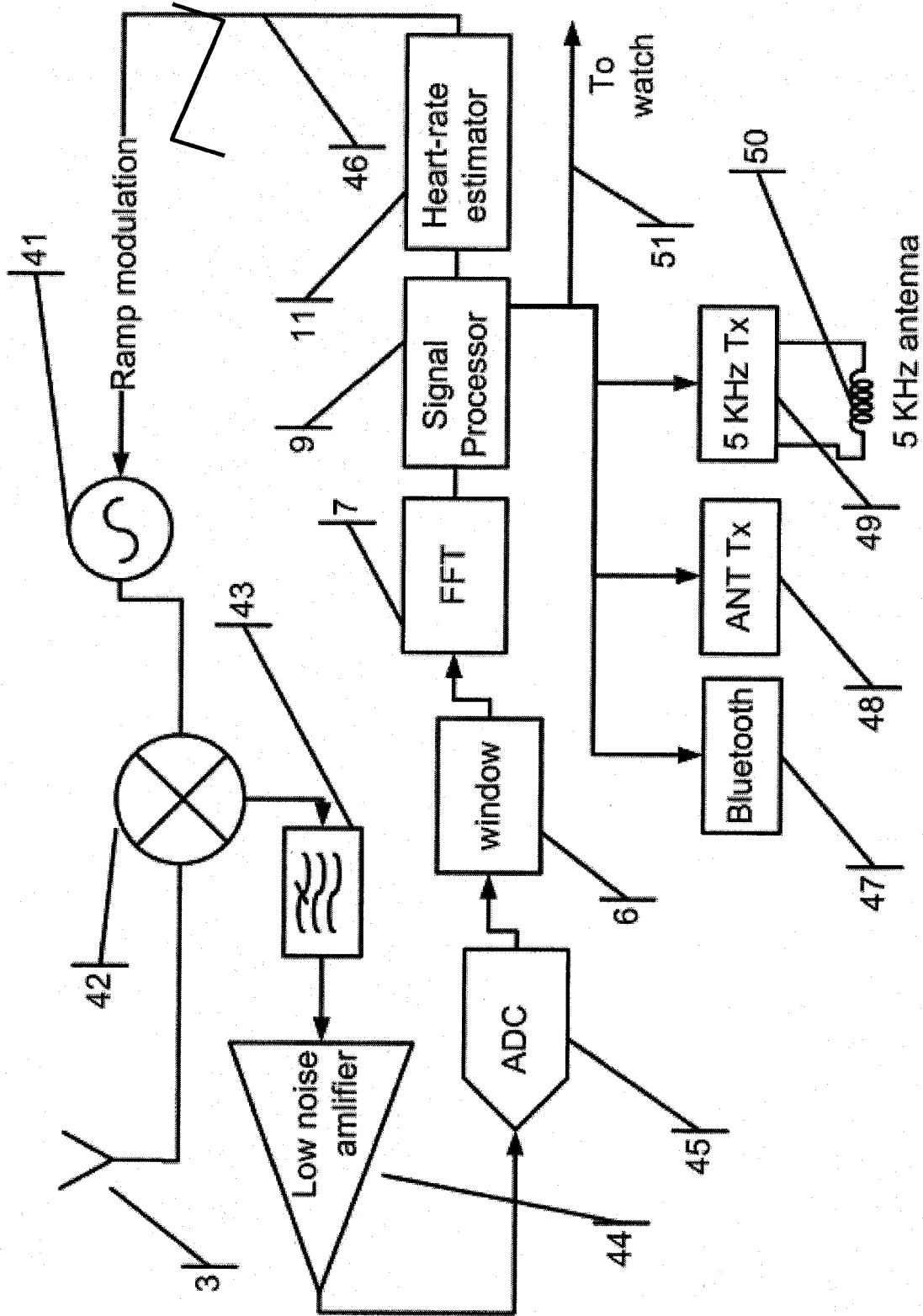

Fig. 5

HRM detection using crossing

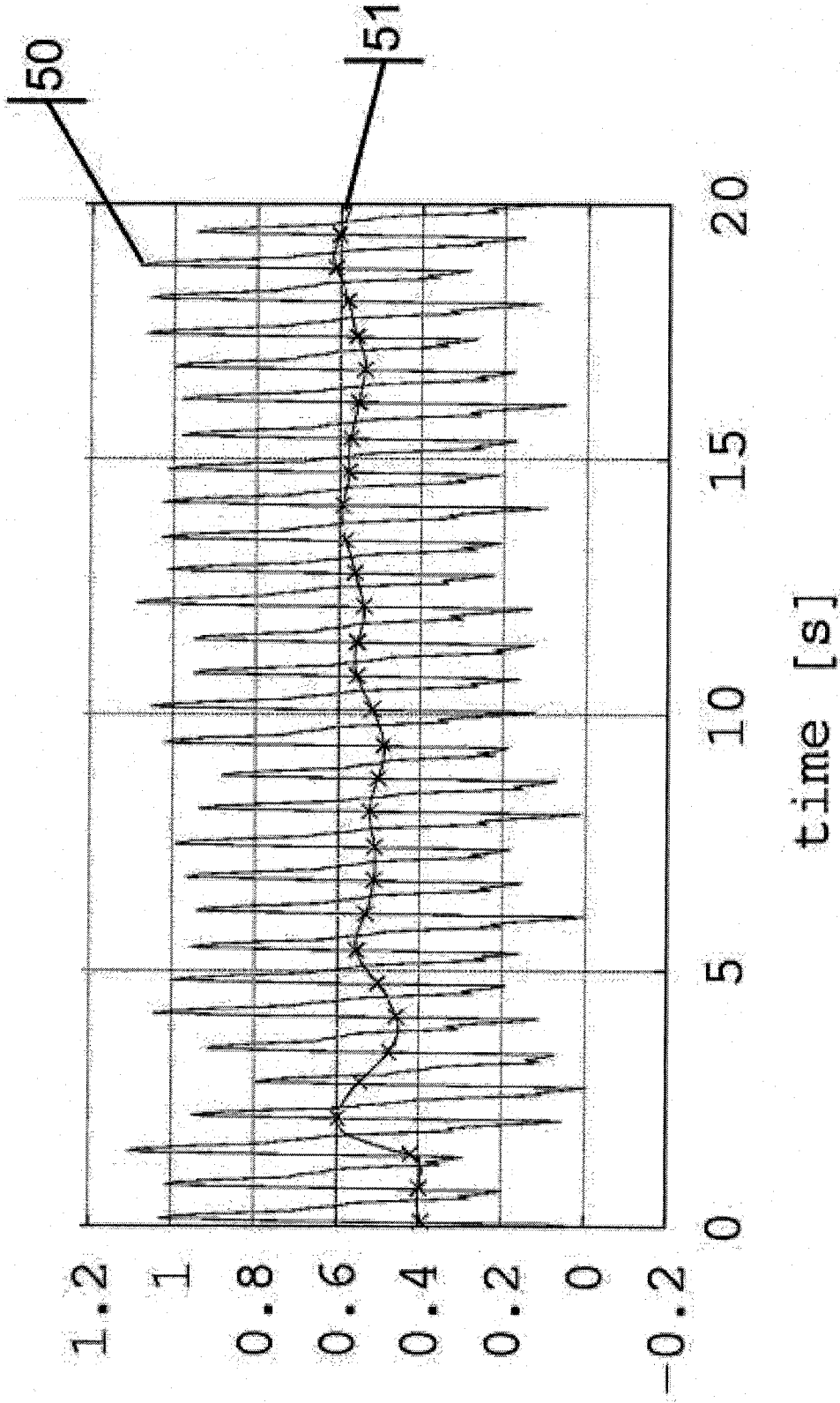

Fig. 6

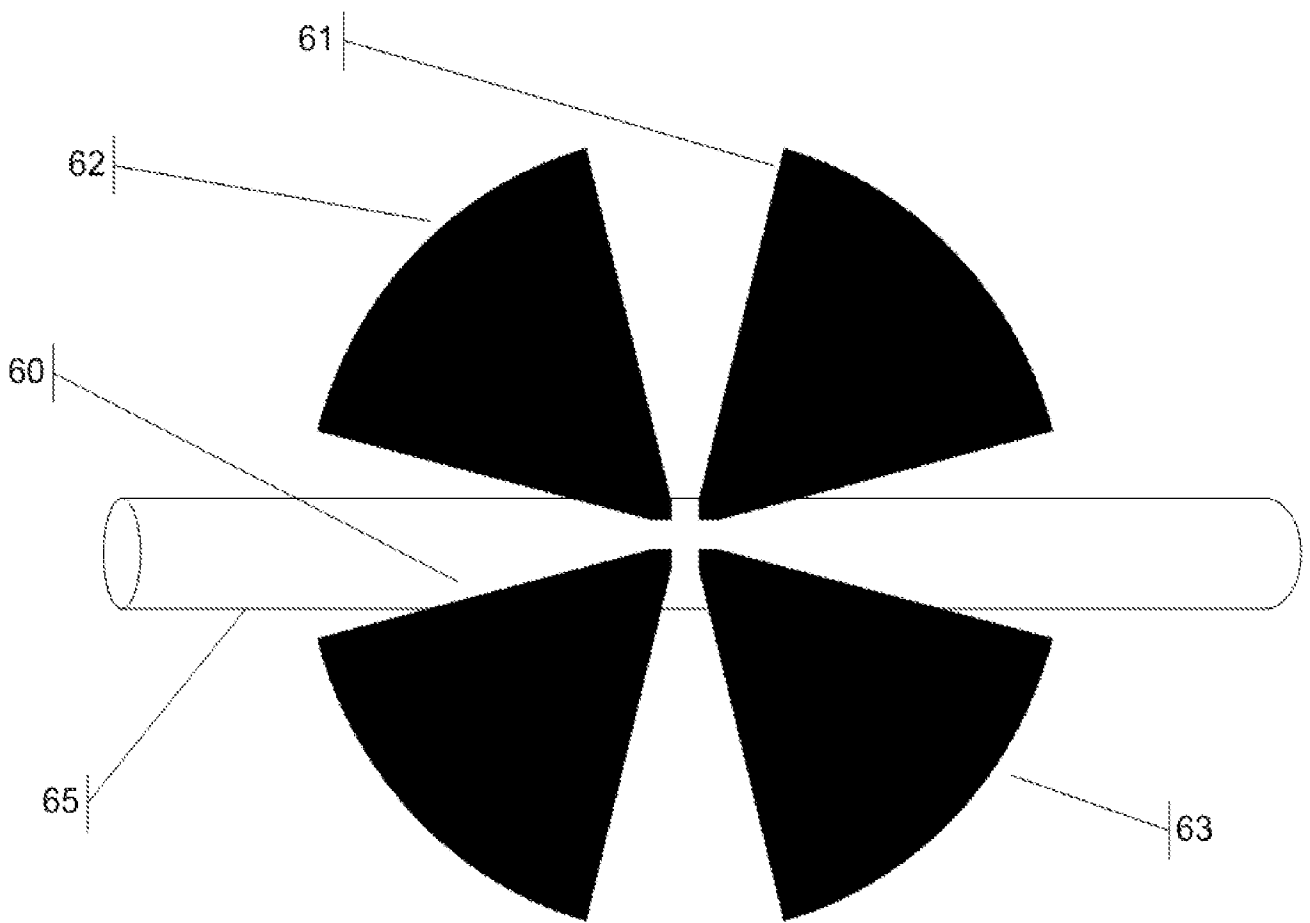

Fig. 7

INTERNATIONAL SEARCH REPORT

International application No.

PCT/IL2013/050113

A. CLASSIFICATION OF SUBJECT MATTER IPC (2013.01) A61B 6/00, A61B 5/024500, G01S 13/34		
According to International Patent Classification (IPC) or to both national classification and IPC		
B. FIELDS SEARCHED		
Minimum documentation searched (classification system followed by classification symbols) IPC (2013.01) A61B 6/00		
Documentation searched other than minimum documentation to the extent that such documents are included in the fields searched		
Electronic data base consulted during the international search (name of data base and, where practicable, search terms used) Databases consulted: THOMSON INNOVATION, Esp@cenet, Google Patents, Google Scholar		
C. DOCUMENTS CONSIDERED TO BE RELEVANT		
Category*	Citation of document, with indication, where appropriate, of the relevant passages	Relevant to claim No.
X	US 2010027737 A1 Mostov 04 Feb 2010 (2010/02/04) (The whole document)	1-7,19,37
X	JP 2005 102959 A KOBAYASHI MICHIO 21 Apr 2005 (2005/04/21) (The whole document)	1,4-6,10,12,27,32, 33,35,37
Y	WO 2009067627 A1 Mostov 28 May 2009 (2009/05/28) (Figs. 1, 9-11, paragraphs 35, 37-39, 70-76)	1-7,19,37
Y	US 5361070 A McEwan. 01 Nov 1994 (1994/11/01) (abstract, Fig. 1)	9
<input checked="" type="checkbox"/> Further documents are listed in the continuation of Box C. <input checked="" type="checkbox"/> See patent family annex.		
* Special categories of cited documents: "A" document defining the general state of the art which is not considered to be of particular relevance "E" earlier application or patent but published on or after the international filing date "L" document which may throw doubts on priority claim(s) or which is cited to establish the publication date of another citation or other special reason (as specified) "O" document referring to an oral disclosure, use, exhibition or other means "P" document published prior to the international filing date but later than the priority date claimed "T" later document published after the international filing date or priority date and not in conflict with the application but cited to understand the principle or theory underlying the invention "X" document of particular relevance; the claimed invention cannot be considered novel or cannot be considered to involve an inventive step when the document is taken alone "Y" document of particular relevance; the claimed invention cannot be considered to involve an inventive step when the document is combined with one or more other such documents, such combination being obvious to a person skilled in the art "&" document member of the same patent family		
Date of the actual completion of the international search 11 Jun 2013		Date of mailing of the international search report 18 Jun 2013
Name and mailing address of the ISA; Israel Patent Office Technology Park, Bldg.5, Malcha, Jerusalem, 9695101, Israel Facsimile No. 972-2-5651616		Authorized officer NIMER Emad Telephone No. 972-2-5657801

INTERNATIONAL SEARCH REPORT

International application No.

PCT/IL2013/050113

C (Continuation). DOCUMENTS CONSIDERED TO BE RELEVANT		
Category*	Citation of document, with indication, where appropriate, of the relevant passages	Relevant to claim No.
Y	"A 1.3V 26mW 3.2Gs/s undersampled LC bandpass ADC for a SDR ISMband receiver in 130nm CMOS," in Proc. IEEE Radio Frequency Integrated Circuits Symposium, (RFIC'09), June 2009, pp. 383-386. Beilleau et al. 01 Jun 2009 (2009/06/01) (title, abstract)	7
Y	WO 98/16846 A Tullsson et al. 23 Apr 1998 (1998/04/23) (abstract, page 1 line 30-page 2 line 4, Figs. 1-6)	7
Y	WO 00/75687 A1 Magnus et al. 14 Dec 2000 (2000/12/14) (abstract, page 13, lines 4-11)	8
Y	"A 77 GHz 90 nm CMOS Transceiver for FMCW Radar Applications, IEEE Journal of Solid-State Circuits", Vol. 45, NO. 4, April 2010. Toshiya Mitomo et al. 01 Apr 2010 (2010/04/01) (abstract, Figs. 1-4, 8, pages 928-931)	9,11,13-16
Y	US 201 1304497 A1 Molyneux et al. 15 Dec 2011 (2011/12/15) (par. 60, Figs. 2A, 2B)	36
Y	US 6028563 A Higgins. 22 Feb 2000 (2000/02/22) (abstract, Fig. 1, claims 10, 11)	17,31
Y	US 7893886 B2 Schadler. 22 Feb 2011 (2011/02/22) (abstract, Figs. 1-4, col. 1 lines 15-18)	18
Y	EP 2290392 A1 MHill et al. 02 Mar 2011 (2011/03/02) (abstract, window 610, par. 26)	20
Y	US 2010179438 A1 Heneghan et al. 15 Jul 2010 (2010/07/15) (abstract, Figs. 1, 2, 6, 7)	1-23,27-37
A	US 2010198083 A1 Lin et al. 05 Aug 2010 (2010/08/05) (abstract, Figs. 1, 3A, 4, 5D, 8A, 11, 16, 17)	1-37

INTERNATIONAL SEARCH REPORT
Information on patent family members

International application No.
PCT/IL2013/050113

Patent document cited search report	Publication date	Patent family member(s)	Publication Date
US 2010027737 A1	04 Feb 2010	EP 2210126 A1	28 Jul 2010
		EP 2210126 A4	31 Aug 2011
		US 2010027737 A1	04 Feb 2010
		US 8115472 B2	14 Feb 2012
		US 2012105048 A1	03 May 2012
		WO 2009055728 A1	30 Apr 2009
JP 2005 102959 A	21 Apr 2005	JP 2005 102959 A	21 Apr 2005
WO 2009067627 A1	28 May 2009	EP 2223 152 A1	01 Sep 2010
		EP 2223 152 A4	20 Apr 2011
		US 2012229322 A1	13 Sep 2012
		US 8334703 B2	18 Dec 2012
		WO 2009067627 A1	28 May 2009
US 5361070 A	01 Nov 1994	AT 214853 T	15 Apr 2002
		AT 217977 T	15 Jun 2002
		AT 219252 T	15 Jun 2002
		AT 233904 T	15 Mar 2003
		AT 278969 T	15 Oct 2004
		AU 3499995 A	27 Mar 1996
		AU 4742296 A	10 Jul 1996
		AU 6249396 A	24 Dec 1996
		AU 6376696 A	16 Oct 1996
		AU 6684496 A	05 Mar 1997
		AU 6842196 A	05 Mar 1997
		AU 6905494 A	12 Dec 1994
		CA 2160351 A1	27 Oct 1994
		CA 2160351 C	04 Apr 2006
		CA 2160352 A1	27 Oct 1994
		CA 2160352 C	10 Jan 2006

INTERNATIONAL SEARCH REPORT
Information on patent family members

International application No.
PCT/IL2013/050113

Patent document cited search report	Publication date	Patent family member(s)	Publication Date
	CA 2162257	A1	24 Nov 1994
	CA 2162257	C	27 Dec 2005
	CA 2199120	A1	14 Mar 1996
	CA 2199120	C	08 May 2007
	CA 2208070	A1	27 Jun 1996
	CA 2208070	C	29 Jul 2008
	CA 2215506	A1	03 Oct 1996
	CA 2215506	C	19 May 2009
	CA 2223756	A1	12 Dec 1996
	CA 2223756	C	20 Jan 2009
	CA 2503382	A1	27 Oct 1994
	CA 2605339	A1	27 Oct 1994
	CA 2605339	C	30 Sep 2008
	CN 1173226	A	11 Feb 1998
	CN 115 1382	C	26 May 2004
	DE 69425373	D1	31 Aug 2000
	DE 69425373	T2	22 Feb 2001
	DE 69430195	D1	25 Apr 2002
	DE 69430195	T2	24 Oct 2002
	DE 69430801	D1	18 Jul 2002
	DE 69430801	T2	16 Jan 2003
	DE 69434064	D1	11 Nov 2004
	DE 69434064	T2	06 Oct 2005
	DE 6952565 1	D1	04 Apr 2002
	DE 6952565 1	T2	10 Oct 2002
	DE 69529830	D1	10 Apr 2003
	DE 69529830	T2	20 Nov 2003
	DE 6962133 1	D1	27 Jun 2002
	DE 6962133 1	T2	09 Jan 2003
	DE 69623481	D1	10 Oct 2002
	DE 69623481	T2	20 Feb 2003

INTERNATIONAL SEARCH REPORT
Information on patent family members

International application No.
PCT/IL2013/050113

Patent document cited search report	Publication date	Patent family member(s)	Publication Date
	DE 69627488	D1	22 May 2003
	DE 69627488	T2	24 Dec 2003
	EP 0694171	A1	31 Jan 1996
	EP 0694171	A4	17 Apr 1996
	EP 0694171	B1	20 Mar 2002
	EP 0694235	A1	31 Jan 1996
	EP 0694235	A4	17 Apr 1996
	EP 0694235	B1	12 Jun 2002
	EP 0700528	A1	13 Mar 1996
	EP 0700528	A4	29 Jan 1997
	EP 0700528	B1	26 Jul 2000
	EP 0779990	A1	25 Jun 1997
	EP 0779990	A4	25 Aug 1999
	EP 0779990	B1	05 Mar 2003
	EP 0799428	A1	08 Oct 1997
	EP 0799428	A4	11 Mar 1998
	EP 0799428	B1	27 Feb 2002
	EP 0829020	A2	18 Mar 1998
	EP 0829020	A4	08 Jul 1998
	EP 0829020	B1	22 May 2002
	EP 0830566	A1	25 Mar 1998
	EP 0830566	A4	03 Nov 1999
	EP 0830566	B1	16 Apr 2003
	EP 0842440	A1	20 May 1998
	EP 0842440	A4	30 Sep 1998
	EP 0842440	B1	04 Sep 2002
	EP 1178330	A1	06 Feb 2002
	EP 1178330	B1	06 Oct 2004
	ES 2174874	T3	16 Nov 2002
	JP H085 11341	A	26 Nov 1996
	JP 3471803	B2	02 Dec 2003

INTERNATIONAL SEARCH REPORT
Information on patent family members

International application No.
PCT/IL2013/050113

Patent document cited search report	Publication date	Patent family member(s)	Publication Date
		JP H085091 10 A	24 Sep 1996
		JP 3573747 B2	06 Oct 2004
		JP 2004004100 A	08 Jan 2004
		JP 3648236 B2	18 May 2005
		JP H09500960 A	28 Jan 1997
		JP 3701968 B2	05 Oct 2005
		JP H105 11182 A	27 Oct 1998
		JP 3891359 B2	14 Mar 2007
		JP 2006047322 A	16 Feb 2006
		JP 3897803 B2	28 Mar 2007
		JP HI 1503229 A	23 Mar 1999
		JP 4015 191 B2	28 Nov 2007
		JP H10505671 A	02 Jun 1998
		JP 4195506 B2	10 Dec 2008
		JP HI 1506825 A	15 Jun 1999
		US 5345471 A	06 Sep 1994
		US 5361070 A	01 Nov 1994
		US 5361070 B1	16 May 2000
		US 5457394 A	10 Oct 1995
		US 55 10800 A	23 Apr 1996
		US 55 12834 A	30 Apr 1996
		US 55 17198 A	14 May 1996
		US 55 19400 A	21 May 1996
		US 5523760 A	04 Jun 1996
		US 5576627 A	19 Nov 1996
		US 5589838 A	31 Dec 1996
		US 5661490 A	26 Aug 1997
		US 5757320 A	26 May 1998
		US 5767953 A	16 Jun 1998
		US 5774091 A	30 Jun 1998
		US 5805 110 A	08 Sep 1998

INTERNATIONAL SEARCH REPORT
Information on patent family members

International application No.
PCT/IL2013/050113

Patent document cited search report	Publication date	Patent family member(s)	Publication Date
		WO 9424579 A1	27 Oct 1994
		WO 9424788 A1	27 Oct 1994
		WO 9427168 A1	24 Nov 1994
		WO 9607928 A1	14 Mar 1996
		WO 9619737 A1	27 Jun 1996
		WO 9630771 A2	03 Oct 1996
		WO 9630771 A3	21 Nov 1996
		WO 9639612 A1	12 Dec 1996
		WO 9705760 A2	20 Feb 1997
		WO 9705760 A3	03 Apr 1997
		WO 9706447 A1	20 Feb 1997
<hr/>			
WO 98/16846 A	23 Apr 1998	NONE	
<hr/>			
WO 00/75687 A1	14 Dec 2000	NONE	
<hr/>			
US 201 1304497 A1	15 Dec 201 1	CA 2743 188 A1	10 Jun 2010
		CA 2744209 A1	10 Jun 2010
		CA 2762500 A1	29 Jun 2012
		CN 102341 149 A	01 Feb 2012
		CN 102369046 A	07 Mar 2012
		CN 202538303 U	21 Nov 2012
		EP 2370186 A2	05 Oct 201 1
		EP 2370187 A1	05 Oct 201 1
		EP 2472288 A1	04 Jul 2012
		JP 2012139493 A	26 Jul 2012
		JP 20125 10873 A	17 May 2012
		JP 20125 10876 A	17 May 2012
		KR 20120076418 A	09 Jul 2012
		US 2010184563 A1	22 Jul 2010
		US 8172722 B2	08 May 2012

INTERNATIONAL SEARCH REPORT
Information on patent family members

International application No.
PCT/IL2013/050113

Patent document cited search report	Publication date	Patent family member(s)	Publication Date
		US 201 1304497 A1	15 Dec 201 1
		US 823 1506 B2	31 Jul 2012
		US 2010184564 A1	22 Jul 2010
		US 2012191405 A1	26 Jul 2012
		US 2012262329 A1	18 Oct 2012
		US 2013 130843 A1	23 May 2013
		WO 2010065836 A2	10 Jun 2010
		WO 2010065836 A3	29 Jul 2010
		WO 2010065886 A1	10 Jun 2010
US 6028563 A	22 Feb 2000	AU 730484 B2	08 Mar 2001
		AU 7399798 A	2 1 Jan 1999
		CA 22401 14 A1	03 Jan 1999
		DE 19829714 A1	2 1 Jan 1999
		DE 19829714 B4	20 Apr 2006
		NZ 330858 A	29 Jun 1999
		SE 9802352 DO	0 1 Jul 1998
		SE 9802352 A	04 Jan 1999
		SE 9802352 L	04 Jan 1999
		US 6028563 A	22 Feb 2000
US 7893886 B2	22 Feb 201 1	US 2006033672 A1	16 Feb 2006
		US 7081860 B2	25 Jul 2006
		US 2006033670 A1	16 Feb 2006
		US 7893886 B2	22 Feb 201 1
EP 2290392 A1	02 Mar 201 1	EP 2290392 A1	02 Mar 201 1
		JP 201 1039033 A	24 Feb 201 1
		US 201 1037643 A1	17 Feb 201 1
		US 8179305 B2	15 May 2012

INTERNATIONAL SEARCH REPORT
Information on patent family members

International application No.
PCT/IL2013/050113

Patent document cited search report	Publication date	Patent family member(s)	Publication Date
US 2010179438 A1	15 Jul 2010	AU 20073 17469 A1	15 May 2008
		AU 20073 17469 B2	20 May 2010
		CA 2668400 A1	15 May 2008
		CA 2668400 C	15 May 2012
		CN 101689219 A	31 Mar 2010
		EP 2078270 A2	15 Jul 2009
		EP 2078270 A4	02 Dec 2009
		EP 2469436 A2	27 Jun 2012
		EP 2469436 A3	18 Jul 2012
		JP 2010508128 A	18 Mar 2010
		US 2010179438 A1	15 Jul 2010
		WO 2008057883 A2	15 May 2008
		WO 2008057883 A3	31 Jul 2008
US US2010198083 A1	05 Aug 2010	NONE	

专利名称(译)	微波非接触式心率传感器		
公开(公告)号	EP2811908A1	公开(公告)日	2014-12-17
申请号	EP2013746312	申请日	2013-02-07
[标]申请(专利权)人(译)	SENSIFREE		
申请(专利权)人(译)	SENSIFREE LTD.		
当前申请(专利权)人(译)	SENSIFREE LTD.		
[标]发明人	BARAK ILAN SAUL		
发明人	BARAK, ILAN SAUL		
IPC分类号	A61B6/00 A61B5/0245 G01S13/34 A61B5/00 A61B5/024 A61B5/026 A61B5/05 G01S13/58 G01S13/88		
CPC分类号	A61B5/0507 A61B5/02444 A61B5/026 A61B5/681 G01S13/583 G01S13/88		
优先权	61/597734 2012-02-11 US		
其他公开文献	EP2811908A4		
外部链接	Espacenet		

摘要(译)

一种用于检测人或动物受试者中每单位长度变化的动脉血流量的心率传感器，其包括用于感测待测量的受试者的动脉中的血液的瞬时体积的天线；RADAR单元，用于将微波信号传输到受试者身体部位或肢体中，代表组织目标。RADAR单元的输出包括信号的叠加，每个信号对应于具有与目标的反射强度相关的幅度的不同组织目标；用于将反射信号转换为数字的采样电路；窗函数电路，用于抑制源自后续处理器的不需要的频谱边带，该后续处理器对时间截断数据进行操作；跟随窗函数电路的FFT处理器，用于根据其相对频率将叠加分成多个区间，每个区间的幅度代表距天线特定距离处的目标的反射幅度；信号处理器，用于滤除传感器相对于身体部位的运动或身体部位的运动的影响，并用于产生信号，其幅度与表示心率的动脉变化的扩张成比例；心率估计器，用于测量动脉扩张变化的频率，并用于消除不是来自动脉的任何信号的幅度干扰；用于为传感器供电的电池。