



- (51) International Patent Classification:  
A61B 5/00 (2006.01)
- (21) International Application Number:  
PCT/IB2012/050671
- (22) International Filing Date:  
14 February 2012 (14.02.2012)
- (25) Filing Language:  
Italian
- (26) Publication Language:  
English
- (30) Priority Data:  
VI2011A000027 14 February 2011 (14.02.2011) IT
- (71) Applicants (for all designated States except US): **ALEXANDRE, Antonio** [IT/IT]; Via Nuova, 9, I-88100 Catanzaro (CZ) (IT). **ALEXANDRE, Alvisè** [IT/IT]; Via Nuova, 9, I-88100 Catanzaro (CZ) (IT). **ALEXANDRE, Andrea** [IT/IT]; Via San Nicolò, 5/B, I-31100 Treviso (TV) (IT).

- (72) Inventor; and
- (75) Inventor/Applicant (for US only): **ALEXANDRE, Alberto** [IT/IT]; Via San Nicolò 5/B, I-31100 Treviso (TV) (IT).
- (74) Agent: **MAROSCIA, Antonio**; Maroscia & Associati S.r.l., Contrà Porti, 21, I-36100 Vicenza (IT).
- (81) Designated States (unless otherwise indicated, for every kind of national protection available): AE, AG, AL, AM, AO, AT, AU, AZ, BA, BB, BG, BH, BR, BW, BY, BZ, CA, CH, CL, CN, CO, CR, CU, CZ, DE, DK, DM, DO, DZ, EC, EE, EG, ES, FI, GB, GD, GE, GH, GM, GT, HN, HR, HU, ID, IL, IN, IS, JP, KE, KG, KM, KN, KP, KR, KZ, LA, LC, LK, LR, LS, LT, LU, LY, MA, MD, ME, MG, MK, MN, MW, MX, MY, MZ, NA, NG, NI, NO, NZ, OM, PE, PG, PH, PL, PT, QA, RO, RS, RU, RW, SC, SD, SE, SG, SK, SL, SM, ST, SV, SY, TH, TJ, TM, TN, TR, TT, TZ, UA, UG, US, UZ, VC, VN, ZA, ZM, ZW.
- (84) Designated States (unless otherwise indicated, for every kind of regional protection available): ARIPO (BW, GH, GM, KE, LR, LS, MW, MZ, NA, RW, SD, SL, SZ, TZ, UG, ZM, ZW), Eurasian (AM, AZ, BY, KG, KZ, MD, RU,

[Continued on next page]

(54) Title: MULTI - SENSOR DEVICE FOR TREATMENT AND REMOTE MONITORING OF VITAL BIOLOGICAL PARAMETERS

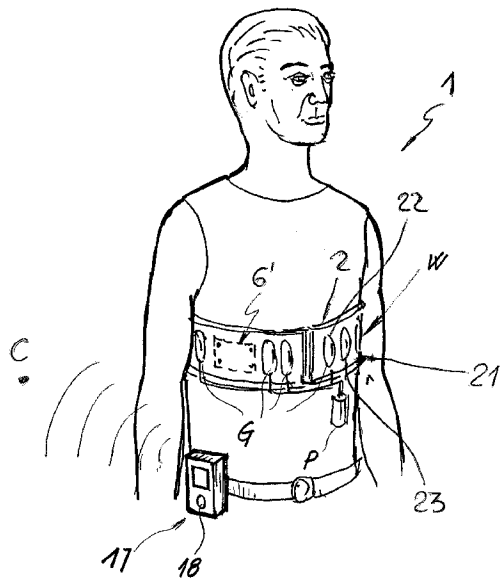

FIG. 1

(57) Abstract: A portable multi-sensor device (1 ) comprises a substantially sheet-like and at least partially flexible unit support element (2), a garment (W) designed to be worn by a user and to be removably associated with the unit element (2), a plurality of sensors (S), adapted to detect biological and/or vital parameters on the body of a user and transduce them into electric signals, at least one of which is incorporated in the unit support element (2), transceiver means (6) for remote transmission of the electric signals to a remote monitoring center (C), processing and control means (6') for processing and controlling the associated electric signals, therapeutic treatment means (21 ) associated with the unit support element (2) and designed to contact one part of the wearer's body. The therapeutic treatment means (21 ) are electrically connected to the processing and control means (6') to be controlled thereby and to provide therapeutic and/or thermal therapeutic treatment to the area of the body with which they are in contact.



TJ, TM), European (AL, AT, BE, BG, CH, CY, CZ, DE, DK, EE, ES, FI, FR, GB, GR, HR, HU, IE, IS, IT, LT, LU, LV, MC, MK, MT, NL, NO, PL, PT, RO, RS, SE, SI, SK, SM, TR), OAPI (BF, BJ, CF, CG, CI, CM, GA, GN, GQ, GW, ML, MR, NE, SN, TD, TG).

**Published:**

- *with international search report (Art. 21(3))*
- *before the expiration of the time limit for amending the claims and to be republished in the event of receipt of amendments (Rule 48.2(h))*

## MULTI-SENSOR DEVICE FOR TREATMENT AND REMOTE MONITORING OF VITAL BIOLOGICAL PARAMETERS

Field of the invention

5           The present invention generally finds application in the field of electromedical equipment and particularly relates to a multi-sensor device for remote detection of biological and vital parameters, for remote diagnosis in patients, elderly or people undergoing remote analysis and examination.

          A further aspect of the invention relates to a remote monitoring system  
10 in patients and users in general, which incorporates such device.

Background art

          Devices have been long known for remote monitoring and diagnosis of bioelectric, biological, neuro-orthopedic and functional parameters, such as heartbeat rate, respiratory rate, body temperature, position and balance in  
15 elderly individuals with particular devices, or in users in general to be monitored for a given time.

          These physiological and vital parameters and signs may be subject to remote monitoring, i.e. detection and storage by a control unit located next to the patient, and then transmitted via radio, telephone or the Internet to a  
20 diagnostics service center, such as Holter devices for ECG recording in active individuals.

          The control unit typically has an emergency button which is used to send an alarm signal to a local receiving station (in most cases such receiving station being located in the user's house) and which transmits it to  
25 a service center.

          This system has a satisfactory operation as long as the user can accomplish his/her tasks by his/herself, and is nearly useless if the patient feels faint or has an accident.

          Vital sign detection devices are known, e.g. resembling large watches  
30 containing a number of sensors therein, such as a motion sensor (accelerometer) for detecting any fall, an optical cell located at an aperture

where the user periodically places his/her finger, if he/she can do it, for heartbeat detection, a finger plethysmograph for measuring oxygen in blood, a pushbutton for emergency calls.

5 With this system, proper detection and monitoring of parameters entirely relies on the patient. Also in this case, if the user feels faint, the fall alarm might only be useful. Nevertheless, since the device is locally placed on the wrist, i.e. the part of the body that is most exposed to abrupt movements, rotations and bends, this alarm would also be ineffective.

10 Other prior art remote monitoring devices are disclosed, for instance, in US6551252, WO03/034890, US4827943, US6656125, US6047203, US7173437, WO2010/038176, US2011/087080, WO2009/036329, US2005/096513. The devices disclosed in these prior art documents are designed to be worn for a rather long time and essentially consist of a corset or a chest belt, which is much more comfortable and reliable.

15 Another commercially available type of such devices consists of garments, such as t-shirts, belts or corsets having sensors integrated in a fabric and associated with an electronic remote control circuit, as disclosed, for instance, in WO2005032447.

20 Measurements performed with these prior art devices have proven poor reliability. This is because electrodes and sensors typically comprise a conductive yarn, e.g. woven silver threads. Nevertheless, once the garment has been washed a few times, metal fibers separate from the base fabric and uncomfortably contact the skin. Furthermore, especially elderly or ill users are reluctant to wear the garment, which shall be rather close-fitting for easy  
25 acquisition of biological data.

One general drawback of prior art detection devices is that they cannot provide a real-time therapeutic action to the patient, at the area of the body upon which they are worn.

30 A further drawback of these detection devices is their poor portability by users and the difficulty to adapt them to garments. The user is often an

working place, and would find it uncomfortable and inconvenient to use a rigid and complex apparatus.

Furthermore, these devices cannot be easily modified or adapted to particular conditions of use, e.g. with a light garment, or a garment used for  
5 leisure time.

#### Disclosure of the invention

A main object of the present invention is to obviate the above drawbacks, by providing a remote vital and biological parameter monitoring device that is highly efficient and relatively cost-effective.

10 A particular object is to provide a Multi-sensor therapeutic device that affords monitoring of vital signs of a patient and real-time intervention on the patient with a therapeutic action, modulated according to the detected parameters.

A further object is to provide a device for monitoring biometric and vital  
15 parameters, that can be more easily and comfortably worn as compared with prior art bustiers, belts, corsets, with improved wearability by users, possibly elderly people, who have just undergone surgery or have problems in moving.

Yet another object is to provide a device for monitoring biometric and  
20 vital parameters that can be adapted to various types and forms of garments, for more flexible use by active individuals.

These and other objects, as better explained hereafter, are fulfilled by a device as defined in claim 1, which comprises at least one plurality of sensors adapted to detect one or more biological and/or vital parameters on  
25 the body of a user and transduce them into analog electric signals, processing and control means for turning said analog electric signals into digital electric signals, means for remote transmission of these digital signals to a remote monitoring center. The device is characterized in that this plurality of sensors and these processing and control means are incorporated  
30 in a substantially sheet-like and at least partially flexible unit support element, which is adapted to be removably associated with a belt, a corset or a

garment designed to be worn by a user, so that at least some of these sensors directly contact his/her body.

With this particular configuration, the device may be easily associated with a common or special garment, without requiring any change thereto and  
5 while affording high flexibility and easy application.

Such device allows remote monitoring of the user in any part of the world, and also allows detection of their position in case of elderly and socially disadvantaged users.

In a second aspect, the invention relates to a system for remote  
10 monitoring of patients and users which, as defined in claim 12, comprises a garment adapted to be worn by a user, which is removably coupled to a portable Multi-sensor device for remote electronic monitoring of biological and vital parameters as defined in claim 1, such Multi-sensor device being adapted to be associated with an external GPRS/GPS module for remote  
15 connection of the device to a remote monitoring center.

With this system, the user that wears it may be continuously monitored 24 hours a day, by direct connection to a monitoring center.

Advantageous embodiments of the invention are described in the dependent claims.

20 Brief description of the drawings

Further features and advantages of the invention will be more readily apparent upon reading of the detailed description of a preferred non-exclusive embodiment of a Multi-sensor device for remote electronic monitoring of biological and vital parameters, which is shown as a non-  
25 limiting example with the help of the annexed figures, in which:

FIG. 1 is a general perspective view that diagrammatically shows a device of the invention associated with a garment worn by a user;

FIG. 2 is a top perspective view of a device of the invention;

FIG. 3 is a bottom perspective view of the device of FIG. 2.

30 Detailed description of one preferred embodiment

Referring to the accompanying figures, the device of the invention,

generally designated by numeral 1, may be used for remotely monitoring a general user and for providing a physical therapy to the area of the body of the user where the device is applied from time to time.

As shown in Fig. 1, the device essentially comprises a support  
5 element 2 with a plurality of sensors, generally referenced S, attached thereto, for detecting biological and/or vital parameters on the body of a user and for transducing them into electric signals, as described in greater detail hereinafter.

The device further comprises processing and control means 6' for  
10 detecting and processing the electric signals generated by the sensors S.

The processing and control means 6' are associated with the unit support element 2 in a stationary or removable fashion, e.g. are incorporated therein.

Preferably, the device 1 comprises a garment W adapted to be worn  
15 by a user, such as a bustier, a corset, a t-shirt or any other garment having means for removable attachment thereto of the unit element 2, with the processing and control means 6' entirely integrated therein.

Preferably, the processing and control means 6' comprise a relatively  
20 thin sheet-like card 3, which is at least partially flexible and/or deformable, and adapted to conform to the outer surface of the user's body.

Conveniently, the card 3 has a front surface 3' and a rear surface 3'' which are substantially parallel, and have the plan shape and size of a credit card, e.g. 40x30x3 mm.

The sensors S are attached to the front surface 3' to be oriented  
25 towards the user's body and generate respective analog and/or digital electric signals, as described in greater detail below. Preferably, the above mentioned surface 3', which is designed to contact the user's skin, is covered by a layer of soft and biocompatible material to avoid irritation.

Advantageously, the device 1 also comprises means 21 for  
30 therapeutic treatment of the area of the human body in contact with the device 1, which are associated with the support element 2 and are designed

to contact a part of the user's body.

The therapeutic treatment means 21 are electrically connected to the processing and control means 6' to be controlled thereby and to provide, for instance, an orthopedic and/or thermal therapeutic treatment to the area of  
5 the body with which they are in contact.

The processing and control means 6' may include a printed circuit board 4 placed on the front surface 3' of the card 3, and connected with the sensors S and other electronic components, essentially consisting of electronic circuits 5 for processing and control of the electric signals  
10 generated by the sensors S and for conversion thereof into digital electric signals, as well as means for remote transmission of the digital signals to a remote monitoring center, schematically designated as C.

Furthermore, the therapeutic treatment means 21 may include at least one first electrode 22, preferably two first electrodes 22, which are adapted to  
15 contact the part of the human body to provide a predetermined voltage and cause a transcutaneous electrostimulation of such region of the body.

Particularly, the first electrodes 22 may be designed to generate a plurality of electrical pulses at skin level, which are designed to interact with the muscular tissue for electrostimulation thereof.

The frequency and duration of application of such pulses may be  
20 adjusted by the processing and control means 6' according to the type of treatment to be administered to the user.

Conveniently, the therapeutic treatment means 21 may include at least one second electrode 23, which is adapted to contact an additional area of  
25 the human body and release heat thereto for thermotherapy.

Particularly, the second electrode 23 may operate with an electrical resistor, infrared rays, Peltier effect, magnetic and/or electromagnetic fields or the like.

Furthermore, the processing and control means 6' may supply power  
30 to the second electrode 22 in a continuous or discontinuous manner, according to the treatment to be administered to the user.

In a particularly advantageous aspect of the invention, the processing and control means 6' may simultaneously supply power to the first electrodes 22 and the second electrode 23 for providing thermal therapy and electrostimulation at the same time.

5 Suitably, the first electrodes 22 and the second electrode 23 may be formed from the same base material.

Such base material may exhibit good electrical and thermal conductivity, to allow conduction of the electric signals transmitted by the processing and control means 6' and release of large amounts of heat.

10 Particularly, the base material may be selected from the group of conductive fabrics, namely composite conductive fabrics such as carbon fiber fabrics.

Advantageously, the garment W may have respective seats for stable and possibly removable accommodation of the electrodes 21, 22.

15 The garment W to be worn by a user is selected from the group comprising a belt, a bustier, a corset, an undershirt, a t-shirt, a glove, trousers, and has interface means for removable attachment thereof to the unit element 2.

20 Preferably, a garment W in the form of a bustier or corset may include orthopedic treatment means, such as air chambers G adapted to be inflated by an electric compressor P, for compression or distraction of the rib cage or the pelvis.

Conveniently, the compressor P is of such a size as to allow integration thereof in the garment W.

25 A non-limiting description of the sensors S is provided below, although sensors may be of many types, according to the type of user/patient to be monitored.

For example, the sensors S may comprise:

- a heartbeat and rate detector,
- 30 - a respiratory rhythm and rate detector,
- a blood oxygen saturation detector,

- a body temperature detector,
- a step counter,
- a position and motion sensor,
- a fall sensor.

5           The above mentioned sensors may be integrated in the belt-like unit element 2 and/or wearable garment W in such a manner that the device 1 may operate at least partially even when the user wears only one of the element 2 and the garment W.

10           The heart rate and rhythm detector 7 may consist of a pair of flexible silver woven conductive electrodes or a layer of conductive silicone rubber, not shown.

15           The blood oxygen content sensor may consist of a reflective optical device 8, which processes the light reflected by the skin and the light reflected by the underlying tissues, to determine the amount of oxygen therein.

            Possibly, the signal emitted by the optical device 8 may be processed to determine the interval between two reflected fluxes and hence the heartbeat rate. As a result, the blood oxygen saturation sensor and the heart rate sensor can be combined in a single optical device 8.

20           The breath detector, not shown, may use a piezoelectric or resistive elastomer as a sensitive element, which is adapted to generate an electric signal or a resistance variation in response to a deformation caused by a user's breath.

25           The temperature sensor 9 may consist of a sensor-chip comprising a thermistor sensitive to body temperature, which may be placed in direct contact with the user's skin.

            The motion sensor 10 may consist of an acceleration sensor (MEMS) capable of detecting accelerations along the three Cartesian axes and may be also used as a fall sensor.

30           The analog electric signals generated by the sensors S are transmitted to the processing and control means 6', which essentially comprise a

programmable microprocessor (EPROM) 11, to be converted into stable digital signals. The microprocessor 11 is programmed to set periodic sampling of all biometric and vital parameters to be monitored and to calculate mathematical and statistic data, such as the mean, the mean-square deviation, the variance of detected values.

Finally, an area of the microprocessor is dedicated to a mass storage (RAM) 11' for data storage and retrieval by the control system.

Terminals 12, 13 are provided at the ends of the electronic circuit 4, and are in turn connected to the terminals of a rechargeable battery 14, preferably placed on the rear surface 3" of the card 3.

The remote transmission means 6 for remote transmission of digital signals may include a transceiver or transponder 15 connected to a transceiving antenna 16.

Furthermore, the transceiver means 6 may be designed to transmit and receive the electric signals to and from display and interface means 24.

The display and interface means 24 may be a portable electronic apparatus, such as a remote control, a computer, a smartphone, a tablet or the like.

Particularly, the display and interface means 24 may be of wireless type to receive the electric signals transmitted by the transceiver means 6.

The display and interface means may be designed to display the received electric signals on a display or the like and allow the user to introduce biological data.

Such biological data may be transmitted to the transceiver means 6 which may in turn send it to the processing and control means 6' as soon as they receive it.

The biological data may be processed by the microprocessor 11 and later saved in the mass storage 11'.

Furthermore, such processing of the biological data by the processor 11, may change the power signals supplied to the therapeutic treatment means to change the action of the first electrode and/or second electrode.

The transponder 15 may be integrated in the card 3 or contained in an intermediate unit, located in an external container 17, like in FIG. 1, which resembles a portable telephone, and may be carried by the user and possibly held in a pocket or attached to a belt, and may transfer data via phone over a GPRS line. An emergency button 18 may be possibly provided on the container 17, to be actuated by the user when needed.

As an alternative, the card 3 with the processing and control means 6 may be integrated in the garment W or comprise removable anchor means for removably joining it to the garment W.

Such anchor means may consist of snap fasteners 19 arranged along the corners of the card 3, or Velcro® straps 20 fixed along the end edges of the card 3.

Of course, these anchor means may be replaced by other means, such as adhesives or magnetic plates, not shown.

With these anchor means, the card 3 and hence the device 1 as a whole, may be removably joined to any garment W or a bustier, a belt F or a corset.

The operation of the device 1 is as follows.

In a continuous fashion, or at predetermined time intervals, the microprocessor controls the sequential and periodic sampling of all parameters, i.e. heartbeat, body temperature, motion, oxygen saturation, step count, and any fall. These parameters are temporarily stored in the RAM storage 11' of the microprocessor 11. Statistic data is calculated at regular intervals, and periodically loaded and retrieved to and from the internal storage 11'.

A USB port may be possibly provided in the circuit 4, for connecting the microprocessor to a portable storage medium such as a pen drive, which may store the data to be directly transferred to a PC.

Should an alarm condition occur, the signal processed by the microprocessor 11 or possibly generated by pushing the emergency button on the container 17, will be immediately transmitted, in addition to the space

coordinates of the transmitter worn by the user, by the transponder 15 over a GPRS line to the remote service center C, which will allow actions to be taken according to predetermined protocols.

5 Furthermore, a remote control or a similar device may be used to act upon the electric control circuits of the electrodes 21, 22, to provide an electrostimulation therapy and/or a thermal therapy, possibly with regular intervals being set to provide such therapies.

The service center C may request all stored data at any time, or download it from each user at a predetermined time, e.g. midnight.

10 In a second aspect, the invention relates to a system for remote monitoring of patients and users which comprises a garment adapted to be worn by a user, and to be removably joined to the above described portable Multi-sensor device, which may be in turn associated with an external GPRS/GPS module 17 for remote connection to a remote monitoring center  
15 C.

The device and the system of the invention are susceptible of many changes and variants within the inventive principle disclosed in the annexed claims.

20 All the details thereof may be replaced by other technically equivalent parts, and the materials may vary depending on different needs, without departure from the scope of the invention.

25 While the device and system have been described with particular reference to the annexed figures, the numerals referred to in the disclosure and claims are only used for the sake of a better intelligibility of the invention and shall not be intended to limit the claimed scope in any manner.

## CLAIMS

1. A portable multi-sensor device (1) for treatment and remote monitoring of vital biological parameters:
- 5           - a garment (W) designed to be worn by a user;
- a substantially sheet-like and at least partially flexible unit support element (2), adapted to be removably joined to said garment (W);
- a plurality of sensors (S), adapted to detect biological and/or vital parameters on the body of a user and transduce them into electric signals, at least one of said sensors (S) being incorporated in said unit support element
- 10           (2);
- transceiver means (6) for remote transmission of said electric signals to a remote monitoring center (C);
- processing and control means (6') for processing and controlling
- 15           said electric signals associated with said unit support element (2);
- characterized by comprising therapeutic treatment means (21) associated with said unit support element (2) and designed to come into contact with a part of the user's body, said therapeutic treatment means (21) being electrically connected to said processing and control means (6') to be
- 20           controlled thereby and to provide therapeutic and/or thermal therapeutic treatment to the area of the body with which they are in contact.

2. Multi-sensor device as claimed in claim 1, characterized in that said therapeutic treatment means (21) include at least one, preferably two
- 25           first electrostimulating electrodes (22), which are adapted to contact respective areas of the user's body to provide a predetermined voltage for transcutaneous electrostimulation of such areas of the body.

3. Multi-sensor device as claimed in claim 2, characterized in that
- 30           said first electrodes (22) are adapted to generate a plurality of electrical pulses at skin level, for electrostimulation of muscular tissues in the body

region to be treated.

4. Multi-sensor device as claimed in claim 1 or 2, characterized in that said therapeutic treatment means (21) include at least one second  
5 electrode (23) adapted to contact an additional area of the user's body to release heat thereto for thermotherapy.

5. Multi-sensor device as claimed in claim 3 or 4, characterized in that said at least one second electrode (23) is of the electrical resistor type,  
10 infrared rays, Peltier effect, magnetic and/or electromagnetic fields type or the like.

6. Multi-sensor device as claimed in claims 3 to 5, characterized in that said first electrodes (22) and said second electrode (23) are made of a  
15 base material selected from the group comprising the conductive composite fabrics with carbon fiber.

7. Multi-sensor device as claimed in claim 6, characterized by comprising a garment adapted to be worn by a user and having means for  
20 removable attachment of said unit element thereto, and a plurality of seats for stably accommodating said electrodes.

8. Multi-sensor device as claimed in claim 7, characterized in that said garment is selected from the group comprising a belt, a bustier, a corset,  
25 an undershirt, a t-shirt, a sweater, a glove, trousers.

9. Multi-sensor device as claimed in claim 7 or 8, characterized in that said wearable garment comprises orthopedic treatment means, such as  
inflatable air chambers (G) for distraction of the rib cage or the pelvis.

30

10. Multi-sensor device as claimed in claim 9, characterized in that

said orthopedic treatment means comprise a compressor integrated in said wearable garment (W).

11. Multi-sensor device as claimed in any preceding claim,  
5 characterized in that said processing and control means (6') comprise a card (3) made of a relatively flexible synthetic material, which is adapted to conform to the outer surface of the user's body and approximately has a polygonal plan shape and a predetermined size.

10 12. Multi-sensor device as claimed in claim 11, characterized in that said processing and control means (6') are integrated in said wearable garment (W).

13. Multi-sensor device as claimed in claim 11, characterized in that  
15 said card (3) comprises removable anchor means (19, 20) for removable anchoring thereof to a belt, a bustier or a garment (W), wherein said anchor means are selected from the group comprising buttons, Velcro, contact or magnetic adhesives.

20 14. Multi-sensor device as claimed in any claim 11 to 13, characterized in that some of said sensors (S) are anchored to said card (3) on its front surface (3'), to face the user's body, and are possibly covered by a protective layer of soft and biocompatible material, to avoid skin irritation of the user's epidermis, the others of said sensors (S) being anchored to said  
25 sheet-like unit element (2).

15. Multi-sensor device as claimed in any preceding claim, characterized in that said sensors (S) comprise at least one heart rate and rhythm detector (7) and at least one respiratory rate and rhythm detector.

30

16. Multi-sensor device as claimed in any preceding claim,

characterized in that said sensors (S) comprise at least one blood oxygen content detector(8).

17. Multi-sensor device as claimed in any preceding claim,  
5 characterized in that said sensors (S) comprise at least one temperature sensor (9).

18. Multi-sensor device as claimed in any preceding claim,  
10 characterized in that said sensors include at least one position and motion detector (10).

19. Multi-sensor device as claimed in any preceding claim,  
characterized in that said transceiver means (6) include at least one wireless transceiver or transponder (15) and a transceiving antenna (16).

15  
20. Multi-sensor device as claimed in any preceding claim,  
characterized in that said transceiver means (6) are adapted to transmit and receive said electric signals to and from display and interface means (24).

20  
21. A device as claimed in claim 20, characterized in that said display and interface means (24) are of wireless type, to receive said electric signals from said transceiver means (6), said display and interface means (24) being adapted to display said electric signals on a display or the like, allow a user to enter biological data and transmit said biological data to said  
25 transceiver means (6).

22. A device as claimed in claim 21, characterized in that said processing and control means (6') include at least one programmable microprocessor (11) connected to said sensors (S) and/or to said therapeutic  
30 treatment means (21) and containing at least one mass storage (11') for storing said electric signals and said biological data transmitted by said

display and interface means (24), said at least one microprocessor (11) being connected to a rechargeable battery (14).

23. A device as claimed in any claim from 11 to 22, characterized in  
5 that said transceiver means (6) are integrated in said card (3) or are installed in an intermediate portable unit (17) adapted to be worn by a user and electrically connected with said processing and control means (6') and said therapeutic treatment means (21), said intermediate unit (17) having  
10 GPRS/GPS transmission and localization means and possibly an emergency button (18).

24. A system for remote monitoring of patients and users, comprising a garment (W) adapted to be worn by a user, which is designed to be removably joined to a portable Multi-sensor device (1) for remote electronic  
15 monitoring of biological and vital parameters as claimed in one or more of the preceding claims, said Multi-sensor device (1) being adapted to be associated with an external GPRS/GPS module (17) for remote connection to a remote monitoring center.

1/2

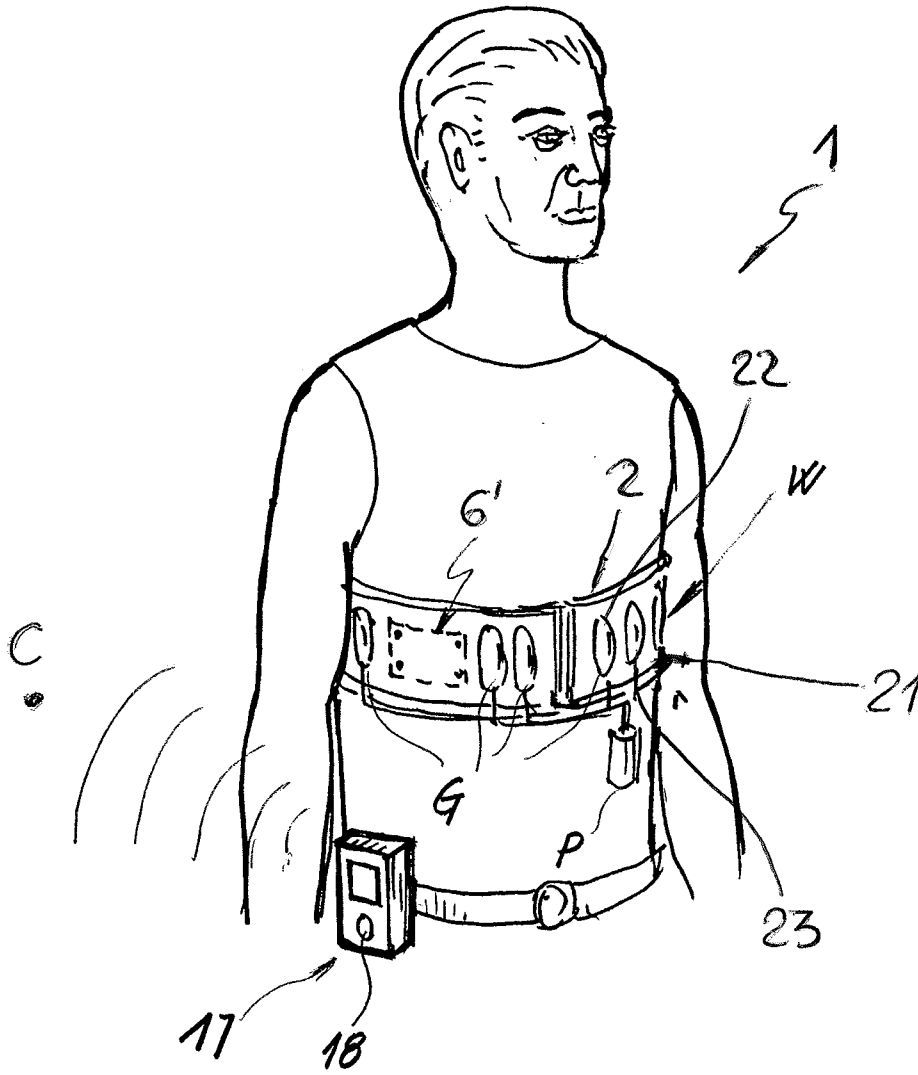

FIG. 1

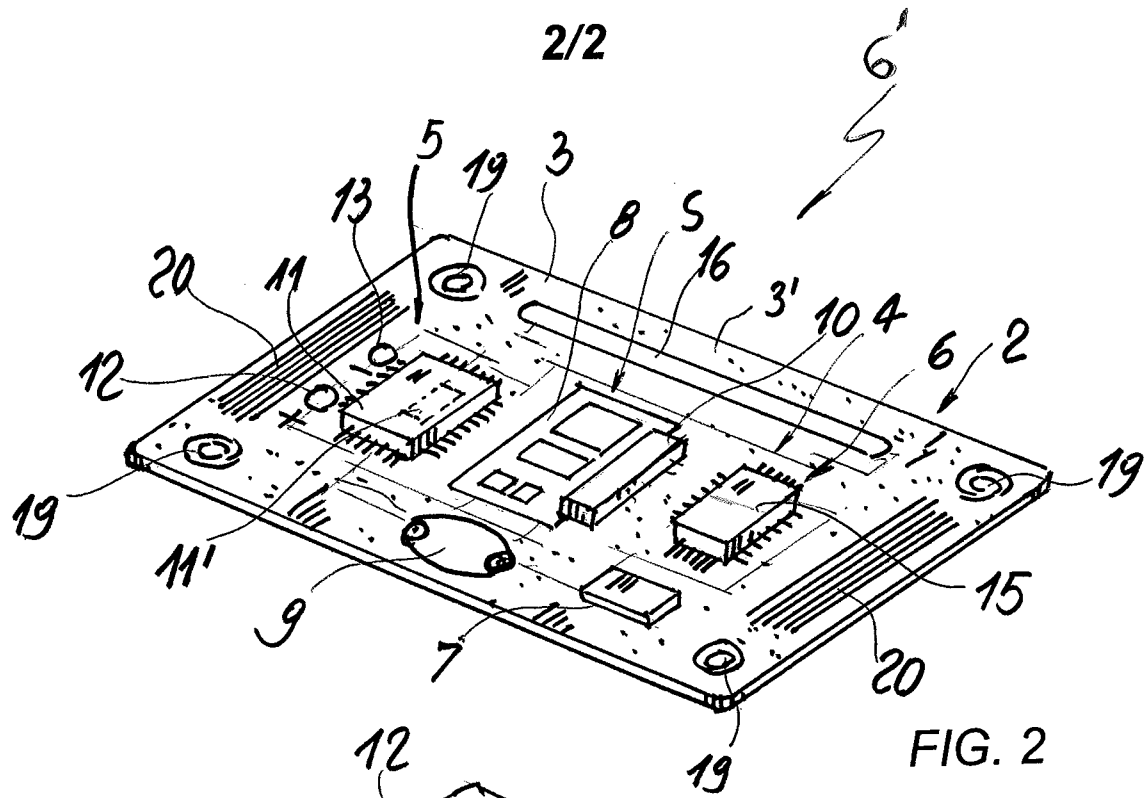

FIG. 2

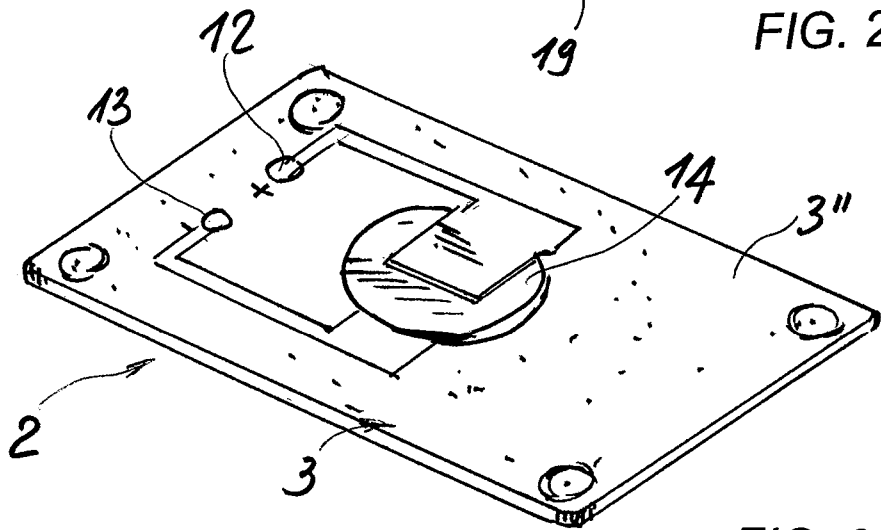

FIG. 3

**INTERNATIONAL SEARCH REPORT**

International application No  
PCT/IB2012/050671

| <b>A. CLASSIFICATION OF SUBJECT MATTER</b><br>INV. A61B5/00<br>ADD.   |   |  |
|---|---|--|
| According to International Patent Classification (IPC) or to both national classification and IPC   |   |  |
| <b>B. FIELDS SEARCHED</b>   |   |  |
| Minimum documentation searched (classification system followed by classification symbols)<br>A61B A41D A61N   |   |  |
| Documentation searched other than minimum documentation to the extent that such documents are included in the fields searched   |   |  |
| Electronic data base consulted during the international search (name of data base and, where practicable, search terms used)<br>EPO-Internal, WPI Data  |   |  |
| <b>C. DOCUMENTS CONSIDERED TO BE RELEVANT</b>   |   |  |
| Category*   | Citation of document, with indication, where appropriate, of the relevant passages  | Relevant to claim No.  |
| X   | US 2010/286545 A1 (WOLFE ANDREW [US] ET AL) 11 November 2010 (2010-11-11)<br>figures 1-3<br>paragraphs [0024], [0025], [0030], [0035], [0037] - [0047], [0057], [0069], [0083]  | 1-24   |
| X   | -----<br>WO 2009/153730 A2 (KONINKL PHILIPS ELECTRONICS NV [NL]; VAN DEN EERENBEEMD JACOBUS M A [N]) 23 December 2009 (2009-12-23)<br>figures 1a,1b<br>page 4, line 14 - line 26<br>page 5, line 32 - line 34<br>page 6, line 8 - line 14<br>page 8, line 3 - line 4<br>-----<br>-/-- | 1-24   |
| <input checked="" type="checkbox"/> Further documents are listed in the continuation of Box C. <input checked="" type="checkbox"/> See patent family annex.   |   |  |
| * Special categories of cited documents :<br>"A" document defining the general state of the art which is not considered to be of particular relevance<br>"E" earlier application or patent but published on or after the international filing date<br>"L" document which may throw doubts on priority claim(s) or which is cited to establish the publication date of another citation or other special reason (as specified)<br>"O" document referring to an oral disclosure, use, exhibition or other means<br>"P" document published prior to the international filing date but later than the priority date claimed<br>"T" later document published after the international filing date or priority date and not in conflict with the application but cited to understand the principle or theory underlying the invention<br>"X" document of particular relevance; the claimed invention cannot be considered novel or cannot be considered to involve an inventive step when the document is taken alone<br>"Y" document of particular relevance; the claimed invention cannot be considered to involve an inventive step when the document is combined with one or more other such documents, such combination being obvious to a person skilled in the art<br>"&" document member of the same patent family |   |  |
| Date of the actual completion of the international search<br><br>29 June 2012   |   | Date of mailing of the international search report<br><br>06/07/2012 |
| Name and mailing address of the ISA/<br>European Patent Office, P.B. 5818 Patentlaan 2<br>NL - 2280 HV Rijswijk<br>Tel. (+31-70) 340-2040,<br>Fax: (+31-70) 340-3016  |   | Authorized officer<br><br>Vanderperren, Yves                         |

**INTERNATIONAL SEARCH REPORT**

International application No  
PCT/IB2012/050671

C(Continuation). DOCUMENTS CONSIDERED TO BE RELEVANT

| Category* | Citation of document, with indication, where appropriate, of the relevant passages  | Relevant to claim No. |
|-----------|---|-----------------------|
| X,P       | DE 20 2011 107065 U1 (JANSSEN BENEDIKT [DE]) 7 December 2011 (2011-12-07) paragraphs [0001] - [0004] claims 1-3<br>-----  | 1-24                  |
| X         | US 2010/063556 A1 (OESTREICH WOLFGANG [DE]) 11 March 2010 (2010-03-11) figure 1 paragraphs [0013], [0032] - [0035], [0037], [0044], [0045]<br>-----   | 1-24                  |
| X         | WO 02/40091 A2 (GEORGIA TECH RES INST [US]; JAYARAMAN SUNDARESAN [US]; PARK SUNGMEE [U]) 23 May 2002 (2002-05-23) figure 2 page 2, line 24 - page 4, line 17 page 9, line 4 - line 7<br>----- | 1-24                  |
| A         | US 2010/094146 A1 (COULSTON GEORGE W [US] ET AL MICKA THOMAS A [US] ET AL) 15 April 2010 (2010-04-15) figure 1 paragraphs [0050], [0057] - [0058]<br>-----                                    | 9,10                  |

**INTERNATIONAL SEARCH REPORT**

Information on patent family members

|   |
|---|
| International application No<br>PCT/IB2012/050671 |
|---|

| Patent document cited in search report | Publication date | Patent family member(s) | Publication date              |
|--|------------------|-------------------------|-------------------------------|
| US 2010286545                          | A1               | 11-11-2010              | NONE                          |
| -----                                  |                  |                         |                               |
| WO 2009153730                          | A2               | 23-12-2009              | CN 102065757 A 18-05-2011     |
|  |                  |                         | EP 2291115 A2 09-03-2011      |
|  |                  |                         | JP 2011524774 A 08-09-2011    |
|  |                  |                         | KR 20110020925 A 03-03-2011   |
|  |                  |                         | US 2011087300 A1 14-04-2011   |
|  |                  |                         | WO 2009153730 A2 23-12-2009   |
| -----                                  |                  |                         |                               |
| DE 202011107065                        | U1               | 07-12-2011              | NONE                          |
| -----                                  |                  |                         |                               |
| US 2010063556                          | A1               | 11-03-2010              | AR 068180 A1 11-11-2009       |
|  |                  |                         | AU 2008231863 A1 02-10-2008   |
|  |                  |                         | CA 2681216 A1 02-10-2008      |
|  |                  |                         | CN 101678207 A 24-03-2010     |
|  |                  |                         | DE 102007014136 A1 02-10-2008 |
|  |                  |                         | EP 2136879 A2 30-12-2009      |
|  |                  |                         | JP 2010522584 A 08-07-2010    |
|  |                  |                         | KR 20090123963 A 02-12-2009   |
|  |                  |                         | RU 2009139079 A 27-04-2011    |
|  |                  |                         | TW 200901932 A 16-01-2009     |
|  |                  |                         | US 2010063556 A1 11-03-2010   |
|  |                  |                         | WO 2008116822 A2 02-10-2008   |
| -----                                  |                  |                         |                               |
| WO 0240091                             | A2               | 23-05-2002              | AU 1981402 A 27-05-2002       |
|  |                  |                         | CA 2428884 A1 23-05-2002      |
|  |                  |                         | CN 1486159 A 31-03-2004       |
|  |                  |                         | EP 1341441 A2 10-09-2003      |
|  |                  |                         | JP 2004513711 A 13-05-2004    |
|  |                  |                         | MX PA03004169 A 02-12-2004    |
|  |                  |                         | US 6970731 B1 29-11-2005      |
|  |                  |                         | WO 0240091 A2 23-05-2002      |
| -----                                  |                  |                         |                               |
| US 2010094146                          | A1               | 15-04-2010              | AU 2004270270 A1 17-03-2005   |
|  |                  |                         | AU 2004289182 A1 26-05-2005   |
|  |                  |                         | BR PI0414255 A 07-11-2006     |
|  |                  |                         | CA 2537530 A1 17-03-2005      |
|  |                  |                         | CA 2537586 A1 26-05-2005      |
|  |                  |                         | CN 1863482 A 15-11-2006       |
|  |                  |                         | CN 1863484 A 15-11-2006       |
|  |                  |                         | EP 1662985 A1 07-06-2006      |
|  |                  |                         | EP 1662991 A2 07-06-2006      |
|  |                  |                         | EP 1662999 A1 07-06-2006      |
|  |                  |                         | JP 4473271 B2 02-06-2010      |
|  |                  |                         | JP 4623742 B2 02-02-2011      |
|  |                  |                         | JP 4660480 B2 30-03-2011      |
|  |                  |                         | JP 2007504911 A 08-03-2007    |
|  |                  |                         | JP 2007509242 A 12-04-2007    |
|  |                  |                         | JP 2007518459 A 12-07-2007    |
|  |                  |                         | KR 20070024452 A 02-03-2007   |
|  |                  |                         | KR 20070045139 A 02-05-2007   |
|  |                  |                         | US 2005106977 A1 19-05-2005   |
|  |                  |                         | US 2005118914 A1 02-06-2005   |
|  |                  |                         | US 2005277837 A1 15-12-2005   |
|  |                  |                         | US 2007293750 A1 20-12-2007   |
|  |                  |                         | US 2008177188 A1 24-07-2008   |
|  |                  |                         | US 2010094146 A1 15-04-2010   |
|  |                  |                         | US 2010198086 A1 05-08-2010   |

# INTERNATIONAL SEARCH REPORT

Information on patent family members

International application No

PCT/IB2012/050671

| Patent document cited in search report | Publication date | Patent family member(s) | Publication date |
|--|------------------|-------------------------|------------------|
|  |                  | US 2010198113 A1        | 05-08-2010       |
|  |                  | WO 2005023104 A2        | 17-03-2005       |
|  |                  | WO 2005025414 A1        | 24-03-2005       |
|  |                  | WO 2005046476 A1        | 26-05-2005       |
|  |                  |                         |                  |

|                |   |         |            |
|----------------|---|---------|------------|
| 专利名称(译)        | 多传感器装置，用于治疗 and 远程监测重要的生物学参数  |         |            |
| 公开(公告)号        | <a href="#">EP2675344A1</a>   | 公开(公告)日 | 2013-12-25 |
| 申请号            | EP2012711236  | 申请日     | 2012-02-14 |
| [标]申请(专利权)人(译) | ALEXANDRE ANTONIO<br>ALEXANDRE Alvisè酒店<br>ALEXANDRE ANDREA   |         |            |
| 申请(专利权)人(译)    | ALEXANDRE , ANTONIO<br>ALEXANDRE , Alvisè酒店<br>ALEXANDRE , ANDREA   |         |            |
| 当前申请(专利权)人(译)  | ALEXANDRE , ANTONIO<br>ALEXANDRE , Alvisè酒店<br>ALEXANDRE , ANDREA   |         |            |
| [标]发明人         | ALEXANDRE ALBERTO   |         |            |
| 发明人            | ALEXANDRE, ALBERTO  |         |            |
| IPC分类号         | A61B5/00  |         |            |
| CPC分类号         | A61B5/0022 A61B5/02438 A61B5/0816 A61B5/11 A61B5/14552 A61B5/6804 A61B2562/164 G16H40/67 A61N2/002 A61N5/0625 |         |            |
| 代理机构(译)        | MAROSCIA , ANTONIO  |         |            |
| 优先权            | 102011901916056 2011-02-14 IT   |         |            |
| 其他公开文献         | EP2675344B1   |         |            |
| 外部链接           | <a href="#">Espacenet</a>   |         |            |

#### 摘要(译)

一种便携式多传感器装置 ( 1 ) 包括基本上为片状且至少部分柔性的单元支撑元件 ( 2 ) , 设计成由使用者穿着并且可拆卸地与单元元件 ( 2 ) 相关联的衣服 ( W ) , 适于检测用户身体上的生物和/或生命参数并将它们转换成电信号的多个传感器 ( S ) , 其中至少一个被并入单元支撑元件 ( 2 ) 中, 收发器装置 ( 6 ) , 用于将电信号远程传输到远程监视中心 ( C ) , 用于处理和控制相关联的电信号的处理和控制装置 ( 6&#39; ) , 与单元支撑元件 ( 2 ) 相关联的治疗处理装置 ) 并且设计成接触穿着者身体的一部分。治疗处理装置 ( 21 ) 电连接到要被控制的处理和控制装置 ( 6&#39; ) , 并且对它们所接触的身体区域提供治疗和/或热治疗处理。