

(19) World Intellectual Property Organization
International Bureau



(43) International Publication Date
28 July 2011 (28.07.2011)

(10) International Publication Number
WO 2011/088571 A1

(51) International Patent Classification:

G01N 21/64 (2006.01) *A61K 49/00* (2006.01)
A61B 5/00 (2006.01) *G01N 21/55* (2006.01)
A61K 41/00 (2006.01) *G01N 33/52* (2006.01)

(21) International Application Number:

PCT/CA2011/000090

(22) International Filing Date:

25 January 2011 (25.01.2011)

(25) Filing Language:

English

(26) Publication Language:

English

(30) Priority Data:

61/297,969 25 January 2010 (25.01.2010) US

(71) Applicant (for all designated States except US): **UNIVERSITY HEALTH NETWORK** [CA/CA]; 190 Elizabeth Street, R. Fraser Elliott Building, Room 1S-417, Toronto, Ontario M5G 2C4 (CA).

(72) Inventors; and

(75) Inventors/Applicants (for US only): **KIM, Anthony Taywon** [CA/CA]; 110-55 Ellerslie Avenue, Toronto, Ontario M2N 1X9 (CA). **WILSON, Brian Campbell** [CA/CA]; 85 Indian Grove, Toronto, Ontario M6R 2Y6 (CA).

(74) Agents: **NORTON ROSE OR LLP/S.E.N.C.R.L., s.r.l.** et al.; Suite 2500, 1 Place Ville Marie, Montreal, Québec H3B 1R1 (CA).

(81) Designated States (unless otherwise indicated, for every kind of national protection available): AE, AG, AL, AM, AO, AT, AU, AZ, BA, BB, BG, BH, BR, BW, BY, BZ, CA, CH, CL, CN, CO, CR, CU, CZ, DE, DK, DM, DO, DZ, EC, EE, EG, ES, FI, GB, GD, GE, GH, GM, GT, HN, HR, HU, ID, IL, IN, IS, JP, KE, KG, KM, KN, KP, KR, KZ, LA, LC, LK, LR, LS, LT, LU, LY, MA, MD, ME, MG, MK, MN, MW, MX, MY, MZ, NA, NG, NI, NO, NZ, OM, PE, PG, PH, PL, PT, RO, RS, RU, SC, SD, SE, SG, SK, SL, SM, ST, SV, SY, TH, TJ, TM, TN, TR, TT, TZ, UA, UG, US, UZ, VC, VN, ZA, ZM, ZW.

(84) Designated States (unless otherwise indicated, for every kind of regional protection available): ARIPO (BW, GH, GM, KE, LR, LS, MW, MZ, NA, SD, SL, SZ, TZ, UG, ZM, ZW), Eurasian (AM, AZ, BY, KG, KZ, MD, RU, TJ, TM), European (AL, AT, BE, BG, CH, CY, CZ, DE, DK, EE, ES, FI, FR, GB, GR, HR, HU, IE, IS, IT, LT, LU, LV, MC, MK, MT, NL, NO, PL, PT, RO, RS, SE, SI, SK, SM, TR), OAPI (BF, BJ, CF, CG, CI, CM, GA, GN, GQ, GW, ML, MR, NE, SN, TD, TG).

Published:

— with international search report (Art. 21(3))

(54) Title: DEVICE, SYSTEM AND METHOD FOR QUANTIFYING FLUORESCENCE AND OPTICAL PROPERTIES

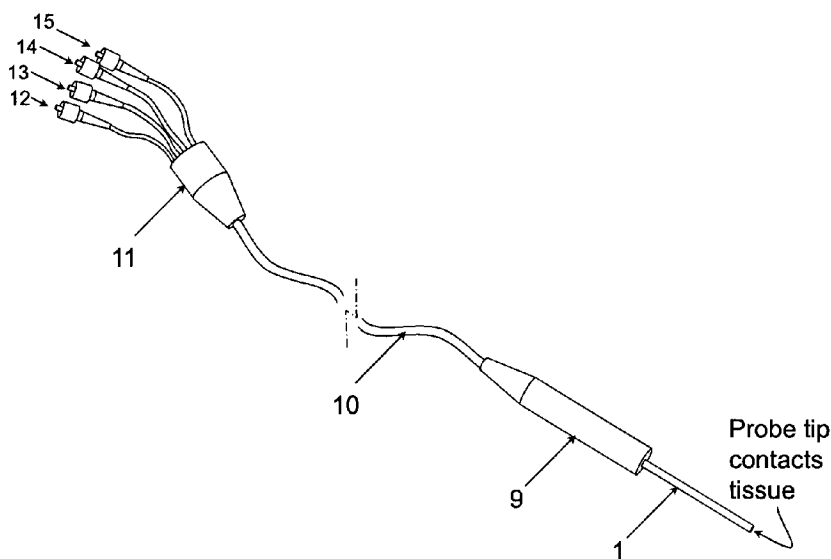

FIG. 1

(57) Abstract: Methods for quantifying fluorescence and optical properties in a turbid medium such as tissue. Devices and systems suitable for the methods are also disclosed.



WO 2011/088571 A1

DEVICE, SYSTEM AND METHOD FOR QUANTIFYING FLUORESCENCE AND OPTICAL PROPERTIES

Cross-Reference to Related Applications

[0001] The present disclosure claims priority from U.S. Provisional Patent Application No. 61/297,969, filed January 25, 2010, the entirety of which is hereby incorporated by reference.

Technical Field

[0002] The present disclosure relates to devices for quantifying fluorescence and optical properties. In particular, the present disclosure relates to probe devices and methods for quantifying fluorescence in an optically turbid medium, such as tissue, using optical properties measurements.

Background

[0003] The present disclosure is related to fluorescence imaging and spectroscopy, in particular the use of fluorescence to detect and/or treat cancer by marking tumor cells with an appropriate fluorescing agent. One difficulty in using fluorescence for medical diagnostics and therapeutics is quantifying the fluorescence in tissue. Fluorescence signals are strongly affected by variations in the tissue absorption and transport scattering properties (*i.e.* tissue optical properties), whereas often the objective is to quantify the fluorescence based on fluorophore concentration alone.

[0004] Fluorescence measurement is of interest for applications such as photosensitizer dosimetry during photodynamic therapy (Finlay *et al.* 2006), fluorescence image-guided surgery (Stummer *et al.* 1998), detection of cancerous or dysplastic lesions (Muller *et al.*, 2001) and in time kinetics studies of fluorescing drugs (Sroka *et al.* 1996). The shape and intensity of the fluorescence spectrum contain useful information on the identity and abundance of fluorophores in tissue. However, accuracy of quantitative fluorescence measurement is complicated by the distorting effects of light absorption and scattering by the tissue and the variations in measurement geometry (*e.g.* detector-to-tissue surface distance). Untangling these confounding effects is important for quantitative analysis of fluorescence.

[0005] Some methods have been developed in an attempt to diminish these distorting effects to better utilize fluorescence information. Many of these techniques use a diffuse reflectance signal to correct the fluorescence signal from optical properties variation. Wu and coworkers have developed a fluorescence photon migration model to produce a relation with the diffuse reflectance that can be exploited to extract the quantitative fluorescence in tissue (Wu *et al.* 1993). On a different tack, a single optical fiber may be used for both source and collection, the concept being that detectable fluorescence events occur so close to the fiberoptic tip that absorption and scattering effects are minimal, analogous to how these effects are minimal for very thin tissue sections (Diamond *et al.* 2003).

[0006] Empirical methods with similar themes have also been developed. The single fiber method was used in conjunction with an empirically-derived correction factor dependent on the optical properties at the emission wavelength to further compensate for high tissue attenuation in the prostate during PDT studies (Finlay *et al.* 2006). A fluorescence/reflectance ratio has been used to quantify fluorophore concentration, but with the fluorescence and reflectance measured at different source-collector distances (Weersink *et al.* 2001). In all of the above methods, the excitation source operates in the region of low tissue absorption, which invalidates their use in the UV-blue-green end of the spectrum (*i.e.* approximately from 350-575 nm), where a very large subset of fluorophores have fluorescence absorption maxima, such as porphyrins, background autofluorescence and a multitude of artificial fluorescent dyes.

[0007] *Ex vivo* extraction techniques have also been developed that are based on homogenizing the tissue and diluting the analyte to the point that effects due to optical scattering and absorption are negligible (Lilge *et al.* 1997). These procedures are relatively time-consuming and open to error due to tissue handling or cryofreezing for post-processing. It would be useful to provide an *in situ* fluorometric approach that has applicability to a wide variety of fluorophores and tissues.

Summary

[0008] The present disclosure describes a device for quantifying fluorescence and optical properties in a turbid medium, such as tissue. In particular, the device may be in the form of a fiberoptic probe for use in fluorometric applications in tissue. The present disclosure also describes an associated system for controlling optical signals to and from the probe and

algorithms to quantify optical parameters from the probe measurements. The disclosed device may be used as an *in vivo* instrument to quantify fluorescence in tissue. The device and associated systems and methods may compensate for the effects of tissue optical property variation on the perceived fluorescence.

[0009] In some examples, the fiberoptic probe generally has a handle attached to a hypodermic needle-like probe that contacts tissue, which may be flat and includes a linear array of fiberoptics at the tip. Alternatively, the tip may be configured to have an angle or taper such that it may more easily push through tissue, for example for interstitial measurement, similar to a hypodermic needlepoint. A series of excitation light sources are routed through the probe tip via a source fiberoptic and the resulting reflectance and/or fluorescence spectra are measured at a distance through a detector fiber. In this way, measurements of the tissue fluorescence and white light reflectance (reflectance may be taken at varying source-collector fiberoptic distances) can be made. Applying an appropriate model of light interaction with tissue, the quantitative fluorescence, absorption and transport scattering properties (μ_a and μ_s') of the tissue can be determined, as well as other physiological metrics such as tissue oxygenation and hemoglobin concentration.

[0010] In some examples, the device includes: a handheld probe culminating in a narrow tip that contacts the tissue; fiberoptics bundled into the probe tip and probe handle and leading to a control system; the fiberoptics at the tip arranged in a linear array. The device may be used with: a control system that routes optical signals to and from the probe handle; a computer that is connected to the control system. The device may be used with algorithms to compute the optical properties and derive the quantitative fluorescence. The system may provide the software on the computer to handle the algorithm computation, data acquisition and control; and a user interface to control the settings of the data acquisition.

[0011] The disclosed device, system and method may be used to extract the *quantitative fluorescence spectrum* (*i.e.* the fluorescence spectrum corrected for optical properties effects), and consequently fluorophore concentration, using a fiberoptic probe that comes into contact with or is buried interstitially within the tissue. The optical properties, diffuse reflectance spectrum and *measured fluorescence spectrum* (*i.e.* the raw, uncorrected fluorescence

measurement that is distorted by optical properties effects) are inputs to the model. Since the tissue optical properties need to be known, a method to extract these is also described, that may be referred to as spectrally-constrained diffuse reflectance.

[0012] In some aspects, there is provided an optical probe for quantifying fluorescence and optical properties in tissue, the probe comprising: a probe body and a probe tip at a distal end of the probe body, the probe tip being configured to substantially contact a target surface; at least one detector at the probe tip for detecting fluorescence emission or reflectance wavelengths from the target surface; at least one fluorescence excitation source at the probe tip for providing fluorescence excitation light to the target surface, each one of the at least one fluorescence excitation source being at a known distance from each one of the at least one detector; at least two broadband sources at the probe tip for providing broadband wavelengths to the target surface, each one of the at least two broadband sources being at a known distance from each one of the at least one detector; wherein the device is configured to communicate signals from the at least one detector representing the detected wavelengths to a processing device.

[0013] In some aspects, there is provided a method for quantifying optical properties in a turbid medium, the method comprising: providing fluorescence emission and reflectance wavelengths detected from a target surface, each of the detected wavelengths being associated with a respective known distance between a respective excitation source giving rise to the respective detected wavelength and a detector detecting the respective detected wavelength, the known distances being predetermined to enable calculation of a desired range of values for the optical properties; and calculating the optical properties based on the detected wavelengths and the respective known distances, and based on a model of light interaction with the turbid medium, the model limiting a range of calculated values for the optical properties.

[0014] In some aspects, there is provided a method for quantifying fluorescence in a turbid medium, the method comprising: providing fluorescence emission and reflectance wavelengths detected from a target surface, each of the detected wavelengths being associated with a respective known distance between a respective excitation source giving rise to the respective detected wavelength and a detector detecting the respective detected wavelength, the known distances being predetermined to correspond to a desired range of values for the optical

properties; providing quantified optical properties corresponding to the detected wavelengths; and calculating the fluorescence based on the detected wavelengths and the corresponding optical properties, based on known relationships between the detected fluorescence emission wavelengths and the detected reflectance wavelengths arising from the known distances, and based on a model of light interaction with the turbid medium, the model limiting a range of calculated values for the optical properties. In some examples, the method for quantifying fluorescence may also include the method for quantifying optical properties described above.

[0015] In some aspects, there is provided a system for quantifying optical properties in tissue, the system comprising: the probe described above; a plurality of light sources for providing fluorescence excitation and broadband wavelengths to the fluorescence excitation source and broadband sources; a spectrometer for measuring wavelengths detected by the detector; and a controller for controlling fluorescence emission and detection by the sources and the detector; wherein the system is in communication with a processing device configured for calculating at least one optical property based on the measured wavelengths.

Brief Description of the Drawings

[0016] FIG. 1 is a schematic of an example device for quantifying fluorescence and optical properties;

[0017] FIG. 2 is a schematic of another example device for quantifying fluorescence and optical properties;

[0018] FIG. 3 is an end-on view of an example probe tip suitable for the example device of FIG. 1 or FIG. 2;

[0019] FIG. 4 is an end-on view of another example probe tip suitable for the example device of FIG. 1 or FIG. 2;

[0020] FIG. 5 is a schematic of an example system suitable for use with the example device of FIG. 1 or FIG. 2;

[0021] FIG. 6a and FIG. 6b show photographs of an example device and an example system for quantifying fluorescence and optical properties;

[0022] FIG. 7 shows a schematic of example fiberoptic-mediated fluorescence detection;

[0023] FIG. 8 shows a schematic of another example fiberoptic-mediated reflectance detection;

[0024] FIG. 9 is a diagram illustrating an example method for quantifying fluorescence and optical properties;

[0025] FIG. 10 shows a graph of reflectance versus μ_s' for an example fiberoptic distance of 500 μm ;

[0026] FIG. 11 shows a bar graph for three example fiberoptic distances ($r = 260, 520$ and $780 \mu\text{m}$) and their range of validity according to an example model for quantifying optical properties;

[0027] FIG. 12 is a table showing phantom optical properties for an example study of an example system and method for quantifying optical properties;

[0028] FIG. 13 shown example phantom fluorescence spectra (a) uncorrected for optical properties variation and (b) corrected for the effects of the optical properties;

[0029] FIG. 14 shows a) measured fluorescence and b) estimated fluorophore concentration versus true PpIX concentration, from an example study;

[0030] FIG. 15 shows images of example PpIX phantoms A-I;

[0031] FIGS. 16A and 16B displays fluorescence measurements from an example *ex vivo* mouse experiment;

[0032] FIG. 17 is a table showing baseline characteristics for patients in an example study of an example system and method for quantifying optical properties;

[0033] FIG. 18 shows plots of example optical properties spectra and reflectance data from an example study of an example system and method for quantifying optical properties;

[0034] FIG. 19 shows plots of example fluorescence data from a patient with a meningioma, measured using an example device for quantifying fluorescence and optical properties;

[0035] FIG. 20 shows example fluorescence images and corresponding example fluorescence spectra from a patient with a glioma, measured using an example device for quantifying fluorescence and optical properties;

[0036] FIG. 21 is a table showing comparisons of example PpIX concentration levels from an example study of an example system and method for quantifying optical properties;

[0037] FIG. 22 is a table showing example diagnostic variables tested in an example study of an example system and method for quantifying optical properties;

[0038] FIG. 23 shows plots of example *in vivo* quantitative fluorescence from an example study of an example system and method for quantifying optical properties;

[0039] FIG. 24 shows plots of example diagnostic variables tested in an example study of an example system and method for quantifying optical properties; and

[0040] FIGS. 25-29 are tables of example data for diagnostic variables tested in an example study of an example system and method for quantifying optical properties.

Detailed Description

[0041] The present disclosure describes a device, system and method that may be used for recovering the quantitative fluorescence, individual fluorophore concentrations, and/or other optically-determined physiological metrics (*e.g.*, in the case of tissue, the tissue oxygenation, hemoglobin concentration, *etc.* may be recovered). Any measureable tissue fluorescence may be significantly affected by the measurement geometry and tissue optical properties. For example, fluorescence image intensity (in epi-illumination mode) varies with camera-to-tissue distance approximately according to an inverse law. An increased blood volume significantly attenuates fluorescence intensity due to the high absorption of hemoglobin. Attempts to quantify the fluorescence without taking into account these factors may lead to incorrect interpretation.

[0042] The disclosed device, system and method may help reduce, minimize or eliminate the issue of varying measurement geometry by fixing the source and detector geometry (*e.g.*, as mediated with fiberoptics embedded in a cylindrical probe head) and by making contact with the tissue during measurement. As well, measurement of optical properties in combination with a

novel fluorescence model and algorithm may be used to remove the distorting effects of the tissue optical properties.

[0043] The present disclosure describes a combination of the “hardware” equipment (*e.g.*, fiberoptic probe, control system and computing hardware) required to produce the spectroscopic measurements and the “software” algorithms to process the raw data to reconstruct the quantitative fluorescence spectrum, fluorophore concentration(s), optical properties and/or physiological metrics such as tissue oxygenation and hemoglobin concentration in the case of tissue. The software part may be further divided into the optical properties calculation part and the quantitative fluorescence calculation part. The result from the optical properties calculation is used in the quantitative fluorescence part; however, any suitable method of obtaining optical properties may be used in the quantitative fluorescence part. Thus, although the two are discussed together, the quantitative fluorescence calculation may be performed independent of the described optical properties calculation, even though the result of the optical properties calculation is used in the quantitative fluorescence calculation. The following description discusses the hardware and software parts separately; however, both parts may be used together.

[0044] The following is a description of an example of the hardware portion. FIG. 1 illustrates an example of the device, in this case a portable fiberoptic probe. In this example, the handle 9 is connected to the probe barrel 1 on one end and the fiberoptic lead 10 leading back to the control system (not shown) where the optical signals are received. The tip of probe barrel 1 is the part that actually contacts the tissue site of interest. Examples of suitable tip geometries are shown in FIG. 3 and FIG. 4. The fiberoptic lead 10 includes, in this example configuration, four separate optical fibers, which are split apart from the main lead into four separate leads by part 11. The four separate leads terminate into fiberoptic connectors 12, 13, 14 and 15. The fiberoptic lead 10 connects the probe via connectors 12,13,14 and 15 to the control system (see FIG. 5).

[0045] The probe may also be catheterizable, as shown in the example device of FIG. 2. The example shown in FIG. 2 is similar to that of FIG. 1, however in FIG. 2, the probe barrel 1 is connected directly to the fiberoptic lead 10 to enable catheterization. Other such modifications may be made to the device to accommodate its use in various procedures.

[0046] In some examples, the probe tip geometry can take the form shown in FIG. 3. FIG. 3 is an end-on view of an example of the probe tip. The fibers are aligned in a linear array with varying distances from each other. In this example configuration, adjacent fibers are 260 μm apart. Probe barrel 1 has the optical fibers built into it, for example held in place with epoxy 8 or any other suitable fixative, such that their geometry with respect to each other is well-defined and relatively unchangeable. Fibers 2-5 in this case are connected to fiberoptic connectors 12-15 (see FIG. 1). The probe tip may be ground flat and polished in order to maximize signal from the probe tip.

[0047] The probe tip may have more than four fibers, such as that as shown in the example tip of FIG. 4. In this example, six fibers are shown, although more or less fibers may be used. The fibers are located at known distances from each other. One source-collector pair is used to measure the tissue fluorescence spectrum (for example, in the example probe tip of FIG. 4, this may be fiber 2' as the fluorescence excitation source and fiber 3' as the detector). The other fibers are used to measure the diffuse reflectance spectrum at different fiberoptic separation distances (for example, in FIG. 4, the detector fiber 3' measures the diffuse reflectance spectrum at different distances as white light is sequentially sent through fibers 4', 5', 6' and 7'). Although in the examples shown, the source and detection fibers are arranged in a linear manner, other fiber configurations may be possible. For example, the fibers may be arranged in a circular, staggered or random configuration, as long as their relative distances r are defined. In the example method and model described below, it may be useful to have at least one white light source fiber at the same distance from the detector fiber as at least one fluorescence excitation source fiber. There may be more than one fluorescence excitation source fiber provided, with possibly different fluorescence excitation wavelengths for different fluorescence excitation source fibers. In some examples, it may be useful to have all fluorescence excitation source fibers the same distance away from the detector. The use of different excitation wavelengths may allow for excitation of a variety of fluorophores. For example, one way to implement multiple fluorescence excitation source fibers into the example shown in FIG. 3 may be to add fluorescence excitation source fibers 260 μm above and beneath the detector fiber 3.

[0048] The use of multiple fiberoptic distances for measuring the diffuse reflectance is related to techniques in measuring the tissue optical properties (recall that the tissue optical properties need

to be estimated to feed into the quantitative fluorescence algorithm). Spectrally-constrained diffuse reflectance methods have been developed that allow the use of a single fiberoptic source-collector pair (for example, see FIG. 8). The source fiber delivers broadband or white light and the diffuse reflectance spectrum is detected by the collector fiber located at a distance, r . Since there is only one reflectance measurement per wavelength, λ , solving for μ_a and μ_s' relies upon spectral constraints, *i.e.* applying *a priori* knowledge of the shapes of $\mu_a(\lambda)$ and $\mu_s'(\lambda)$ in a forward model, which can then be used to solve for the absolute coefficient values. A challenge with the spectrally-constrained diffuse reflectance method is the relatively limited dynamic range of μ_a and μ_s' that can be measured with a single source-collector distance. Therefore, one of the purposes of using multiple source-collector distances for measuring the diffuse reflectance is to span a large dynamic range of optical properties. Since each distance spans a unique range over which μ_a and μ_s' can be measured, overlap of the reflectance measurements at multiple distances may help to extend the dynamic range beyond that of each distance separately.

[0049] The way that reflectance behaves with increasing reduced scattering coefficient, μ_s' , is to increase with increasing μ_s' , peak, and then decrease. An example of this is shown in FIG. 10, which is an example graph of reflectance versus μ_s' for a fiberoptic distance of 500 μm . The peak is indicated as a cut-off point for the “usefulness” of the reflectance for estimating the optical properties, since only the part which is monotonically increasing or the part that is monotonically decreasing can be used, but not both. It has been found that the monotonically increasing part is more sensitive to changes in μ_s' , so this part is used for optical properties measurement in the examples described. However, it should be understood that the monotonically decreasing part may also be used. The reflectance peak of FIG. 10 is at relatively high μ_s' for small fiberoptic distance, r ; hence, close fiberoptic distances (in this example, $r < 2$ mm) are used to span a large dynamic range of μ_s' .

[0050] In the disclosed device, there are multiple optical fibers for measuring the diffuse reflectance in order to span a large range of tissue optical properties. Since a diffusion theory model is used for optical properties extraction (described below), there is a lower bound of validity of μ_s' for a given r such that diffusion theory is valid. As well, if the monotonically increasing part (with respect to μ_s') is being used then the reflectance peak (see FIG. 10) represents an upper bound for a given r . Therefore, different r distances have different dynamic

ranges for optical properties measurement. For example, in the case of $r = 260, 520$ and $780 \mu\text{m}$, these dynamic ranges are shown in FIG. 11. FIG. 11 shows a bar graph for three fiberoptic distances ($r = 260, 520$ and $780 \mu\text{m}$) and their range of validity according to the reduced scattering coefficient, μ_s' . The lower bound is due to the diffusion theory model breaking down at low μ_s' ; the upper bound is due to the reflectance peak. This figure shows the need for multiple fiberoptic distances, r , to span a large overall dynamic range of optical properties. The technique of spectrally constrained diffuse reflectance using multiple r to expand the dynamic range of optical properties measurement may differ from conventional methods.

[0051] An alternative purpose to having multiple source-collector distances for measuring tissue optical properties is to use a technique called spatially-resolved diffuse reflectance. Essentially, the reflectance measurements at multiple r can constrain the solution such that μ_a and μ_s' can be solved for in a non-linear least squares solution. This solution may have some drawbacks, including, for example: relatively slower acquisition times and larger r values, which may necessitate bulkier probe head diameters; and a less robust solution that may lead to spurious results in a dynamically changing biological environment (*e.g.* breathing and pulsatile blood flow). Spatially-resolved diffuse reflectance is, however, still a viable technique for extracting tissue optical properties for the purpose of inputting into the quantitative fluorescence algorithm.

[0052] In operation, the probe sequentially sends fluorescence excitation light and broadband light (for each r distance) into the tissue to obtain the fluorescence and diffuse reflectance spectra, respectively. The fluorescence spectrum depends on five main parameters, the absorption and transport scattering coefficients at the excitation wavelength, $\mu_{a,x}$ and $\mu_{s,x}'$, and the emission wavelength, $\mu_{a,m}$ and $\mu_{s,m}'$, and fluorophore content. In this disclosure, the x and m suffices are used to denote excitation and emission, respectively. The reflectance spectrum depends on the wavelength-dependent absorption and scattering coefficients, $\mu_a(\lambda)$ and $\mu_s'(\lambda)$. Based on a diffusion theory model of light transport in tissue, all of these quantities can be calculated from the fluorescence and reflectance measurements. As well as fluorescence quantification being achieved, many other useful parameters can be calculated from the data, such as tissue oxygenation, hemoglobin concentration and a metric of the abundance of optical scatterers in tissue such as cells, organelles and the extracellular matrix.

[0053] FIG. 5 shows a schematic of an example system suitable for use with the device described above. This example control system may be used to control optical signals flowing into and out of the example probe. A data output card 24 communicates with and is controlled by a processing device, such as an external computer (not shown). The system also includes a spectrometer 19 that communicates with the processing device. The data output card 24 controls multiple light-emitting-diodes (LEDs) 16, 17 and 18 that provide the excitation light for the fluorescence and white light reflectance spectral measurements. The data output card 24 communicates to a processing device (e.g., an example control computer) for data acquisition and control via a data output port 22. Fiberoptic connector ports 25, 26, 27 and 28 are used to connect the fiberoptic probe to the control system. The detector fiber (for example, in FIG. 3 and FIG. 4 the fiber in the probe tip is 3 and 3', respectively) is plugged into the spectrometer 19. Alternatively, a detector with an appropriate emission filter may be used for single-wavelength detection. Another possibility for detection would be a charge-coupled device (CCD) in combination with a diffraction grating or prism. In all detection configurations, there may be the option to insert a longpass filter in front of the detector to reject the fluorescence excitation. The fluorescence excitation fiber (for example, in FIG. 3 and FIG. 4 this is fiber 2 and 2') is connected to a narrow wavelength band light source, such as an LED 16 as shown (in some examples, a laser or filtered white light source may also be used), through port 25. Additional light sources 17, 18 (for example, LEDs, halogen lamps or other lamps) for the diffuse reflectance measurements send light sequentially through ports 26 and 27. A power supply 20 supplies appropriate voltage and current to all devices (e.g., LEDs and any other electronics) as necessary. An enclosure 23 contains all electrical devices in such a manner that external devices (e.g., the fiberoptic probe and the computer) may be connected to it easily, and that the enclosure is made electrically safe. The enclosure 23 may provide a port for the external electrical supply 21 and a data port 22 (e.g., to connect to a computer).

[0054] Although the example system has been described with certain components, variations may be possible. The system may have more LEDs than those shown. The system may be portable (e.g., the system may include a portable power source such as a battery, and may include an embedded microprocessor rather than communicating with an external processing device). Rather than a data output card in communication with an external computer, the system may include a processor for performing the functions of these components, for example as

described above. In some embodiments, the system may communicate wirelessly with an external processing device rather than through data ports. The system may be adapted or configured to carry out a method for quantifying optical properties, for example by carrying out calculations based on the model described below. In other examples, the system may communicate with an external processing device to carry out such calculations.

Example Device and System

[0055] An example of the above-described device and system is described below. The example is based on the examples shown in FIG. 1, FIG. 3 and FIG. 5. The example may be suitable for pre-clinical and/or clinical evaluation of quantitative fluorescence, for example for delineation of brain tumors during resection surgery. A photograph of the example fiberoptic probe is shown next to a 28 mm diameter Canadian two-dollar coin (for scale) in FIG. 6a. In the example shown, the probe includes a fiberoptic lead, in this case a 3 m long fiberoptic lead. In this example, a linear array of four optical fibers (ThorLabs, Newton, NJ, USA), spaced apart every 260 μm , were epoxied into an 18 Ga hypodermic needle tube. The silica core of the fiber was 200 μm , with a numerical aperture of 0.22. The hypodermic needle part was affixed to a stainless steel handle, with the four fibers extending 3 m to SMA 905 fiberoptic connectors.

[0056] The example system is shown in FIG. 6b. In this example, the system includes the probe, and a control system, in communication with an external processing device, in this case a data acquisition computer. The system may also include an isolation transformer, as shown, for additional electrical isolation, which may be useful when the system is to be used in the operating theatre. The control system directs the flow of optical signals into and out of the probe handle. The white light sources for the diffuse reflectance measurements and the source for fluorescence excitation (in this example, at around 405 nm) in this example are LEDs (LEDengin, Santa Clara, CA, USA), controlled by computer via a data output card (Measurement Computing, Norton, MA, USA). The fluorescence LED was filtered with a 550 nm shortpass filter (Edmund Optics, Barrington, NJ, USA). The spectrometer was a USB2000+ model (Ocean Optics, Dunedin, FL, USA). In other examples, the fluorescence excitation wavelength may be in the range of about 350 nm to about 600 nm, for example 500 nm to about 600 nm or 380 nm to about 420 nm, although other ranges may also be used, including

wavelengths greater than 600 nm and wavelengths less than 350 nm. The fluorescence excitation wavelength may be selected based on known characteristics of the excitation target, which may be, for example, a tissue target or a fluorophore. For example, when the excitation target is a tissue having a significant hemoglobin content, the excitation wavelength may be selected to be no greater than about 600 nm since hemoglobin has greater absorption at wavelengths less than 600 nm; for other excitation tissue or non-tissue targets which absorb wavelengths in different ranges, other excitation wavelength ranges may be used.

[0057] A data acquisition computer (e.g., a desktop computer or a laptop computer) may be used to control the LED signals and spectrometer acquisition. The computer may include software for carrying out data acquisition using the system. In other examples, the system may itself be configured to execute such software, without communicating with an external processing device. In this example, the program acquired the following sequence of measurements:

1. White light reflectance spectrum @ $r = 260 \mu\text{m}$
2. White light reflectance spectrum @ $r = 520 \mu\text{m}$
3. Fluorescence spectrum (405 nm excitation) @ $r = 260 \mu\text{m}$
4. Background signal (no light through probe)

[0058] In this example, a measurement sequence takes ~ 0.5 seconds. These measurements may be used in a model for quantifying optical properties, as discussed below. In this example, the white light reflectance and fluorescence spectra obtained at $r = 260 \mu\text{m}$ were used for the quantitative fluorescence and spectral fitting calculations (e.g., Eqs. (5) and (7) described below). The white light reflectance spectrum obtained at $r = 260$ and $520 \mu\text{m}$ was used for the extraction of optical properties using the spectrally-constrained diffuse reflectance method (e.g., Eqs. (9)-(11) described below).

[0059] In this example, the reflectance measurements were calibrated according to phantoms of known optical properties such that the reflectance is in absolute units of cm^{-2} . The fluorescence measurements were calibrated according to a Intralipid (Fresenius Kabi: Uppsala, Sweden) and added absorber liquid phantom with known $\mu_{a,x}$, $\mu_{s,x}'$ and fluorophore concentration.

[0060] In some examples, a phantom (e.g., a solid, sterilizable phantom) may be used as a pre-surgical calibration tool for an example of the disclosed probe. For example, the phantom may fluoresce in the spectral range of interest, and may also provide background optical scattering and/or absorption for reflectance calibration. The optical properties of the phantom may be measured using the probe (e.g., using simple light contact with the surface of the phantom) after absolute calibration, such as using the liquid phantom as described above. The solid phantom may provide a relative standard for fluorescence and reflectance. Since solid phantoms may be relatively stable, long-lasting and sterilizable (e.g., including quantum dots as fluorescent particles and/or titanium dioxide particles for background scattering), solid phantoms may be suitable for calibration immediately prior to surgery, which may not be possible for liquid phantoms. Determination of the quantitative relationship between probe signals measured from the solid phantom and the liquid phantom may allow the fluorescence and/or reflectance measurements of the probe to be calibrated ahead of a surgical procedure.

Example Model

[0061] An example model for modeling of fluorescence and reflectance detection as mediated by the fiberoptic geometry described above is now discussed. Although certain equations and theories are described below, the present disclosure is not intended to be limited to these specific theories or assumptions.

[0062] Much of the research concerning the extraction of fluorophore concentration involves excitation wavelength(s) where the tissue attenuation is low. The challenge here is to decouple the quantitative fluorescence from the optical properties of tissue given high optical attenuation at the excitation (relative to the emission band), since many fluorophores have their absorption peaks in the ultraviolet-to-green spectral region, where tissue absorption is high. This example model may provide a simple, closed-form, analytical model to extract the quantitative fluorescence spectrum with excitation wavelengths in regions of high absorption relative to the emission band. In order to extract the quantitative fluorescence, the tissue optical properties must be known at the excitation wavelength, which can be estimated using the spectrally-constrained diffuse reflectance technique. Fluorophore concentrations can then be extracted from the quantitative fluorescence spectrum through spectral decomposition using *a priori* fluorescence

emission basis spectra. The basis spectra are essentially the shapes of the component fluorescence spectra. The fluorescence model may be implemented in the device and system described above. The example model may be useful for investigations into aminolevulinic acid (ALA)-induced protoporphyrin IX (PpIX) tumor contrast for guided resection surgery of brain tumors, for example; hence, PpIX is used as the target fluorophore in this example.

[0063] FIG. 7 shows a schematic of example fiberoptic-mediated fluorescence detection. Excitation light (usually a narrow wavelength band, *e.g.*, <50 nm wide) enters the tissue through the source fiber and undergoes transport scattering and optical absorption according to the excitation optical properties, $\mu_{s,x}$ and $\mu_{a,x}$. If and when excitation photons are absorbed by fluorophores in the tissue (in this example, it is understood or assumed to be uniformly distributed throughout the tissue at a concentration $[c]$) some of the photons are re-emitted as fluorescence photons according to the fluorophore's quantum yield. The emission photons are isotropically radiated and are transported through the tissue according to the emission optical properties, $\mu_{s,m}$ and $\mu_{a,m}$. Fluorescence emission is collected by an optical fiber at a distance r away.

[0064] The following fluorescence model is based on (but not limited to) the assumption that the optical absorption at the excitation wavelength, λ_x , is high relative to that at the emission wavelength, λ_m . This is generally true in tissue if the excitation wavelength is in the UV-blue-green end of the visible spectrum (~350-575 nm) and the emission wavelength is >600 nm. As a result, the fluence rate distribution at the excitation wavelength is extremely close to the fiberoptic source; therefore, most fluorophore absorption events occur close to the source fiber. The migration paths of the fluorescence photons at λ_m can then be approximated as the migration paths of the reflectance photons at λ_m emitted and collected using the same fiberoptic geometry. It follows from this that the measured fluorescence, $F_{x,m}$, has a linear relationship with the diffuse reflectance at the emission wavelength, R_m , with both fluorescence and reflectance measured using the same geometry:

$$F_{x,m} = S R_m \quad (1)$$

, where the term, S , denotes the fraction of photons that are re-emitted as fluorescing photons from the total number of excitation photons launched into the tissue.

[0065] The term S can be modeled as the fraction of the total excitation photons that are retained within the tissue at steady-state, S_1 , multiplied by the fraction of the total absorbed photons that are re-emitted as fluorescence photons, S_2 . At steady-state, the number of excitation photons retained within the tissue is equal to the photons that are not diffusely reflected out of the tissue. The fraction of excitation photons that are diffusely reflected is the total diffuse reflectance, $R_{t,x}$, which depends on the internal reflection parameter, $\kappa = (1 + r_{id}) / (1 - r_{id})$ (due to index mismatch between tissue and the external medium), and the reduced albedo at λ_x , $a_x' = \mu_{s,x}' / (\mu_{a,x} + \mu_{s,x}')$, which is given by diffusion theory (Flock *et al.*, 1989):

$$R_{t,x} = \frac{a_x'}{1 + 2\kappa(1 - a_x') + \left(1 + \frac{2\kappa}{3}\right)\sqrt{3(1 - a_x')}}. \quad (2)$$

[0066] An empirical formulation of r_{id} for index-mismatched boundaries has widely been used, where $r_{id} = -1.44n_{rel}^{-2} + 0.71n_{rel}^{-1} + 0.67 + 0.0636n_{rel}$, and $n_{rel} = n_{tissue}/n_{external}$ (Groenhuis *et al.* 1983). For matching internal and external refractive indices, $\kappa = 1$. In this example, matched indices were assumed. The blackened (with ink) epoxy surrounding the fibers in the probe acts as the external medium, and the ink-epoxy is assumed to be approximately index-matched to tissue. S_1 is the fraction of photons that are not diffusely reflected out of the tissue, so $S_1 = (1 - R_{t,x})$.

[0067] The quantitative fluorescence, $f_{x,m}$, is defined here as the product of the wavelength-dependent fluorescence quantum yield, $Q_{x,m}$, and the fluorescence absorption coefficient at the excitation wavelength, $\mu_{af,x}$, and is therefore an intrinsic property of the tissue, rather than a function of the collection geometry. The fraction of total absorbed photons that undergo fluorescence conversion, S_2 , is simply the quantitative fluorescence divided by the total absorption:

$$S_2 = \frac{Q_{x,m} \mu_{af,x}}{\mu_{a,x}}. \quad (3)$$

[0068] The measured (uncorrected) fluorescence can now be expressed as:

$$F_{x,m} = (1 - R_{t,x}) \left(\frac{Q_{x,m} \mu_{af,x}}{\mu_{a,x}} \right) R_m \quad (4)$$

[0069] If the fluorophore absorption contribution is negligible compared to the tissue absorption, *i.e.* $\mu_{af,x} \ll \mu_{a,x}$, then $\mu_{a,x}$ can be approximated to be the same as the background tissue absorption alone. A closed form equation for the quantitative fluorescence is:

$$f_{x,m} = Q_{x,m} \mu_{af,x} = \left(\frac{\mu_{a,x}}{1 - R_{t,x}} \right) \left(\frac{F_{x,m}}{R_m} \right) \quad (5)$$

[0070] Clearly, if $\mu_{a,x}$ goes to zero, the corrected, quantitative fluorescence, $f_{x,m}$, should not go to zero. Recall the underlying assumption that $\mu_{a,x}$ is high—Eq. (5) would be invalid at low excitation absorption. This negates the possible scenario of $\mu_{a,x} = 0$. Note that the quantitative fluorescence spectrum has absolute units of $\text{nm}^{-1} \cdot \text{cm}^{-1}$.

[0071] Modifications to this fluorescence model are possible. For example, the above model may be modified in order to accommodate proper operation for interstitial measurements in addition to tissue surface measurements. This may be accomplished, for example, by forming a model of the total diffuse reflectance using an interstitial geometry. In another example, the model may be modified to accommodate an angled or tapered tip geometry, such as where an angled tip is used in the probe to help improve the ability of the probe to push through tissue for interstitial measurements. As well, the S_1 factor may be computed using another means other than diffusion theory, such as the Monte Carlo technique. In addition, if the fluorescence and reflectance do not perfectly scale linearly with each other (as in Eq. (1)), a correction factor S_3 may be included to compensate for cases where the assumption that the fluorescence photon migration paths are similar to the reflectance photon migration paths does not hold. S_3 may be derived via diffusion theory, Monte Carlo or empirical techniques.

[0072] Eq. (5) yields an emission spectrum, $f(\lambda_m)$, that can be used to quantify fluorophore concentration, c , given an *a priori* fluorescence basis spectrum, $b(\lambda)$, equivalent to one concentration unit [$\mu\text{g/mL}$]. The relation is:

$$\mathbf{f} = \mathbf{b} \mathbf{c} \quad (6)$$

, where \mathbf{f} and \mathbf{b} are $f(\lambda)$ and $b(\lambda)$ in column vector form. Taking the pseudo-inverse gives \mathbf{c} :

$$\mathbf{c} = (\mathbf{b}^T \mathbf{b})^{-1} \mathbf{b}^T \mathbf{f} \quad (7)$$

[0073] Generalizing to N fluorophores with distinct spectra, a basis matrix, $\mathbf{B} = [\mathbf{b}_1 \mathbf{b}_2 \dots \mathbf{b}_N]$, can be built with the individual fluorophore basis spectra as its columns, with a corresponding fluorophore concentration vector, $\mathbf{c} = [c_1 c_2 \dots c_N]^T$. Solving for \mathbf{c} :

$$\mathbf{c} = (\mathbf{B}^T \mathbf{B})^{-1} \mathbf{B}^T \mathbf{f} \quad (8)$$

[0074] Some assumptions in this example fluorescence model include:

[0075] 1. Reflectance photons and fluorescence photons traverse similar path lengths given the same fiberoptic distance, given that $\mu_{a,x} \gg \mu_{a,m}$, which is generally true if the excitation wavelength is in the high absorption band of hemoglobin (UV-blue-green) and the emission wavelength is in the red-to-near infrared (NIR).

[0076] 2. $\mu_{a,x} \gg \mu_{af,x}$. In many cases, the fluorophore contribution to $\mu_{a,x}$ may be small compared to the high absorption of hemoglobin in the range of about 350-600 nm, but this should be considered based on the expected maximum concentration of the fluorophore of interest.

[0077] The fluorescence model of Eq. (5) requires the excitation tissue optical properties, $\mu_{a,x}$ and $\mu_{s,x}'$. A method that we have established to measure the optical properties employs a fiberoptic source-collector pair to measure the steady-state diffuse reflectance spectrum, as shown in FIG. 8. The following describes this technique, which may be referred to as spectrally-constrained diffuse reflectance.

[0078] FIG. 8 shows a schematic of example fiberoptic-mediated reflectance detection. A broad-band excitation is directed into the tissue via a source optical fiber. The broad-band excitation is generally a white light with potentially some content in the near infrared to infrared spectral region, for example in the order of 450-850 nm wide. The light undergoes transport scattering and absorption through the tissue that is wavelength dependent. Here, the optical properties are

denoted as $\mu_{s,m}'$ and $\mu_{a,m}$, where the emission wavelength m represents any one wavelength in the excitation broad-band. The wavelength-dependent reflectance spectrum is measured by a collector optical fiber at a distance r from the source fiber. Although there may be fluorescence events here, they are considered to be negligible compared with the signal strength from the reflectance photons.

[0079] The source fiber delivers broadband white light in the spectral range of interest and the diffuse reflectance spectrum is detected by the collector fiber located at a radial distance, r , from the source, and measured using a spectrometer. Since there is only one reflectance measurement per wavelength, solving for $\mu_a(\lambda)$ and $\mu_s'(\lambda)$ relies upon spectral constraint, that is, using *a priori* knowledge of the shapes of the absorption and scattering coefficient spectra in the forward model. The concept here is to determine $\mu_a(\lambda)$ and $\mu_s'(\lambda)$ over a spectral range (e.g., 450-850 nm) to provide a good model fit, then extract $\mu_a(\lambda_x)$ and $\mu_s'(\lambda_x)$ by extrapolating to the excitation wavelength, which in this example $\lambda_x = 405$ nm. Using this approach to find the tissue optical properties requires caution that the absorption contributions of the fluorophores do not significantly distort the reflectance signal, and thereby the model-based curve-fitting described below.

[0080] The absorption spectrum can be modeled as a linear combination of the separate chromophore contributions. Here, it is expressed using total hemoglobin concentration [g/L] and an oxygen saturation term:

$$\mu_a(\lambda) = c_{Hb} \left[StO_2 \mu_a^{oxyHb}(\lambda) + (1 - StO_2) \mu_a^{deoxyHb}(\lambda) \right] \quad (9)$$

, where $\mu_a^{oxyHb}(\lambda)$ and $\mu_a^{deoxyHb}(\lambda)$ are the wavelength-dependent absorption coefficients of oxygenated hemoglobin, and deoxygenated hemoglobin, respectively, for a concentration of 1 g/L. c_{Hb} is the total hemoglobin concentration and StO_2 is the oxygenation fraction. Here, water is considered negligible in the range 450-850 nm.

[0081] The reduced scattering coefficient spectrum from bulk tissue has been shown to fit well to a simple wavelength-dependent power law, given by

$$\mu_s'(\lambda) = A\lambda^{-b} \quad (10)$$

where A and b are constants.

[0082] The *a priori* knowledge of the chromophore and scatterer spectra are then combined in a forward model of the diffuse reflectance and a Levenberg-Marquardt algorithm is then applied to extract the free parameters. A simple approach to develop a forward model is to use the diffusion theory equation for spatially-resolved, steady-state diffuse reflectance, R . Here, the radial distance, r , is fixed and the optical properties $\mu_a(\lambda)$ and $\mu_s'(\lambda)$ vary according to wavelength:

$$R(\lambda) = \frac{\alpha'}{4\pi} \left[z_0 \left(\mu_{eff} + \frac{1}{\rho_1} \right) \frac{e^{-\mu_{eff}\rho_1}}{\rho_1^2} + (z_0 + 2z_b) \left(\mu_{eff} + \frac{1}{\rho_2} \right) \frac{e^{-\mu_{eff}\rho_2}}{\rho_2^2} \right] \quad (11)$$

, where $z_0 = 1/\mu_s'$, $\mu_{eff}(\lambda) = \sqrt{3\mu_a(\lambda)\mu_s'(\lambda)}$, $\mu_a(\lambda)$ and $\mu_s'(\lambda)$ are given by Eqs. (9) and (10), $\rho_1^2 = z_0^2 + r^2$ and $\rho_2^2 = (z_0 + 2z_b)^2 + r^2$. The parameters z_0 , r_1 , r_2 , z_b and μ_{eff} are all wavelength-dependent. The z_b factor depends on μ_a , μ_s' and the internal reflection parameter κ . The extrapolated boundary distance is given by $z_b = 2\kappa D$, where D is the diffusion constant given by $D = (3\mu_s')^{-1}$. This version of the diffusion constant was selected for reasons given in previous studies on the measurement of tissue optical properties. For matching internal and external refractive indices, $\kappa = 1$, which was assumed in this example, although this is not a requirement in general.

[0083] The free parameters are, therefore, the total hemoglobin concentration, oxygen saturation and scattering parameters. This is not quite as simple as applying the inverse algorithm to any r ; for each r , there is a range of validity that is constrained by the peak of the reflectance versus μ_s' curve, and the diffusion model breakdown at low μ_s' . By using reflectances measured at several r , the ranges of validity overlap, thus increasing the total dynamic range. In this example, $r = 260$ and $520 \mu\text{m}$ were selected. It has been found that for these values of r , the validity range for the spectral constraint technique was $\mu_s' = 10.1\text{-}47.4 \text{ cm}^{-1}$. FIG. 11 shows the lower and upper bounds of μ_s' (for $\mu_a < 10 \text{ cm}^{-1}$) where each fiberoptic distance is valid (e.g., for $r = 260, 520$ and $780 \mu\text{m}$, the $780 \mu\text{m}$ distance shown to demonstrate how a longer distance does expand the overall dynamic range).

[0084] The $r = 260$ and $520 \mu\text{m}$ source-collector distances were used because in this example the brain is the target site of interest and the brain optical properties have been measured as within this range of validity in previous laboratory experiments on murine tissues.

[0085] Variations to the described reflectance model may be possible. For example, as in the case with the fluorescence model, the above reflectance model may be modified in order to accommodate proper operation for interstitial measurements in addition to tissue surface measurements. This may be accomplished, for example, by forming a model of the diffuse reflectance using an interstitial geometry. In another example, the model may be modified to accommodate the geometry of an angled or tapered probe tip, for example where the probe has an angled tip to help the probe to push through tissue in order to take interstitial measurements. Further, as with the quantitative fluorescence model, the light-tissue interaction may be modeled with diffusion theory, Monte Carlo techniques or empirical techniques.

[0086] A technique that was found to relatively accurately determine the optical properties is to calculate $\mu_a(\lambda)$ and $\mu_s'(\lambda)$ for each fiberoptic distance (in this example, this is $r=260$ and $520 \mu\text{m}$) and to determine which r distance to use for the calculation by checking if the $\mu_s'(\lambda)$ value falls within the upper and lower bounds of validity (for example, as shown in FIG. 11).

Example Studies

Phantom studies

[0087] Phantom experiments were carried out to validate the example fluorescence model described above. Intralipid fluid (Fresenius Kabi, Uppsala, Sweden) was used to provide background scattering. Yellow food coloring (McCormick Canada, London, ON, Canada) was used to vary the absorption coefficients. Protoporphyrin IX extract (Sigma-Aldrich) was used as the target fluorophore. A set of nine phantoms were mixed, giving the optical properties shown in FIG. 12.

[0088] PpIX was mixed in six concentrations (5, 2.5, 1.25, 0.625, 0.3125, 0.15625 $\mu\text{g/mL}$) for each set of nine phantoms, for a total of 54 phantoms. Probe measurements were taken in each of the 54 phantoms, and Eq. (5) applied to the data to extract the quantitative fluorescence spectra and the PpIX concentration. As well, images of the liquid phantom surfaces in blackened

cuvettes were taken using a fluorescence stereomicroscope (MZ FLIII: Leica, Wetzlar, Germany) to determine the fluorescence image intensity variation at $[PpIX]=5 \mu\text{g/mL}$.

[0089] This set of experiments was used to validate the example fluorescence model in Eq. (5) and (7), with *a priori* knowledge of the excitation optical properties. The measured fluorescence spectra, $F_{x,m}(\lambda_m)$ for the set of nine phantoms A-I, all with a PpIX concentration of $5 \mu\text{g/mL}$, is shown in FIG. 13a. The raw measurements of FIG. 13a have not been corrected for optical properties variations. Applying Eq. (5) to the data produces the quantitative fluorescence spectra, $f(\lambda_m)$, shown in FIG. 13b, with correction for the effects of optical properties. The relative standard deviation (normalized to the mean) at the 635 nm peak is 53.1% for the measured fluorescence and 10.1% for the quantitative fluorescence estimate.

[0090] The quantitative fluorescence model was applied to the entire data set of 54 phantoms, with the results plotted against PpIX concentration. FIG. 14a shows the measured, raw fluorescence intensities at 635 nm, compared to the estimated $[PpIX]$ concentration shown in FIG. 14b, calculated from the raw data using Eqs. (5) and (7). The dashed line in a) represents the best straight line fit through the origin to the data; the dashed line in b) is the unity line. R^2 calculations were performed on the linear form of the data plot, not the log-log relation. The measured probe signal $F_{x,m}(\lambda_m = 635 \text{ nm})$ was curve-fitted to a linear model with $[PpIX]$ on the x -axis in FIG. 14a. The $[PpIX]$ probe estimate was compared to the known $[PpIX]$ in FIG. 14b. The root-mean-square (RMS) variation from the mean, and maximum deviation from the mean were calculated from the data at $5 \mu\text{g/mL}$ (FIG. 13). The RMS error and maximum error were normalized by the mean. Using the quantitative fluorescence model and spectral fitting, the estimated $[PpIX]$ concentration has an RMS deviation of 10.1% and a maximum deviation of 14.2%, representing a significant decrease in error from the uncorrected fluorescence measurement (RMS deviation 52.3% and maximum deviation 94.9%).

[0091] Fluorescence microscope images of the phantoms were taken in order to get a visual conception of the fluorescence intensity variation due to changes in optical properties. Phantom surface images are shown in FIG. 15 for $[PpIX] = 5 \mu\text{g/mL}$, the intensity differences between phantoms may be easily distinguishable by eye. The most significant intensity difference in this

set of images is between phantom C (highest $\mu_{s,x}'$, lowest $\mu_{a,x}$) and G (lowest $\mu_{s,x}'$, highest $\mu_{a,x}$), where the fluorescence intensity of C is 4.0 times that of G.

Mouse model

[0092] In another example study, a mouse tumor model was used to validate the example probe's accuracy in measuring photosensitizer concentrations in various tissue types, with PpIX as the target marker. The probe estimate of [PpIX] was compared with measurements of diluted, solubilized tissue in a cuvette-based fluorometer, based on a published protocol (Lilge *et al.*, 1997)

[0093] *Tumor induction*: Five male mice (20 grams) were anesthetized with 2% isoflurane and placed on a warming blanket. The skin at the injection site was swabbed with 70% ethanol, and 10^6 B16 melanoma cells in 20 μ L of phosphate buffered saline were injected subcutaneously into the left flank. Tumors were allowed to grow 4-6 mm over 7 days.

[0094] *PpIX measurement in various organ tissues*: After tumors had grown to size, each mouse was injected via tail vein with 100 mg/kg ALA at 0.5, 1, 2, 3 and 4 hours prior to sacrifice. The different time points were selected to ensure a large range of [PpIX] in each tissue. The mice were sacrificed by cervical dislocation while under isoflurane anesthesia. The tissue types of interest (brain, heart, kidney, liver, muscle, skin and tumor) were rapidly excised under subdued lighting conditions and three probe measurements taken per tissue sample. The samples were weighed, placed into cryotubes and then snap frozen in liquid nitrogen. The samples were stored at -70°C in a light-tight container until ready for the tissue solubilisation procedure.

[0095] *Tissue solubilisation protocol*: A tissue solubilisation protocol was used to measure the absolute fluorophore concentration (Lilge *et al.*, 1997). Each tissue sample was combined with 2 mL of Solvable and placed in an undulating water bath at 50°C for 1 hour. The tissue/Solvable solution was homogenized with a Tissue Tearor tool (Biospec Products, Bartlesville, OK, USA) in the original vial. 200 μ L of the tissue homogenate was combined with 3 mL of distilled water and 1 mL of Solvable. This solution was incubated in the water bath at 50°C for 1 h. The optical density was measured and diluted down to <0.1 if necessary. The resulting solution was transferred to a quartz cuvette. The cuvette was analysed via fluorometer (Fluorolog: Jobin

Yvon, Edison, NJ, USA), using an excitation wavelength of 401 nm. A look-up curve was constructed by measuring known concentrations of PpIX in 75/25 distilled water/Solvable solution, with the detector nonlinearity taken into account for the [PpIX] calculations.

[0096] FIG. 16a shows the measured (i.e., uncorrected) fluorescence signal exemplified by the PpIX peak at 635 nm plotted against the [PpIX] measurement from the tissue solubilisation technique for 34 tissue samples. The y-axis has been re-scaled mid-figure to better visualize the higher-value data. The data show significant scatter, with little correlation between the x- and y-axes. Applying the example correction algorithms described above to the data, the resulting [PpIX] estimate from the fiberoptic probe has improved correlation with the [PpIX] measurement from the tissue solubilisation technique (FIG. 16b), demonstrating that the example fiberoptic probe an associated model and method described above may be useful for quantifying fluorophore content in tissue. In FIG. 16a and FIG. 16b, y-axis error bars are standard deviation bars from three measurements on each tissue sample; x-axis error bars were calculated from the root-mean-square (RMS) error percentage from accuracy statistics of the solubilisation protocol (Lilge *et al.*, 1997), multiplied by 0.5 of the maximum [PpIX] measured via tissue solubilisation in this mouse tissue experiment.

Example patient study

[0097] Another example study is now described. In this example study, 14 patients with a variety of intracranial pathologies (including low- and high-grade gliomas, meningioma, and intracranial lung metastases, as indicated in FIG. 17) were administered 20-mg/kg of ALA 3 hours prior to induction of anesthesia. The neurosurgeon performed a conventional standard craniotomy procedure with image-guidance using a surgical microscope modified for PpIX fluorescence. At the surgical bed, the surgeon acquired multiple sets of measurements using an example probe, with corresponding tissue specimens collected and processed for histopathological analysis. In each case, the surgeon acquired probe measurements of normal brain tissue as controls. In addition, the surgeon scored the visible fluorescence as viewed through the fluorescence-capable surgical microscope (scores from 0-4). All specimens were assessed as either normal or abnormal, such that presence of tumor cells was assessed as abnormal. The total numbers of control and biopsy sites are listed in FIG. 17.

[0098] Statistical significance tests, linear discriminant analysis and receiver-operator characteristic analysis were performed on this *in vivo* data set acquired by the example quantitative fluorescence probe.

[0099] *Statistical significance tests*: Since the data in this example were expected to be non-parametric, a Wilcoxon rank-sum test was selected in order to determine how statistically-significant were the several optical parameters derived from the *in vivo* probe data at distinguishing between normal and tumor tissues. PpIX concentration was one of the parameters to be tested. In addition, the following optical parameters were tested for statistical significance in differentiating normal from tumor tissue: the autofluorescence (AF) at 600, 635, 650 and 700 nm, diffuse reflectance (for both $r = 260$ and 520 μm fiber distance) at 575 and 600 nm, oxygen saturation (StO_2), total hemoglobin concentration, f_{Hb} , and μ_a and μ_s' at 575 and 600 nm.

[0100] *Linear discriminant analysis*: Statistically-significant optical parameters that disprove the null hypothesis according to Wilcoxon rank-sum tests were evaluated as to their physiological and photochemical relevance to brain cancer. The selected parameters were used in a linear discriminant analysis (i.e. Fisher's linear discriminant) in order to find the vector in this feature space such that the normal and tumor classes were separated to a maximal extent (at least, in a linear fashion).

[0101] *Receiver-operator characteristic analysis*: The receiver-operator characteristic (ROC) curves were generated using the PpIX concentrations as the parameter comparing normal tissue to these tumor populations: all tumors, all gliomas, low-grade gliomas (LGGs), high-grade gliomas (HGGs), meningiomas and metastases. Optimal sensitivity and specificity values were extracted to determine performance of PpIX concentrations as a tumor-specific marker. The performance of PpIX concentrations as a tumor-specific marker was compared with a metric for the uncorrected, raw fluorescence spectrum (i.e., not corrected for optical properties), and the neurosurgeon's scoring of the visible fluorescence through the surgical microscope (scores are from 0 to 4). The uncorrected fluorescence metric was the magnitude of the PpIX fluorescence peak from the raw fluorescence spectrum, i.e. $F_{x,m}$ at 635 nm (see Eqs. 1 and 4). In this example, the three qF probe measurements at each site were used separately to calculate the ROC curve (rather than averaging the triplicate measurements at each site).

[0102] As well, ROC analysis was performed for the above pathologies using linear discriminant analysis. In other words, multiple variables that can be quantified from the probe data (e.g., PpIX concentration, oxygen saturation, hemoglobin concentration, etc.) were used to attempt to separate the normal and tumor classes to the maximum extent. Since the “training” data set used to train the LDA should not be the same as the “validation” data set used to evaluate the LDA using ROC analysis, a cross-validation algorithm was set up to assess the performance statistics. The cross-validation scheme that was used was repeated random sub-sampling validation. Essentially, half of the data set is randomly sampled and assigned as the training data set to train the LDA. The remaining half is used for validation using ROC analysis. The process was repeated several times and the performance statistics were averaged. In this example, the random sampling process was run 50 times.

Results

[0103] *In vivo probe measurements:* The data fits to the reflectance and fluorescence measurements from the handheld probe during resection surgery were generally good across all tissues. FIG. 18 displays data from an example patient with a high grade glioma (HGG) and an example meningioma patient. Panels (a) and (b) display measurement data in normal tissue (in this case, normal brain parenchyma), while panels (c) and (d) show measurement data from tumor tissue (in this case, a high-grade glioma). Panels (a) and (c) show *in vivo* tissue optical properties spectra, while panels (b) and (d) show reflectance data with model fit. The reflectance model fits very closely to the reflectance measurements. FIG. 19 shows quantitative *in vivo* fluorescence data from an example meningioma patient, as measured using an example handheld fluorescence probe. Panels (a) and (b) show data from the meningioma, while panels (c) and (d) show data from normal dura. Panels (a) and (c) show examples of the quantitative fluorescence measurement and model fit, while panels (b) and (d) show examples of the spectrally unmixed signals. The tumor data show a strong PpIX signal; however, the normal tissue data show AF in the same range as the PpIX signal. These demonstrate the usefulness of accurate AF modeling: in this neurosurgical trial, the AF was modeled as a linear combination of the spectral shapes of flavin adenine dinucleotide, nicotinamide adenine dinucleotide and lipofuscin.

[0104] FIG. 20 exemplifies the additional sensitivity to fluorescence that may be afforded by the disclosed probe as compared to the fluorescence microscope during resection surgery. In FIG. 20, images and measurements were obtained from an example low-grade glioma patient during tumor resection surgery. Panels (a) and (b) display fluorescence images from two sites in the same patient that were both histologically confirmed as tumor. Panels (c) and (d) quantitative fluorescence spectra, obtained using an example fluorescence probe, corresponding to the sites of panels (a) and (b), respectively. The probe measurement sites are indicated by white arrows, and the probe shaft is visible at the point of contact. The first site (panels (a) and (c)) shows visible fluorescence (in this case obtained using an operating microscope), with the surgeon scoring that site as a '2'. This was confirmed by the probe measurement with $[PpIX]=12.9 \mu\text{g/mL}$. However, the second site (panels (b) and (d)), measured after the visible tumor from the first site was removed, has no visible fluorescence (surgeon's score of '0') yet there is a measureable $[PpIX]$ of $0.36 \mu\text{g/mL}$. Both sites were histologically confirmed as tumor tissue.

[0105] FIG. 21 is a table displaying example PpIX concentrations measured *in vivo* by an example probe in normal and tumor tissues for the various pathologies. The table of FIG. 21 shows example comparisons of *in vivo* PpIX concentration levels found in normal and tumor tissues for each of the pathologies in the example study. The tumor-to-normal (T/N) ratios for all pathologies, in this example, are of the same order of magnitude and average out to $T/N = 200$. Standard deviations are indicated by the symbol " \pm ".

[0106] In this example, fifteen optical parameters were tested as to their statistical significance in differentiating between normal and tumor tissue *in vivo*. The table of FIG. 22 shows the list of example diagnostic variables that were tested for significance in differentiating between normal and tumor tissues. In this table, the value h denotes if the null hypothesis has been disproved, with '1' indicating the null hypothesis is not true and '0' indicating it is true. The range of significance levels used to reject the null hypothesis was $p < 0.05$. This analysis was performed for the glioma data set and the all-tumors data set. Partly based on this, $[PpIX]$, AF at 600 nm, the reflectance at both fiber separations at 600 nm, StO_2 and f_{Hb} were used for the multi-variable linear discriminant analysis.

[0107] There may also be physiological and photochemical reasons for these selections for multi-variable linear discriminant analysis. [PpIX] may be the chief tumor biomarker. Autofluorescence (AF) may be tumor-specific, and the autofluorescence at 600 nm (in this example, the shortest wavelength in the fluorescence data collection range) may have the strongest AF signal, since AF may peak in the green region of the spectrum, which is near 600 nm. FIG. 23 shows examples of cluster plots (for the example all-tumors data set and the example HGG data set) with AF on the y -axis and [PpIX] on the x -axis, illustrating (at least qualitatively, visually) that autofluorescence may be useful in separating the normal and tumor data clusters. In FIG. 23, (a) is a plot showing example data for all tumors studied and (b) is a plot showing example data for high-grade gliomas. Reflectance values at 600 nm may be dominated by scattering, which in turn may be affected by cell organelle size and morphology. Reflectance measurements at the two fiber separations may contain encoded information on not only the reduced scattering coefficient, but also the scattering phase function. Finally, f_{Hb} and StO_2 may be diagnostically useful in distinguishing between glioma and normal tissues.

ROC analysis of the in vivo probe data

[0108] FIG. 24 displays the example ROC curves for (a) the *in vivo* all-tumors data set and (b) the *in vivo* HGG data set. In FIG. 24, the example diagnostic variables considered were: the surgeon's visible fluorescence score as determined through the surgical microscope; the PpIX peak (e.g., 635 nm) fluorescence magnitude from the raw, uncorrected fluorescence spectrum; PpIX concentration; and a metric derived from linear discriminant analysis. In this example, the raw uncorrected fluorescence measurement at the 635 nm PpIX peak performed the worst of the variables studied. The surgeon's subjective fluorescence scoring was better than the raw fluorescence metric. Note that the surgeon in this example study was relatively experienced with ALA-PpIX FGR, so the good performance of the subjective fluorescence scoring result may be unrepresentative. However, the quantitative [PpIX] metric performed better than the surgeon's scoring, with the LDA model improving the tumor detection accuracy.

[0109] FIGS. 25-29 displays example ROC *in vivo* data, including the ROC area under the curve (a.u.c.) data, sensitivity and specificity values for: the all-tumors (FIG. 25), HGG (FIG. 26), LGG (FIG. 27), intracranial lung metastasis tumors (FIG. 28) and meningioma (FIG. 29) data

sets. In this example study, for all tissue types with the exception of metastatic tumors, the general trend holds that the order of increasing performance is: raw fluorescence at 635 nm, surgeon's score, [PpIX] and then LDA. For the lung metastatic tumor data, the ROC area-under-curve is slightly higher for [PpIX] than the LDA classifier, though both these have better performance than the surgeon's score and raw fluorescence metric.

[0110] *Conclusion:* In this example study an intraoperative fiber-optics probe was used to estimate PpIX concentrations *in vivo* during clinical intra-cranial resection procedures. Spectrally-dependent endogenous optical properties (e.g., absorption, scattering) were computed for each light collection point and used as prior information in an algorithm designed to estimate PpIX concentrations from measured fluorescence spectra.

[0111] There may be several clinical rationales for using an example of the described probe. For example, it may be used to overcome limitations of conventional fluorescence imaging techniques and instruments used (such as the lack of quantification of the fluorescence signal in a typical imaging system), for example, for surgical guidance. Thus, an example of the probe may be used to detect lower concentrations of fluorophore in tissue and provide better discrimination from the autofluorescence tissue background. An example of the probe may also provide quantitative and absolute measurements of the fluorophore concentration in the tissue. An example of the probe may also provide relatively highly localised measurements, which may be at the tissue surface or at depth. For example, depth measurements may be acquired by positioning the probe tip interstitially through the tissue, to allow interstitial measurements to be taken.

[0112] The example study described above shows evidence that probe measurements may confer greater sensitivity than the surgical microscope in detecting a significant amount of PpIX fluorescence in abnormal tissue compared to normal. In instances of no visible fluorescence as determined through the surgical microscope, probe estimates of PpIX concentrations in this study showed approximately at least five times more PpIX in abnormal tissue compared to normal tissue. It may also be useful to corroborate the diagnostic capabilities of using probe estimates of PpIX concentration as an intraoperative diagnostic tool for delineating tumor margins in ALA-PpIX FGR. This example study illustrates that quantitative measurements using

the example probe may be sensitive enough to detect a significant difference between abnormal tissue (e.g., tissue with the presence of tumor cells and/or reactive changes) and normal tissue. It may be useful to note that these reactive changes may be present in the peritumoral regions and as such may provide preliminary data regarding the probe's ability to detect PpIX differences at the farthest extent of tumor margins. To summarize, the results of this example study may provide data to support using spectroscopically estimated PpIX concentrations for tumor margin delineation and *in vivo* diagnosis.

[0113] The diagnostic accuracy of the example probe may be further improved by considering diagnostic variables other than PpIX concentration. For example, other metrics such as reflectance, oxygen saturation, hemoglobin concentration and/or autofluorescence may be included in the diagnostic determination. FIGS. 24-29 show examples of how a diagnostic determination taking multiple diagnostic variables into account may be useful (in these example figures, linear discriminant analysis was found to generally have a relatively good diagnostic result).

Applications

[0114] The example device and system described, and associated model and method may provide useful diagnostic techniques for the operating room. For example, the fiberoptic probe may be useful as an intraoperative diagnostic tool for delineating brain tumor margins. For example, FIG. 20, panels (a) and (b) illustrate the use of the probe in a tumor site. The probe measurement sites are indicated by white arrows, and the probe shaft is visible at the point of contact.

[0115] There may be a number of biomedical applications for *in situ* quantitative fluorescence spectroscopy using the described device, system and method. Although the above discussion focused primarily on the use of the example fiberoptic probe to delineate glioma tumor margins during resection surgery, the probe can be used for general optical diagnosis or monitoring of tissue disease states or normal physiology. Endogenous and exogenous fluorescence contrast has been explored to detect and diagnose diseased tissue. Since tissue optical properties and measurement geometry may significantly affect the fluorescence signal, it is useful for these

distorting effects be removed. The disclosed device, system and method may therefore be useful for improving current efforts to correctly diagnose or monitor tissue using fluorescence.

[0116] Another potential application is the evaluation of drug biodistribution and time kinetics in patients and pre-clinical animal models. It is often useful to know how a drug is distributed in various organs and pathological tissues for diagnostic, therapeutic or response monitoring clinical applications. Many diagnostic and therapeutic photosensitizing drugs are fluorescent, such as protoporphyrin IX (PpIX), Photofrin and benzoporphyrin derivative. Alternatively, the drug may happen to be fluorescent despite the clinical application of the drug being unrelated to fluorescence: for example, the chemotherapy drugs taxol, cyclophosphamide and doxorubicin are fluorescent. Alternatively, a drug may be made fluorescent by tagging it with a fluorescent reporter, such as binding fluorescent molecules (or molecular beacons, or nanoparticles) to chemotherapy drugs, heart medication, or other medications. It is a common goal in pre-clinical studies to measure drug content in various organs to determine the safety and efficacy of the drug. The example device and system may be useful to determine the time kinetics and biodistribution of such fluorescing drugs, such as a recent pre-clinical study done in our labs with a porphyrin dimer-based drug for two-photon absorption photodynamic therapy of melanoma tumors.

[0117] The fiberoptic probe can also be used to monitor photodynamic therapy (PDT). There are several physiological parameters that may be used to dynamically monitor PDT, such as tissue oxygenation, fluorescent drug concentration, *etc.* Another form of implicit PDT monitoring may be based on monitoring the generation of photoproducts of the therapy drug. PpIX has known photoproducts with spectral peaks distinct from the original fluorophore. PpIX photoproduct generation has been shown due to unintentional photodynamic therapy of brain tumors by the illumination from the neurosurgical microscope. This phenomenon may also be a useful metric for monitoring of PDT (*i.e.* done intentionally). Implicit PDT monitoring of oxygen and drug depletion may aid in reducing patient-to-patient variability.

[0118] In some examples, the present disclosure may be useful for radiation therapy, for example to detect target tissue for treatment and/or to assist in identifying tumor tissue for designing a radiation treatment plan. The present disclosure may also be useful for delineating

margins in various tumor sites including, for example, the head and neck, the prostate, the breast, skin, and other sites.

[0119] This technique may be expanded to non-biological or non-living tissue applications, for example where fluorescence quantification may be used to test optically-turbid, fluorescent materials. Examples of such materials include but are not limited to: pulp and paper, food and beverage, paint making, plastics, lumber, food safety (*e.g.*, detection of food-borne bacteria or pathogens that may be fluorescent or made to be fluorescent), and pharmaceuticals (*e.g.* pills). Fluorescence quantification may be used for quality control of materials or for human safety purposes.

[0120] There may be additional functionality applied to the fiberoptic probe. A switch on the probe or a foot pedal may be added to trigger data acquisitions. As well, the measurement cycle and algorithm computation schematically represented in FIG. 9 may be run continuously to provide real-time information to the operator. The example shown in FIG. 9 includes measurement of: the fluorescence spectrum (at one fiberoptic distance), the reflectance spectr(a)um (at one or multiple fiberoptic distances) and the background ambient light. The diagram also outlines the example algorithm to compute the optical properties, quantitative fluorescence and fluorophore concentrations, to be elucidated in the detailed description section.

[0121] Optical tracking or electromagnetically tracking sensors may be placed on the probe to track its position and orientation with reference to other imaging modalities and surgical tools. One example with regard to surgical tumor resection is to use position tracking sensors to track the probe within a surgical cavity (*e.g.*, a brain cavity) with reference to pre-operative MRI or CT, to correlate fluorescence point measurements with tomographic information.

[0122] Other techniques may be used to estimate the optical properties. For example, in the UV-blue region, hemoglobin absorption may be significant, so a photothermal technique (such as pulsed-photothermal radiometry or photoacoustic spectroscopy) may be used to measure the excitation absorption and scattering. Photothermal optical properties measurements have a larger dynamic range than diffuse reflectance for measuring absorption because in the former, optical absorption adds to the measurement signal whereas in the latter, absorption subtracts from the

signal, which makes the maximum measurable absorption restricted by the signal-to-background contrast.

[0123] The described device, system and methods may be used where fluorescence emission is detected from a fluorescence marker, including, for example: protoporphyrin IX (PpIX) (including ALA-induced PpIX) and indocyanine green (ICG). Other suitable fluorescence markers may include, for example: an organic fluorophore (e.g., nicotinamide adenine dinucleotide, flavin adenine dinucleotide, or collagen), a nanoparticle-based agent (e.g., a quantum dot, or a nanoparticle carrying a fluorescent agent.), fluorescein and a fluorescent molecular beacon (e.g., based on enzymatic cleavage or antisense hybridization). The fluorescence marker may be targeted to a tissue of interest using a targeting moiety, such as an antibody or a peptide. The fluorescence marker may alternatively be untargeted. In some examples, the fluorescence marker may be fluorescein (e.g., for marking disrupted blood-brain barrier of a brain tumor).

[0124] Although certain examples have been described, these are for the purpose of illustration only and are not intended to be limiting. Variations, combinations, and equivalents of the specific embodiment, method, and examples herein may be possible. Features described in separate examples may be used in combination. Specific values and sub-ranges within disclosed ranges are also disclosed. The present disclosure is not necessarily bound by any theory or assumptions described by way of example. All references mentioned are hereby incorporated by reference in their entirety.

References

[0125] 1. K.R. Diamond, M.S. Patterson, T.J. Farrell. "Quantification of fluorophore concentration in tissue-simulating media by fluorescence measurements with a single optical fiber," *Appl. Opt.* **42**(13), 2436-2442 (2003).

[0126] 2. J.C. Finlay, T.C. Zhu, A. Dimofte, D. Stripp, S.B. Malkowicz, T.M. Busch, S.M. Hahn. "Interstitial Fluorescence Spectroscopy in the Human Prostate During Motexafin Lutetium-Mediated Photodynamic Therapy," *Photochem. Photobiol.* **82**(5), 1270-1278 (2006).

- [0127] 3. S.T. Flock, M.S. Patterson, B.C. Wilson, D.R. Wyman. "Monte-Carlo modeling of light-propagation in highly scattering tissues: 1. Model predictions and comparison with diffusion-theory," IEEE Trans. Biomed. Eng. **36**(12), 1162-1168 (1989).
- [0128] 4. F.A.J. Groenhuis, H.A. Ferwerda, J.J. ten Bosch. "Scattering and absorption of turbid materials derived from reflection coefficients. 1: Theory," Appl. Opt. **22**(16), 2456-2462 (1983).
- [0129] 5. L. Lilge, C. O'Carroll, B.C. Wilson. "A solubilization technique for photosensitizer quantification in *ex vivo* tissue samples," J. Photochem. Photobiol. B **39**(3), 229-235 (1997).
- [0130] 6. M.G. Müller, I. Georgakoudi, Q. Zhang, J. Wu, M.S. Feld. "Intrinsic fluorescence spectroscopy in turbid media: disentangling effects of scattering and absorption," Appl. Opt. **40**(25), 4633-4646 (2001).
- [0131] 7. R. Sroka, W. Beyer, L. Gossner, T. Sassy, S. Stocker, R. Baumgartner. "Pharmacokinetics of 5-aminolevulinic-acid-induced porphyrins in tumour-bearing mice," J. Photochem. Photobiol. B, Biology **34**(1), 13-19. (1996).
- [0132] 8. W. Stummer, H. Stepp, G. Moller, A. Ehrhardt, M. Leonhard, H.J. Reulen. "Technical principles for protoporphyrin-IX-fluorescence guided microsurgical resection of malignant gliomas tissue," Acta Neurochir. **140**(10), 995-1000 (1998).
- [0133] 9. R. Weersink, M.S. Patterson, K. Diamond, S. Silver, N. Padgett. "Noninvasive measurement of fluorophore concentration in turbid media with a simple fluorescence/reflectance ratio technique," Appl. Opt. **40**(34): 6389-6395 (2001).
- [0134] 10. J. Wu, M.S. Feld, R.P. Rava. "Analytical model for extracting quantitative fluorescence in turbid media," Appl. Opt. **32**, 3585-3595 (1993).

Claims

1. An optical probe for quantifying fluorescence and optical properties in tissue, the probe comprising:

a probe body and a probe tip at a distal end of the probe body, the probe tip being configured to substantially contact a target surface;

at least one detector at the probe tip for detecting fluorescence emission or reflectance wavelengths from the target surface;

at least one fluorescence excitation source at the probe tip for providing fluorescence excitation light to the target surface, each one of the at least one fluorescence excitation source being at a known distance from each one of the at least one detector;

at least two broadband sources at the probe tip for providing broadband wavelengths to the target surface, each one of the at least two broadband sources being at a known distance from each one of the at least one detector;

wherein the device is configured to communicate signals from the at least one detector representing the detected wavelengths to a processing device.

2. The probe of claim 1 wherein at least one of the broadband sources is at a distance from the at least one detector that is the same as a distance between the at least one fluorescence excitation source and the at least one detector.

3. The probe of claim 2 wherein there is one detector, one fluorescence excitation source at a distance of about 260 micrometers from the detector, and two broadband sources at a distance of about 260 micrometers and about 520 micrometers, respectively, from the detector.

4. The probe of any one of claims 1 to 3 wherein the fluorescence excitation source is configured to provide fluorescence excitation light in the range of about 350 nm to about 600 nm.

5. The probe of claim 4 wherein the fluorescence excitation source is configured to provide fluorescence excitation light in the range of about 500 nm to about 600 nm.
6. The probe claim 4 wherein the fluorescence excitation source is configured to provide fluorescence excitation light in the range of about 380 nm to about 420 nm.
7. The probe of any one of claims 1 to 6 wherein the detector is configured to detect emission or reflectance wavelengths in the range of about 450 to about 850 nm.
8. The probe of any one of claims 1 to 7 wherein the probe tip has an angled or tapered configuration.
9. The probe of any one of claims 1 to 8 wherein there is a plurality of fluorescence excitation sources at the probe tip, each of the plurality of fluorescence excitation sources providing a different range of fluorescence excitation wavelengths.
10. The probe of any one of claims 1 to 9 wherein the target surface is a tissue surface located interstitially within the tissue.
11. A method for quantifying optical properties in a turbid medium, the method comprising:

providing fluorescence emission and reflectance wavelengths detected from a target surface, each of the detected wavelengths being associated with a respective known distance between a respective excitation source giving rise to the respective detected wavelength and a detector detecting the respective detected wavelength, the known distances being predetermined to enable calculation of a desired range of values for the optical properties; and

calculating the optical properties based on the detected wavelengths and the respective known distances, and based on a model of light interaction with the turbid medium, the model limiting a range of calculated values for the optical properties.
12. The method of claim 11 wherein there are at least two reflectance wavelengths having different respective known distances between the excitation sources and the detector; and

wherein at least one of the at least two reflectance wavelengths has a respective known distance equal to a respective known distance for at least one emission wavelength.

13. The method of claim 11 or claim 12 further comprising selecting the reflectance wavelengths for calculating the optical properties, and comparing the reflectance wavelengths with one of: a known absorption spectrum and fluorescence quantum yield of a fluorophore; and a measurement in the turbid medium of a known fluorophore concentration.

14. The method of any one of claims 11 to 13 further comprising calculating a quantitative fluorescence spectrum with the calculated optical properties used in a corrective algorithm.

15. The method of claim 14 further comprising calculating fluorophore concentrations using spectral decomposition of the quantitative fluorescence spectrum.

16. The method of any one of claims 11 to 15 wherein the detected wavelengths include detected emission wavelengths from a fluorescence marker.

17. The method of claim 16 wherein the fluorescence marker is one of: protoporphyrin IX (PpIX) and indocyanine green (ICG).

18. The method of claim 17 wherein the PpIX is aminolevulinic acid (ALA)-induced PpIX.

19. The method of claim 16 wherein the fluorescence marker is one of: an organic fluorophore, a nanoparticle-based agent, fluorescein and a fluorescent molecular beacon.

20. The method of claim 19 wherein the organic fluorophore is one of: nicotinamide adenine dinucleotide, flavin adenine dinucleotide, and collagen.

21. The method of claims 19 wherein the nanoparticle-based agent is one of: a quantum dot, and a nanoparticle carrying a fluorescent agent.

22. The method of claim 19 wherein the fluorescent molecular beacon is based on enzymatic cleavage or antisense hybridization.

23. The method of any one of claims 16 to 22 wherein the fluorescence marker is targeted to a tissue of interest using a targeting moiety.

24. The method of claim 23 wherein the targeting moiety is an antibody or a peptide.
25. The method of any one of claims 16 to 22 wherein the fluorescence marker is untargeted.
26. The method of claim 16 wherein the fluorescence marker is fluorescein for marking disrupted blood-brain barrier of a brain tumor.
27. The method of any one of claims 11 to 26 wherein the turbid medium is tissue.
28. A method for quantifying fluorescence in a turbid medium, the method comprising:

providing fluorescence emission and reflectance wavelengths detected from a target surface, each of the detected wavelengths being associated with a respective known distance between a respective excitation source giving rise to the respective detected wavelength and a detector detecting the respective detected wavelength, the known distances being predetermined to correspond to a desired range of values for the optical properties;

providing quantified optical properties corresponding to the detected wavelengths; and

calculating the fluorescence based on the detected wavelengths and the corresponding optical properties, based on known relationships between the detected emission wavelengths and the detected reflectance wavelengths arising from the known distances, and based on a model of light interaction with the turbid medium, the model limiting a range of calculated values for the optical properties.
29. The method of claim 28 wherein the quantified optical properties are provided by the method of any one of claims 11 to 27.
30. The method of claim 28 or claim 29 further comprising calculating fluorophore concentrations using spectral decomposition of the calculated fluorescence.
31. The method of any one of claims 28 to 30 wherein the detected wavelengths include detected emission wavelengths from a fluorescence marker.

32. The method of claim 31 wherein the fluorescence marker is one of: protoporphyrin IX (PpIX) and indocyanine green (ICG).
33. The method of claim 32 wherein the PpIX is aminolevulinic acid (ALA)-induced PpIX.
34. The method of claim 31 wherein the fluorescence marker is one of: an organic fluorophore, a nanoparticle-based agent, fluorescein and a fluorescent molecular beacon.
35. The method of claim 34 wherein the organic fluorophore is one of: nicotinamide adenine dinucleotide, flavin adenine dinucleotide, and collagen.
36. The method of claims 34 wherein the nanoparticle-based agent is one of: a quantum dot, and a nanoparticle carrying a fluorescent agent.
37. The method of claim 34 wherein the fluorescent molecular beacon is based on enzymatic cleavage or antisense hybridization.
38. The method of any one of claims 31 to 37 wherein the fluorescence marker is targeted to a tissue of interest using a targeting moiety.
39. The method of claim 38 wherein the targeting moiety is an antibody or a peptide.
40. The method of any one of claims 31 to 37 wherein the fluorescence marker is untargeted.
41. The method of claim 31 wherein the fluorescence marker is fluorescein for marking disrupted blood-brain barrier of a brain tumor.
42. The method of any one of claims 28 to 41 wherein the turbid medium is tissue.
43. The method of any one of claims 28 to 42 further comprising calibrating the detector using a phantom to provide a reference fluorescence measurement for calculating the fluorescence.
44. The method of claim 43 wherein calibrating the detector is performed immediately prior to a surgical procedure.
45. The method of claim 44 wherein the phantom is a solid sterilizable phantom.

46. A system for quantifying optical properties in tissue, the system comprising:
- the probe of any one of claims 1 to 10;
- a plurality of light sources for providing fluorescence and broadband wavelengths to the fluorescence excitation source and broadband sources;
- a spectrometer for measuring wavelengths detected by the detector; and
- a controller for controlling emission and detection by the sources and the detector;
- wherein the system is in communication with a processing device configured for calculating at least one optical property based on the measured wavelengths.
47. The system of claim 46 wherein the processing device is configured to carry out the method of any one of claims 11 to 45.
48. The system of claim 46 or claim 47 wherein the system comprises the processing device.
49. A use of the device of any one of claims 1 to 10 or the system of any one of claims 46 to 48 for quantifying fluorescence and optical properties in tissue.
50. The use of claim 49 wherein the tissue is a tumor tissue.
51. The use of claim 49 or claim 50 for performing a diagnosis of the tissue based on the quantified fluorescence and optical properties of the tissue.
52. The use of claim 51 wherein the diagnosis is further based on at least one additional measurement from the tissue.
53. The use of claim 52 wherein the at least one additional measurement is at least one of: a reflectance measurement, an oxygen saturation measurement, a hemoglobin concentration measurement, and an autofluorescence measurement.
54. A use of the device of any one of claims 1 to 10 or the system of any one of claims 46 to 48 for quantifying fluorescence and optical properties in a non-biological target.

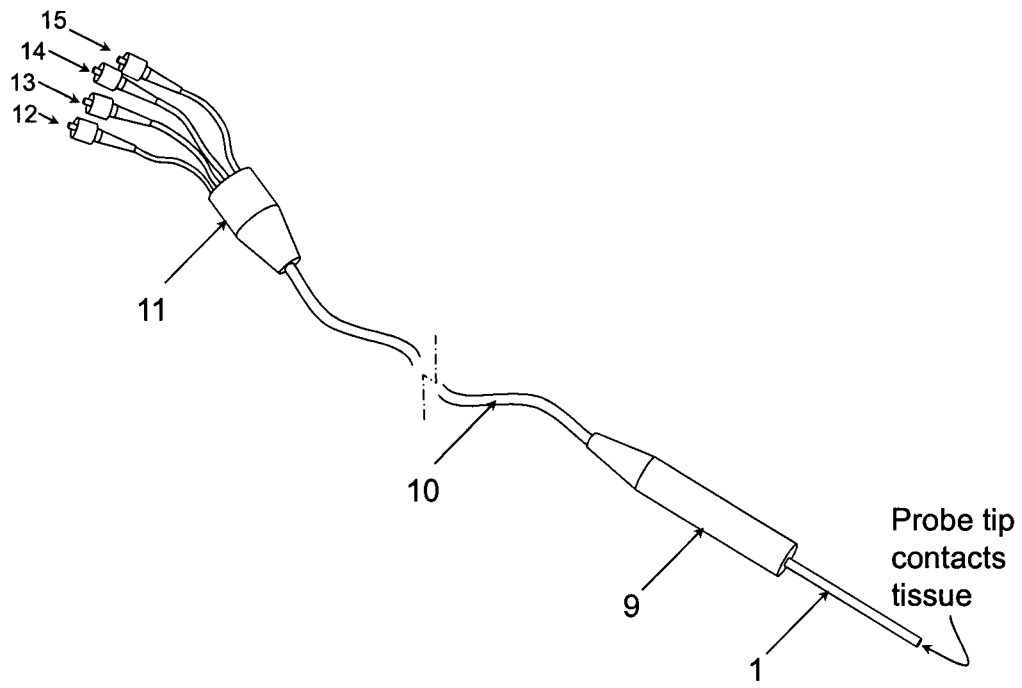

FIG. 1

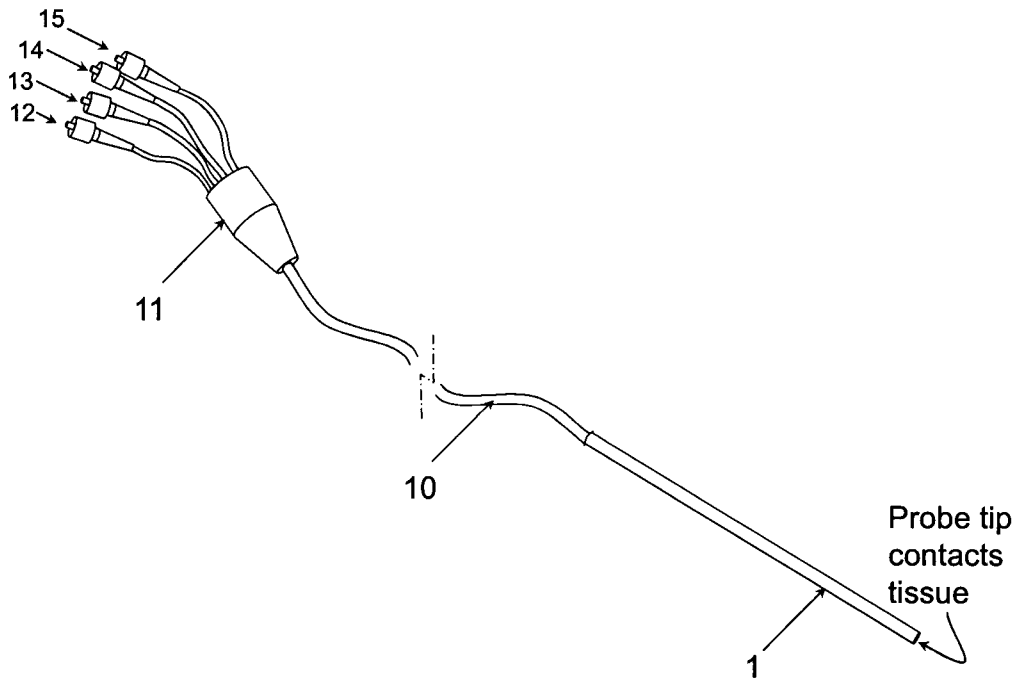

FIG. 2

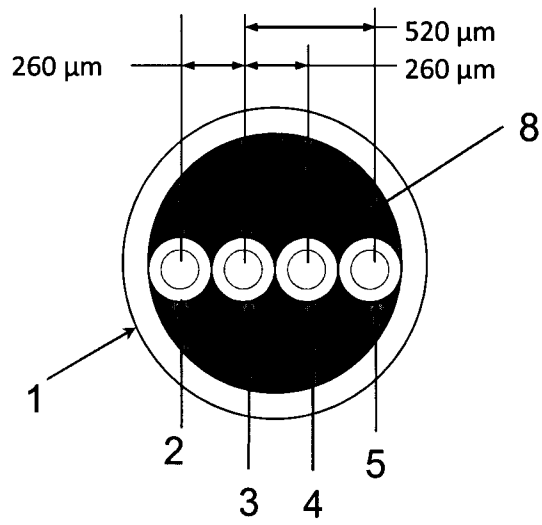

FIG. 3

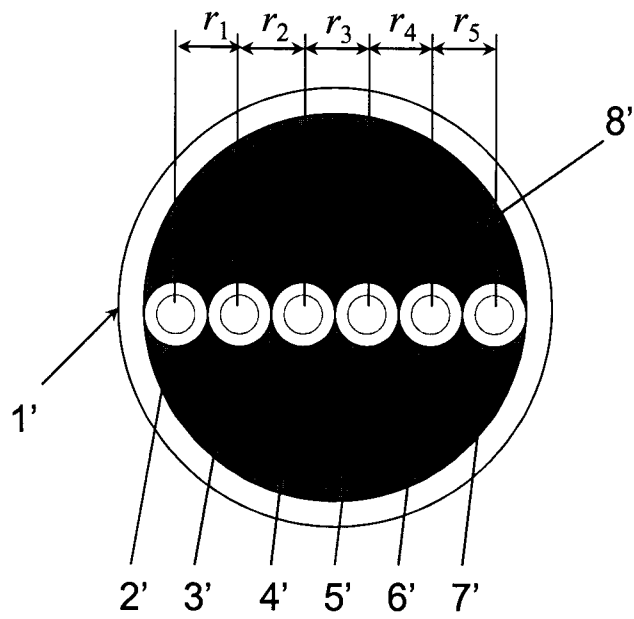

FIG. 4

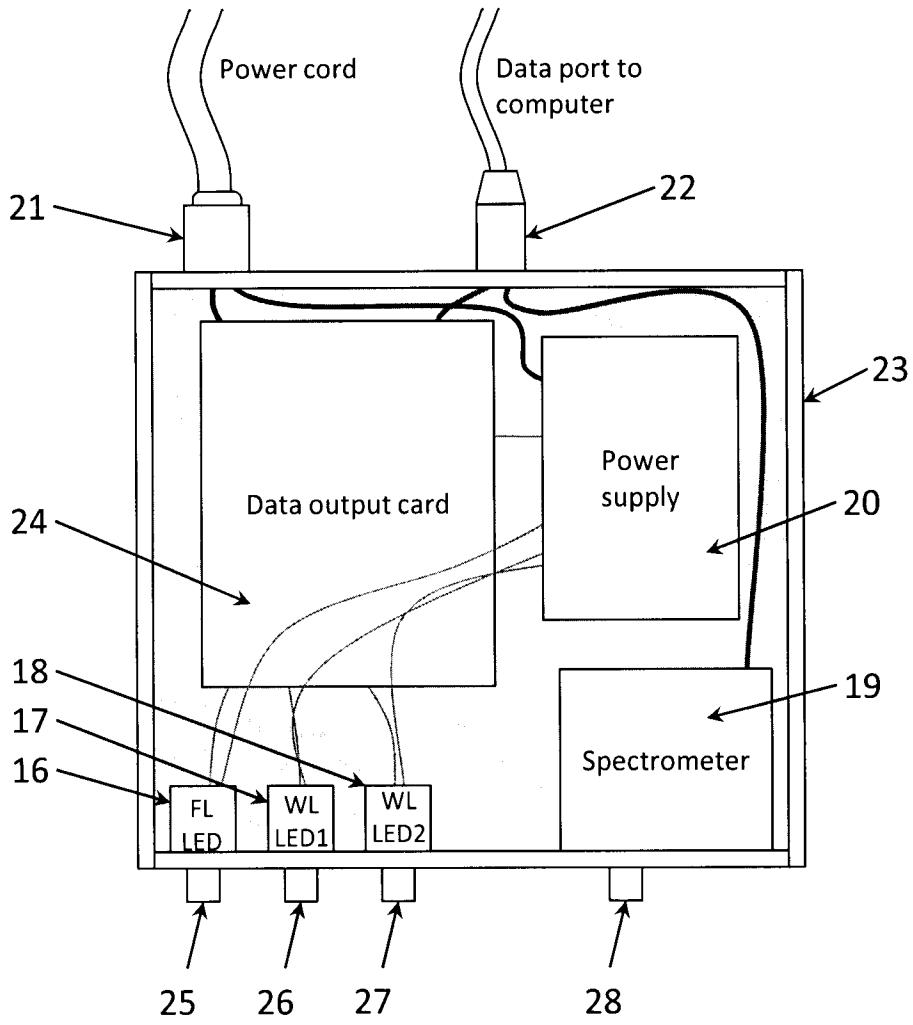

FIG. 5

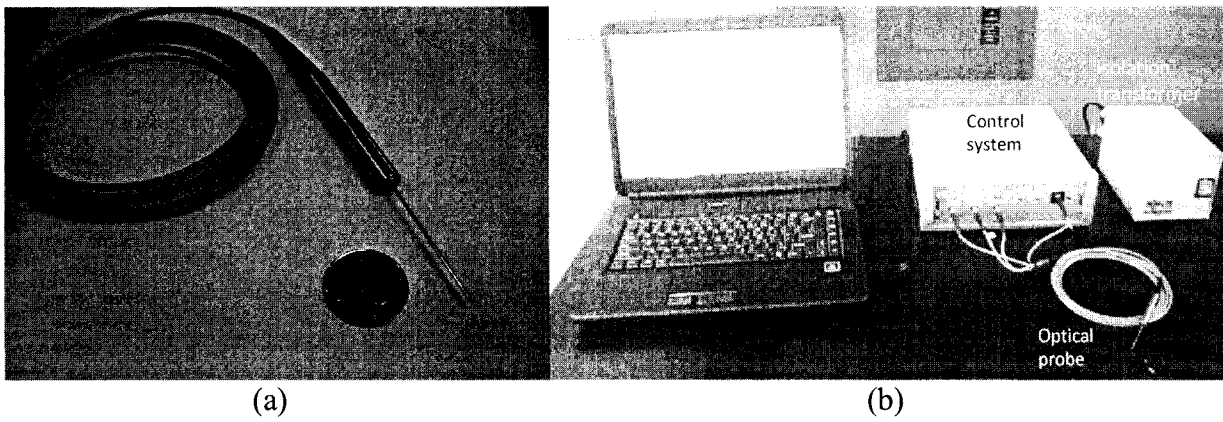

FIG. 6

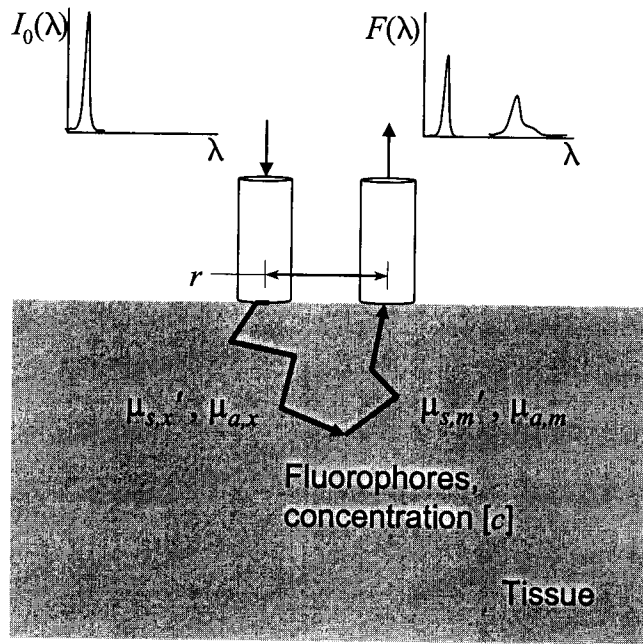

FIG. 7

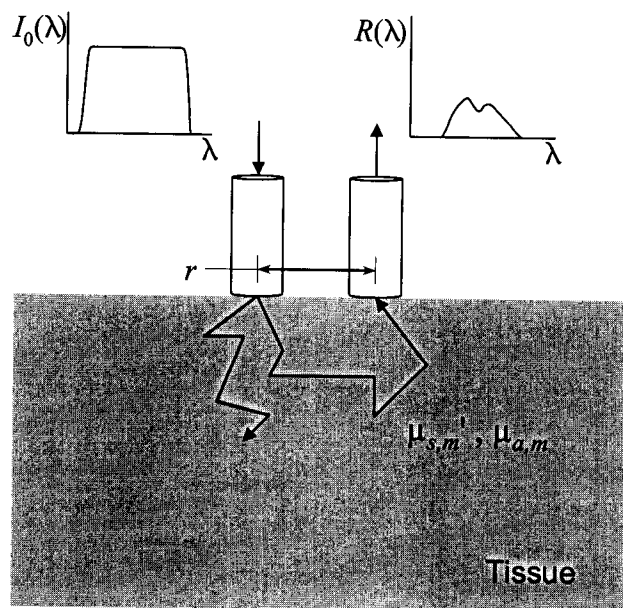

FIG. 8

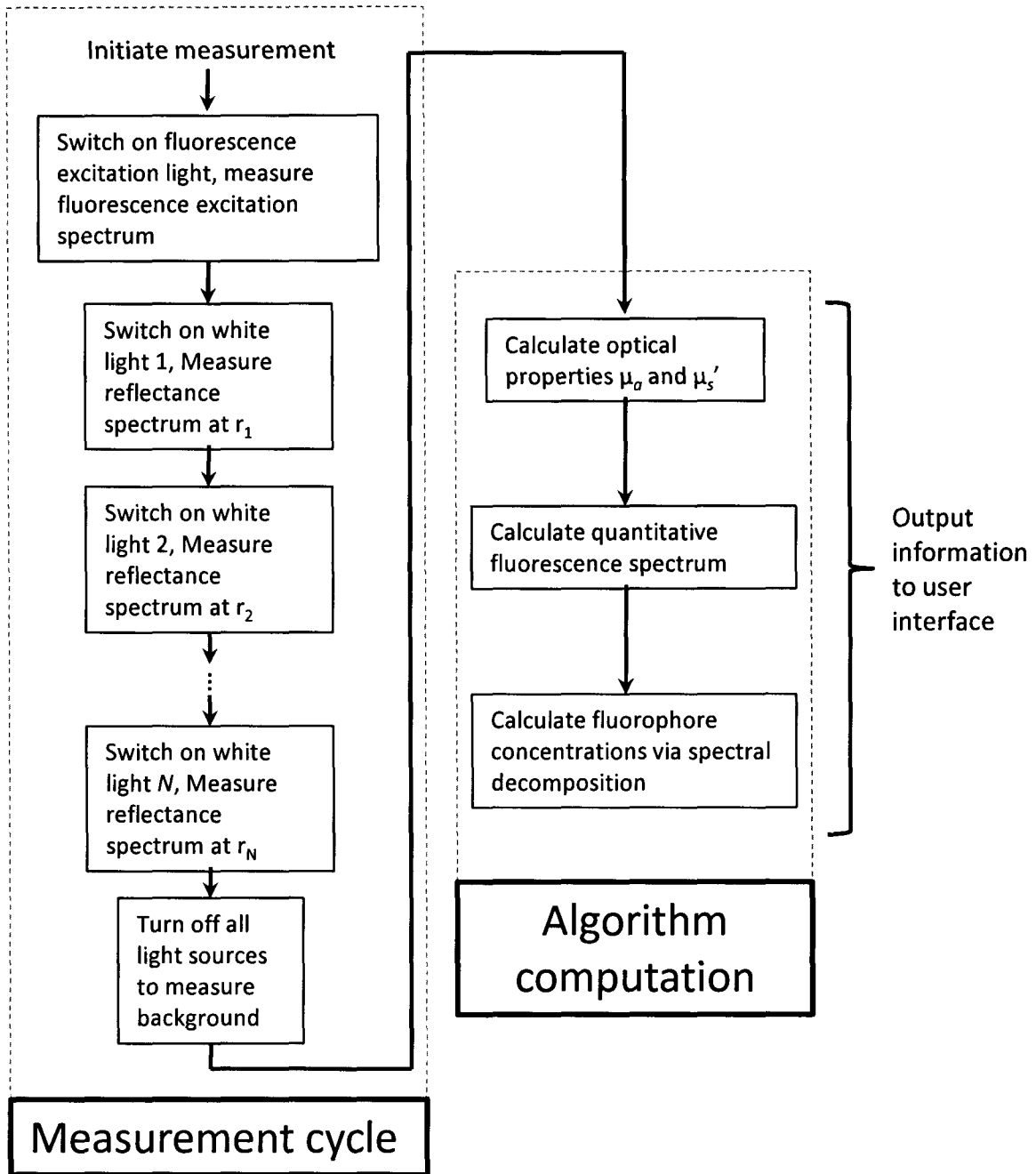

FIG. 9

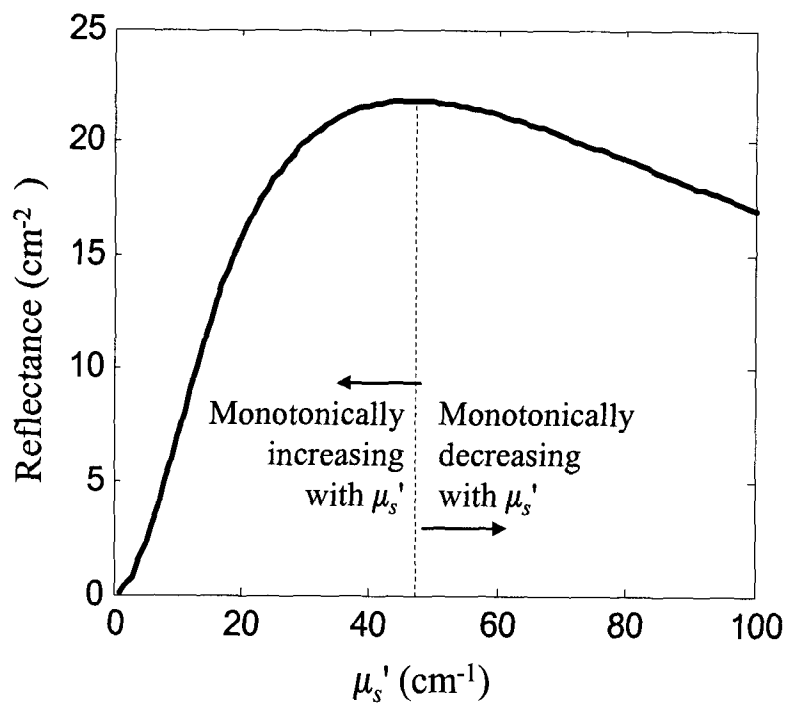

FIG. 10

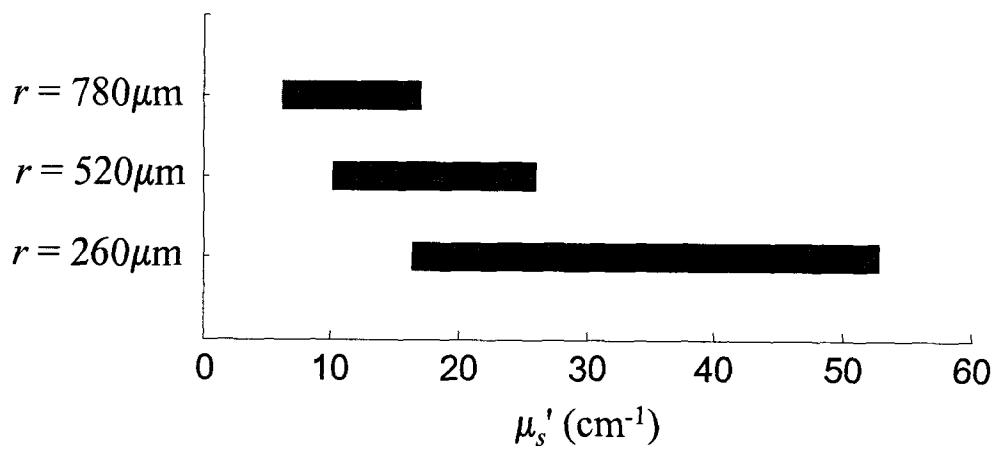

FIG. 11

	$\mu_{a,x}$ (cm^{-1})	$\mu_{s,x}$ (cm^{-1})	$\mu_{a,m}$ (cm^{-1})	$\mu_{s,m}$ (cm^{-1})
Phantom A	20	15	0.02	8.7
Phantom B	20	20	0.02	11.6
Phantom C	20	25	0.02	14.5
Phantom D	40	15	0.04	8.7
Phantom E	40	20	0.04	11.6
Phantom F	40	25	0.04	14.5
Phantom G	60	15	0.06	8.7
Phantom H	60	20	0.06	11.6
Phantom I	60	25	0.06	14.5

FIG. 12

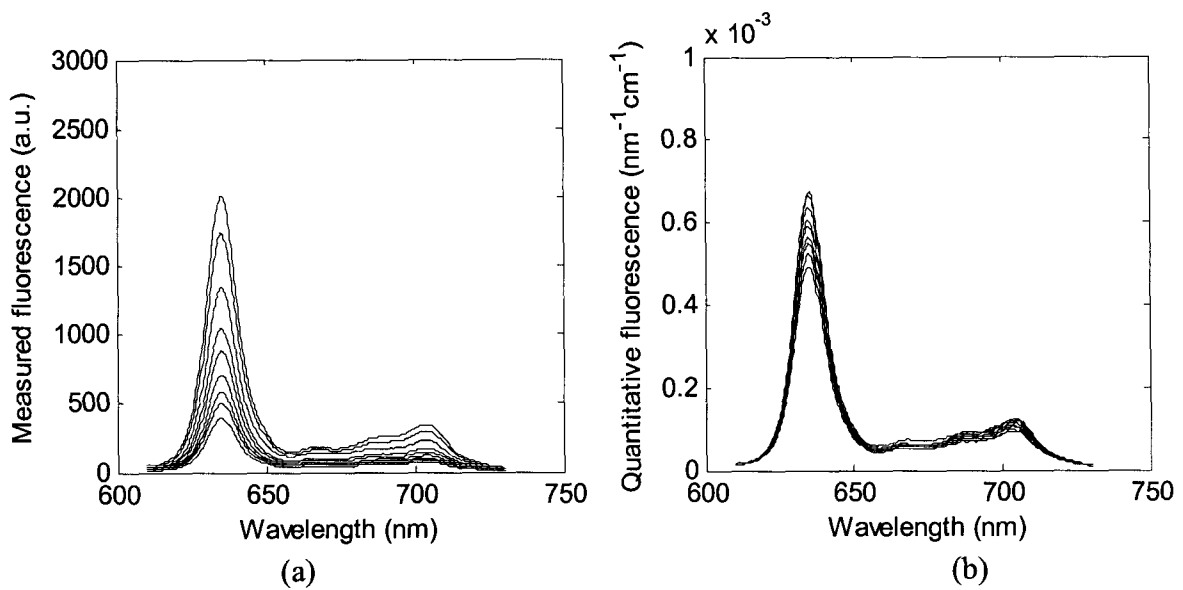

FIG. 13



FIG. 14

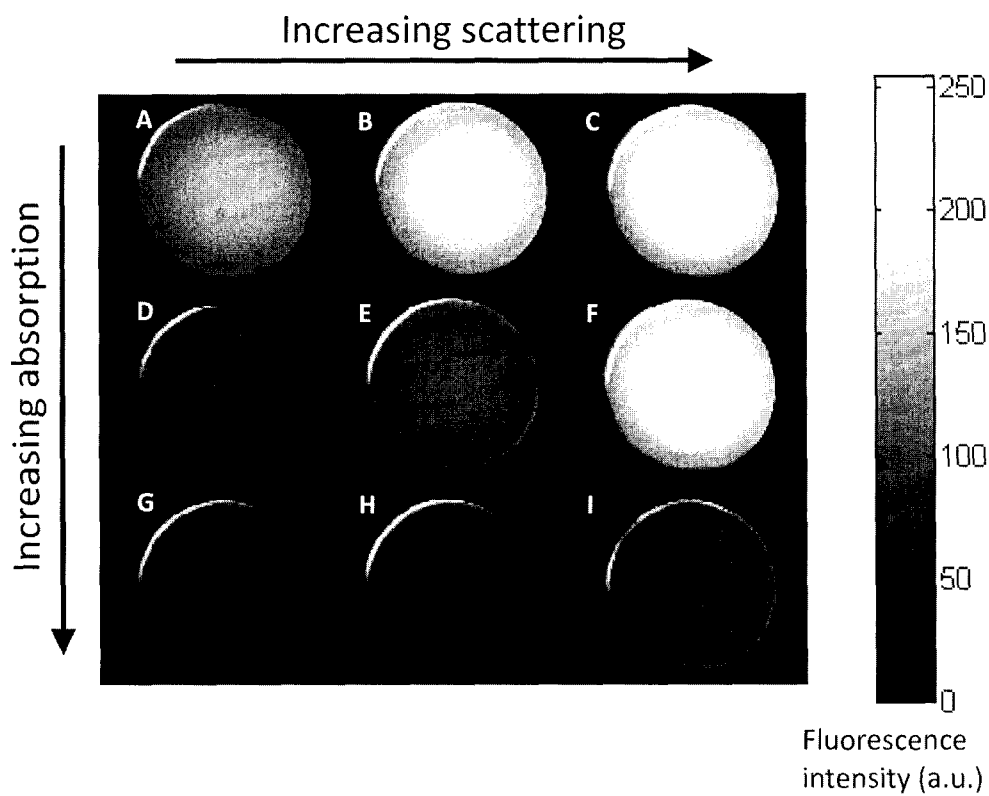

FIG. 15

(a)

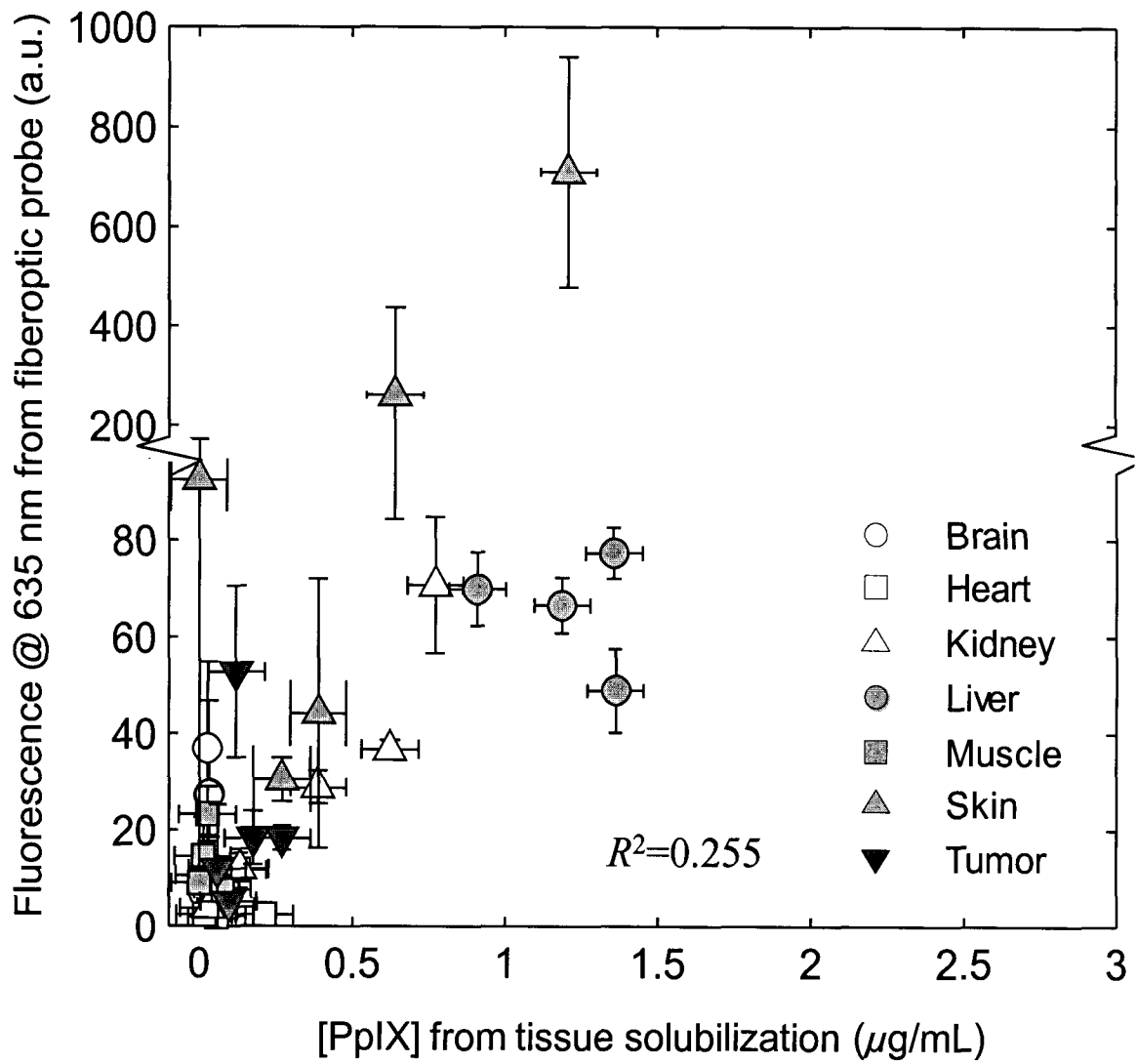

FIG. 16A

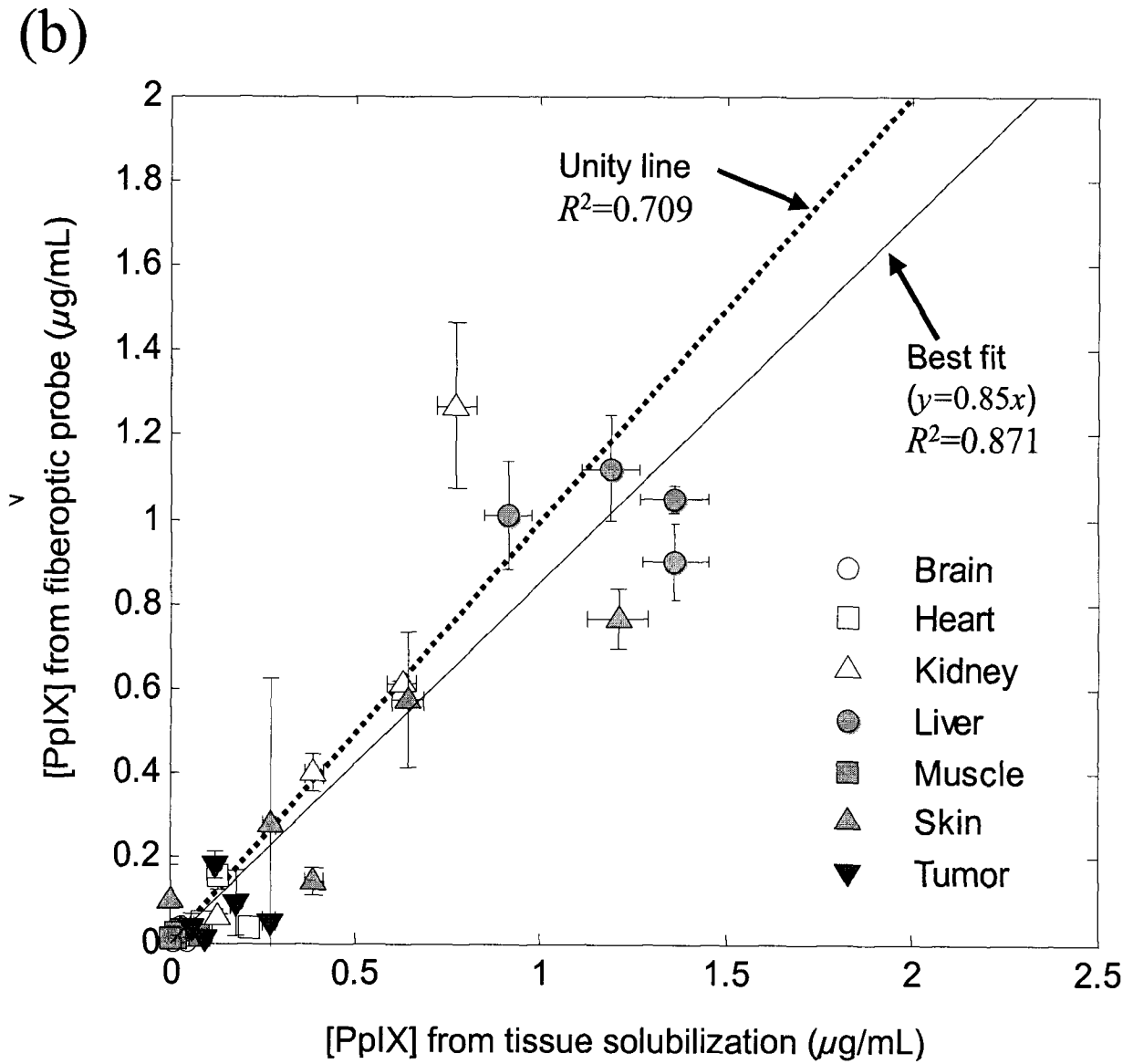

FIG. 16B

Pathology	Patients	# of control sites	# of tumor sites
Low-Grade Glioma	2	4	12
High-Grade Glioma	3	8	20
Meningioma	6	13	20
Lung metastasis	3	12	12

FIG. 17

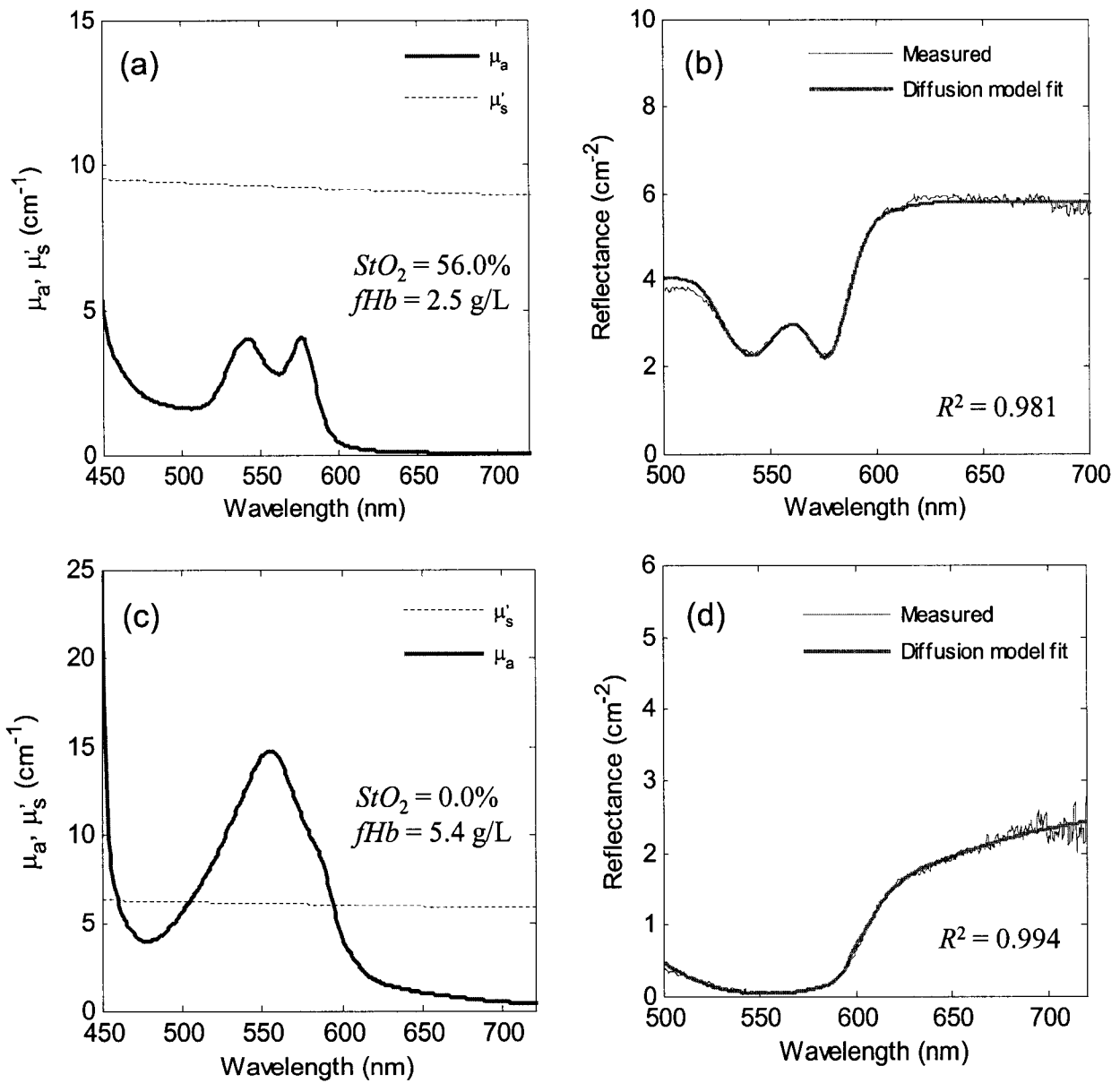

FIG. 18

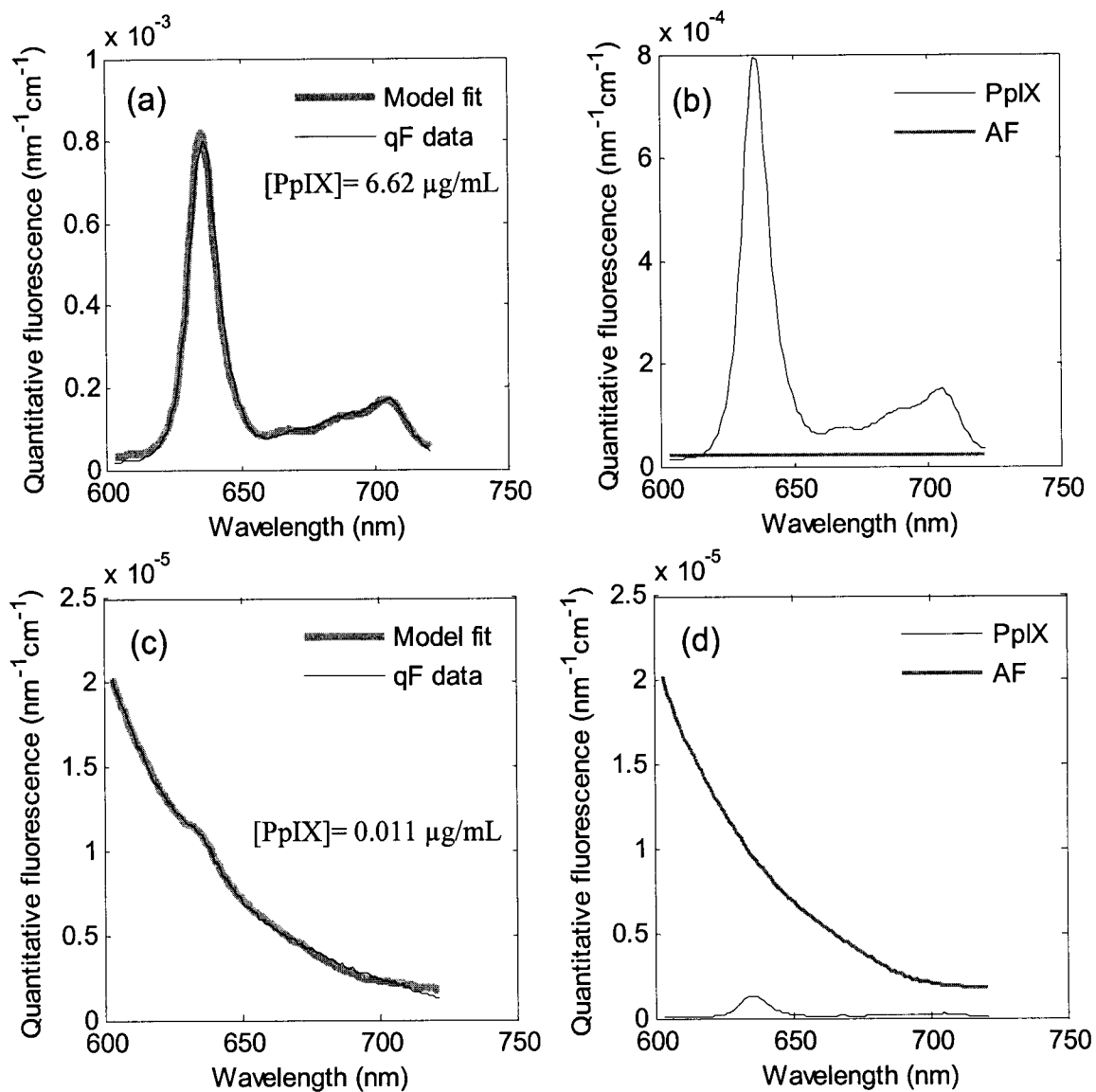

FIG. 19

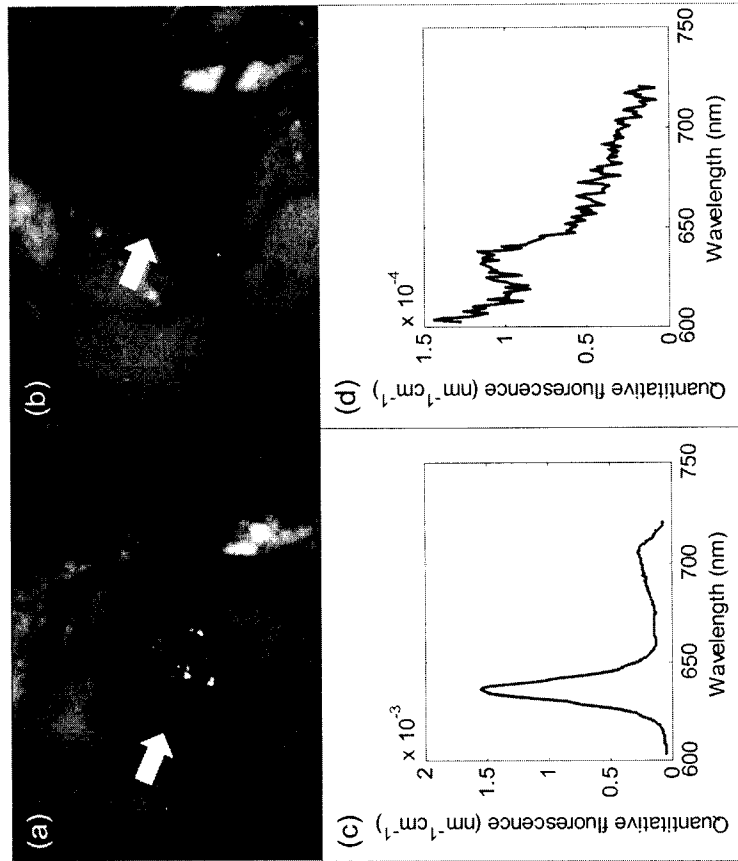

FIG. 20

12.9 ug/mL 0.36 ug/mL

	[PpIX] ($\mu\text{g/mL}$) Normal tissue	[PpIX] ($\mu\text{g/mL}$) Tumor tissue	[PpIX] T/N ratio (based on averages)
All tumors	0.008 ± 0.018	1.27 ± 3.78	155
LGGs	0.004 ± 0.002	0.98 ± 3.22	266
HGGs	0.007 ± 0.007	1.48 ± 5.56	225
Meningioma	0.014 ± 0.028	1.59 ± 2.89	116
Metastasis	0.003 ± 0.005	0.66 ± 0.96	222

FIG. 21

Diagnostic variable	Using <i>in vivo</i> glioma data		Using <i>in vivo</i> all-tumors data	
	<i>p</i>	<i>h</i> (<i>h</i> =1 if <i>p</i> <0.05)	<i>p</i>	<i>h</i> (<i>h</i> =1 if <i>p</i> <0.05)
[PpIX] (μg/mL)	<0.001	1	<0.001	1
AF (λ=600 nm) (nm ⁻¹ ·cm ⁻¹)	0.346	0	<0.001	1
AF (λ=635 nm) (nm ⁻¹ ·cm ⁻¹)	0.974	0	0.010	1
AF (λ=650 nm) (nm ⁻¹ ·cm ⁻¹)	0.792	0	0.064	0
AF (λ=700 nm) (nm ⁻¹ ·cm ⁻¹)	0.445	0	0.717	0
<i>R</i> (<i>r</i> =260 μm, λ=575 nm) (cm ⁻²)	<0.001	1	<0.001	1
<i>R</i> (<i>r</i> =260 μm, λ=600 nm) (cm ⁻²)	0.039	1	<0.001	1
<i>R</i> (<i>r</i> =520 μm, λ=575 nm) (cm ⁻²)	<0.001	1	<0.001	1
<i>R</i> (<i>r</i> =520 μm, λ=600 nm) (cm ⁻²)	0.003	1	<0.001	1
μ _a (λ=575 nm) (cm ⁻¹)	0.002	1	0.060	0
μ _a (λ=600 nm) (cm ⁻¹)	0.045	1	0.152	0
μ _s ' (λ=575 nm) (cm ⁻¹)	0.251	0	<0.001	1
μ _s ' (λ=600 nm) (cm ⁻¹)	0.245	0	0.014	1
<i>StO2</i>	0.002	1	0.288	0
<i>f_{Hb}</i> (g/L)	0.002	1	0.070	0

FIG. 22

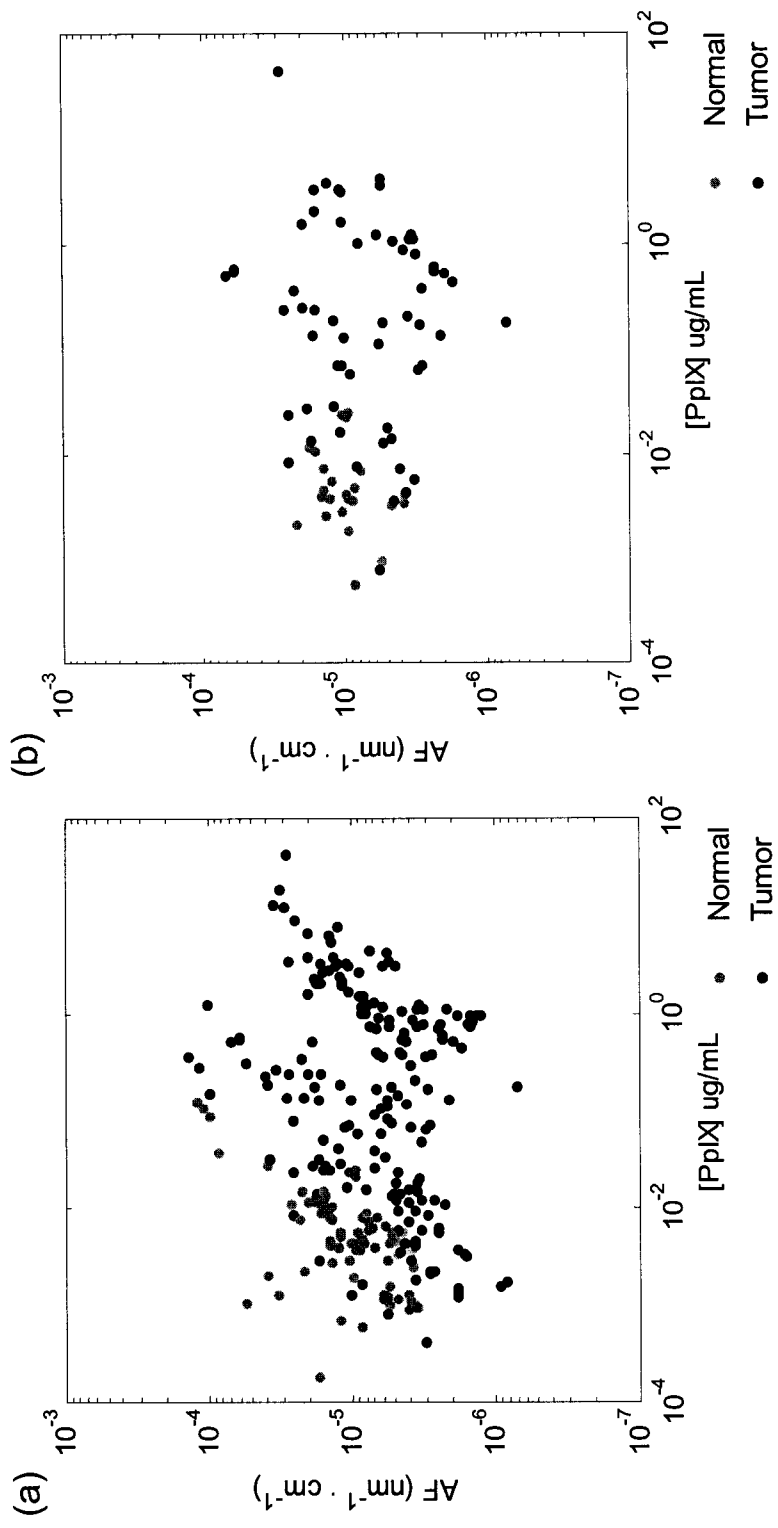

FIG. 23

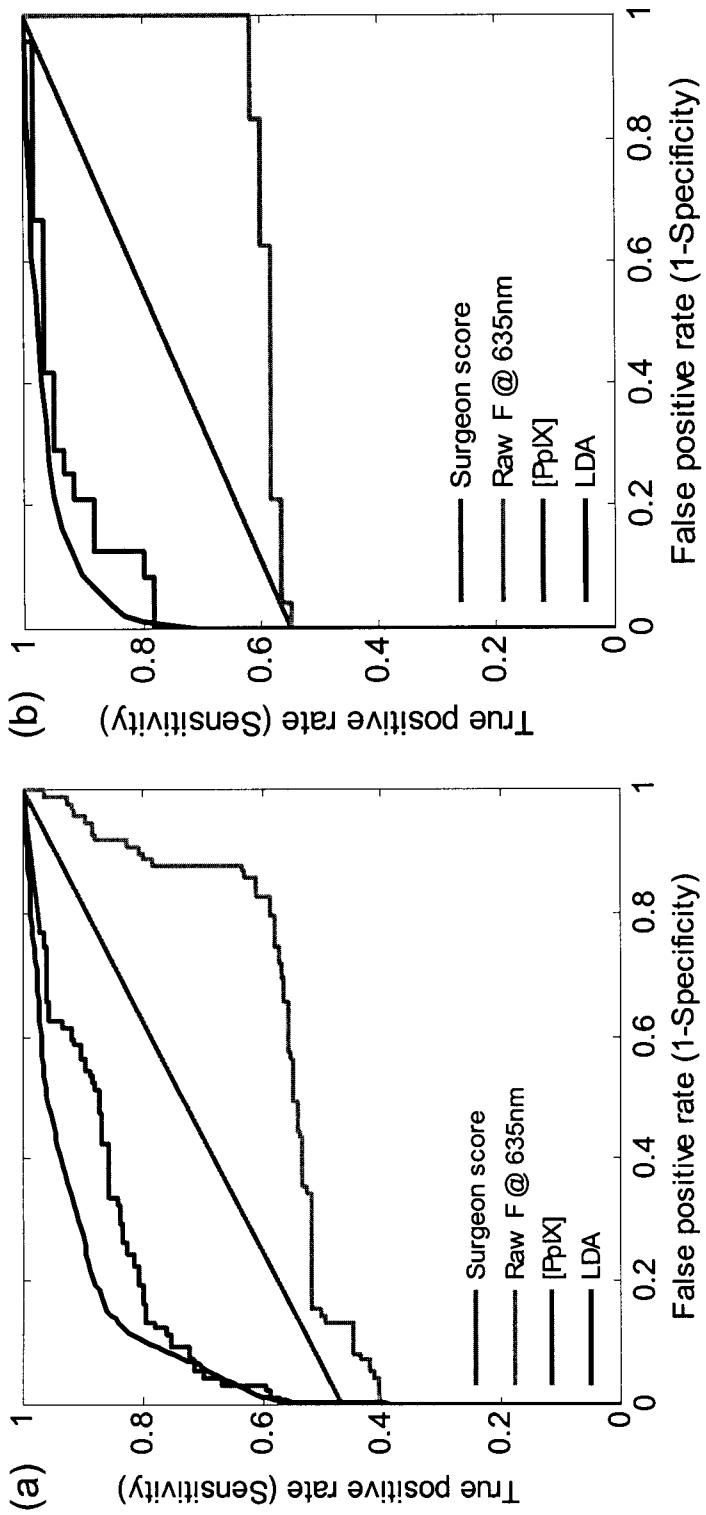

FIG. 24

	ROC a.u.c. (s.e.)	Sensitivity (%)	Specificity (%)
Surgeon's visible fluorescence score	0.734 (0.029)	58.6	78.0
Raw fluorescence spectroscopy @ 635 nm	0.571 (0.035)	51.6	84.8
[PpIX] ($\mu\text{g/mL}$)	0.880 (0.019)	79.7	86.9
Linear discriminant analysis	0.922 (0.022)	87.1	89.1

FIG. 25

	ROC a.u.c. (s.e.)	Sensitivity (%)	Specificity (%)
Surgeon's visible fluorescence score	0.775 (0.051)	62.6	83.1
Raw fluorescence spectroscopy @ 635 nm	0.577 (0.052)	55.0	98.3
[PpIX] ($\mu\text{g/mL}$)	0.945 (0.022)	88.3	93.3
Linear discriminant analysis	0.967 (0.016)	92.8	96.2

FIG. 26

	ROC a.u.c. (s.e.)	Sensitivity (%)	Specificity (%)
Surgeon's visible fluorescence score	0.542 (0.095)	50.2	54.3
Raw fluorescence spectroscopy @ 635 nm	0.247 (0.049)	22.2	73.3
[PpIX] ($\mu\text{g}/\text{mL}$)	0.651 (0.059)	47.2	93.3
Linear discriminant analysis	0.800 (0.068)	77.4	89.0

FIG. 27

	ROC a.u.c. (s.e.)	Sensitivity (%)	Specificity (%)
Surgeon's visible fluorescence score	0.750 (0.062)	60.0	80.0
Raw fluorescence spectroscopy @ 635 nm	0.664 (0.070)	66.7	95.8
[PpIX] ($\mu\text{g}/\text{mL}$)	0.984 (0.016)	91.7	95.8
Linear discriminant analysis	0.978 (0.050)	95.9	97.3

FIG. 28

	ROC a.u.c. (s.e.)	Sensitivity (%)	Specificity (%)
Surgeon's visible fluorescence score	0.800 (0.043)	65.5	86.2
Raw fluorescence spectroscopy @ 635 nm	0.694 (0.053)	58.3	100.0
[PpIX] ($\mu\text{g}/\text{mL}$)	0.898 (0.031)	78.3	87.2
Linear discriminant analysis	0.947 (0.057)	91.9	92.2

FIG. 29

INTERNATIONAL SEARCH REPORT

International application No.
PCT/CA2011/000090

<p>A. CLASSIFICATION OF SUBJECT MATTER IPC: G01N 21/64 (2006.01) , A61B 5/00 (2006.01) , A61K 41/00 (2006.01) , A61K 49/00 (2006.01) , G01N 21/55 (2006.01) , G01N 33/52 (2006.01) According to International Patent Classification (IPC) or to both national classification and IPC</p>		
<p>B. FIELDS SEARCHED</p>		
<p>Minimum documentation searched (classification system followed by classification symbols) IPC (2006.01): G01N, A61B, A61K</p>		
<p>Documentation searched other than minimum documentation to the extent that such documents are included in the fields searched</p>		
<p>Electronic database(s) consulted during the international search (name of database(s) and, where practicable, search terms used) TotalPatent, Canadian Patent Database, and keywords: distance, broadband, fluorescence, tissue</p>		
<p>C. DOCUMENTS CONSIDERED TO BE RELEVANT</p>		
Category*	Citation of document, with indication, where appropriate, of the relevant passages	Relevant to claim No.
X	US 7 613 504 B2 (Rowe) 3 November 2009 (03-11-2009) * entire document *	1-54
A	US 6 175 759 B1 (Chan et al.) 16 January 2001 (16-01-2001) * entire document *	1-54
<p><input type="checkbox"/> Further documents are listed in the continuation of Box C. <input checked="" type="checkbox"/> See patent family annex.</p>		
*	Special categories of cited documents :	“T” later document published after the international filing date or priority date and not in conflict with the application but cited to understand the principle or theory underlying the invention
“A”	document defining the general state of the art which is not considered to be of particular relevance	“X” document of particular relevance; the claimed invention cannot be considered novel or cannot be considered to involve an inventive step when the document is taken alone
“E”	earlier application or patent but published on or after the international filing date	“Y” document of particular relevance; the claimed invention cannot be considered to involve an inventive step when the document is combined with one or more other such documents, such combination being obvious to a person skilled in the art
“L”	document which may throw doubts on priority claim(s) or which is cited to establish the publication date of another citation or other special reason (as specified)	“&” document member of the same patent family
“O”	document referring to an oral disclosure, use, exhibition or other means	
“P”	document published prior to the international filing date but later than the priority date claimed	
Date of the actual completion of the international search		Date of mailing of the international search report
28 March 2011 (28-03-2011)		11 April 2011 (11-04-2011)
Name and mailing address of the ISA/CA Canadian Intellectual Property Office Place du Portage I, C114 - 1st Floor, Box PCT 50 Victoria Street Gatineau, Quebec K1A 0C9 Facsimile No.: 001-819-953-2476		Authorized officer Tsz Yeung Lam (819) 994-1651

INTERNATIONAL SEARCH REPORT
Information on patent family members

International application No.
PCT/CA2011/000090

Patent Document Cited in Search Report	Publication Date	Patent Family Member(s)	Publication Date
US7613504B2	03 November 2009 (03-11-2009)	AT434973T	15 July 2009 (15-07-2009)
		AU2002251767B2	13 September 2007 (13-09-2007)
		CA2448761A1	12 December 2002 (12-12-2002)
		CN1516564A	28 July 2004 (28-07-2004)
		CN100415164C	03 September 2008 (03-09-2008)
		DE60232794D1	13 August 2009 (13-08-2009)
		EP1397667A2	17 March 2004 (17-03-2004)
		EP1397667B1	01 July 2009 (01-07-2009)
		IL159108D0	12 May 2004 (12-05-2004)
		JP2005500095T	06 January 2005 (06-01-2005)
		JP2008296051A	11 December 2008 (11-12-2008)
		JP2008296052A	11 December 2008 (11-12-2008)
		KR20090012362A	03 February 2009 (03-02-2009)
		US2003078504A1	24 April 2003 (24-04-2003)
		US2002183624A1	05 December 2002 (05-12-2002)
		US7890158B2	15 February 2011 (15-02-2011)
		US2008297788A1	04 December 2008 (04-12-2008)
		US2008304712A1	11 December 2008 (11-12-2008)
		WO02099393A2	12 December 2002 (12-12-2002)
		WO02099393A3	27 February 2003 (27-02-2003)
US6175759B1	16 January 2001 (16-01-2001)	None	

专利名称(译)	用于量化荧光和光学性质的装置，系统和方法		
公开(公告)号	EP2529202A1	公开(公告)日	2012-12-05
申请号	EP2011734301	申请日	2011-01-25
[标]申请(专利权)人(译)	大学健康网络		
申请(专利权)人(译)	大学健康网络		
当前申请(专利权)人(译)	大学健康网络		
[标]发明人	KIM ANTHONY TAYWON WILSON BRIAN CAMPBELL		
发明人	KIM, ANTHONY TAYWON WILSON, BRIAN CAMPBELL		
IPC分类号	G01N21/64 A61B5/00 A61K41/00 A61K49/00 G01N21/55 G01N33/52		
CPC分类号	A61B1/043 A61B1/0638 A61B5/0059 A61B5/0071 A61B5/0084 G01N21/4738 G01N21/6428		
代理机构(译)	利明，约翰·杰勒德		
优先权	61/297969 2010-01-25 US		
其他公开文献	EP2529202A4		
外部链接	Espacenet		

摘要(译)

用于量化诸如组织的混浊介质中的荧光和光学性质的方法。还公开了适用于该方法的装置和系统。