



(12) **EUROPEAN PATENT APPLICATION**

(43) Date of publication:
02.07.2008 Bulletin 2008/27

(51) Int Cl.:
A61B 5/05 (2006.01) **A61M 1/16 (2006.01)**
A61B 5/053 (2006.01)

(21) Application number: **07024513.9**

(22) Date of filing: **13.08.2001**

(84) Designated Contracting States:
DE FR GB IT SE

• **Levin, Nathan**
New York
NY 10128 (US)

(30) Priority: **14.08.2000 US 638657**

(74) Representative: **Luderschmidt, Schüler & Partner**
Patentanwälte
John-F.-Kennedy-Strasse 4
65189 Wiesbaden (DE)

(62) Document number(s) of the earlier application(s) in accordance with Art. 76 EPC:
05027173.3 / 1 645 227
01963952.5 / 1 309 273

(71) Applicant: **RENAL RESEARCH INSTITUTE**
New York NY 10128 (US)

Remarks:

This application was filed on 18-12-2007 as a divisional application to the application mentioned under INID code 62.

(72) Inventors:
 • **Zhu, Fansan**
Flushing
NY 11355 (US)

(54) **Device and method for segmental bioimpedance measurements of a dialysis patient**

(57) The present invention includes a method of determining the dry body weight of a patient undergoing dialysis by means of segmental bioimpedance analysis. In preferred embodiments, dry body weight is determined

by comparison to the bioimpedance values of normal subjects or by monitoring changes in bioimpedance during dialysis. One embodiment of the present invention is a device for determining dry body weight during dialysis.

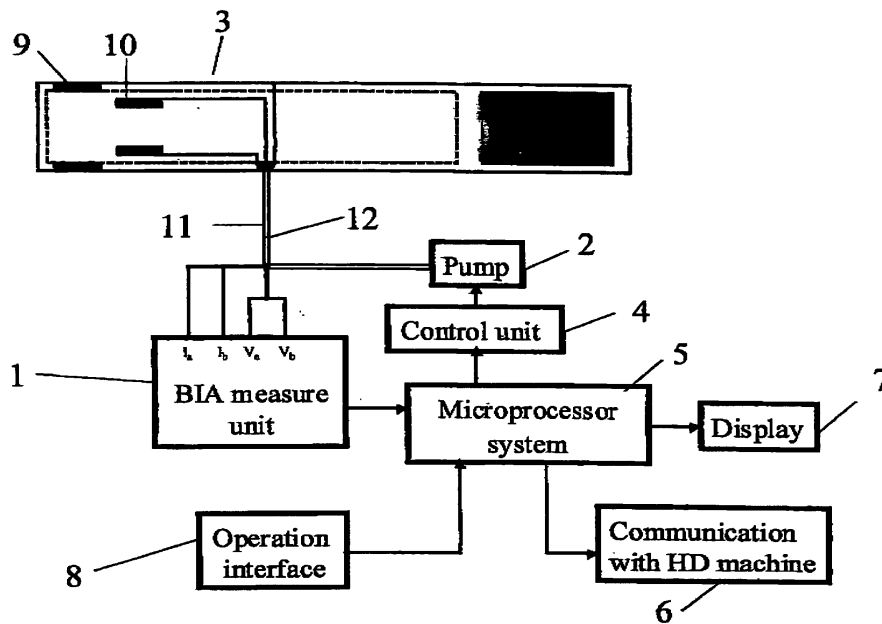

Fig.2

Description

[0001] Abstract, The present invention provides

a device for calculating cardiac output through bioimpedance measurements of a patient comprising:

5 a bioimpedance measurement unit;

a first electrical output means being in electrical communication with the bioimpedance analysis measurement unit and being attachable to an arm segment, the first electrical output means being adapted to apply electrical current to the arm segment;

10 a second electrical output means being in electrical communication with the bioimpedance analysis measurement unit and being attachable to a leg segment, the second electrical output means being adapted to apply electrical current to the leg segment;

a first electrical input means being in electrical communication with the bioimpedance analysis measurement unit and being attachable to an arm segment, the electrical input means being adapted to receive the current transmitted through the arm segment and transmit the same to the bioimpedance analysis measurement unit;

15 a second electrical input means being in electrical communication with the bioimpedance analysis measurement unit and being attachable to a leg segment, the electrical input means being adapted to receive the current transmitted through the leg segment and transmit the same to the bioimpedance analysis measurement unit;

a first pressure applying means for applying a maximum pressure to the arm segment, the first pressure applying means being in electrical communication with the bioimpedance analysis measurement unit;

20 a second pressure applying means for applying a maximum pressure to the leg segment, the second pressure applying means being in electrical communication with the bioimpedance analysis measurement unit; and

a means for selectively electronically connecting the bioimpedance analysis measurement unit between the first electrical input and output means and the second electrical input and output means;

25 wherein the bioimpedance analysis measurement unit is adapted to selectively measure stroke volume in the arm and leg segments by bioimpedance analysis.

Field of the Invention

[0002] The present invention relates to a device and method that utilize segmental bioimpedance for calculating cardiac output in individuals.

[0003] Bioelectrical impedance analysis (BIA) has been recognized as a noninvasive and simple technique to measure body hydration and hydration status (i.e. over-, under- or normal hydration) of subjects for more than twenty years. There is substantial literature on using BIA for the study of dry weight. Kouw *et al* proposed a method to measure changes in regional conductivity, and then to measure regional extracellular volume (ECV) and intracellular volume (ICV) by BIA.

35 See, P.M. Kouw, et al, Assessment of post-dialysis dry weight: an application of the conductivity measurement method. *Kidney Int.* 41:440-444, 1992. However, Kouw's method cannot be used to measure interstitial fluid alone as it does not distinguish between interstitial fluid and plasma, both of which make up the ECV compartment. Piccoli published a method of BIA vector analysis which uses the ratio of resistance to reactance to identify dry weight. While this technique could be used to compare the subjects' body hydration, it is unable to predict individual patient's dry weight because of the significant variation in measured values. See, Piccoli A: *Identification of operational clues to dry weight prescription in hemodialysis using bioimpedance vector analysis.* *Kidney Int.* 5 3:1036-1043, 1998.

[0004] To date, a major problem has been how to measure resistivity of blood and tissue separately, in order to estimate the fluid volume in the intravascular compartment and the interstitial compartment, respectively.

45 Furthermore, there is lacking an easy-operatable device for measuring the heart rate of a patient and the cardiac output of a patient using BIA.

Thus it is an object of the present invention to provide a device for calculating the heart rate and the cardiac output of a patient.

[0005] The present invention also provides a method of monitoring the heart rate of a hemodialysis patient comprising the steps of determining a time interval between two successive bioimpedance wave peaks and multiplying the reciprocal of the time interval by 60 to obtain the heart rate, and a method of calculating the cardiac output of a patient in need thereof comprising the steps of measuring the stroke volume in an arm segment by bioimpedance analysis, substantially simultaneously measuring the stroke volume in an ipsilateral leg segment by bioimpedance analysis, summing the stroke volume in the arm segment and the stroke volume in the leg segment, and multiplying the sum by twice the heart rate to obtain the cardiac output. Preferably, the stroke volume of the arm segment is calculated by applying an external maximum pressure to the arm segment and determining the change in blood volume in the arm segment between the point of maximum pressure and the point at which no external pressure is applied divided by the number of heart beats between the two points in time, and the stroke volume of the leg is calculated by applying an external maximum pressure to the leg segment and determining the change in blood volume in the leg segment between the point of maximum

pressure and the point at which no external pressure is applied divided by the number of heart beats between two points in time.

[0006] The present invention includes a device for calculating cardiac output through bioimpedance measurements of a patient comprising a bioimpedance measurement unit, a first electrical output means being in electrical communication with the bioimpedance analysis measurement unit and being attachable to an arm segment, the first electrical output means being adapted to apply electrical current to the arm segment, a second electrical output means being in electrical communication with the bioimpedance analysis measurement unit and being attachable to a leg segment, the second electrical output means being adapted to apply electrical current to the leg segment, a first electrical input means being in electrical communication with the bioimpedance analysis measurement unit and being attachable to an arm segment, the electrical input means being adapted to receive the current transmitted through the arm segment and transmit the same to the bioimpedance analysis measurement unit, a second electrical input means being in electrical communication with the bioimpedance analysis measurement unit and being attachable to a leg segment, the electrical input means being adapted to receive the current transmitted through the leg segment and transmit the same to the bioimpedance analysis measurement unit, a first pressure applying means for applying a maximum pressure to the arm segment, the first pressure applying means being in electrical communication with the bioimpedance analysis measurement unit, a second pressure applying means for applying a maximum pressure to the leg segment, the second pressure applying means being in electrical communication with the bioimpedance analysis measurement unit, a means for selectively electronically connecting the bioimpedance analysis measurement unit between the first electrical input and output means and the second electrical input and output means, and wherein the bioimpedance analysis measurement unit is adapted to selectively measure stroke volume in the arm and leg segments by bioimpedance analysis.

[0007] Other objects, features and advantages of the invention will be readily apparent from the following detailed description of a preferred embodiment thereof taken in conjunction with the drawings.

Brief Description of the Figures

[0008]

Figure 1A and 1B each represent a stylized 3-dimensional view of a body segment, that illustrates the principle of measuring resistivity according to one embodiment of the present invention. Figure 1A represents the situation in which no external pressure is applied to the segment and the blood vessels are uncompressed. Figure 1B illustrates the situation in which external pressure is applied to the segment and the blood vessels are compressed.

Figure 2 is a block diagram of a measurement system according to the present invention.

Figure 3 is a graph showing the change in body segment impedance in relation to the change in body segment blood volume due to arterial pulses.

Figure 4 is a graph showing changes in impedance of a limb segment in relationship to pressure cuff pressure.

Figure 5 is a diagram of a pressure cuff for measurement of the circumference of a body segment and for use in measurement of segmental bioimpedance when the body segment is compressed or uncompressed. Shown is a front view with the covering partially cut away, and in Figure 5A, a partial back view showing the conductive plates.

Figure 6 is a block diagram of a device according to the present invention that also provides a means for determining cardiac output.

Detailed Description of the Invention

[0009] The present invention provides a device for determining and monitoring various physiologic parameters of a patient, including but not limited to heart rate (HR) and cardiac output (CO).

[0010] One preferred embodiment of the present invention comprises a means to measure the resistivity of a body segment. The body segment may be the whole body, preferably a limb segment, more preferably a leg or arm segment, and most preferably a thigh segment. As shown in Figure 1A, the resistivity of a body segment is measured by the placement of measurement electrodes at points L1 and L2, separated by a distance L. One of skill in the art will appreciate that while distance L may vary, it is preferably about 10 cm. The resistivity between L1 and L2 is denoted as R. Also shown in Figure 1A is a cross-section of the body segment with the interstitial compartment denoted as T and blood vessels denoted as B. Optionally, a means to compress the body segment is provided, for example a pressure cuff 3 that surrounds the body segment. When the body segment is not compressed, for example when the pressure cuff 3

is uninflated, the blood vessels are uncompressed and the resistivity R reflects the resistivity of both the interstitial compartment T and the intravascular compartment B . As shown in Figure 1B, when the body segment is compressed, for example by inflating the pressure cuff, to a pressure above about the systolic blood pressure, optionally up to about 240 mmHg, the blood vessels are compressed and substantially all of the blood volume contained within the intravascular compartment of the body segment is forced out of the body segment. When the resistivity between the electrodes placed at $L1$ and $L2$ is measured under such circumstances, the resistivity value ρ_T represents the resistivity of the interstitial compartment of the body segment.

[0011] The principle of measurement of segmental bioimpedance provides a means to measure segmental resistivity and may be explained with reference to Figures 1A and 1B. Segmental resistivity is calculated using the formula:

[0012] Where ρ_{measure} is the measured segmental resistivity; A is the cross-sectional area of the segment ($A = C^2/4\pi$, where C is the circumference of the segment). When no pressure is applied to the body segment the cross sectional area A_0 represents the cross sectional area of the body segment including that of the blood vessels, when pressure of at least systolic blood pressure is applied the cross sectional area A_p is that of the body segment minus the cross sectional area of the blood vessels; R is resistance as measured by bioimpedance analysis; and L is the distance between the measurement points (i.e. the distance between measurement electrodes).

The measured resistivity of the body segment depends on a number of factors including the frequency of the injected current and the body mass index (BMI). Preferably a single frequency, optionally multiple frequencies (multi-frequencies) are used. Injected frequencies from about 1 kHz to about 1000 kHz, more preferably from about 1 kHz to about 50 kHz, most preferably from about 1 kHz to about 10 kHz are utilized. BMI reflects fat content, and is defined as the body weight in kg divided by the square of the height in meters (weight/height²) and is typically measured in kg/m². In order to distinguish between intravascular and interstitial fluid, preferably the body segment is compressed, optionally by a pressure cuff, preferably a blood pressure cuff (BP cuff) to produce a pressure (P) sufficient to squeeze blood volume out of the studied segment over a few seconds. Thus, two resistivity values can be measured: ρ_0 (uncompressed body segment, $P = 0$ mmHg) and ρ_p (body segment is compressed to a pressure from about systolic blood pressure up to $P_{\text{max}} = 240$ mmHg).

The measurement system comprises a high speed, low noise, acquisition and multi-frequency bioimpedance measurement unit, such as is known to one of ordinary skill in the art, preferably a Xitron 4200s (Xitron Technologies, San Diego, CA). Connected to the bioimpedance measurement unit, the system includes an electrical output means attachable to a body segment, the electrical output means preferably comprising at least two injector electrodes for application to a body segment and for the injection of current into the body segment. The system can apply a single frequency of current, or optionally multiple frequencies of electricity (multi-frequencies) ranging from about 1 kHz to about 1000 kHz, more preferably from about 1 kHz to about 50 kHz, most preferably a single frequency from about 1 kHz to about 10 kHz through the injector electrodes. The system further comprises an electrical input means that is adapted to receive the electrical current transmitted from the output means and through the body segment and to then transmit the current to the bioimpedance analysis measurement unit. The input means comprises at least two measurement electrodes for application to the body segment for the receiving and transmission, to the BIA measurement unit, of current transmitted through the selected segment. The electrodes may be made of Ag/AgCl film, conductive rubber, or other appropriate materials which are readily apparent to one of ordinary skill in the art. The injector and measurement electrodes are connected electrically to the BIA measurement unit. This electrical connection may be accomplished by a number of means readily apparent to a person of ordinary skill in the art, but preferably by electrical cables.

[0013] In one preferred embodiment of the present invention, the electrodes are incorporated into a pressure cuff suitable for surrounding and compressing the body segment. A single cable optionally may incorporate both the electrical wires to the injector and measurement electrodes and the air tubing connected to the pressure cuff. Such a cable is used to connect the pressure cuff to the measuring unit and an optional air pump. Alternatively, separate electrical cables and a separate air hose may be employed. Optionally, the pressure cuff incorporates a means for electrically measuring the circumference of the body segment. An example of a preferred pressure cuff configuration 3, which is not intended to be limiting in any way is disclosed in Figure 5. The pressure cuff 3 is a blood-pressure cuff type device that comprises a substantially rectangular form suitable for wrapping around a body segment, such that the body segment is encircled by the device. The pressure cuff is composed of a fabric or other flexible material that preferably is capable of being easily cleaned and/or decontaminated. Material that is suitable will be readily apparent to one of ordinary skill in the art. The pressure cuff also includes a means for securing the device on the body segment, such as a Velcro[®] system or other such securing system 26, as will be readily apparent to one of ordinary skill in the art. Contained within the pressure cuff 3 is a flexible air-bladder 25 or similar means of compressing the body segment, and applying substantially circumferential pressure of at least about systolic blood pressure to the body segment. The air-bladder is connected to an air hose through which air can be moved to inflate or deflate the air-bladder. The pressure cuff preferably includes at least two injector electrodes 9 and at least two measurement electrodes 10 incorporated therein. The injector and measurement electrodes are electrically connected, preferably by electrical wires 20 and 21 respectively, to a cable connector 27, or other means of electrically connecting the pressure cuff 3 to a bioimpedance measurement unit. At least one, preferably

two conductive bands 24 extend substantially the length of the pressure cuff, such that the length of the bands is at least equal to the smallest normal body segment circumference. The bands are composed of a material of stable resistivity. Suitable material includes Cu-Sc alloy or conductive rubber. Other suitable material will be readily apparent to one of ordinary skill in the art. The pressure cuff also comprises at least one and preferably two conductive plates 28 located at the end of the pressure cuff opposite to the end with the securing means 26. The conductive bands 24 and conductive plates 28 are electrically isolated from one another and each is connected, preferably by wires 22 and 23, respectively, to a means of measuring resistivity. The band(s) 24 and plate(s) 28 are arranged on the pressure cuff, such that when the pressure cuff is wrapped around the body segment, the plate(s) 28 electrically connects with the band(s) 24 at a location or locations along the length of the belt such that the distance, measured along the length of the pressure cuff, from the plate(s) 28 to the point of contact on the band(s) 24 is substantially equal to the circumference of the body segment. The circumference of the body segment then can be determined electrically according to the equation:

Where L_{b1} is the length of the band between the end of the pressure cuff 3 closest to the end where the plate(s) is (are) located and the location at which the plate 28 contacts the band 24;

where R1 is the resistivity of the band between its end closest to the end at which the plate(s) is (are) located and the location at which the plate 28 contacts the band;

where A1 is the cross-sectional area of the band;

and ρl is the resistivity of this material.

[0014] In this manner, by determining the resistivity of the length of the band(s) that substantially equals the circumference of the body segment, the circumference of the body segment can be determined electrically. In this embodiment, it is preferred that the pressure cuff be securely applied prior to each measurement in order to more accurately measure body segment circumference.

[0015] Another embodiment comprises a device for controlling a hemodialysis machine. In this and in other embodiments disclosed herein, an example of a hemodialysis machine suitable for use in or with the invention is that disclosed in U.S. Patent No. 5,580,460 to Polaschegg. An example, which is not intended to be limiting in any way, is depicted in Figure 2. In addition to the BIA measurement unit 1, the measurement system also comprises one or more of an air pump 2 to produce pressure to inflate the pressure cuff 3, a control unit 4 to transfer signals from the microprocessor in order to operate the pump, a microprocessor system 5 which is at least a minimal computer with fast data transfer, rapid access and a memory space sufficiently large to permit the manipulation and analysis of the inputted data, a means of communicating with the dialysis machine 6 whereby control signals are sent to and received from the dialysis machine optionally allowing the control of ultrafiltration rate and other hemodialysis parameters according to body hydration status, a display 7 that shows the result of online measurement and an operation interface 8 to input individual patients' parameters to monitor and control dry weight and optionally a means of communication to a standard personal computer (PC) or other device. Optionally, data including, but not limited to, resistance, resistivity, cuff pressure and heart rate is transmitted to the PC by a RS 232 interface or another standard interface in ASCII or other format such that the waveforms of resistivity, pressure values, heart rates and other parameters can be observed, stored, or manipulated on the PC. The block diagram in Figure 2 shows injector electrodes 9 and measurement electrodes 10, optionally incorporated into the pressure cuff 3. The injector and measurement electrodes are attached, preferably by electrical wiring 11, to the output sockets I_a and I_b and input (measurement) sockets V_a and V_b of the BIA measurement unit 1, and the air pump 2 is connected to the pressure cuff by an air hose 12.

[0016] In this embodiment, various patient specific parameters are input into the microprocessor system 5 by means of the operation interface 8. Inputted data and other data optionally are displayed in the display 7. The microprocessor system 5 is connected to the BIA measurement unit 1 by a means of transmitting signals to the BIA measurement unit and signaling the BIA measurement unit to send electrical current to the injector electrodes 9. When such an electrical current is sent through the injector electrodes into the body segment, the current is detected by the measurement electrodes and transmitted back to the BIA measurement unit for processing, the derived data being transmitted to the microprocessor system. The microprocessor system is also connected to the pump control unit 4 which is capable of sending signals to the air pump 2 to inflate and deflate the pressure cuff 3, allowing bioimpedance measurements to be made with the pressure cuff inflated and/or deflated. The microprocessor system is also connected to the hemodialysis machine by a communication means 6, whereby signals can be sent to the hemodialysis machine permitting changes in the hemodialysis procedure, such that the patient's hydration status may be altered.

[0017] Bioimpedance is measured optionally with the body segment uncompressed or preferably, with the body segment compressed, preferably by inflation of the pressure cuff. The injection and measurement of current is coordinated to correspond with time points when the pressure cuff is substantially fully inflated or substantially deflated.

[0018] To measure resistivity, current is injected into the body segment through injector electrodes and the current transmitted through the body segment is received by the measurement electrodes and transmitted to the BIA measurement unit for calculation of the resistivity of the body segment, the derived data optionally being transmitted to the microprocessor system, which, in turn, according to the method disclosed herein.

[0019] It is known that the bioimpedance of a body segment changes as the blood pumped by the heart enters and leaves the body segment with each heart beat. By frequent or continuous injection of current and measurement of segmental bioimpedance, a wave form that reflects the pulse can be derived. Based on this information, the present invention provides a means to determine and monitor the heart rate of a patient prior to, during, or after hemodialysis by means of BIA, according to the equation:

$$HR = 60/(T_{i+1} - T_i)$$

where HR is the heart rate in beats per minute; and $T_{i+1} - T_i$ is the time period between peaks of any two successive heart beat induced impedance waves, T_i and T_{i+1} , as shown in Figure 3.

[0020] In another embodiment of the invention, BIA is optionally used to determine cardiac output in individuals, including, but not limited to healthy subjects, and dialysis patients prior to, during, or following dialysis, Estimation of CO is based on the assumption that there is a high degree of symmetry in the distribution of blood vessels on both sides of the body and the fact that total blood volume per pulse (stroke volume) can be measured in the segments of the arm (SV_{arm}) and leg (SV_{leg}) using bioimpedance simultaneously (preferably measuring the stroke volume from an arm and an ipsilateral leg (i.e., on the same side of the body)).

[0021] The equation used to calculate cardiac output is:

$$CO = 2 \times HR(k_3 \times SV_{arm} + k_4 \times SV_{leg}) \text{ (L/min)}$$

where SV_{arm} and SV_{leg} are the stroke volume in the arm and in the leg respectively;

SV_{arm} and SV_{leg} are calculated using the following formulas:

$$SV_{arm} = \Delta V_A / N_A \text{ and } SV_{leg} = \Delta V_L / N_L$$

where ΔV_A is the change in blood volume in the arm and ΔV_L is the change in the blood volume in the leg between the time point of maximal cuff pressure (shown as segment point A in Figure 4, during which time substantially all the blood volume is squeezed from the limb segment) and the time point when the pressure cuff is deflated (Shown as point B in Figure 4, during which time blood volume is refilled by the stroke volume). N_A and N_L are the number of pulses during changes in impedance from peak point (A) to baseline (B) respectively.

[0022] The values for ΔV_A and ΔV_L are calculated as follows:

$$\Delta V_A = \rho_b L^2 \Delta Z_A / Z_A^2 \text{ and } \Delta V_L = -\rho_b L^2 \Delta Z_L / Z_L^2 \quad \text{Equation 1}$$

where ρ_b is the resistivity of blood, L is the length of the body or limb segment between the electrodes, and Z_A and Z_L are each respective impedance values. Calculations of ΔV_A and ΔV_L are performed according to the method of J. G. Webster in, Medical Instrumentation Application and Design, 3rd Ed., Wiley, New York, 1998 pp. 357 - 362, which is hereby incorporated herein by reference, in its entirety.

[0023] The coefficients k_3 and k_4 are coefficients of calibration for individuals in ΔV_A and ΔV_L respectively. The calibration is performed by injecting from about 5 ml to about 150 ml into a vein distal to the arm segment in which resistivity

is to be measured, while the resistivity is measured continuously in the arm segment. As the wave of increased volume (ΔV) passes through the segment, there is a change in resistance (ΔR) in relation to the volume injected. Using the relationship between $\Delta V/\Delta R$, k_3 and k_4 are calibrated.

[0024] The calibrating process provides the information about how a change in resistance per ohm is related to a known change in volume ($\Delta V/\Delta R$). By definition, define $k_c = \Delta V/\Delta R$ as a calibration coefficient, where ΔV is the volume of injected saline (ml) and ΔR is the change in resistance in the calibrating segment, Thus, k_3 is defined by equation as follows:

$$k_3 = k_c \times \Delta Z_A / (N_A \times V_A)$$

[0025] Where ΔZ_A is the change in impedance in the arm, V_A is volume calculated by set, and N_A is number of pulses. Similarly, the equation $k_4 = k_c \times \Delta Z_L / (N_L \times V_L)$ is used to calibrate for changes in the volume of a leg.

[0026] One embodiment of a system such as that disclosed in Figure 2, but additionally being capable of measuring cardiac output is shown in Figure 6. Included are two sets of electrodes 9 and 10 and 9' and 10', preferably incorporated into two pressure cuffs 3 and 3' adapted to be attached to a leg segment (not shown) and to an ipsilateral arm segment (not shown), both sets of electrodes being connected to a digital switch, via wiring 11 and 11', capable of rapidly switching between each set of electrodes, so that measurements may be taken from either the leg segment or the arm segment substantially simultaneously. Preferably the digital switch 30 has the capacity to achieve a sampling frequency of at least about 200 Hz and, more preferably, greater than 1 kHz. Optionally, there is a means to send a control signal from a computer 31 to the digital switch so that the sample frequency can be changed as needed.

Claims

1. A method of calculating the cardiac output of a patient in need thereof comprising the steps of:

measuring the stroke volume in an arm segment by bioimpedance analysis:

substantially simultaneously measuring the stroke volume in an ipsilateral leg segment by bioimpedance analysis;

summing the stroke volume in the arm segment and the stroke volume in the leg segment; and multiplying the sum by twice the heart rate to obtain the cardiac output.

2. The method of claim 1, wherein stroke volume of the arm segment is calculated by applying an external maximum pressure to the arm segment and determining the change in blood volume in the arm segment between the point of maximum pressure and the point at which no external pressure is applied divided by the number of heart beats between the two points in time, and wherein the stroke volume of the leg is calculated by applying an external maximum pressure to the leg segment and determining the change in blood volume in the leg segment between the point of maximum pressure and the point at which no external pressure is applied divided by the number of heart beats between two points in time.

3. A device for calculating cardiac output through bioimpedance measurements of a patient comprising:

a bioimpedance measurement unit;

a first electrical output means being in electrical communication with the bioimpedance analysis measurement unit and being attachable to an arm segment, the first electrical output means being adapted to apply electrical current to the arm segment;

a second electrical output means being in electrical communication with the bioimpedance analysis measurement unit and being attachable to a leg segment, the second electrical output means being adapted to apply electrical current to the leg segment;

a first electrical input means being in electrical communication with the bioimpedance analysis measurement unit and being attachable to an arm segment, the electrical input means being adapted to receive the current transmitted through the arm segment and transmit the same to the bioimpedance analysis measurement unit;

a second electrical input means being in electrical communication with the bioimpedance analysis measurement unit and being attachable to a leg segment, the electrical input means being adapted to receive the current transmitted through the leg segment and transmit the same to the bioimpedance analysis measurement unit;

a first pressure applying means for applying a maximum pressure to the arm segment, the first pressure applying means being in electrical communication with the bioimpedance analysis measurement unit;
a second pressure applying means for applying a maximum pressure to the leg segment, the second pressure applying means being in electrical communication with the bioimpedance analysis measurement unit;
5 a means for selectively electronically connecting the bioimpedance analysis measurement unit between the first electrical input and output means and the second electrical input and output means;
a unit adapted to sum the stroke volume in the arm segment and the stroke volume in the leg segment and to multiply the sum by twice the heart rate to obtain the cardiac output;

10 wherein the bioimpedance analysis measurement unit is adapted to selectively measure stroke volume in the arm and leg segments by bioimpedance analysis.

4. A method for determining the hydration status of a dialysis patient comprising the steps of:

15 measuring the resistivity of a body segment of the patient;
correlating the measured resistivity with predetermined normal dry weight values; and
deriving the patient's hydration status,

5. A method for determining a hemodialysis patient's dry weight comprising the steps of:

20 periodically measuring the resistivity of a body segment during hemodialysis;
comparing successive resistivity measurements; and
identifying the patient's dry weight when a substantially constant resistivity is reached.

6. A method for dialyzing a patient to the patient's dry weight comprising the steps of:

25 measuring the resistivity of a body segment of the patient;
correlating the measured resistivity with predetermined normal dry weight values; deriving the patient's hydration;
and
30 continuing hemodialysis until the resistivity of the body segment correlates with the predetermined normal dry weight values.

7. A method for hemodialysing a patient to the patient's dry weight comprising the steps of:

35 periodically measuring the resistivity of a body segment during hemodialysis;
comparing successive resistivity measurements; and
discontinuing hemodialysis when a substantially constant resistivity is reflected.

8. A method of monitoring the heart rate of a hemodialysis patient comprising the steps of:

40 determining a time interval between two successive bioimpedance wave peaks; and
multiplying the reciprocal of the time interval by 60 to obtain the heart rate.

9. A method of calculating the cardiac output of a patient in need thereof comprising the steps of:

45 measuring the stroke volume in an arm segment by bioimpedance analysis:

substantially simultaneously measuring the stroke volume in an ipsilateral leg segment by bioimpedance analysis;

50 summing the stroke volume in the arm segment and the stroke volume in the leg segment; and
multiplying the sum by twice the heart rate to obtain the cardiac output.

10. A device for controlling a hemodialysis machine comprising:

55 a bioimpedance analysis measurement unit in electrical communication with a hemodialysis machine;
an electrical output means being in electrical communication with the bioimpedance analysis measurement unit and being attachable to a body segment, the electrical output means being adapted to apply electrical current to the body segment;

an electrical input means being in electrical communication with the bioimpedance analysis measurement unit and being attachable to a body segment, the electrical input means being adapted to receive the current transmitted through the body segment and transmit the same to the bioimpedance analysis measurement unit; and

5 wherein the bioimpedance analysis measurement unit is adapted to determine body segment resistivity based on the current transmitted through the body segment and wherein the bioimpedance analysis measurement unit provides feedback to the hemodialysis machine in response to the body segment resistivity.

11. The device of claim 10 further including means for applying pressure to the body segment, the pressure applying means being in electrical communication with the bioimpedance analysis measurement unit.

12. The device of claim 11 wherein the pressure applying means includes a pressure cuff, the pressure cuff being adapted to encircle the body segment.

13. The device of claim 12 wherein the electrical output means includes at least two injector electrodes, the electrical input means includes at least two measurement electrodes, and wherein the injector electrodes and the measurement electrodes are secured to the pressure cuff.

14. The device of claim 13 wherein the pressure cuff further includes at least one conductive band with opposing ends and at least one conductive plate positioned adjacent one of the ends of the conductive band, the conductive band extends substantially the length of the pressure cuff, the conductive plate is arranged to electrically contact the conductive band at a point along the length of the same wherein the distance between the conductive plate and the point of contact of the conductive band is substantially equal to the circumference of the body segment, and wherein the bioimpedance measurement unit is adapted to electrically determine body segment circumference based on the distance between the end of the band adjacent to the plate and the point of contact of the plate along the length of the band.

15. A device for calculating cardiac output through bioimpedance measurements of a patient comprising:

- 30 a bioimpedance measurement unit;
- a first electrical output means being in electrical communication with the bioimpedance analysis measurement unit and being attachable to an arm segment, the first electrical output means being adapted to apply electrical current to the arm segment;
- 35 a second electrical output means being in electrical communication with the bioimpedance analysis measurement unit and being attachable to a leg segment, the second electrical output means being adapted to apply electrical current to the leg segment;
- a first electrical input means being in electrical communication with the bioimpedance analysis measurement unit and being attachable to an arm segment, the electrical input means being adapted to receive the current transmitted through the arm segment and transmit the same to the bioimpedance analysis measurement unit;
- 40 a second electrical input means being in electrical communication with the bioimpedance analysis measurement unit and being attachable to a leg segment, the electrical input means being adapted to receive the current transmitted through the leg segment and transmit the same to the bioimpedance analysis measurement unit;
- a first pressure applying means for applying a maximum pressure to the arm segment, the first pressure applying means being in electrical communication with the bioimpedance analysis measurement unit;
- 45 a second pressure applying means for applying a maximum pressure to the leg segment, the second pressure applying means being in electrical communication with the bioimpedance analysis measurement unit; and
- a means for selectively electronically connecting the bioimpedance analysis measurement unit between the first electrical input and output means and the second electrical input and output means;

50 wherein the bioimpedance analysis measurement unit is adapted to selectively measure stroke volume in the arm and leg segments by bioimpedance analysis.

55

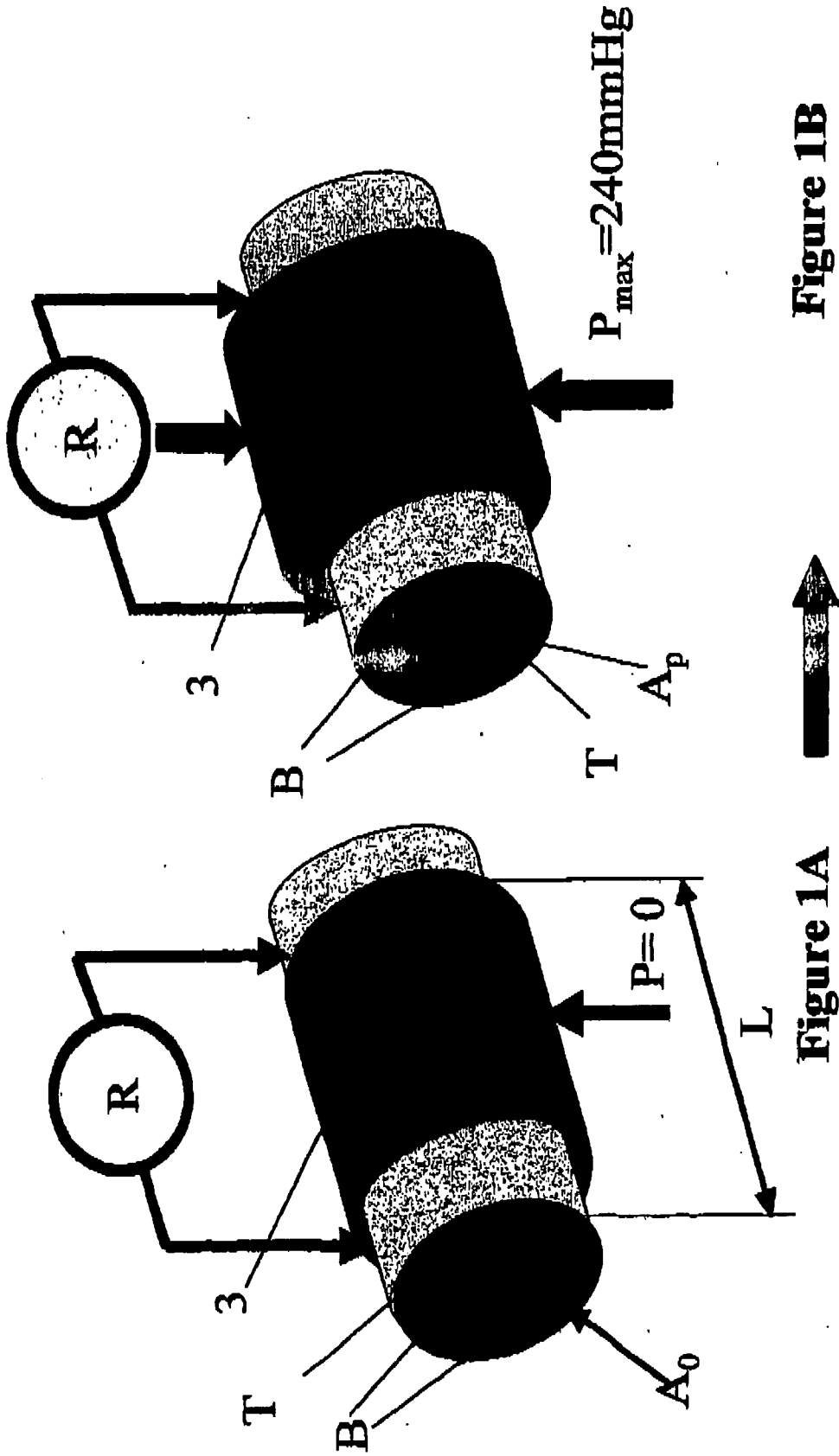

Figure 1B

Figure 1A

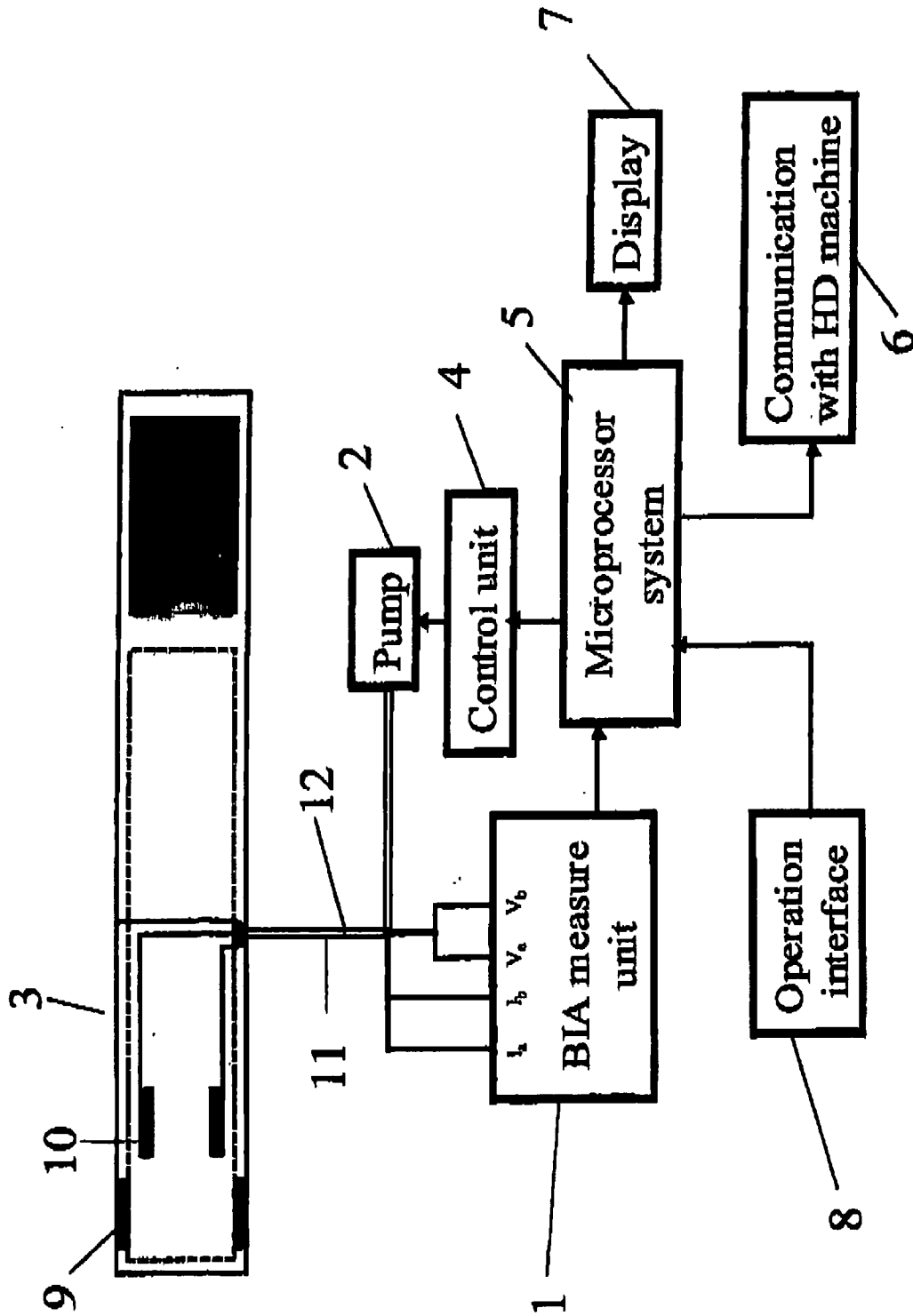

Fig.2

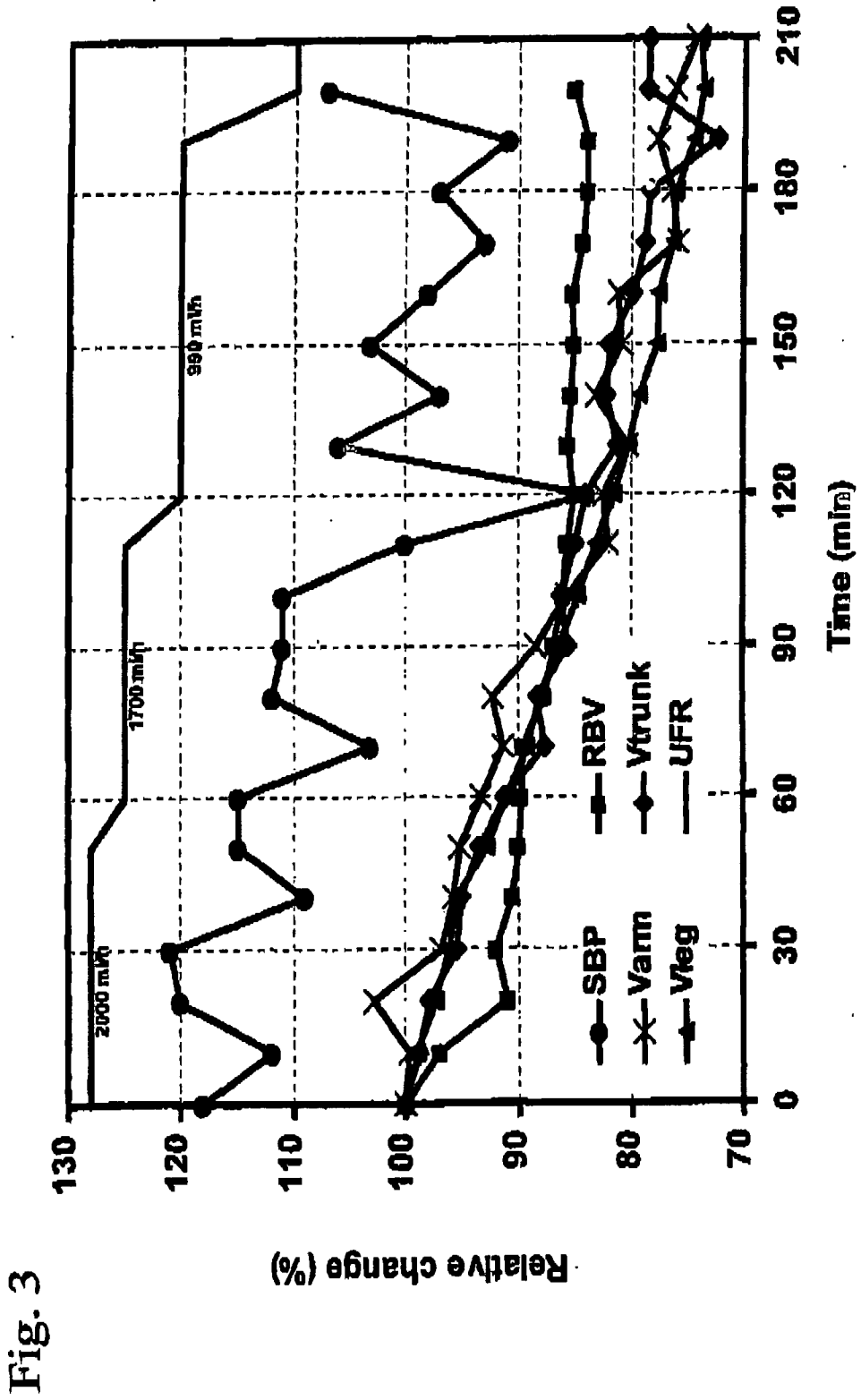
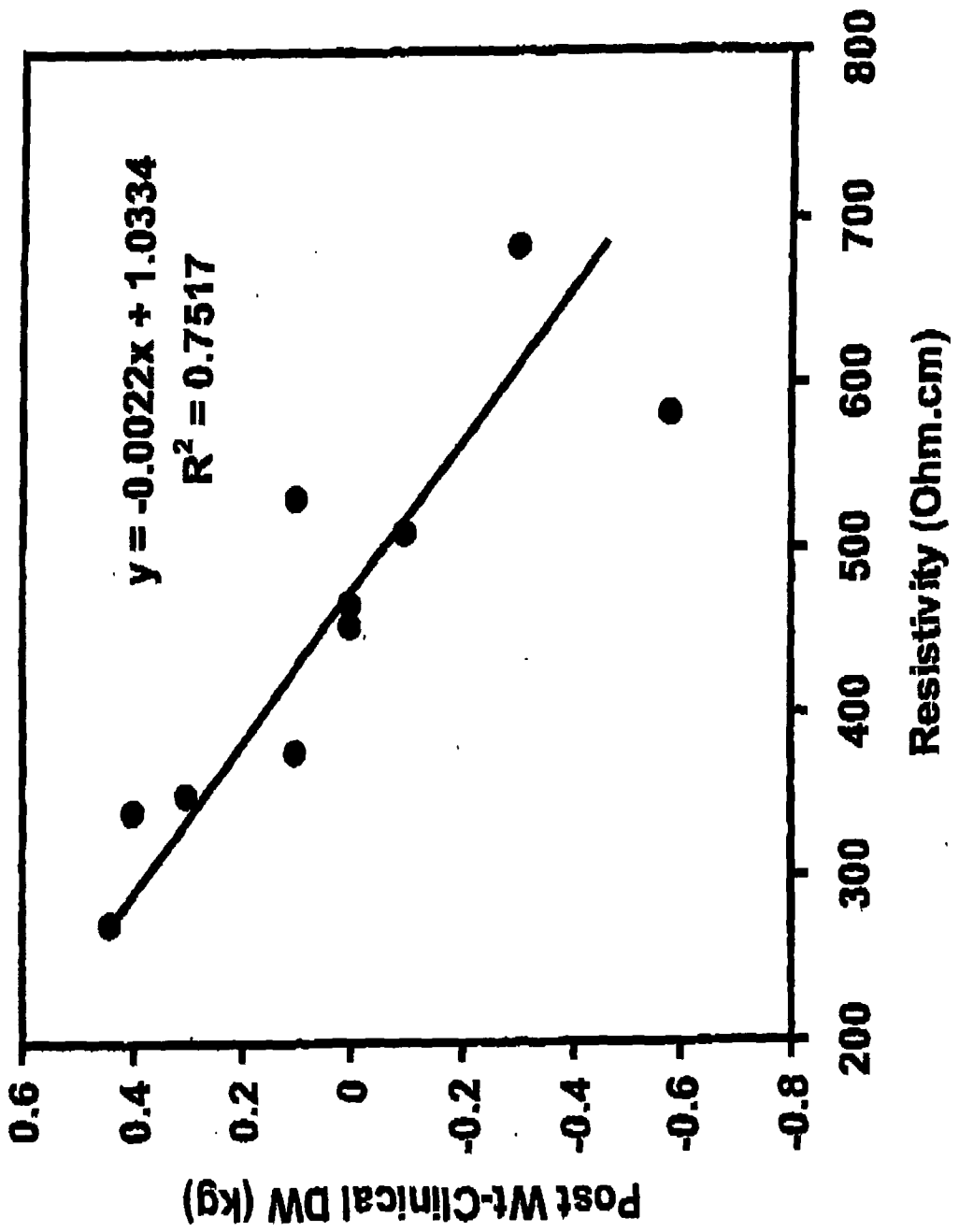

Fig. 4



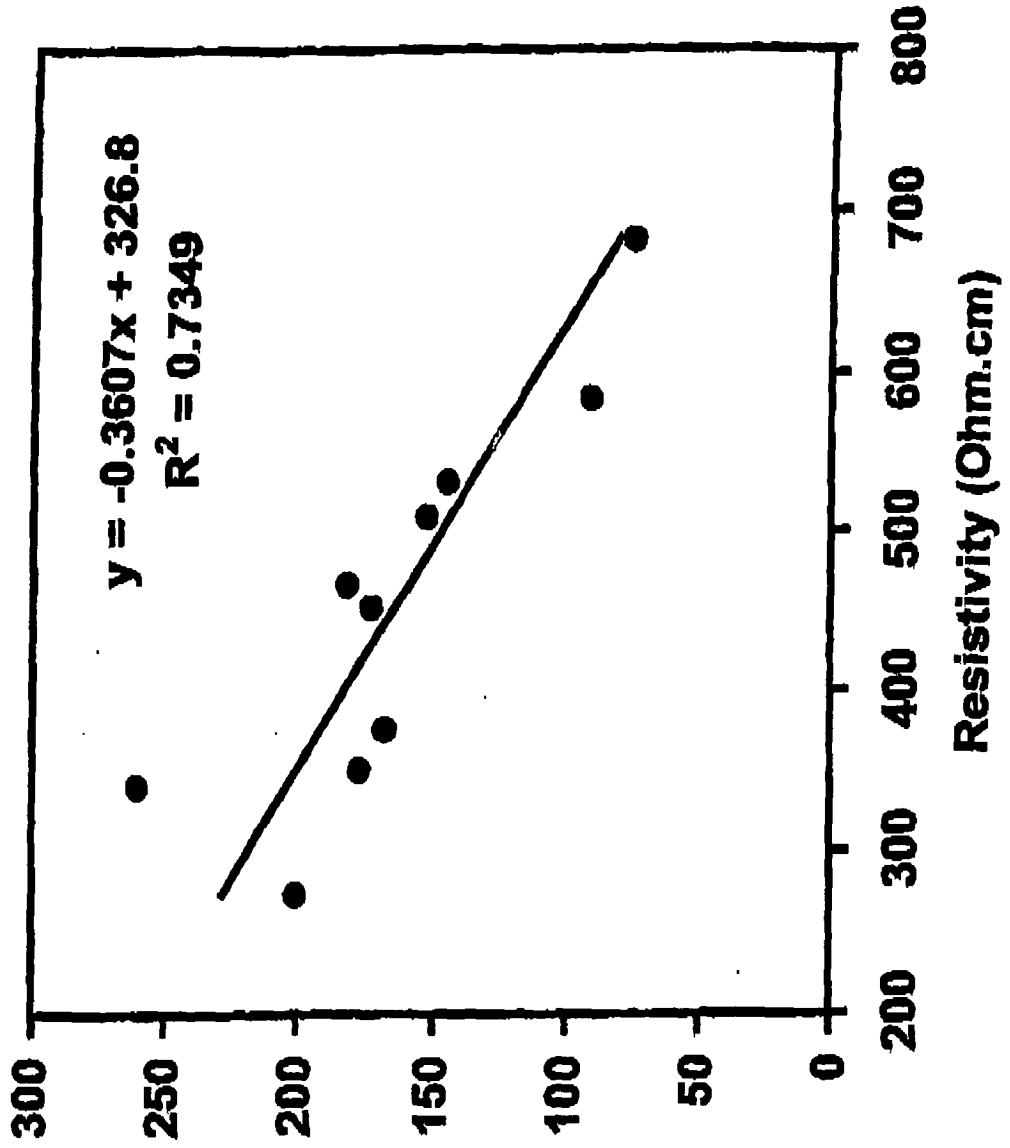

Fig.5 Blood Pressure at end HD (mmHg)

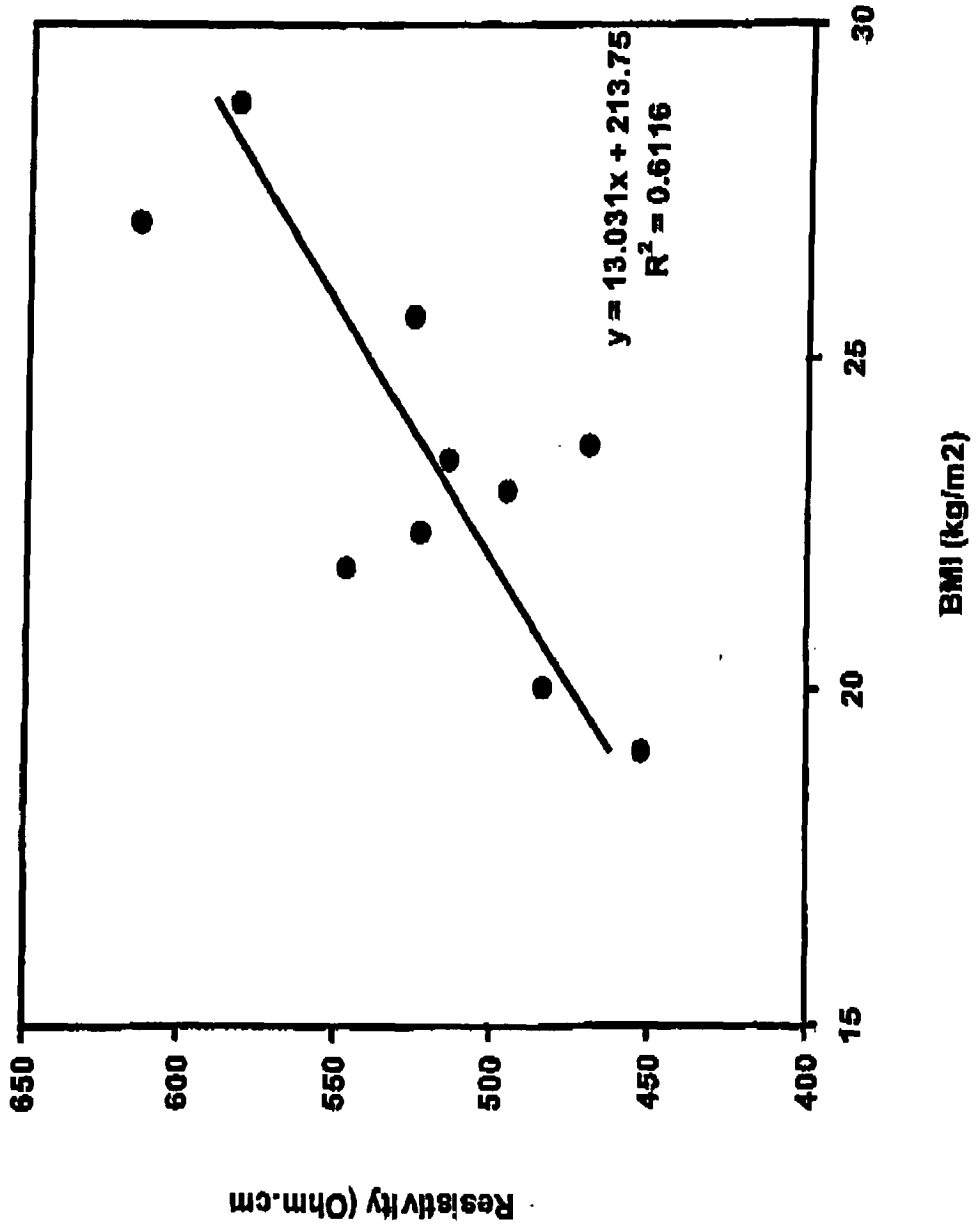

Fig. 6

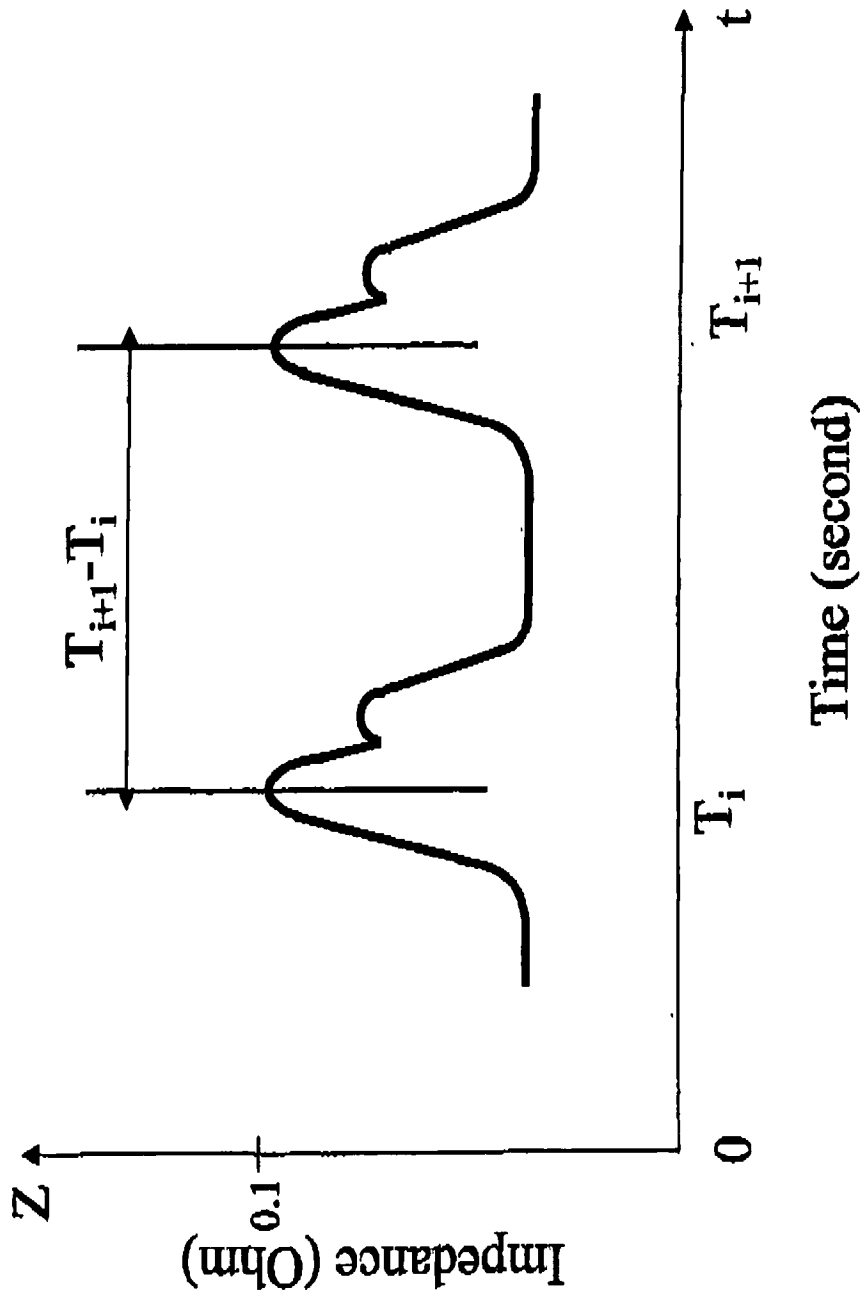

Fig. 7

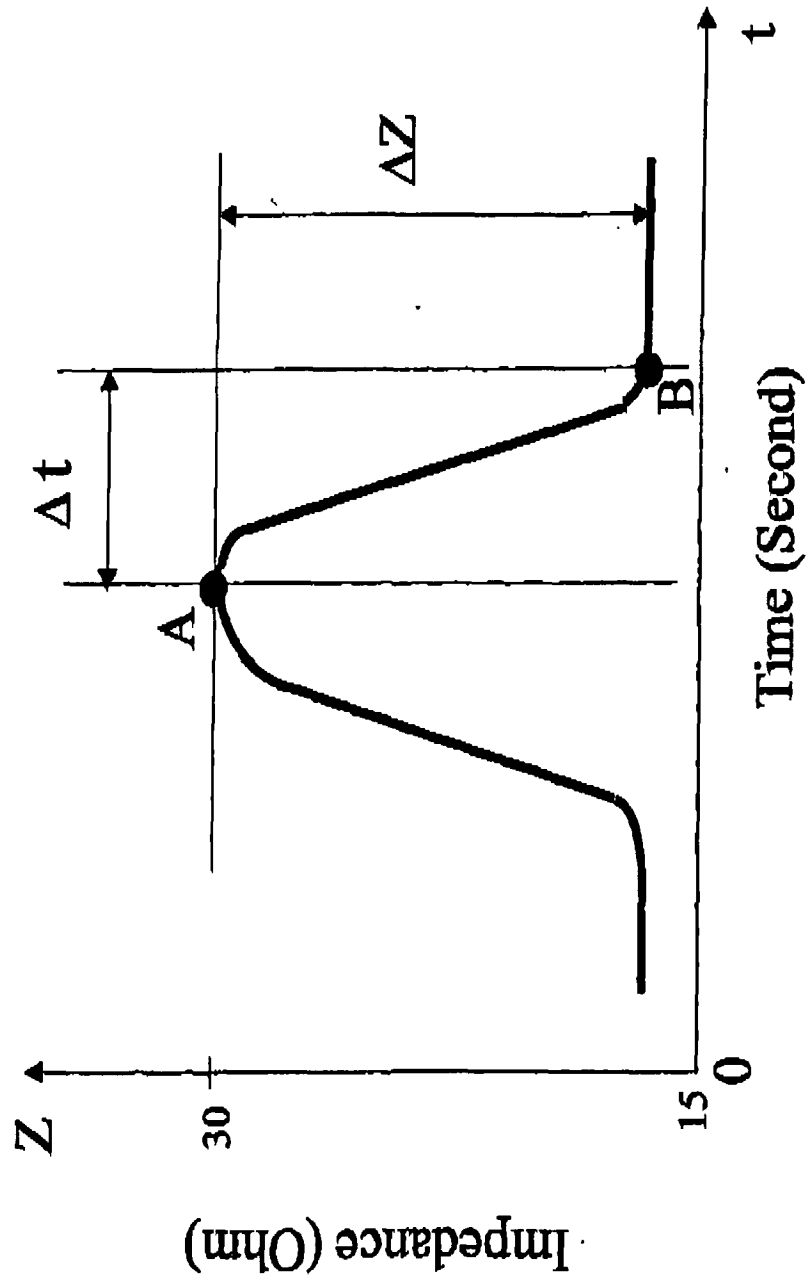
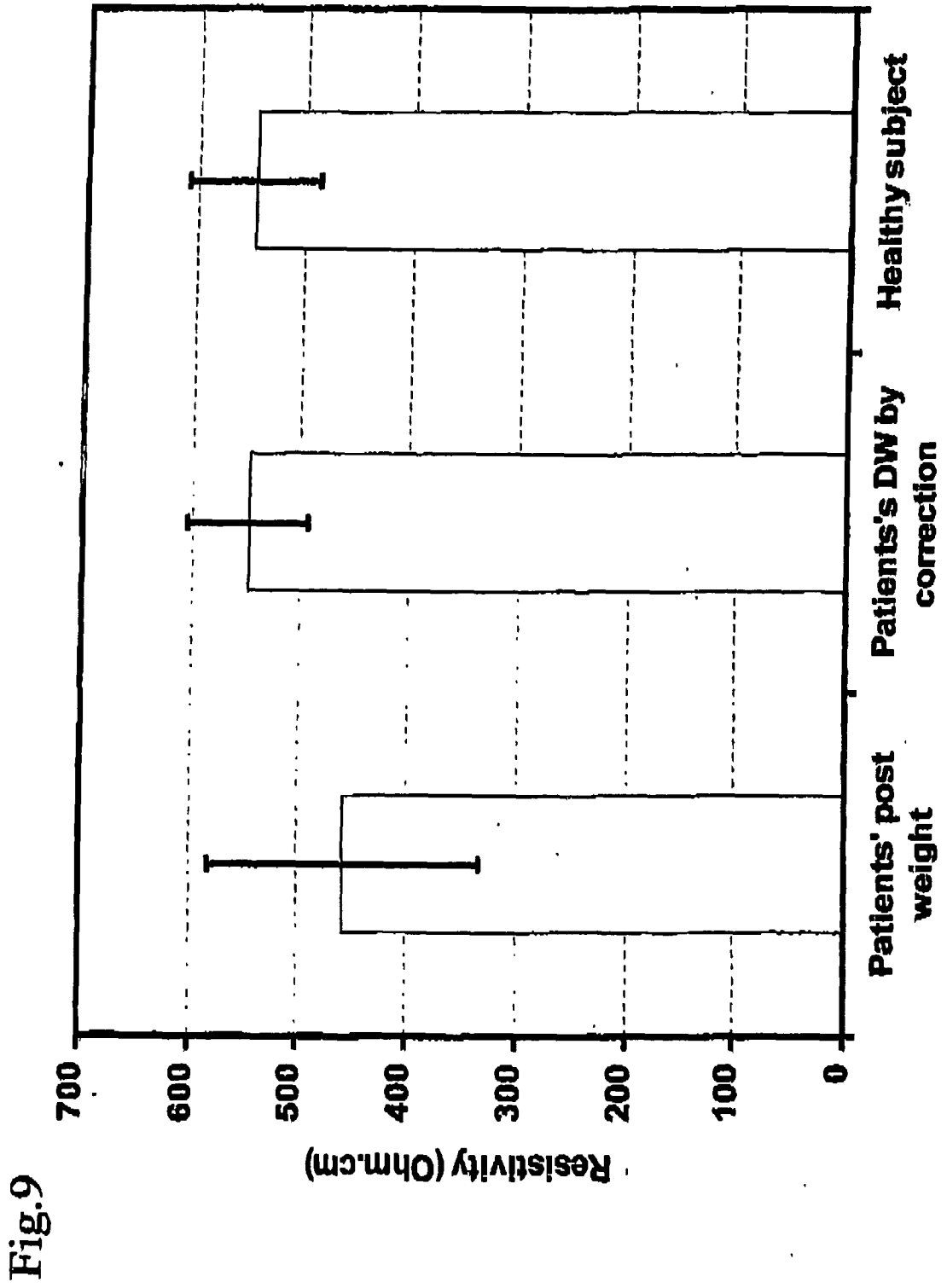

Fig.8



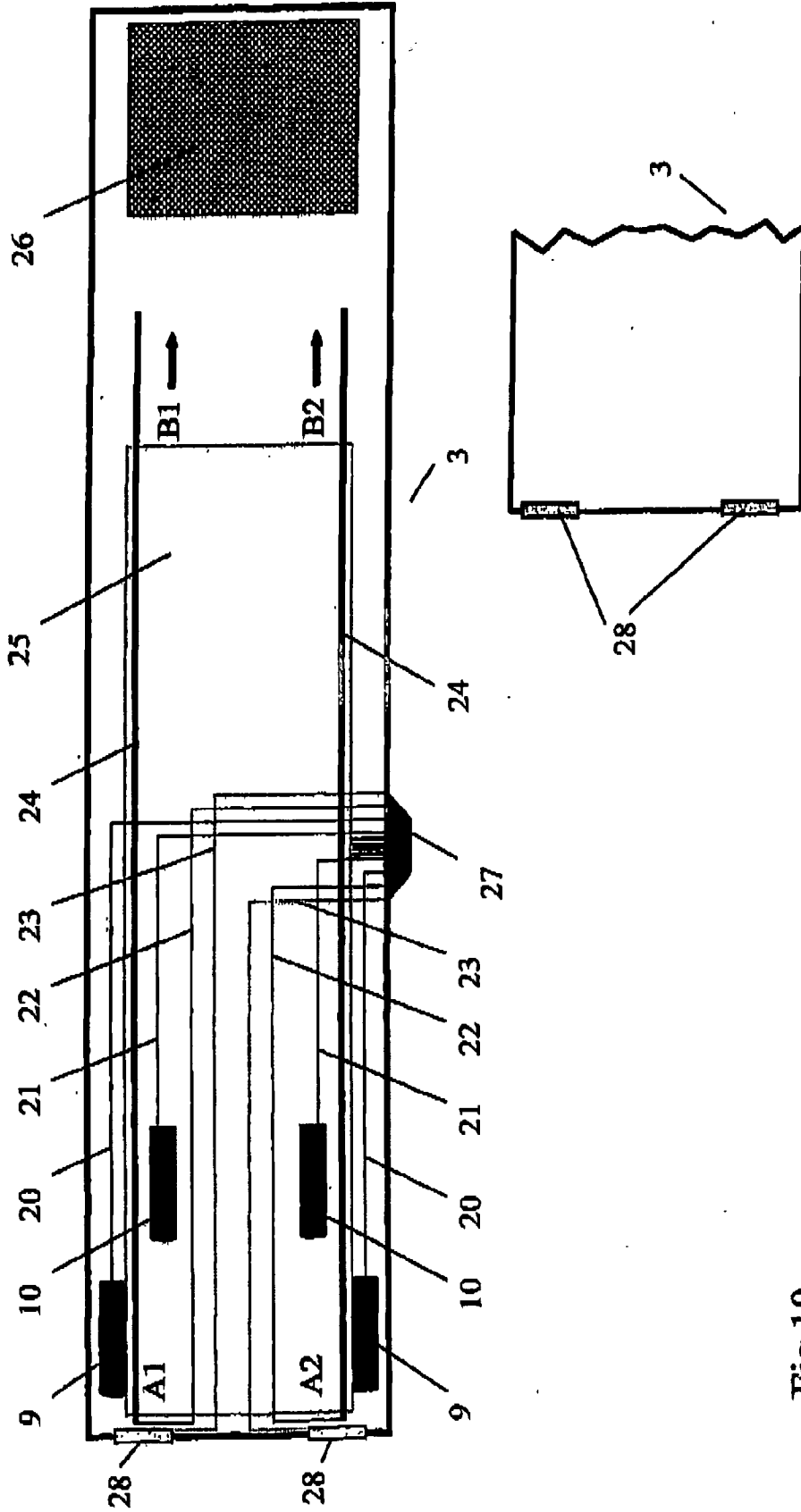

Fig.10

Fig 10A

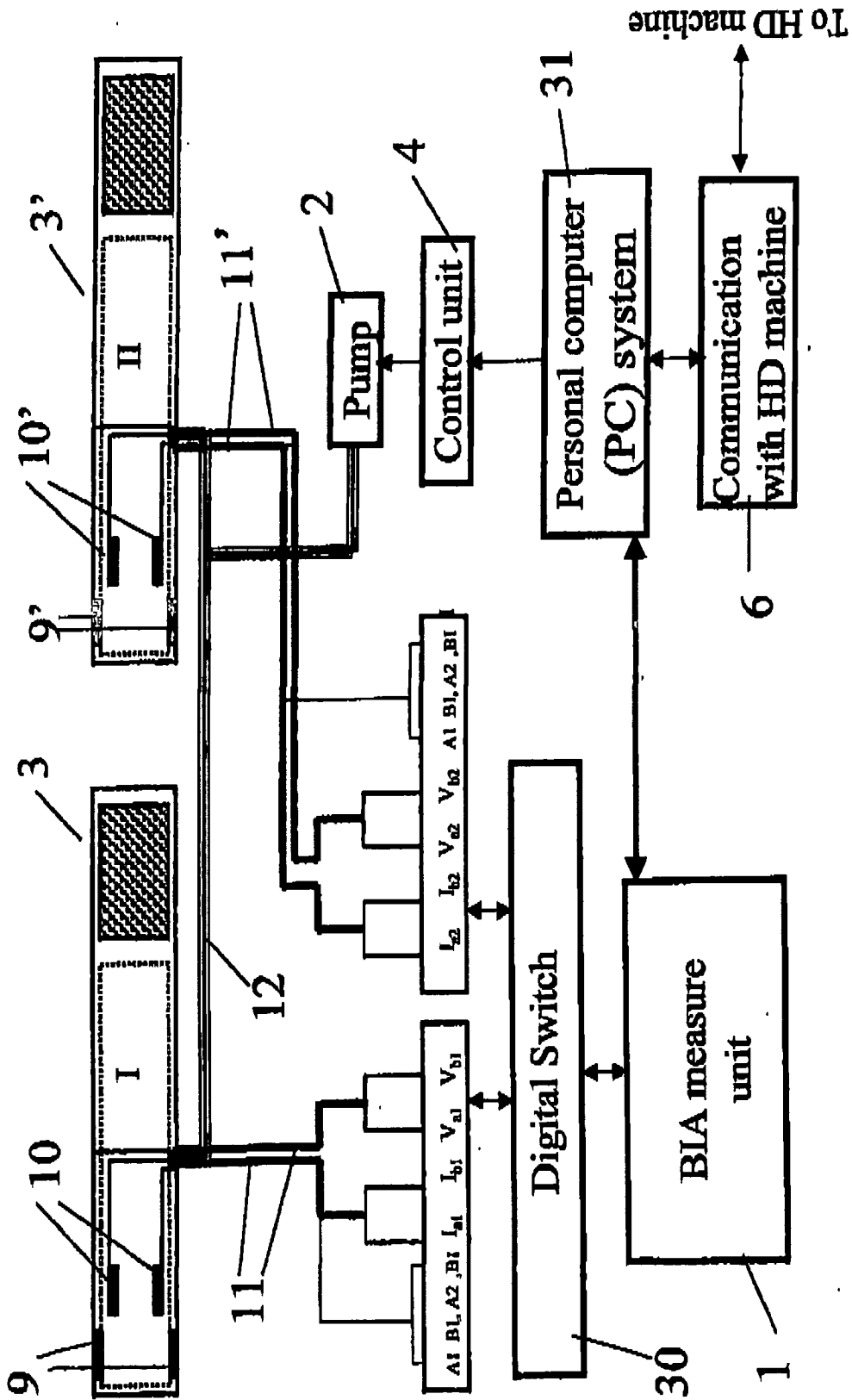

Fig. 11

REFERENCES CITED IN THE DESCRIPTION

This list of references cited by the applicant is for the reader's convenience only. It does not form part of the European patent document. Even though great care has been taken in compiling the references, errors or omissions cannot be excluded and the EPO disclaims all liability in this regard.

Patent documents cited in the description

- US 5580460 A, Polaschegg [0015]

Non-patent literature cited in the description

- **P.M. KOUW et al.** Assessment of post-dialysis dry weight: an application of the conductivity measurement method. *Kidney Int.*, 1992, vol. 41, 440-444 [0003]
- **J. G. WEBSTER.** Medical Instrumentation Application and Design. Wiley, 1998, 357-362 [0022]

专利名称(译)	用于透析患者的节段生物阻抗测量的装置和方法		
公开(公告)号	EP1938748A2	公开(公告)日	2008-07-02
申请号	EP2007024513	申请日	2001-08-13
[标]申请(专利权)人(译)	肾RES INST		
申请(专利权)人(译)	肾脏研究院		
当前申请(专利权)人(译)	肾脏研究院		
[标]发明人	ZHU FANSAN LEVIN NATHAN		
发明人	ZHU, FANSAN LEVIN, NATHAN		
IPC分类号	A61B5/05 A61M1/16 A61B5/053 A61B5/00 A61B5/022 A61B5/0245 A61B5/026 A61M1/14		
CPC分类号	A61B5/022 A61B5/0535 A61B5/0537 A61B5/4869 A61M1/16 A61M2205/3393 A61M2205/50		
代理机构(译)	爆竹SCHMIDT, 学生和合作伙伴		
优先权	09/638657 2000-08-14 US		
其他公开文献	EP1938748B1 EP1938748A3		
外部链接	Espacenet		

摘要(译)

本发明包括通过节段生物阻抗分析确定进行透析的患者的干体重的方法。在优选的实施方案中，通过与正常受试者的生物阻抗值比较或通过监测透析期间生物阻抗的变化来确定干体重。本发明的一个实施方案是用于确定透析期间干体重的装置。

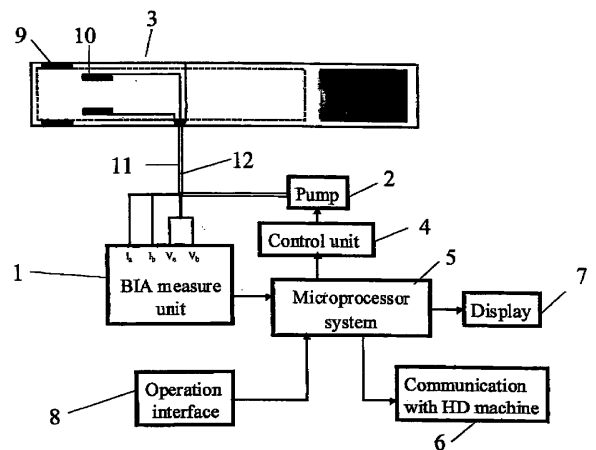

Fig.2