

(12) INTERNATIONAL APPLICATION PUBLISHED UNDER THE PATENT COOPERATION TREATY (PCT)

(19) World Intellectual Property  
Organization

International Bureau

(43) International Publication Date  
19 April 2018 (19.04.2018)



(10) International Publication Number  
**WO 2018/071715 A1**

(51) International Patent Classification:

A61B 5/00 (2006.01) A61B 5/11 (2006.01)

(21) International Application Number:

PCT/US2017/056405

(22) International Filing Date:

12 October 2017 (12.10.2017)

(25) Filing Language:

English

(26) Publication Language:

English

(30) Priority Data:

62/407,935 13 October 2016 (13.10.2016) US

(71) Applicant: MASIMO CORPORATION [US/US]; 52  
Discovery, Irvine, CA 92618 (US).

(72) Inventors: LEE, Sung, Uk; 52 Discovery, Irvine, CA  
92618 (US). AL-ALI, Ammar; 52 Discovery, Irvine, CA  
92618 (US). KASHIF, Faisal; 52 Discovery, Irvine, CA  
92618 (US).

(74) Agent: ALTMAN, Daniel, E.; Knobbe Martens, 2040  
Main Street, 14th Floor, Irvine, CA 92614 (US).

(81) Designated States (*unless otherwise indicated, for every  
kind of national protection available*): AE, AG, AL, AM,  
AO, AT, AU, AZ, BA, BB, BG, BH, BN, BR, BW, BY, BZ,  
CA, CH, CL, CN, CO, CR, CU, CZ, DE, DJ, DK, DM, DO,  
DZ, EC, EE, EG, ES, FI, GB, GD, GE, GH, GM, GT, HN,  
HR, HU, ID, IL, IN, IR, IS, JO, JP, KE, KG, KH, KN, KP,  
KR, KW, KZ, LA, LC, LK, LR, LS, LU, LY, MA, MD, ME,  
MG, MK, MN, MW, MX, MY, MZ, NA, NG, NI, NO, NZ,  
OM, PA, PE, PG, PH, PL, PT, QA, RO, RS, RU, RW, SA,  
SC, SD, SE, SG, SK, SL, SM, ST, SV, SY, TH, TJ, TM, TN,  
TR, TT, TZ, UA, UG, US, UZ, VC, VN, ZA, ZM, ZW.

(84) Designated States (*unless otherwise indicated, for every  
kind of regional protection available*): ARIPO (BW, GH,  
GM, KE, LR, LS, MW, MZ, NA, RW, SD, SL, ST, SZ, TZ,  
UG, ZM, ZW), Eurasian (AM, AZ, BY, KG, KZ, RU, TJ,  
TM), European (AL, AT, BE, BG, CH, CY, CZ, DE, DK,  
EE, ES, FI, FR, GB, GR, HR, HU, IE, IS, IT, LT, LU, LV,  
MC, MK, MT, NL, NO, PL, PT, RO, RS, SE, SI, SK, SM,  
TR), OAPI (BF, BJ, CF, CG, CI, CM, GA, GN, GQ, GW,  
KM, ML, MR, NE, SN, TD, TG).

Published:

— with international search report (Art. 21(3))

(54) Title: SYSTEMS AND METHODS FOR PATIENT FALL DETECTION

(57) Abstract: A patient monitoring system to help manage a patient that is at risk of falling is disclosed. The system includes a patient-worn wireless sensor that can be affixed to the patient's back that senses the patient's motion and wirelessly transmits information indicative of the sensed motion to a patient monitor. The patient monitor receives, stores, and processes the transmitted information to determine whether the patient has fallen or is about to fall. Upon such detection, the system can notify the patient's caretakers that the patient has fallen or is about to fall and therefore, is in need of immediate attention.



WO 2018/071715 A1

## SYSTEMS AND METHODS FOR PATIENT FALL DETECTION

### CROSS REFERENCE TO RELATED APPLICATIONS

**[0001]** This application claims priority to U.S. Provisional Patent Application No. 62/407,935, filed October 13, 2016, which is incorporated herein by reference in its entirety. Any and all applications, if any, for which a foreign or domestic priority claim is identified in the Application Data Sheet of the present application are hereby incorporated by reference under 37 CFR 1.57.

### FIELD

**[0002]** The present disclosure relates to the field of patient monitoring. More specifically, the disclosure describes among other things a wearable sensor that measures a patient's position, orientation, and movement and wirelessly communicates the measured information to a patient monitoring system.

### BACKGROUND

**[0003]** In clinical settings, such as hospitals, nursing homes, convalescent homes, skilled nursing facilities, post-surgical recovery centers, and the like, patients are frequently confined to bed for extended periods of time. Sometimes the patients are unconscious or sedated to such an extent that they have limited ability to change or control their position in the bed. These patients can be at risk of forming pressure ulcers, which pose a serious risk to the patient's health and well-being. Pressure ulcers, which may also be referred to as "bed sores," "pressure sores," and "decubitus ulcers," comprise injury to a patient's skin, and often the underlying tissue, which results from prolonged pressure forces applied to a site on the patient's body. Frequently, pressure ulcers develop on skin that covers bony areas of the body which have less muscle and/or fat tissue below the surface to distribute pressure applied thereto resulting from prolonged contact with the surface of a bed or chair. Examples of such body locations include the back or side of the head,

shoulders, shoulder blades, elbows, spine, hips, lower back, tailbone, heels, ankles, and skin behind the knees.

**[0004]** Pressure ulcers are caused by application of pressure at an anatomical site that occludes blood flow to the skin and other tissue near the location. Sustained pressure between a structural surface (such as a bed) and a particular point on the patient's body can restrict blood flow when the applied pressure is greater than the blood pressure flowing through the capillaries that deliver oxygen and other nutrients to the skin and other tissue. Deprived of oxygen and nutrients, the skin cells can become damaged, leading to tissue necrosis in as few as 2 to 6 hours. Despite commonly occurring in elderly and mobility-impaired populations, hospital-acquired pressure ulcers are considered to be preventable and have been termed "never events." Insurers have imposed restrictions on the amount they will reimburse a hospital for pressure ulcer treatment, and state and federal legislation now requires hospitals to report the occurrence of pressure ulcers in their facilities.

**[0005]** Risk factors for pressure ulcers can be categorized as modifiable and non-modifiable. Modifiable risk factors include actions that healthcare providers can take, while non-modifiable risk factors include aspects of patient health and behavior. It is valuable to document such non-modifiable risk factors so that caregivers can identify and attend to patients at risk of developing pressure ulcers. It is recommended that caregivers develop a documented risk assessment policy to predict the risk of a patient developing a pressure ulcer. Such an assessment can encompass all aspects of a patient's health and environment, and may employ commonly used measures in the field, such as the Braden and Norton scales. The risk assessment tool may be used to direct preventative strategies not only when a patient is at rest in his or her bed, but also when undergoing surgery.

**[0006]** Additional factors that can contribute to the formation of pressure ulcers include friction and shear forces. Friction can occur when skin is dragged across a surface which can happen when patients are moved, especially when the skin is moist. Such frictional forces can damage the skin and make it more vulnerable to injury, including formation of a pressure ulcer. A shear is when two

forces move in opposite directions. For example, when the head portion of a bed is elevated at an incline, the patient's spine, tailbone, and hip regions tend to slide downward due to gravity. As the bony portion of the patient's body moves downward, the skin covering the area can stay in its current position, thereby pulling in the opposite direction of the skeletal structure. Such shear motion can injure the skin and blood vessels at the site, causing the skin and other local tissue to be vulnerable to formation of a pressure ulcer.

**[0007]** An established practice for patients at risk of forming pressure ulcers is to follow a turning protocol by which the patient is periodically repositioned, or "turned" to redistribute pressure forces placed on various points of the patient's body. Individuals at risk for a pressure ulcer are to be repositioned regularly. It is commonly suggested that patients be repositioned every 2 hours at specific inclination angles, and that the method of doing so minimizes the amount of friction and shear on the patient's skin. A repositioning log can be maintained and include key information, such as the time, body orientation, and outcome.

**[0008]** Pressure ulcer prevention programs have been effective and can reduce long-term costs associated with treatment. A 2002 study employed a comprehensive prevention program in two long-term care facilities, costing \$519.73 per resident per month. Results of the program revealed pressure ulcer prevalence to be reduced by 87% and 76% in the two facilities. A later study found that prevention strategies were able to reduce pressure ulcer prevalence from 29.6% to 0% in a medical intensive care unit, and from 9.2% to 6.6% across all units of the hospital. These interventions employed strategies such as manual patient repositioning and logging, tissue visualization and palpation, pressure-reducing mattresses, and use of risk assessment tools.

**[0009]** Turning protocols, however, do not take into consideration position changes made by the patient between established turn intervals, which are neither observed nor recorded. Thus it is possible that in some circumstances, the act of following a turn protocol can have an unintended negative clinical effect.

## SUMMARY

**[0010]** This disclosure describes, among other things, embodiments of systems, devices, and methods for monitoring the position and orientation of a patient at risk of forming one or more pressure ulcers.

**[0011]** One aspect can include a system for monitoring an orientation of a patient's back to reduce a risk of the patient developing a pressure ulcer on a portion of the patient's body. The system can include a sensor and a patient monitor. The sensor can include an accelerometer, a processor, and a first wireless transceiver. The sensor can output a signal indicative of a possible change in an orientation of a back of said patient when said sensor is positioned on a portion of the patient's back. The patient monitor can include a signal processor, a memory device, a storage device, and a second wireless transceiver. The second wireless transceiver can receive said signal from said sensor positioned on the portion of the patient's back. The signal processor can process said signal to determine whether said possible change corresponds to an actual change in said orientation of the patient's back. When said actual change has occurred, the processor can record a patient turn event, compare said patient turn event with a patient turn protocol, and when said possible change is not said actual change and no patient turn event occurs according to the patient turn protocol, the patient monitor can notify a caregiver of a patient turn protocol violation. The signal processor can determine whether said possible change corresponds to said actual change includes being able to determine a difference between said orientation of said patient's back at a previous time and at a current time based at least on said signal, and when said difference is above a threshold, record said patient turn event.

**[0012]** The sensor can be affixed to the patient's back between shoulder blades of the patient. The portion of the patient's back can be an upper portion of the patient's back. The portion of the patient's back can be at approximately a center of the patient's back. The said signal processor of said patient monitor is can reset a patient orientation duration timer when said processor records said patient turn event.

**[0013]** The system can include a third wireless transceiver, said third wireless transceiver configured to receive said signal from said sensor and to transmit said signal to said patient monitor. The system can include a power supply for said third wireless transceiver different from a power supply for said sensor or said patient monitor. The sensor can include a gyroscope. The sensor can include an acoustic sensor. The sensor can include a temperature sensor. The sensor can include an ECG sensor. The sensor can include one or more of an acoustic sensor, a temperature sensor and an ECG sensor. The patient monitor can determine measurements of one or more of the following parameters: an acceleration, an angular velocity, a magnetic field, a respiration rate, a temperature, an impedance value, a moisture value, an oximetry value and an electrocardiogram. The portion of said patient's back can be approximately flat.

**[0014]** Another aspect of the present disclosure comprises a patient turn and movement monitoring system configured to help manage a patient that is at risk of forming one or more pressure ulcers. Some embodiments of the patient turn and monitoring system include a patient-worn, wireless sensor having one or more sensors configured to obtain information describing the patient's orientation and to wirelessly transmit information indicative of the sensed orientation information. The system also includes a patient monitor configured to receive, store, and process the information transmitted by the wireless sensor and to display and transmit information (or data) indicative of the patient's orientation to help caregivers manage the patient's risk of formation of one or more pressure ulcers. In some configurations, the wireless sensor is affixed to the patient's back. The patient turn and movement monitoring system can identify the present orientation of the patient and determine how long the patient has been in the present orientation. If the patient remains in an orientation beyond a predefined, clinician-prescribed patient orientation duration, the system can notify the patient and/or caretakers that the patient is due to be repositioned. In certain embodiments, a patient orientation duration timer is used to monitor such orientation times. In certain embodiments of the disclosed patient turn and movement monitoring system, a signal repeater, located within reception range of the wireless sensor, is used to receive and forward

the information indicative of the sensed orientation information from the wireless sensor to a network-based processing node.

**[0015]** According to another aspect of the present disclosure, the wireless sensor can be affixed to the patient's back between shoulder blades of the patient. According to another aspect of the present disclosure, the wireless sensor can be affixed to an upper portion of the patient's back.

**[0016]** Another aspect of the present disclosure includes a wireless sensor including one or more sensors configured to obtain position, orientation, and motion information from the patient. The one or more sensors can include an accelerometer, a gyroscope, and a magnetometer, which are configured to determine the patient's position and orientation in three-dimensional space. The wireless sensor is configured to wirelessly transmit the sensor data, and/or information representative of the sensor data, to a patient monitor. The patient monitor can be configured to process the received information, to display information indicative of, or derived from the received data, and to transmit information – including displays, alarms, alerts, and notifications – to a multi-patient monitoring system which may be located, for example, at a nurse's station.

**[0017]** Another aspect of the present disclosure is directed to a system and method for associating the wireless sensor with a patient monitor. In some embodiments, the wireless sensor includes an activation tab which, when removed, activates the wireless sensor. Upon activation, a wireless transceiver in the wireless sensor emits a low-power pairing signal having a pairing signal transmission range of up to approximately three inches. In some embodiments, the wireless sensor has a switch or button which, when depressed, places the wireless sensor in a pairing mode of operation, causing the wireless sensor to emit the low-power pairing signal. When the patient monitor is within range of the wireless sensor (e.g., within the about three-inch range), the wireless sensor and the patient monitor associate, thereby configuring the wireless sensor and patient monitor to communicate with each other. Once the pairing between the wireless sensor and the patient monitor is completed, the wireless sensor changes into a patient parameter sensing mode of operation in which the wireless sensor transmits a patient parameter sensing signal.

The patient parameter sensing signal has a patient signal transmission range that is substantially greater than the pairing signal transmission range. The wireless sensor is then in condition to be placed on the patient.

**[0018]** In some aspects of the present disclosure the patient's position and orientation are monitored and recorded. Once the wireless sensor is affixed to the patient's body, such as, for example, the patient's torso, sensor data corresponding to the patient's motion (*e.g.*, acceleration and angular velocity) are obtained, pre-processed, and transmitted to the patient monitor. The patient monitor stores and further processes the received data to determine the patient's orientation. Illustratively, the patient monitor can determine whether the patient is standing, sitting, or lying down in the prone, supine, left side, or right side positions.

**[0019]** In some embodiments, the patient monitor determines the precise orientation of the patient's body. For example, the patient monitor can determine the degree to which the patient's body is inclined, vertically and/or horizontally, thereby generating an accurate description of the patient's position relative to the support structure (such as a bed) upon which the patient lies.

**[0020]** In another aspect of the present disclosure the patient monitor stores the determined position and orientation information and keeps track of how long the patient remains in each determined position, thereby creating a continuous record of the patient's positional history. The patient monitor analyzes and processes the stored data to provide clinically-relevant, actionable information to the patient's care providers. Illustratively, the patient monitor counts the number of in-bed turns performed by the patient and monitors and displays the amount of time that has elapsed since the patient last turned. When the elapsed time exceeds a clinician-defined duration (*e.g.*, two hours), the patient monitor displays an indication that the maximum time between patient turns has been exceeded. The patient monitor can also transmit a notification to one or more clinicians responsible for caring for the patient via, for example, a multi-patient monitoring system, a clinician notification device, or the like. The patient monitor can also determine and display statistical information, such as the average, minimum, and maximum amount of time between turns for a given clinician-defined time period, such as for example,

twenty-four hours. The patient monitor can also determine and display the number of turns in the same position and orientation over a clinician-defined period of time. Similarly, the patient monitor can display the total amount of time the patient remained in each specific position within a clinician-defined period. Moreover, the patient monitor can determine the frequency and duration of periods during which the patient remained in clinically-defined acceptable positions.

**[0021]** In yet another aspect of the present disclosure the patient monitor determines the mobility status of the patient, *e.g.*, whether the patient is ambulatory, standing, sitting, reclining, or falling. In certain aspects, the wireless monitoring system can include an alert system to alert the caregiver that the patient is falling, getting out of bed, or otherwise moving in a prohibited manner or in a manner that requires caregiver attention. The alert can be an audible and/or visual alarm on the monitoring system, or the alert can be transmitted to a caregiver (*e.g.*, nurses' station, clinician device, pager, cell phone, computer, or otherwise). Illustratively, the patient monitor can display the patient's mobility status and transmit a notification that the patient is active and away from the bed. In some circumstances, the patient monitor can determine whether the patient contravenes a clinician's order, such as, for example, instructions to remain in bed, or to walk to the bathroom only with the assistance of an attendant. In such circumstances, a notification, alert, or alarm can be transmitted to the appropriate caregivers.

**[0022]** In certain aspects, the information received by the wireless sensor can be used to create a time-sequenced representation of the patient's movement. This representation can be displayed on the patient monitor or transmitted to a nurses' station or other processing nodes to enable the caregiver to monitor the patient. The time-sequenced representation can be viewed in real time and/or be recorded for playback. For example, if an alarm alerts the caregiver that the patient has fallen out of bed, the caregiver can access and review the historical sequence of the patient's movements prior to and during that period of time.

**[0023]** Another aspect of the present disclosure is directed to predicting a patient's risk of falling based on the patient's gait and other information (such as, for example, the patient's current medication regimen). When the patient monitor

determines that the patient's risk of falling is above a predetermined threshold, the patient monitor can issue an alarm or alert to notify care providers of the identified risk in an effort to anticipate and therefore prevent a patient fall. Additionally, the patient monitor can determine when a patient has fallen and issue the appropriate alarms and alerts to summon care provider assistance.

**[0024]** In an aspect of the present disclosure the patient monitor accesses the patient's health records and clinician input via a network. Illustratively, the patients' positional history data, analyzed in view of the patient's health records, may reveal or suggest a turning protocol (or other treatment protocol) that will likely yield favorable clinical outcomes for the particular patient. Accordingly, the patient monitor analyzes the accessed information in conjunction with the received information from the wireless sensor to determine a recommended patient turn protocol (or other treatment protocol) for the patient.

**[0025]** In still another aspect of the present disclosure, the patient monitor assesses caregiver and facility compliance with the clinician-defined patient turn protocol established for the patient. For example, the patient monitor can identify the number of times that the patient remains in a position for a period greater than the prescribed duration, indicating a patient turn protocol violation, as well as the length of each such overexposure. The patient monitor can also track the clinician's response time upon issuance of a notification, alert, or alarm.

**[0026]** According to another aspect of the present disclosure, care provider workflow productivity, efficiency, and effectiveness can be determined, based on aggregated positional history data corresponding to multiple patients wherein each patient is equipped with the disclosed wireless sensor. Additionally, care for patients in a particular location, such as a hospital ward or nursing home floor where the ratio of patients to staff is relatively high, can be prioritized based on the determined risk of formation of pressure ulcers. Thus, patients determined to have the highest risk are designated to receive attention first.

**[0027]** In yet another aspect of the present disclosure, the wireless sensor includes sensors to obtain additional physiological measurements from the patient. For example, the wireless sensor can include a temperature sensor configured to

measure the patient's body core body temperature by insulating the patient's skin surface around the temperature sensor. As a result of the insulation surrounding the temperature sensor, the natural temperature difference between the patient's skin surface and body core reach equilibrium, thereby arriving at the patient's body core temperature (which is typically higher in temperature than the patient's skin surface). The wireless sensor can also include an acoustic respiration sensor configured to sense vibrational motion generated by the patient's chest. The acoustic respiration sensor is configured to mechanically transmit the sensed vibrations through rigid structures of the device to the accelerometer. Processing of the accelerometer signal can provide, among other things, the patient's respiration and heart rates. An electrocardiogram (ECG) sensor, configured to sense electrical signals from two or more electrodes in electrical contact with the patient's chest may also be included in the wireless sensor. The ECG signal can be processed to detect arrhythmias, such as bradycardia, tachyarrhythmia, ventricular fibrillation and the like. Additionally, the accelerometer signal (containing information indicative of the mechanically-transmitted vibrations from the acoustic respiration sensor) and/or the ECG signal can be processed to identify respiratory distress or dysfunction, including without limitation, snoring, coughing, choking, wheezing, apneic events, and airway obstruction.

**[0028]** In another aspect of the present disclosure, the patient monitor can determine a score that describes the patient's wellness/sickness state, which may also be referred to as a "Halo Index." Illustratively, the patient monitor accesses and analyzes the patient's health records, clinician input, positional history data provided by the wireless sensor, surface structure pressure data, and other physiological parameter data collected and provided by the wireless sensor (such as, by way of non-limiting example, the patient's temperature, respiration rate, heart rate, ECG signal, and the like) to assess the patient's overall health condition.

**[0029]** In an aspect of the present disclosure, the patient monitor accesses information provided by the patient's support structure (e.g., bed, mattress, bed sheet, mattress pad, and the like) to determine the extent of pressure forces exerted on particular anatomical sites of the patient's body. Illustratively, the

patient's support structure can be configured with an array of pressure sensors that measure the pressure force exerted on the support structure by the patient at specific locations. The patient monitor can analyze the patient's postural history data in conjunction with the information provided by the support structure to determine a likelihood of pressure ulcer formation at a specific anatomical location based on the measured amount of pressure exerted on the anatomical location multiplied by the amount of time the anatomical location has been under such pressure. When the evaluated risk exceeds a predetermined threshold, the patient monitor can issue an alarm and/or an alert to reposition the patient so as to avoid formation of a pressure ulcer in the specified anatomical location. Additionally, the patient monitor can suggest particular positions and/or a patient turn protocol based on the combined analysis of pressure force exerted and length of time under such pressure.

**[0030]** For purposes of summarizing the disclosure, certain aspects, advantages, and novel features have been described herein. Of course, it is to be understood that not necessarily all such aspects, advantages, or features will be embodied in any particular embodiment.

#### BRIEF DESCRIPTION OF THE DRAWINGS

**[0031]** Various embodiments will be described hereinafter with reference to the accompanying drawings. The drawings and the associated descriptions are provided to illustrate embodiments of the present disclosure and do not limit the scope of the claims. In the drawings, similar elements have similar reference numerals.

**[0032]** FIG. 1A is a perspective view of an embodiment of the disclosed patient monitoring system including a patient-worn wireless sensor in proximity to a patient monitor.

**[0033]** FIG. 1B is a functional block diagram of an embodiment of the display of the disclosed patient monitor.

**[0034]** FIG. 1C is a functional block diagram of an embodiment of the disclosed patient monitoring system.

**[0035]** FIG. 1D is a functional block diagram of an embodiment of the disclosed patient monitoring system.

**[0036]** FIG. 1E is a functional block diagram of an embodiment of the disclosed patient monitoring system.

**[0037]** FIG. 1F is a functional block diagram of an embodiment of the disclosed patient monitoring system.

**[0038]** FIG. 2A is a functional block diagram of an embodiment of the disclosed wireless sensor.

**[0039]** FIG. 2B is a functional block diagram of an embodiment of the disclosed wireless sensor including optional sensing components.

**[0040]** FIG. 3A is a schematic exploded perspective view of an embodiment of the disclosed wireless sensor.

**[0041]** FIG. 3B is a schematic assembled perspective view of the embodiment of the disclosed wireless sensor of FIG. 3A.

**[0042]** FIG. 3C is a schematic side view of the embodiment of the disclosed wireless sensor of FIGS. 3A and 3B.

**[0043]** FIG. 4A is a schematic cross-sectional view of an embodiment of the disclosed wireless sensor which includes a temperature sensor.

**[0044]** FIG. 4B is a schematic bottom view of the embodiment of the disclosed wireless sensor of FIG. 4A.

**[0045]** FIG. 4C is a schematic exploded perspective view of the embodiment of the disclosed wireless sensor of FIGS. 4A-B.

**[0046]** FIG. 5A is a schematic cross-sectional view of an embodiment of the disclosed wireless sensor which includes an acoustic respiration sensor.

**[0047]** FIG. 5B is a schematic bottom view of the embodiment of the disclosed wireless sensor of FIG. 5A.

**[0048]** FIG. 5C is a schematic exploded perspective view of the embodiment of the disclosed wireless sensor of FIGS. 5A-B.

**[0049]** FIG. 6A is a schematic cross-sectional view of an embodiment of the disclosed wireless sensor which includes a temperature sensor and an acoustic respiration sensor.

**[0050]** FIG. 6B is a schematic bottom view of the embodiment of the disclosed wireless sensor of FIG. 6A.

**[0051]** FIG. 6C is a schematic exploded perspective view of the embodiment of the disclosed wireless sensor of FIGS. 6A-B.

**[0052]** FIG. 7A is a perspective view of an embodiment of the disclosed patient monitoring system including a patient-worn wireless sensor having an ECG sensor in proximity to a patient monitor.

**[0053]** FIG. 7B is a schematic assembled perspective view of the embodiment of the disclosed wireless sensor of FIG. 7A.

**[0054]** FIG. 7C is a schematic side view of the embodiment of the disclosed wireless sensor of FIGS. 7A and 7B.

**[0055]** FIG. 7D is a cross-sectional view of an embodiment of the disclosed wireless sensor of FIGS. 7A-C.

**[0056]** FIG. 7E is a schematic bottom perspective view of the embodiment of the disclosed wireless sensor of FIGS. 7A-D.

**[0057]** FIG. 7F is a schematic exploded perspective view of the embodiment of the disclosed wireless sensor of FIGS. 7A-7E.

**[0058]** FIG. 8A is a schematic exploded perspective view of an embodiment of the disclosed wireless sensor having a temperature sensor, an acoustic respiration sensor, and an ECG sensor.

**[0059]** FIG. 8B is a schematic bottom view of the disclosed wireless sensor of FIG. 8A.

**[0060]** FIG. 9 is a flow diagram describing a process to associate a wireless sensor with a patient monitor according to an embodiment of the present disclosure.

**[0061]** FIG. 10 is a flow diagram describing a process to determine whether a patient has changed orientation according to an embodiment of the present disclosure.

**[0062]** FIG. 11A is an exemplary plot of processed accelerometer data over time used to determine a patient's orientation according to an embodiment of the present disclosure.

**[0063]** FIG. 11B is an exemplary plot of the duration of a patient's orientation according to an embodiment of the present disclosure.

**[0064]** FIG. 12 is a flow diagram describing a process to determine whether a patient has fallen according to an embodiment of the present disclosure.

**[0065]** FIGS. 13A-13F illustrate embodiments of displays reflecting a patient's position according to an embodiment of the present disclosure.

**[0066]** FIG. 14 illustrates an example display of a patient monitor incorporating the icons illustrated in FIGS. 13A-F according to an embodiment of the present disclosure.'

**[0067]** FIGS. 15A-15H illustrate various configurations of a room display displayed on a patient display monitor according to an embodiment of the present disclosure.

**[0068]** FIG. 16 illustrates an example method according to an embodiment of the present disclosure.

**[0069]** FIGS. 17A-17B illustrate an example configuration of a wireless sensor positioned on a patient's back.

#### DETAILED DESCRIPTION

**[0070]** Embodiments of the present disclosure will now be described with reference to the accompanying figures, wherein like numerals refer to like elements throughout. The following description is merely illustrative in nature and is in no way intended to limit the disclosure, its application, or uses. It should be understood that steps within a method may be executed in different order without altering the principles of the present disclosure. Furthermore, embodiments disclosed herein can include several novel features, no single one of which is solely responsible for its desirable attributes or which is essential to practicing the systems, devices, and methods disclosed herein.

**[0071]** The present disclosure relates to systems, devices, methods, and computer-readable media to monitor and manage the position, orientation, and movement of a patient who is at risk of forming one or more pressure ulcers. In one embodiment, the system comprises a patient-worn, wireless sensor including one or

more sensors configured to obtain position, orientation and movement information from the patient. The one or more sensors can include one or more accelerometers, gyroscopes, and magnetometers (*i.e.*, compasses). Illustratively, the sensors continuously or periodically (*e.g.*, every second) obtain information that describes the patient's orientation in three dimensions. The wireless sensor includes a processor that is configured to process the obtained sensor information. The wireless sensor also includes a transceiver configured to wirelessly transmit the processed sensor data, and/or information representative of the sensor data, to a patient monitor (or other processing device) for further processing. The patient monitor can be configured to store and further process the received information, to display information indicative of or derived from the received data, and to transmit information -- including displays, alarms, alerts, and notifications -- to other patient care systems including a multi-patient monitoring system which may be accessible from, for example, a nurses' station.

**[0072]** FIG. 1A is a perspective illustration of an embodiment of the disclosed patient monitoring system 100 in a clinical setting. The patient monitoring system 100 includes a wireless sensor 102 worn by a patient, in proximity to a patient monitor 106 located on a table 116 at the side of the patient's bed 118. The wireless sensor 102 may also be referred to herein as "a wireless physiological sensor 102," "a patient-worn sensor 102," "a movement sensor 102," and "a wearable wireless sensor 102." The wireless sensor 102 includes one or more sensors configured to measure the patient's position, orientation, and motion. In some embodiments, the wireless sensor 102 includes an accelerometer configured to measure linear acceleration of the patient and a gyroscope configured to measure angular velocity of the patient. The measured linear acceleration and angular velocity information can be processed to determine the patient's orientation in three dimensions. In some embodiments, a magnetometer is included in the wireless sensor 102 to measure the Earth's gravitational field. Information measured by the magnetometer can be used to improve accuracy of the determined orientation of the patient.

**[0073]** The wireless sensor 102 also includes a wireless transceiver 206 (shown in FIGS. 2A and 2B) which can transmit to the patient monitor 106 information representative of sensor data obtained by the wireless sensor 102 from the patient. Advantageously, the patient is not physically coupled to the bedside patient monitor 106 and can therefore move freely into different positions on the bed 118.

**[0074]** In accordance with certain embodiments of the present disclosure, the wireless sensor 102 is affixed to the skin of the patient's body under the patient's garment as reflected in FIG. 1A by the phantom drawing of the wireless sensor 102. More particularly, the wireless sensor 102 can be placed on the patient's chest over the patient's manubrium, the broad upper portion of the sternum. In this position, the wireless sensor 102 is approximately centered relative to the longitudinal axis of the patient's body and near the patient's center of mass, a position that is useful in determining the patient's orientation when, for example, the patient is in bed.

**[0075]** The wireless sensor 102 can be affixed to the patient's skin using any form of medically-appropriate adherent material, including a pressure-sensitive adhesive that is coated or applied to the bottom surface of the wireless sensor 102. One skilled in the art will appreciate that many other materials and techniques can be used to affix the wireless sensor 102 to the patient without departing from the scope of the present disclosure.

**[0076]** Frequently in clinical settings, multiple medical sensors are attached or adhered to a patient to concurrently monitor multiple physiological parameters. Some examples of medical sensors include, but are not limited to, position, orientation, and movement sensors, temperature sensors, respiration sensors, heart rate sensors, blood oxygen sensors (such as pulse oximetry sensors), acoustic sensors, EEG sensors, ECG sensors, blood pressure sensors, sedation state sensors, to name a few. Typically, each sensor that is attached to a patient transmits, often by cable, the obtained physiological data to a nearby monitoring device configured to receive and process the sensor data, and transform it into clinical information to be used by the care providers to monitor and manage the patient's condition. When a patient is concurrently monitored by several

physiological sensors, the number of cables and the number of bedside monitoring devices used can be excessive and can limit the patient's freedom of movement and impede care providers' access to the patient. The cables connecting the patient to the bedside monitoring devices can also make it more difficult to move the patient from room to room or to switch to different bedside monitors.

**[0077]** Advantageously, the disclosed wireless sensor 102 can transmit data, wirelessly, to a patient data processing environment 105 in which the sensor data can be processed using one or more processing capabilities. As illustrated in FIG. 1A, the wireless sensor 102 transmits data via a wireless communications link 104. The wireless communications link 104 can be received by the bedside patient monitor 106, and/or by an extender/repeater 107. Both the patient monitor 106 and expander/repeater 107 provide access, by way of high-speed and reliable communications interfaces, to the patient data processing environment 105. For illustration purposes, both the patient monitor 106 and the extender/repeater 107 are illustrated in FIG. 1A. However, typically only one such device is required to establish a wireless connection between the wireless sensor 102 and the patient data processing environment 105. The wireless communications link 104 can use any of a variety of wireless technologies, such as Wi-Fi (802.11x), Bluetooth, ZigBee, cellular telephony, infrared, RFID, satellite transmission, proprietary protocols, combinations of the same, and the like. The wireless sensor 102 can be configured to perform telemetry functions, such as measuring and reporting position, orientation, and movement information about the patient. According to one embodiment, the wireless sensor 102 uses the Bluetooth wireless communications standard to communicate wirelessly with the patient monitor 106.

**[0078]** The extender/repeater 107 can receive sensor data from the wireless sensor 102 by way of the wireless communications link 104 and forward the received sensor data, via the network 108, to one or more processing nodes within the patient data processing environment 105. For example, the extender/repeater 107 can forward the received sensor data to a patient monitor 106 that might be located beyond the range of the wireless communications link 104 of a particular wireless sensor 102. Alternatively, the extender/repeater 107 can route the sensor

data to other processing nodes within the patient data processing environment 105, such as, for example, a multi-patient monitoring system 110 or a nurses' station system 113. A skilled artisan will appreciate that numerous processing nodes and systems can be used to process the data transmitted by the wireless sensor 102.

**[0079]** FIG. 1A also illustrates an embodiment of the patient monitor 106, which may also be referred to herein as “a processing device 106,” “a portable computing device 106,” and “a patient monitoring device 106.” Examples of a patient monitor 106 are disclosed in U.S. Pat. Pub. Nos. 2013/0262730 and 2015/0099955, assigned to the assignee of the present disclosure, and which are incorporated by reference herein in their entirety. The patient monitor 106 is a processing device, and therefore includes the necessary components to perform the functions of a processing device, including at least one processor, a memory device, a storage device, input/output devices, and communications connections, all connected via one or more communication buses. Thus, in certain embodiments, the patient monitor 106 is configured to process the sensor data provided by the wireless sensor 102. In other embodiments, processing of the sensor data can be performed by other processing nodes within the patient data processing environment 105. The patient monitor 106 is configured to wirelessly communicate with the wireless sensor 102. The patient monitor 106 includes a display 120, and a docking station, which is configured to mechanically and electrically mate with a portable patient monitor 122 also having a display 130. The patient monitor 106 is housed in a movable, mountable, and portable housing formed in a generally upright, inclined shape configured to rest on a horizontal flat surface, as shown in FIG. 1A. Of course, a person skilled in the art will appreciate that the housing can be affixed in a wide variety of positions and mountings and can comprise a wide variety of shapes and sizes.

**[0080]** In an embodiment, the display 120, alone or in combination with the display 130 of the portable patient monitor 122, may present a wide variety of measurement and/or treatment data in numerical, graphical, waveform, or other display indicia. For example, the display 120 can display a variety of patient-specific configurations and/or parameters, such as the patient's weight, age, type of

treatment, type of disease, type of medical condition, nutrition, hydration and/or length of stay, among others. In an embodiment, the display 120 occupies much of a front face of the housing, although an artisan will appreciate the display 120 may comprise a table or tabletop horizontal configuration, a laptop-like configuration, or the like. Other embodiments may include communicating display information and data to a tablet computer, smartphone, television, or any display system recognizable to an artisan. Advantageously, the upright inclined configuration of the patient monitor 106, as illustrated in FIG. 1A, displays information to a caregiver in an easily viewable manner.

**[0081]** The portable patient monitor 122 of FIG. 1A may advantageously include an oximeter, co-oximeter, respiratory monitor, depth of sedation monitor, noninvasive blood pressure monitor, vital signs monitor or the like, such as those commercially available from Masimo Corporation of Irvine, CA, and/or disclosed in U.S. Pat. Pub. Nos. 2002/0140675, 2010/0274099, 2011/0213273, 2012/0226117, 2010/0030040; U.S. Pat. App. Ser. Nos. 61/242,792, 61/387457, 61/645,570, 13/554,908 and U.S. Pat. Nos. 6,157,850, 6,334,065, the contents of which are incorporated herein by reference in their entireties. The portable patient monitor 122 may communicate with a variety of noninvasive and/or minimally invasive devices such as, by way of non-limiting example, wireless sensor 102, optical sensors with light emission and detection circuitry, acoustic sensors, devices that measure blood parameters from a finger prick, cuffs, ventilators, and the like. The portable patient monitor 122 may include its own display 130 presenting its own display indicia. The display indicia may change based on a docking state of the portable patient monitor 122. When undocked, the display 130 may include parameter information and may alter its display orientation based on information provided by, for example, a gravity sensor or an accelerometer. Although disclosed with reference to particular portable patient monitors 122, an artisan will recognize from the disclosure herein there is a large number and wide variety of medical devices that may advantageously dock with the patient monitor 106.

**[0082]** FIG. 1B is a functional block diagram of an embodiment of the display 120 of the disclosed patient monitor 106 and the display 130 of the portable

patient monitor 122. Display 120 of the patient monitor 106 can be configured to present patient physiological data 124, patient turn data 126, and/or additional, optional patient data 128. Patient physiological data can include, by way of non-limiting example, oxygen saturation, pulse rate, respiration rate, fractional arterial oxygen saturation, total hemoglobin, plethysmograph variability index, methemoglobin, carboxyhemoglobin, perfusion index, and oxygen content. Advantageously, the display 120 is configurable to permit the user to adjust the manner by which the physiologic parameters 124, patient turn data 126, and optional patient data 128 are presented on the display 120. In particular, information of greater interest or importance to the clinician may be displayed in larger format and may also be displayed in both numerical and graphical formats to convey the current measurement as well as the historical trend of measurements for a period of time, such as, for example, the preceding hour.

**[0083]** As illustrated by dotted lines in FIG. 1B, the display 130 of the portable patient monitor 130 is an optional feature of the patient monitor 106 which may be configured to present patient physiological data 134, patient turn data 136, and additional, optional patient data 138.

**[0084]** FIG. 1C is a simplified functional block diagram of an embodiment of the disclosed patient monitoring system 100. The system includes the patient-worn wireless sensor 102 having one or more sensors, a wireless communications link 104, through which sensor data from the wireless sensor 102 accesses the patient data processing environment 105 which includes a patient monitor 106, a communications network 108, a multi-patient monitoring system 110, a hospital or facility information system 112, one or more nurses' station systems 113, and one or more clinician devices 114. An artisan will appreciate that numerous other computing systems, servers, processing nodes, display devices, printers, and the like can be included in the disclosed patient monitoring system 100.

**[0085]** The wireless sensor 102 is worn by a patient who has been determined to be at risk of forming one or more pressure ulcers, *e.g.*, a patient who is confined to bed for an extended period of time. The wireless sensor 102 is capable of monitoring on a continuous or periodic (*e.g.*, every second) basis the

orientation of the patient to help determine whether the patient is repositioned frequently enough to reduce the patient's risk of forming a pressure ulcer. In certain embodiments, the wireless sensor 102 minimally processes measured acceleration and/or angular velocity data and wirelessly transmits the minimally-processed data to the patient monitor 106 by way of the wireless communications link 104.

**[0086]** The wireless sensor 102 and the patient monitor 106 can be configured to utilize different wireless technologies to form the wireless communications link 104. In certain scenarios, it may be desirable to transmit data over Bluetooth or ZigBee, for example, when the distance between the wireless sensor 102 and the patient monitor 106 is within range of Bluetooth or ZigBee communication. Transmitting data using Bluetooth or ZigBee is advantageous because these technologies require less power than other wireless technologies. Accordingly, longevity of embodiments of the disclosed wireless sensor 102 using batteries may be increased by using Bluetooth or ZigBee protocols.

**[0087]** In other scenarios, it may be desirable to transmit data using Wi-Fi or cellular telephony, for example, when the distance between the wireless sensor 102 and the patient monitor 106 is out of range of communication for Bluetooth or ZigBee. A wireless sensor 102 may be able to transmit data over a greater distance using Wi-Fi or cellular telephony than other wireless technologies. In still other scenarios, it may be desirable to transmit data using a first wireless technology and then automatically switching to a second wireless technology in order to maximize data transfer and/or energy efficiency.

**[0088]** In some embodiments, the wireless sensor 102 automatically transmits data over Bluetooth or ZigBee when the wireless sensor 102 is within a pre-determined distance from the bedside patient monitor 106. The wireless sensor 102 automatically transmits data over Wi-Fi or cellular telephony when the wireless sensor 102 is beyond a pre-determined distance away from the bedside patient monitor 106. In certain embodiments, the wireless sensor 102 can automatically convert from Bluetooth or ZigBee to Wi-Fi or cellular telephony, and vice versa, depending on the distance between the wireless sensor 102 and the bedside patient monitor 106.

**[0089]** In some embodiments, the wireless sensor 102 automatically transmits data over Bluetooth or ZigBee when the Bluetooth or ZigBee signal strength is sufficiently strong or when there is interference with Wi-Fi or cellular telephony. The wireless sensor 102 automatically transmits data over Wi-Fi or cellular telephony when the Bluetooth or ZigBee signal strength is not sufficiently strong. In certain embodiments, the wireless sensor 102 can automatically convert from Bluetooth or ZigBee to Wi-Fi or cellular telephony, and vice versa, depending on signal strength.

**[0090]** The patient monitor 106 can be operable to receive, store and process the measured acceleration and angular velocity data transmitted by the wireless sensor 102 to determine the patient's orientation. Once determined, the patient monitor 106 can display the patient's current orientation. In some embodiments, the patient monitor 106 displays the patient's current orientation along with the patient's previous orientations over time, thereby providing the user the ability to view a historical record of the patient's orientation. In certain embodiments, *e.g.*, as illustrated in FIGS. 13A-F and 14, the patient orientation is displayed by icons, such stick figures, enabling the clinician to readily understand the patient's present positional state and the patient's positional history. The patient monitor 106 can also be configured to keep track of the length of time the patient remains in a particular orientation. In some embodiments the patient monitor 106 displays the amount of time the patient has been in the current orientation. Additionally, the patient monitor 106 can determine when the patient remains in a particular orientation for a duration greater than that prescribed by a clinician according to a repositioning protocol. Under such conditions, the patient monitor 106 can issue alarms, alerts, and/or notifications to the patient and/or to caregivers indicating that the patient should be repositioned to adhere to the prescribed repositioning protocol to reduce the risk of pressure ulcer formation.

**[0091]** As illustrated in FIG. 1C, the patient monitor 106 communicates over a network 108 with a patient data processing environment 105 that includes a multi-patient monitoring system 110, a hospital/facility system 112, nurses' station systems 113, and clinician devices 114. Examples of network-based clinical

processing environments, including multi-patient monitoring systems 110, are disclosed in U.S. Pat. Pub. Nos. 2011/0105854, 2011/0169644, and 2007/0180140, which are incorporated herein by reference in their entirety. In general, the multi-patient monitoring system 110 communicates with a hospital/facility system 112, the nurses' station systems 113, and clinician devices 114. The hospital/facility system 112 can include systems such as electronic medical record (EMR) and/or and admit, discharge, and transfer (ADT) systems. The multi-patient monitoring system 110 may advantageously obtain through push, pull or combination technologies patient information entered at patient admission, such as patient identity information, demographic information, billing information, and the like. The patient monitor 106 can access this information to associate the monitored patient with the hospital/facility systems 112. Communication between the multi-patient monitoring system 110, the hospital/facility system 112, the nurses' station systems 113, the clinician devices 114, and the patient monitor 106 may be accomplished by any technique recognizable to an artisan from the disclosure herein, including wireless, wired, over mobile or other computing networks, or the like.

**[0092]** FIG. 1D is a simplified functional block diagram of the disclosed patient monitoring system 100 of FIG. 1C expanded to illustrate use of multiple wireless sensors 102 with multiple patients within a caretaking environment. Advantageously, the patient monitoring system 100 can provide individual patient information on, for example, a patient monitor 106, as well as aggregated patient information on, for example, a nurses' station server or system 114. Thus a caretaker can have an overview of positional information corresponding to a population of patients located, for example, in a hospital floor or unit.

**[0093]** In some circumstances, there may not be the need, desire, or resources available to employ a bedside patient monitor 106 associated with a wireless sensor 102 being worn by a patient. For example, the clinical environment might be staffed such that patient data are collected, analyzed, displayed, and monitored at a central observation station, such as a nurses' station, rather than at the patient's bedside. Moreover, when the information is to be accessed by a clinician at the bedside, portable clinician devices 114, such as, for example, tablets,

PDA's or the like, may be used by caregivers to access the required patient-specific information while at the patient's bedside.

**[0094]** In such situations, as illustrated in FIGS. 1E and 1F, the wireless sensor 102 can communicate to the various systems of the clinical computing environment by way of a signal extender/repeater 107. The extender/repeater 107 is located within range of the wireless sensor 102 (*e.g.*, near the patient's bed 118) and configured to relay data, via the network 108, between the wireless sensor 102 and one or more computing systems capable of processing, storing, displaying, and/or transmitting the data collected by the wireless sensor 102. Advantageously, a relatively low cost extender/repeater 107 can be used to receive signals transmitted from one or more wireless sensors 102 over the wireless communications link(s) 104 using a shorter-range, lower-power-consuming transmission mode, such as for example, Bluetooth or ZigBee. The extender/repeater 107 can then retransmit the received signals to one or more computing systems in the patient data processing environment 105 over the network 108. In accordance with some embodiments, the extender/repeater 107 is a Bluetooth-to-Ethernet gateway that retransmits signals received from the wireless sensor 102 to computing nodes, such as, for example, the multi-patient monitoring system 110, over the network 108. In some embodiments, the extender/repeater 107 is a Bluetooth-to-WiFi bridge that provides access to the network 108 for the wireless sensor 102. Of course, a skilled artisan will recognize that there are numerous ways to implement the extender/repeater 107.

**[0095]** FIG. 2A illustrates a simplified hardware block diagram of an embodiment of the disclosed wireless sensor 102. As shown in FIG. 2A, the wireless sensor 102 can include a processor 202, a data storage device 204, a wireless transceiver 206, a system bus 208, an accelerometer 210, a gyroscope 212, a battery 214, and an information element 215. The processor 202 can be configured, among other things, to process data, execute instructions to perform one or more functions, such as the methods disclosed herein, and control the operation of the wireless sensor 102. The data storage device 204 can include one or more memory devices that store data, including without limitation, random access memory (RAM)

and read-only memory (ROM). The wireless transceiver 206 can be configured to use any of a variety of wireless technologies, such as Wi-Fi (802.11x), Bluetooth, ZigBee, cellular telephony, infrared, RFID, satellite transmission, proprietary protocols, combinations of the same, and the like. The components of the wireless sensor 102 can be coupled together by way of a system bus 208, which may represent one or more buses. The battery 214 provides power for the hardware components of the wireless sensor 102 described herein. As illustrated in FIG. 2A, the battery 214 communicates with other components over system bus 208. One skilled in the art will understand that the battery 214 can communicate with one or more of the hardware functional components depicted in FIG. 2A by one or more separate electrical connections. The information element 215 can be a memory storage element that stores, in non-volatile memory, information used to help maintain a standard of quality associated with the wireless sensor 102. Illustratively, the information element 215 can store information regarding whether the sensor 102 has been previously activated and whether the sensor 102 has been previously operational for a prolonged period of time, such as, for example, four hours. The information stored in the information element 215 can be used to help detect improper re-use of the wireless sensor 102.

**[0096]** In some embodiments, the accelerometer 210 is a three-dimensional (3D) accelerometer. The term 3D accelerometer as used herein includes its broad meaning known to a skilled artisan. The accelerometer 210 provides outputs responsive to acceleration of the wireless sensor 102 in three orthogonal axes, sometimes denoted as the “X,” “Y,” and “Z” axes. An accelerometer 210 may measure acceleration that it experiences relative to Earth’s gravity. An accelerometer 210 may provide acceleration information along three axes, and it may provide acceleration information which is the equivalent of inertial acceleration minus local gravitational acceleration. Accelerometers 210 are well known to those skilled in the art. The accelerometer 210 may be a micro-electromechanical system (MEMS), and it may include piezo-resistors, among other forms of implementation. The accelerometer 210 may be a high-impedance charge output or a low-impedance charge output accelerometer 210. In some

embodiments, the accelerometer 210 may be a tri-axis accelerometer, and the output of the accelerometer 210 may include three signals, each of which represents measured acceleration in particular axis. The output of the accelerometer 210 may be 8-bit, 12-bit, or any other appropriate-sized output signal. The outputs of the accelerometer may be in analog or digital form. The accelerometer 210 may be used to determine the position, orientation, and/or motion of the patient to which the wireless sensor 102 is attached.

**[0097]** In some embodiments, the gyroscope 212 is a three-axis digital gyroscope with angle resolution of two degrees and with a sensor drift adjustment capability of one degree. The term three-axis gyroscope as used herein includes its broad meaning known to a skilled artisan. The gyroscope 212 provides outputs responsive to sensed angular velocity of the wireless sensor 102 (as affixed to the patient) in three orthogonal axes corresponding to measurements of pitch, yaw, and roll. A skilled artisan will appreciate that numerous other gyroscopes 212 can be used in the wireless sensor 102 without departing from the scope of the disclosure herein. In certain embodiments, the accelerometer 210 and gyroscope 212 can be integrated into a single hardware component which may be referred to as an inertial measurement unit (IMU). In some embodiments, the IMU can also include an embedded processor that handles, among other things, signal sampling, buffering, sensor calibration, and sensor fusion processing of the sensed inertial data. In other embodiments, the processor 202 can perform these functions. And in still other embodiments, the sensed inertial data are minimally processed by the components of the wireless sensor 102 and transmitted to an external system, such as the patient monitor 106, for further processing, thereby minimizing the complexity, power consumption, and cost of the wireless sensor 102, which may be a single-use, disposable product.

**[0098]** FIG. 2B is a simplified hardware functional block diagram of an embodiment of the disclosed wireless sensor 102 that includes the following optional (as reflected by dotted lines) sensing components: a magnetometer 216 which may also be referred to as a compass, a temperature sensor 218, an acoustic respiration sensor 220, an electrocardiogram (ECG) sensor 222, one or more

oximetry sensors 224, a moisture sensor 226, and an impedance sensor 228. In some embodiments, the magnetometer 216 is a three-dimensional magnetometer that provides information indicative of magnetic fields, including the Earth's magnetic field. While depicted in FIG. 2B as separate functional elements, a skilled artisan will understand that the accelerometer 210, gyroscope 212, and magnetometer 214 can be integrated into a single hardware component such as an inertial measurement unit.

**[0099]** According to an embodiment, a system and method are described herein to calculate three-dimensional position and orientation of an object derived from inputs from three sensors attached to the object: an accelerometer 210 configured to measure linear acceleration along three axes; a gyroscope 212 configured to measure angular velocity around three axes; and a magnetometer 214 configured to measure the strength of a magnetic field (such as the Earth's magnetic field) along three axes. In an embodiment, the three sensors 210, 212, and 214 are attached to the wireless sensor 102 which is affixed to the patient. According to an embodiment, the sensors 210, 212, and 214 are sampled at a rate between approximately 10 Hz and approximately 100 Hz. One skilled in the art will appreciate that the sensors 210, 212, and 214 can be sampled at different rates without deviating from the scope of the present disclosure. The sampled data from the three sensors 210, 212, and 214, which provide nine sensor inputs, are processed to describe the patient's position and orientation in three-dimensional space. In an embodiment, the patient's position and orientation are described in terms of Euler angles as a set of rotations around a set of X-Y-Z axes of the patient.

**[0100]** Also illustrated in FIG. 2B is a temperature sensor 218 which may be used to measure the patient's body core temperature which is a vital sign used by clinicians to monitor and manage patients' conditions. The temperature sensor 218 can include a thermocouple, a temperature-measuring device having two dissimilar conductors or semiconductors that contact each other at one or more spots. A temperature differential is experienced by the different conductors. The thermocouple produces a voltage when the contact spot differs from a reference temperature. Advantageously, thermocouples are self-powered and therefore do not

require an external power source for operation. In an embodiment, the temperature sensor 218 includes a thermistor. A thermistor is a type of resistor whose resistance value varies depending on its temperature. Thermistors typically offer a high degree of precision within a limited temperature range.

**[0101]** The acoustic respiration sensor 220 can be used to sense vibrational motion from the patient's body (*e.g.*, the patient's chest) that are indicative of various physiologic parameters and/or conditions, including without limitation, heart rate, respiration rate, snoring, coughing, choking, wheezing, and respiratory obstruction (*e.g.*, apneic events). The ECG sensor 222 can be used to measure the patient's cardiac activity. According to an embodiment, the ECG sensor 222 includes two electrodes and a single lead. The oximetry sensor(s) 224 can be used to monitor the patient's pulse oximetry, a widely accepted noninvasive procedure for measuring the oxygen saturation level of arterial blood, an indicator of a person's oxygen supply. A typical pulse oximetry system utilizes an optical sensor clipped onto a portion of the patient's body (such as, for example, a fingertip, an ear lobe, a nostril, and the like) to measure the relative volume of oxygenated hemoglobin in pulsatile arterial blood flowing within the portion of the body being sensed. Oxygen saturation (SpO<sub>2</sub>), pulse rate, a plethysmograph waveform, perfusion index (PI), pleth variability index (PVI), methemoglobin (MetHb), carboxyhemoglobin (CoHb), total hemoglobin (tHb), glucose, and/or otherwise can be measured and monitored using the oximetry sensor(s) 224. The moisture sensor 226 can be used to determine a moisture content of the patient's skin which is a relevant clinical factor in assessing the patient's risk of forming a pressure ulcer. The impedance sensor 228 can be used to track fluid levels of the patient. For example, the impedance sensor 228 can monitor and detect edema, heart failure progression, and sepsis in the patient.

**[0102]** FIG. 3A is a schematic exploded perspective view of an embodiment of the disclosed wireless sensor 102 including a bottom base 310, a removable battery isolator 320, a mounting frame 330, a circuit board 340, a housing 350, and a top base 360. The bottom base 310 is a substrate having a top surface on which various components of the wireless sensor 102 are positioned,

and a bottom surface that is used to affix the wireless sensor 102 to the patient's body. The bottom base 310 and top base 360 can be made of medical-grade foam material such as white polyethylene, polyurethane, or reticulated polyurethane foams, to name a few. As illustrated in the embodiment illustrated in Fig. 3A, the bottom base 310 and the top base 360 are each in a substantially oval shape, with a thickness of approximately 1 mm. The top base 360 includes a cut-out 362 through which the housing 350 fits during assembly. Of course, a skilled artisan will understand that there are numerous sizes and shapes suitable for the top and bottom bases 310 and 360 that can be employed without departing from the scope of the present disclosure. The bottom surface of the bottom base 310 is coated with a high tack, medical-grade adhesive, which when applied to the patient's skin, is suitable for long-term monitoring, such as, for example two days or longer. Portions of the top surface of the bottom base 310 are also coated with a medical-grade adhesive, as the bottom base 310 and the top base 360 are adhered together during assembly of the wireless sensor 102.

**[0103]** The removable battery isolator 320 is a flexible strip made of an electrically insulating material that serves to block electrical communication between the battery 214 and an electrical contact (not shown) on the circuit board 340. The battery isolator 320 is used to preserve battery power until the wireless sensor 102 is ready for use. The battery isolator 320 blocks electrical connection between the battery 214 and the circuit board 340 until the battery isolator 320 is removed from the wireless sensor 102. The battery isolator 320 can be made of any material that possesses adequate flexibility to be slidably removed from its initial position and adequate dielectric properties so as to electrically isolate the battery from the circuit board 340. For example, the battery isolator can be made of plastic, polymer film, paper, foam, combinations of such materials, or the like. The battery isolator 320 includes a pull tab 322 that extends through a slot 352 of the housing 350 when the wireless sensor 102 is assembled. The pull tab 322 can be textured to provide a frictional surface to aid in gripping and sliding the pull tab 322 out of its original assembled position. Once the battery isolator 320 is removed the battery 214 makes

an electrical connection with the battery contact to energize the electronic components of the wireless sensor 102.

**[0104]** The mounting frame 330 is a structural support element that helps secure the battery 214 to the circuit board 340. The mounting frame 340 has wings 342 that, when assembled are slid between battery contacts 342 and the battery 214. Additionally, the mounting frame 330 serves to provide rigid structure between the circuit board 340 and the bottom base 310. According to some embodiments that include an acoustic respiratory sensor, the rigid structure transmits vibrational motion (vibrations) emanating from the patient (such as, for example, vibrational motions related to respiration, heartbeat, snoring, coughing, choking, wheezing, respiratory obstruction, and the like) to the accelerometer 210 positioned on the circuit board 340.

**[0105]** The circuit board 340, which may also be referred to herein as a substrate layer 340 and a circuit layer 340, mechanically supports and electrically connects electrical components to perform many of the functions of the wireless sensor 102. The circuit board 340 includes conduction tracks and connection pads. Such electrical components can include without limitation, the processor 202, the storage device 204, the wireless transceiver 206, the accelerometer 210, the gyroscope 212, the magnetometer 214, the temperature sensor 218, the acoustic respiration sensor 220, the ECG sensor 222, the oximetry sensor 224, the moisture sensor 226, and the impedance sensor 228. In an embodiment, the circuit board 340 is double sided having electronic components mounted on a top side and a battery contact (not shown) on a bottom side. Of course a skilled artisan will recognize other possibilities for mounting and interconnecting the electrical and electronic components of the wireless sensor 102.

**[0106]** As illustrated in FIG. 3A, a battery holder 342 is attached to two sides of the top portion circuit board 340 and extends (forming a support structure) under the bottom side of the circuit board 340 to hold the battery 214 in position relative to the circuit board 340. The battery holder 342 is made of electrically conductive material. In some embodiments, the battery 214 is a coin cell battery having a cathode on the top side and an anode on the bottom side. Electrical

connection between the anode of the battery 214 and the circuit board 340 is made by way of the battery holder which is in electrical contact with the anode of the battery 214 and the circuit board 340. The cathode of the battery 214 is positioned to touch a battery contact (not shown) on the bottom side of the circuit board 340. In some embodiments, the battery contact includes a spring arm that applies force on the battery contact to ensure that contact is made between the anode of the battery 214 and the battery contact. During assembly and prior to use, the battery isolator 320 is inserted between the anode of the battery 214 and the battery connector to block electrical contact.

**[0107]** The housing 350 is a structural component that serves to contain and protect the components of the wireless sensor 102. The housing 350 can be made of any material that is capable of adequately protecting the electronic components of the wireless sensor 102. Examples of such materials include without limitation thermoplastics and thermosetting polymers. The housing 350 includes a slot 352 through which the battery isolator 320 is inserted during assembly. The housing 350 also includes a rim 354 that extends around the outer surface of the housing 350. The rim 354 is used to secure the housing 350 in position relative to the bottom base 310 and the top base 360 when the wireless sensor 102 is assembled.

**[0108]** Assembly of the wireless sensor 102 is as follows: The circuit board 340 and battery holder 342 holding the battery 214 are placed into the housing 350. The wings 332 of the mounting frame 330 are inserted in between the battery 214 and the battery holder 342, so as to align the mounting frame 330 with the circuit board 340. The battery isolator 320 is then positioned between the battery contact and the battery 214. The pull tab 322 of the battery isolator 320 is then fed through the slot 352 in the housing 350. The top base 360 is then positioned over the housing 350, which now houses the assembled circuit board 340, battery holder 342, battery 214, mounting frame 330, and battery isolator 320, using the cut-out 362 for alignment. The rim 354 of the housing 350 adheres to the bottom surface of the top base 360, which is coated with high tack, medical-grade adhesive. The partial assembly, which now includes the top base 360, the housing 350, the circuit

board 340, the battery holder 342, the battery 214, the mounting frame 330, and the battery isolator 320, is positioned centrally onto the top surface of the bottom base 310, aligning the edges of the base top 360 with the edges of the base bottom 310. In some embodiments, a coupon (or die cutting tool) is used to cut away excess portions of the now combined top and bottom bases 360 and 310 to form a final shape of the wireless sensor 102. The bottom surface of the bottom base 310 is then coated with a high tack, medical-grade adhesive, and a release liner (not shown) is placed on the bottom surface of the bottom base 3310 to protect the adhesive until it is time for use.

**[0109]** A schematic perspective view of the assembled wireless sensor 102 is illustrated in FIG. 3B. Also illustrated in FIG. 3B is a button/switch 324 located on a top portion of the housing 350. The button/switch 324 can be used to change modes of the wireless sensor 102. For example, in some embodiments, pressing and holding the button/switch 324 can cause the wireless sensor 102 to switch into a pairing mode of operation. The pairing mode is used to associate the wireless sensor 102 with a patient monitor 106 or with an extender/repeater 107. FIG. 3C provides a schematic side view of an embodiment of the assembled wireless sensor 102 with cross-section line A-A identified.

**[0110]** Referring now to FIGS. 4A and 4B, an embodiment of the wireless sensor 102 is disclosed which includes a temperature sensor 218. FIG. 4A is a schematic cross-sectional view, sectioned along line A-A of FIG. 3C, illustrating an assembled embodiment of the disclosed wireless sensor 102 which includes the temperature sensor 218. For easier visibility, the battery isolator 320 and the battery holder 342 are not illustrated. FIG. 4B is a schematic bottom view of the embodiment of the disclosed wireless sensor of FIG. 4A. The bottom surface of the bottom base 310 is illustrated. Also illustrated in phantom (*i.e.*, dotted lines) is the outline of cut-out 362 which also indicates the position of the housing 350 in relation to the bottom surface of the bottom base 310.

**[0111]** As explained above with respect to the assembly of the wireless sensor 102, the top surface of the bottom base 310 is in contact with and adhered to the bottom surface of the top base 360. The rim 354 of the housing 350 is

sandwiched between the two bases 310 and 360 to secure the housing 350. The housing 350 also protrudes through the cut-out 362 of the top base 360. Within the housing, the battery 214 and the mounting frame 330 are adjacent the top surface of the bottom base 310.

**[0112]** As illustrated in FIG. 4A, the temperature sensor 218 is mounted on the circuit board 340. To perform its temperature sensing function, the temperature sensor 218 is in thermal contact with the patient's skin. To achieve this, structure to transmit thermal energy from the patient's body to the temperature sensor 218 is provided. In particular, inputs to the temperature sensor 218 are thermally connected to multiple through-hole vias 410 located in the circuit board 340. A through-hole via is a small vertical opening or pathway in the circuit board 340 through which thermally and/or electrically conductive material can be placed, thereby permitting transmission of thermal and/or electrical energy from one side of the circuit board 340 to the other side. Under the through-hole vias 410 is an aperture or opening 404 which extends through the mounting frame 330 (to form a mounting frame aperture) and through the bottom base 310 of the wireless sensor 102. The aperture 404 provides access from the temperature sensor 218 to the patient's skin when the wireless sensor 102 is worn by the patient. The aperture 404 and the through-hole vias 410 are filled with thermally conductive material 402. Thermally conductive materials are well known in the art and can include, by way of non-limiting example, thermally conductive elastomers, polymers, and resins, to name a few. Illustratively, in operation, the wireless sensor 102 is affixed to the patient's skin. The thermally conductive material 402, exposed to the patient's skin, transmits thermal energy from the patient's body through the aperture 404 and the through-hole vias 410 to arrive at the inputs to the temperature sensor 218.

**[0113]** Advantageously, the disclosed wireless sensor 102 can measure the patient's body core temperature (an established and useful vital sign) with the temperature sensor 218 using a technique by which deep tissue temperature can be measured from the skin surface. In the human body, there is a natural heat flux between the body core and the skin surface because the body core temperature is typically at a higher temperature than that of the skin surface. Thus heat flows from

the body core to the skin. By insulating the skin surface at and around the point at which the skin temperature is measured -- thereby blocking heat from escaping -- the temperature gradient between the body core and the skin surface will decrease. The skin temperature, under the insulated area will rise until it reaches equilibrium with the warmest region (*i.e.*, the body core) under the insulation, thereby approaching the body core temperature. When equilibrium is reached, the skin temperature is equal to the core body temperature. Advantageously, the bottom base 310 and top base 360 of the wireless sensor 102, which are in contact with the patient's skin around the temperature sensor 218, possess thermal insulation properties. Illustratively, by way of non-limiting example, the bottom base 310 and top base 360 can be made thermally insulating materials including polyurethane foam, polystyrene foam, neoprene foam, neoprene rubber, polyester (Mylar), polytetrafluoroethylene (PTFE), silicone foam, silicone rubber, or the like. Accordingly, the temperature sensor 218 can measure the patient's body core temperature.

**[0114]** FIG. 4C is a schematic exploded perspective view of the embodiment of the disclosed wireless sensor of FIGS. 4A and 4B. As shown, the temperature sensor 218 is mounted on the top surface of the circuit board 340. The aperture 404 extends through the mounting frame 330 and the bottom base 310 and is aligned vertically with the through-hole vias 410 (not shown in FIG. 4C) and the temperature sensor 218. The aperture 404 and the through-hole vias 410 are filled with thermally conductive material 402. Thus the disclosed structure provides thermal connectivity between the patient's skin and the temperature sensor 218.

**[0115]** Referring now to FIGS. 5A and 5B, an embodiment of the wireless sensor 102 is disclosed which includes an acoustic respiration sensor 220. FIG. 5A is a schematic cross-sectional view, sectioned along line A-A of FIG. 3C, illustrating an assembled embodiment of the disclosed wireless sensor 102 which includes the acoustic respiration sensor 220. For easier visibility, the battery isolator 320 and the battery holder 342 are not illustrated. FIG. 5B is a schematic bottom view of the embodiment of the disclosed wireless sensor of FIG. 5A. The bottom surface of the bottom base 310 is illustrated. Also illustrated in phantom (*i.e.*, dotted lines) is the

outline of cut-out 362 which indicates the position of the housing 350 in relation to the bottom surface of the bottom base 310.

**[0116]** As illustrated in FIG. 5A, the acoustic respiration sensor 220 is mounted underneath the battery 214. Operationally, the acoustic respiration sensor 220 detects vibratory motion emanating from the patient's body (*e.g.*, the patient's chest) and mechanically transmits the detected vibratory motion to the accelerometer 210. The accelerometer 210 senses the mechanically transmitted vibratory motion. The signal collected by accelerometer 210 can be processed to extract the vibratory motion from other sensed acceleration signals. Examples of such vibratory motion can include, without limitation, heart beats, respiration activity, coughing, wheezing, snoring, choking, and respiratory obstruction (*e.g.*, apneic events). To mechanically transmit the sensed vibratory motion effectively, the acoustic respiration sensor 220 is in rigid structural contact with the accelerometer 210. To achieve this, the acoustic respiration sensor 220 is mounted to the bottom side of the battery 214. In particular, the acoustic respiration sensor 220 includes a rim 221 that is sandwiched between the bottom surface of the battery 214 and the bottom base 310. Accordingly, the rim 221 serves to rigidly secure the acoustic respiration sensor 220 to the bottom surface of the battery 214.

**[0117]** As illustrated in FIG. 5A, the acoustic respiration sensor 220 protrudes through an aperture or opening 502 in the bottom base 310, beyond the plane created by the bottom base 310. This is to ensure that the acoustic respiration sensor 220 is in direct contact with the patient's body (*e.g.*, chest) so as to sense the vibrational motion emanating from the patient. Within the acoustic respiration sensor 220 is a flexible wire or other such structure under slight tension such that when the wire is exposed to vibratory motion, it will vibrate in a manner that is proportional to the sensed vibratory motion with respect to both frequency and magnitude of the sensed vibratory motion. The acoustic respiration sensor 220 is configured to transmit the sensed vibratory motion through rigid structures of the wireless sensor 102 such that the transmitted vibratory motion is sensed by the accelerometer 210. The rigid structure includes the battery 214 and the circuit board 340.

**[0118]** FIG. 5C is a schematic exploded perspective view of the embodiment of the disclosed wireless sensor of FIGS. 5A-B. As shown, the accelerometer 210 is mounted on the top surface of the circuit board 340 over the battery 214 which is secured underneath the circuit board 340. The acoustic respiration sensor 220 (not shown in FIG. 5C) fits between the battery 214 and the bottom base 310. The aperture 502 extends through the bottom base 310 and is aligned vertically with battery 214 such that the acoustic respiration sensor 220 is secured to rigid structure of the wireless sensor 102. Thus the disclosed structure provides the ability for the acoustic respiration sensor 220 to mechanically transmit vibratory motion from the patient's chest to the accelerometer 210.

**[0119]** FIGS. 6A-C illustrate an embodiment of the disclosed wireless sensor 102 which includes a temperature sensor 218 and an acoustic respiration sensor 220. FIG. 6A is a schematic cross-sectional view, sectioned along line A-A of FIG. 3C, illustrating an assembled embodiment of the disclosed wireless sensor 102 which includes the temperature sensor 218 and acoustic respiration sensor 220. For easier visibility, the battery isolator 320 and the battery holder 342 are not illustrated. FIG. 6B is a schematic bottom view of the embodiment of the disclosed wireless sensor of FIG. 6A. FIG. 6C is a schematic exploded perspective view of the embodiment of the disclosed wireless sensor 102 of FIGS. 6A and 6B.

**[0120]** Structurally, the embodiment depicted in FIGS. 6A-C is a combination of the embodiments depicted in FIGS. 4A-C and 5A-C. As illustrated in FIGS. 6A-B, the temperature sensor 218 is mounted on the circuit board 340. As previously described, inputs to the temperature sensor 218 are thermally coupled to multiple through-hole vias 410 located in the circuit board 340. Under the through-hole vias 410 is an aperture 404 which extends through the mounting frame 330 and through the bottom base 310 of the wireless sensor 102. The aperture 404 provides access from the temperature sensor 218 to the patient's skin when the wireless sensor 102 is worn by the patient. The aperture 404 and the through-hole vias 410 are filled with thermally conductive material 402. In operation, the wireless sensor 102 is affixed to the patient's skin. The thermally conductive material 402, exposed to the patient's skin, transmits thermal energy from the patient's body through the

aperture 404 and the through-hole vias 410 to arrive at the inputs to the temperature sensor 218.

**[0121]** Also as illustrated in FIGS. 6A-B, the acoustic respiration sensor 220 is mounted underneath the battery 214. In particular, the acoustic respiration sensor 220 includes rim 221 that is sandwiched between the bottom surface of the battery 214 and the bottom base 310. Accordingly, the rim 221 serves to rigidly secure the acoustic respiration sensor 220 to the bottom surface of the battery 214. The acoustic respiration sensor 220 protrudes through the aperture 502 in the bottom base 310, beyond the plane created by the bottom base 310. The acoustic respiration sensor 220 is configured to transmit vibratory motion sensed from the patient (*e.g.*, from the patient's chest) through rigid structures of the wireless sensor 102 such that the transmitted vibratory motion is sensed by the accelerometer 210. The rigid structure includes the battery 214 and the circuit board 340.

**[0122]** FIG. 6C is a schematic exploded perspective view of the embodiment of the disclosed wireless sensor of FIGS. 6A and 6B. As shown, the temperature sensor 218 is mounted on the top surface of the circuit board 340. The aperture 404 extends through the mounting frame 330 and the bottom base 310 and is aligned vertically with the through-hole vias 410 (not shown in FIG. 4C) and the temperature sensor 218. The aperture 404 and the through-hole vias 410 are filled with thermally conductive material 402. Additionally, the accelerometer 210 is mounted on the top surface of the circuit board 340 over the battery 214 which is secured underneath the circuit board 340. The acoustic respiration sensor 220 (not shown in FIG. 6C) fits between the battery 214 and the bottom base 310. In some embodiments, the acoustic respiration sensor 220 abuts against the mounting frame 330 in a manner such that the acoustic respiration sensor 220, the mounting frame 330, the battery 214 and the circuit board 340 form a rigid structure capable of mechanically transmitting vibratory motion sensed by the acoustic respiration sensor 220 to the accelerometer 210 mounted on the circuit board 340. The aperture 502 extends through the bottom base 310 and is aligned vertically with battery 214 such that the acoustic respiration sensor 220 is secured to rigid structure of the wireless sensor 102. Thus the disclosed embodiment provides thermal connectivity between

the patient's skin and the temperature sensor 218 and the ability for the acoustic respiration sensor 220 to mechanically transmit vibratory motion from the patient's chest to the accelerometer 210.

**[0123]** Advantageously, the embodiment disclosed in FIGS. 6A-C is capable of providing, among other things, three vital signs: body core temperature, pulse rate, and respiration rate. Vital signs are measurements of the body's most basic functions and are used routinely by healthcare providers to assess and monitor a patient's status. The patient's body core temperature can be provided by the temperature sensor 218. The patient's pulse rate and respiration rate can be provided by the acoustic respiration sensor 220 in combination with the accelerometer 210.

**[0124]** Referring to FIGS. 7A-F, an embodiment of the disclosed wireless sensor 102 is shown which includes an electrocardiogram (ECG) sensor 222. Chip-scale and/or component-scale ECG sensors, suitable for mounting on circuit boards are known in the art. Illustratively, by way of non-limiting example, solid state ECG sensors are offered by Texas Instruments and by Plessy Semiconductors Ltd., to name a few. FIG. 7A is a perspective view of the embodiment of the disclosed patient-worn wireless sensor 102 having an ECG sensor 222 including an ECG lead 706 that extends from the housing 350. The wireless sensor 102 is adhered to the patient's chest, for example, over the manubrium as illustrated in FIG. 7A. The ECG lead 706 extends from the housing 350 of the wireless sensor 102 to a location on the patient's chest suitable to sense electrical signals generated by the patient's heart. The ECG lead 706 is in electrical communication with an ECG electrode 707 which, in operation, is adhered to the patient's chest. In certain embodiments, the ECG electrode 707 includes conducting gel embedded in the middle of a self-adhesive pad. The ECG electrode 707 senses electrical signals from the patient's chest and transmits the sensed signals, via the lead 706, to the ECG sensor 222. The electrode 707 adheres to the patient's skin and senses electrical signals therefrom. A skilled artisan will appreciate that many structures, forms, and formats of ECG electrodes are well known in the art and can be used to implement the ECG electrode 707.

**[0125]** As illustrated in FIG. 7A, the ECG lead 706 extends to the left side of the patient's chest to a position across the heart from where the wireless sensor 102 is located. Another ECG electrode 702 (described below), also in contact with the patient's skin, is formed beneath the housing 350 at the bottom base 310. Thus, a vector is formed between the ECG lead electrode 707 and the ECG electrode 702 by which the electrical signals of the patient's heart can be sensed. Illustratively, when the electrodes 702 and 707 are positioned as depicted in FIG. 7A, the ECG sensor 222 can sense ECG signals that are similar in morphology to ECG signals detected on Lead I or Lead II of a standard 12-lead ECG.

**[0126]** FIG. 7B is a schematic assembled perspective view of the embodiment of the disclosed wireless sensor 102 of FIG. 7A. The ECG lead 706 is connected to the ECG sensor 222 (shown in FIG. 7D) which is mounted on the circuit board 340. As illustrated in FIG. 7B, the ECG lead extends through the housing 350 to a lockable retractable reel 708 that stores the ECG lead 706 in a coil when not in use. The ECG lead 706 can be extended from the reel 708 and locked in the desired position, thereby enabling placement of the ECG lead electrode 707 at a desired location on the patient's chest. In some embodiments, the locking mechanism is engaged and disengaged by applying a pulling force on the lead 706. Various forms and versions of lockable retractable reels are well known in the art and may be used to implement the reel 708.

**[0127]** FIG. 7C provides a schematic side view of the embodiment of the assembled wireless sensor 102 of FIGS. 7A and 7B with cross-section line B-B identified. FIG. 7D is a cross-sectional view of the embodiment of FIGS. 7A-C sectioned along line B-B. As illustrated in FIG. 7D, the ECG sensor 222 is mounted on the circuit board 340. To perform its sensing function, the ECG sensor 222 is in electrical contact with at least two points on the patient's skin. Two electrodes 702 and 707 are provided to achieve this purpose. While ECG electrode 707 has been described above, description of the ECG electrode 702 follows herewith.

**[0128]** ECG electrode 702 is located within the bottom base 310 of the wireless sensor 102. An input to the ECG sensor 222 is electrically connected to multiple through-hole vias 710 located in the circuit board 340. As previously

described, through-hole vias are small vertical openings, or pathways, in the circuit board 340 through which electrically conductive material can be placed, thereby permitting transmission of electrical signals from one side of the circuit board 340 to the other side. Under the through-hole vias 710 is an aperture or opening 704 which extends through the mounting frame 330 (to form a mounting frame aperture) and through the bottom base 310 of the wireless sensor 102. The aperture 704 provides access from the ECG sensor 222 to the patient's skin when the wireless sensor 102 is worn by the patient. The aperture 704 and the through-hole vias 710 are filled with electrically conductive material to form the ECG electrode 702. Electrically conductive materials are well known in the art and can include, by way of non-limiting example, electrically conductive silicones, elastomers, polymers, epoxies, and resins, to name a few. In operation, the wireless sensor 102 is affixed to the patient's skin and the ECG electrode 702, exposed to the patient's skin, senses and transmits electrical signals from the patient's skin surface through the aperture 704 and the through-hole vias 710 to arrive at an input to the ECG sensor 222.

**[0129]** FIG. 7E is a schematic bottom view of the embodiment of the disclosed wireless sensor of FIGS. 7A-D. The bottom surface of the bottom base 310 is illustrated. Also illustrated in phantom (*i.e.*, dotted lines) are the outline of cut-out 362 which also indicates the position of the housing 350 in relation to the bottom surface of the bottom base 310, and the lockable retractable reel 708. The ECG electrode 702 is also illustrated as it is positioned to make contact with the patient's skin. In some embodiments, the ECG electrode may be coated with a conducting gel to improve the electrode-to-skin interface.

**[0130]** FIG. 7F is a schematic exploded perspective view of the embodiment of the disclosed wireless sensor of FIGS. 7A-7E. As shown, the ECG sensor 222 is mounted on the top surface of the circuit board 340. The aperture 704 extends through the mounting frame 330 and the bottom base 310 and is aligned vertically with the through-hole vias 710 (not shown in FIG. 7F) and the ECG sensor 222. The aperture 704 and the through-hole vias 710 are filled with electrically conductive material to form electrode 702. Thus the disclosed structure provides electrical connectivity between the patient's skin and the ECG sensor 222.

**[0131]** FIG. 8A is a schematic exploded perspective view of an embodiment of the disclosed wireless sensor having a temperature sensor 218, an acoustic respiration sensor 220, and an ECG sensor 222. FIG. 8B is a schematic bottom view of the disclosed wireless sensor of FIG. 8A. Structurally, the embodiment depicted in FIGS. 8A-B is a combination of the embodiments depicted in FIGS. 4A-C and 5A-C and 7A-F. As illustrated in FIGS. 8A-B, the temperature sensor 218 is mounted on the circuit board 340. As previously described, inputs to the temperature sensor 218 are thermally coupled to multiple through-hole vias 410 located in the circuit board 340. Under the through-hole vias 410 is an aperture 404 which extends through the mounting frame 330 and through the bottom base 310 of the wireless sensor 102. The aperture 404 provides access from the temperature sensor 218 to the patient's skin when the wireless sensor 102 is worn by the patient. The aperture 404 and the through-hole vias 410 are filled with thermally conductive material 402.

**[0132]** The acoustic respiration sensor 220 is mounted underneath the battery 214, held in place by rim 221 that is sandwiched between the bottom surface of the battery 214 and the bottom base 310. Accordingly, the rim 221 serves to rigidly secure the acoustic respiration sensor 220 to the bottom surface of the battery 214. The acoustic respiration sensor 220 protrudes through the aperture 502 in the bottom base 310, beyond the plane created by the bottom base 310. The acoustic respiration sensor 220 transmits vibratory motion sensed from the patient (*e.g.*, from the patient's chest) through rigid structures of the wireless sensor 102 such that the transmitted vibratory motion is sensed by the accelerometer 210. The rigid structure through which the vibratory motion is transmitted includes the battery 214 and the circuit board 340.

**[0133]** The ECG electrode 702 is located within the bottom base 310 of the wireless sensor 102. An input to the ECG sensor 222 is electrically coupled to multiple through-hole vias 710 located in the circuit board 340. Under the through-hole vias 710 is an aperture or opening 704 which extends through the mounting frame 330 and through the bottom base 310 of the wireless sensor 102. The aperture 704 provides access from the ECG sensor 222 to the patient's skin

when the wireless sensor 102 is worn by the patient. The aperture 704 and the through-hole vias 710 are filled with electrically conductive material to form the ECG electrode 702.

**[0134]** In operation, the wireless sensor 102 is affixed to the patient's skin. The thermally conductive material 402, exposed to the patient's skin, transmits thermal energy from the patient's body through the aperture 404 and the through-hole vias 410 to arrive at the inputs to the temperature sensor 218. The acoustic respiratory sensor 220 senses vibratory motion from the patient and mechanically transmits the vibratory motion to the accelerometer 210 mounted on the circuit board. And the ECG electrodes 702 and 707, exposed to the patient's skin, sense and transmit electrical signals from the patient's skin surface to arrive at inputs to the ECG sensor 222.

**[0135]** FIG. 8B is a schematic bottom view of the embodiment of the disclosed wireless sensor of FIGS. 8A. The bottom surface of the bottom base 310 is illustrated. Also illustrated in phantom (*i.e.*, dotted lines) are the outline of cut-out 362 and the lockable retractable reel 708. Three sensor access points are shown in FIG 8B. The thermally conductive material 402 provides a pathway for thermal energy to be transmitted from the patient's skin the temperature sensor 218 mounted on the circuit board 340. The acoustic respiration sensor 220 is in direct contact with the patient's skin and in rigid structural contact with the accelerometer 210 so as to mechanically transmit sensed vibratory motion emanating from the patient to the accelerometer 210 mounted on the circuit board 340. And the ECG electrode 702 provides a pathway for electrical signals to be transmitted from the patient's skin to the ECG sensor 220 mounted on the circuit board 340.

**[0136]** As discussed above, embodiments of the wireless sensor 102 can include an accelerometer 210, an acoustic respiration sensor 220, a thermal sensor 218, and/or an ECG sensor 220 including an ECG electrode 707 among other elements. According to various embodiments described herein, the wireless sensor 102 can contact a patient's skin to perform various monitoring and sensing functions. For example, the wireless sensor 102 can be affixed to the patient's skin

such that the accelerometer 210, the acoustic respiration sensor 220, the thermal sensor 218, and/or ECG sensor 222 can be exposed to the patient's skin.

**[0137]** While embodiments described herein may be positioned on the patient's body, such as on the patient's chest, for example, the wireless sensor 102 can be affixed to or otherwise placed on various portions of the patient's body, such as on the patient's back as illustrated in FIGS. 17A and 17B. The wireless sensor 102 can receive and/or measure signals indicating a temperature, a vibration, a movement, or a heartbeat, among other parameters.

**[0138]** In particular, the wireless sensor 102 may be placed between a patient's shoulder blades on the patient's back, or other portions of the patient's back. In some configurations, the wireless sensor 102 may not be associated with the mattress. For example, the wireless sensor 102, including the accelerometer 210, for example, may be placed on the patient at a location where the patient's loose tissue does not typically significantly alter the accuracy of a reading, such as on the patient's back. The wireless sensor 102 may be placed closer to one shoulder blade than the other. The wireless sensor 102 may be placed at approximately a center between the shoulder blades of the patient. In some configurations, the wireless sensor 102 can be affixed to any position on the patient's back between the patient's shoulder blades, or any other position on the patient's back, such as the patient's lower back. In some examples, only the accelerometer is exposed to the patient's skin and placed on the patient's back. In some configurations, the wireless sensor 102 can be affixed to another portion of the patient's body.

**[0139]** In many instances, placement of the sensor 102 on the patient's back having little loose tissue may advantageously increase the accuracy of measurements measured by the wireless sensor 102. In some embodiments, placement of the sensor 102 on the patient's back having little loose tissue may advantageously increase the accuracy of measurements measured by at least an accelerometer of the wireless sensor 102. In some embodiments, the patient's back, such as between the shoulder blades, can provide a flat surface upon which the sensor 102 can be positioned.

**[0140]** In certain patients, such as patients having a larger chest or loose tissue on the chest, a wireless sensor 102, including an accelerometer, may provide false readings when the patient moves. In certain such instances, the wireless sensor 102 can provide false readings or measurements even without a significant change in position or orientation or without significant movement of the patient. For example, when the wireless sensor 102 is placed on a patient or portion of a patient's body having a large amount of loose tissue, such as the chest in some patients, even an insignificant change in orientation or position by the patient can cause the wireless sensor 102 to provide a false reading. The false reading may result from a movement or rotation of the wireless sensor 102 or accelerometer on the loose tissue even if the patient does not turn or slightly turns, including when the patient's skin folds or moves in a different direction from the patient's body. In some instances, the false reading can occur as the patient's skin (e.g., loose tissue) (or other portion of the body where the wireless sensor and/or accelerometer is affixed) folds or moves a greater, lesser, or different amount than the remainder of the patient's body. Accordingly, by placing the wireless sensor 102, including the accelerometer 210 in some examples, on the patient's back, the wireless sensor 102 may provide more accurate readings. Such configurations can desirably more accurately measure various parameters such as when the patient is sleeping.

**[0141]** Though numerous sizes and shapes of the wireless sensor 102 and components of the wireless sensor 102 are described herein, the wireless sensor 102 may be shaped and sized to advantageously be positioned on the patient's back and cause minimal discomfort to the patient. For example, the wireless sensor 102 may be shaped and sized such that the sensor 102 is sufficiently thin such that the wireless sensor 102 does not cause any or causes only minimal discomfort to the patient when the wireless sensor 102 is placed on the patient's back. In some embodiments, the form factor of the wireless sensor 102 may be smaller than typical sensors. In some configurations, the sensor 102 placed on a portion of the patient's back (e.g., between the shoulder blades), which can be less sensitive than other regions of the patient's body, can cause minimal or no discomfort to the patient. In some embodiments, the patient cannot feel or minimally

feel the sensor 102 when the sensor 102 is positioned on at least a portion of the patient's back, such as between the patient's shoulder blades.

**[0142]** In some scenarios, it may be desirable to pair, or associate, the wireless sensor 102 with the bedside patient monitor 106 to avoid interference from other wireless devices and/or to associate patient-specific information (stored, for example, on the patient monitor 106) with the sensor data that is being collected and transmitted by the wireless sensor 102. Illustratively, such patient-specific information can include, by way of non-limiting example, the patient's name, age, gender, weight, identification number (*e.g.*, social security number, insurance number, hospital identification number, or the like), admission date, length of stay, physician's name and contact information, diagnoses, type of treatment, perfusion rate, hydration, nutrition, pressure ulcer formation risk assessments, patient turn protocol instructions, treatment plans, lab results, health score assessments, and the like. One skilled in the art will appreciate that numerous types of patient-specific information can be associated with the described patient-worn sensor without departing from the scope of the present disclosure. Additionally, pairing the wireless sensor 102 with the patient monitor 106 can be performed to provide data security and to protect patient confidentiality. Some wireless systems require the care provider to program the wireless sensor 102 to communicate with the correct patient monitor 106. Other wireless systems require a separate token or encryption key and several steps to pair the wireless device 102 with the correct bedside patient monitors 106. Some systems require the token to be connected to the bedside patient monitor 106, then connected to the wireless device 102, and then reconnected to the bedside patient monitor 106. In certain scenarios, it may be desirable to share wireless communication information between a wireless sensor 102 and a bedside patient monitor 106 without a separate token or encryption key. For security purposes, it may be desirable to use security tokens to ensure that the correct bedside patient monitor 106 receives the correct wirelessly transmitted data. Security tokens prevent the bedside patient monitor 106 from accessing the transmitted data unless the wireless sensor 102 and bedside patient monitor 106

share the same password. The password may be a word, passphrase, or an array of randomly chosen bytes.

**[0143]** FIG. 9 illustrates an exemplary method of associating a wireless sensor 102 with a patient monitor 106, which may be referred to as "pairing." At block 902 the wireless sensor 102 is set to operate in a pairing mode. In an embodiment, a user initiates the pairing mode of operation for the wireless sensor 102. This may include powering on the wireless sensor 102, switching the wireless sensor 102 to a special pairing state, and/or the like. For example, in certain embodiments, the wireless sensor 102 may include a battery isolator 320 which, when removed, activates the wireless sensor 102. Upon activation, the default mode of operation is the pairing mode. In some embodiments, the wireless sensor 102 may have a button/switch 324 that can be used to activate the wireless sensor 102 and place it in the pairing mode of operation. For example, a depressible button/switch 324 can be located on the top portion of the housing 350. When the button/switch 324 is depressed and continuously held down, the wireless sensor 102 enters into the pairing mode of operation and remains in the pairing mode of operation for as long as the button/switch 324 is depressed.

**[0144]** As reflected at block 904, the wireless sensor 102 transmits a pairing signal indicating that it is ready to pair, or associate, with a patient monitor 106. According to some embodiments, the wireless transceiver 206 of the wireless sensor 102 is configured to emit a low-power pairing signal having a limited pairing signal transmission range. The limited pairing signal transmission range helps to prevent unintended or incidental association of the wireless sensor 102 with a patient monitor 106 that might be nearby but which is not intended to be paired with the wireless sensor 102. Such circumstances can occur in hospitals, healthcare facilities, nursing homes, and the like where patients, sensors 102 patient monitors 106 are located in close physical proximity to one another. In certain embodiments, the low-power pairing signal has a pairing signal transmission range of up to approximately three inches. In other embodiments, the low-power pairing signal has a pairing signal transmission range of up to approximately six inches. In other embodiments, the low-power pairing signal has a pairing signal transmission range

of up to approximately one foot (*i.e.*, twelve inches). A skilled artisan will recognize that other ranges can be used for the pairing signal transmission range.

**[0145]** Next, at block 906, the patient monitor 106, when within the pairing signal transmission range, receives the pairing signal from the wireless sensor 102. Upon detection of the pairing signal, the patient monitor 106, at block 908, associates with the wireless sensor 102 thereby configuring the wireless sensor 102 and patient monitor 106 to communicate with each other. Once the pairing is completed, the patient monitor 106 transmits a confirmation signal confirming that the patient-worn sensor 102 is associated with the patient monitor 106, thereby indicating that the pairing process has been successfully completed, as reflected in block 910. At block 912, the wireless sensor 102 receives the confirmation signal. And at block 914, the wireless sensor 102 exits the pairing mode of operation and enters into a patient parameter sensing mode of operation. In the patient parameter sensing mode of operation, the patient-worn sensor 102 transmits a patient parameter sensing signal having a patient parameter sensing signal transmission range. The wireless sensor 102 increases the power of the patient parameter sensing signal transmission range to a standard operating range, such as for example, approximately three meters. In some embodiments, the patient parameter sensing signal transmission range is approximately ten feet. In some embodiments, the patient parameter sensing signal transmission range is approximately thirty feet. In certain embodiments, the pairing signal transmission range is between approximately three and twelve inches, while the patient parameter sensing signal transmission range is approximately ten feet. In such embodiments, there is at least an order of magnitude difference between the pairing signal transmission range and the patient parameter sensing signal transmission range. Thus, the pairing signal transmission range is substantially less than the patient parameter sensing transmission range. Once the wireless sensor 102 enters into the patient parameter sensing mode of operation, the wireless sensor 102 is then in condition to be placed on the patient to perform sensing and monitoring functions.

**[0146]** In certain embodiments, an extender/repeater 107 is used to communicate with the wireless sensor 102 instead of than a patient monitor 106.

Pairing with the booster/repeater may be performed in the same manner described above with respect to FIG. 9.

**[0147]** According to certain embodiments, the disclosed patient monitoring system 100 helps to manage a patient that is at risk of forming one or more pressure ulcers by, among other things, detecting changes in the patient's orientation and by determining how long the patient remains in the present orientation. Advantageously, the system 100 can detect when the patient is repositioned and begin timing the duration that the patient remains in that new orientation. Thus, if the patient repositions on his own without the observation of a care provider, the monitoring system 100 can detect the repositioning event and restart a timer.

**[0148]** The patient monitoring system 100 can aid in the administration of a clinician-established turning protocol for the patient. For example, if the patient remains in an orientation beyond a predefined, clinician-prescribed duration, the system 100 can notify the patient and/or caretakers that the patient is due to be repositioned. The wireless sensor 102 obtains sensor information indicative of the patient's orientation (*e.g.*, acceleration data), pre-processes the sensed data, and transmits it to a processing device capable of processing the measurement data, such as, for example, the patient monitor 106. Other devices capable of processing the measurement data include, without limitation, clinician devices 114, nurses' station systems 113, the multi-patient monitoring system 110, a dedicated processing node, or the like. For ease of illustration, the description herein will describe the processing device as the patient monitor 106; however, a skilled artisan will appreciate that a large number of processing devices may be used to perform the described functions without departing from the scope of the present disclosure.

**[0149]** The patient monitor 106 stores and further processes the received data to determine the patient's orientation. According to some embodiments, the patient monitor 106 can determine whether the patient is standing, sitting, or lying in the prone, supine, left side, or right side positions. The patient monitor 106 can store the determined orientation information and keep track of how long the patient remains in each determined orientation, thereby creating a continuous record of the

patient's positional history. In certain embodiments, the information received from the wireless sensor 102 can be used to create a time-sequenced representation of the patient's positional history. This representation can be displayed on the patient monitor 106 or transmitted to a nurses' station or other processing node to enable caregivers to monitor the patient's position in bed. The time-sequenced representation can be viewed in real time and/or be accessed for playback. For example, if an alarm alerts the caregiver that the patient has exceeded the maximum amount of time to remain in the present orientation, the caregiver can access and review the historical sequence of the patient's orientations prior to and during that period of time to determine the next orientation to which the patient may be repositioned. In some embodiments, the system 100 suggests the orientation to which the patient may be repositioned.

**[0150]** Illustratively, the patient monitor 106 counts the number of in-bed turns performed by the patient and displays the amount of time that has elapsed since the patient last turned. When the elapsed time exceeds a clinician-defined duration (*e.g.*, two hours), the patient monitor 106 displays an indication that the maximum time between patient turns has been exceeded. The patient monitor 106 can also transmit a notification to clinicians responsible for caring for the patient via, for example, the multi-patient monitoring system 110, a clinician notification device 114, or the like. The patient monitor 106 can also determine and display statistical information, such as the average, minimum, and maximum amount of time between turns for a given clinician-defined time period, such as for example, twenty-four hours. The patient monitor 106 can also determine and display the number of patient turns in the same orientation over a clinician-defined period of time. Similarly, the patient monitor 106 can display the total amount of time the patient has remained in each specific orientation within a clinician-defined period. Moreover, the patient monitor 106 can determine the frequency and duration of periods that the patient remained in clinically-defined acceptable orientations.

**[0151]** In some embodiments of the present disclosure, the patient monitor 106 accesses the patient's health records and clinician input via the network 108. Illustratively, the patients' positional history data, analyzed in view of the

patient's health records, may reveal or suggest a turning protocol (or other treatment protocol) that will likely yield favorable clinical outcomes for the particular patient. Accordingly, the patient monitor 106 analyzes the accessed information in conjunction with the received information from the wireless sensor 102 to determine a recommended patient turn protocol (or other treatment protocol) for the patient.

**[0152]** According to some embodiments of the present disclosure, the patient monitor 106 assesses caregiver and facility compliance with the clinician-defined turning protocol established for the patient. For example, the patient monitor 106 can identify the number of times that the patient remains in a position for a period greater than the prescribed duration, as well as the length of each such overexposure. The patient monitor 106 can also track the time between issuance of a notification, alert, or alarm and action taken in response to the event that triggered the issuance, corresponding to clinician response time.

**[0153]** FIG. 10 illustrates a method 1000 of estimating and monitoring the orientation of a patient in bed according to an embodiment of the present disclosure. The method 1000 also identifies when the patient changes orientation and keeps track of the amount of time the patient spends in in that orientation. The patient orientations that may be determined include, without limitation, whether the patient is prone, supine, on the left side, on the right side, sitting, and lying. In some embodiments, the patient monitor 106 determines the precise orientation of the patient's body. For example, the patient monitor 106 can determine the degree to which the patient's body is inclined, vertically and/or horizontally, thereby generating an accurate description of the patient's orientation relative to the support structure (such as a bed) upon which the patient lies.

**[0154]** According to an embodiment of the present disclosure, measurements from the accelerometer 210 of the wireless sensor 102 are used to determine the patient's orientation. The accelerometer 210 measures linear acceleration of the patient with respect to gravity. In some embodiments the accelerometer 210 measures linear acceleration in three axes. One axis, referred to as "roll," corresponds to the longitudinal axis of the patient's body. Accordingly, the roll reference measurement is used to determine whether the patient is in the prone

position (*i.e.*, face down), the supine position (*i.e.*, face up), or on a side. Another reference axis of the accelerometer 210 is referred to as “pitch.” The pitch axis corresponds to the locations about the patient’s hip. Thus, the pitch measurement is used to determine whether the patient is sitting up or lying down. A third reference axis of the accelerometer 210 is referred to as “yaw.” The yaw axis corresponds to the horizontal plane in which the patient is located. When in bed, the patient is supported by a surface structure that generally fixes the patient’s orientation with respect to the yaw axis. Thus, in certain embodiments of the disclosed method 1000, the yaw measurement is not used to determine the patient’s orientation when in bed.

**[0155]** Illustratively, the described method 1000 continuously or periodically (*e.g.*, every second) determines the patient’s orientation based on the measurements of pitch and roll provided by the accelerometer 210. The measurements are tracked over time, and the current measurement is compared to one or more measurements in the recent past (*e.g.*, the previous few seconds) to determine whether an orientation change event has occurred.

**[0156]** The method 1000 is described in further detail herein with respect to FIG. 10. The method 1000 begins at block 1002 in which acceleration measurement data are received from the wireless sensor 102 by a device capable of processing the measurement data, such as, for example, the patient monitor 106. Other devices capable of processing the measurement data include, without limitation, clinician devices 114, nurses’ station systems 113, the multi-patient monitoring system 110, a processing node, or the like. For ease of illustration, the description herein will describe the processing device as the patient monitor 106; however, a skilled artisan will appreciate that a large number of devices may be used to perform the described method 1000 without departing from the scope of the present disclosure.

**[0157]** The acceleration measurement data may be provided directly from the wireless sensor 102 to the patient monitor 106, or the measurement data may be relayed over a network such as network 108, by an extender/repeater 107, for example. The acceleration measurement data may be initially sampled at a

sampling rate suitable to provide an acceptable degree of precision, such as for example, 100 Hz. In some embodiments, the measured data are sub-sampled by the wireless sensor 102 before being transmitted in order to reduce power consumption of the battery 214 of the wireless sensor 102. In an embodiment, the acceleration measurement data are initially sampled at 100 Hz and subsequently down-sampled, for transmission purposes, to a rate of 26 Hz. In an embodiment, the acceleration measurement data are initially sampled at a range between approximately 10Hz and approximately 200 Hz and subsequently down-sampled, for transmission purposes, at a rate between approximately 5Hz and approximately 40Hz. A skilled artisan will understand that many other sampling rates and sub-sampling rates may be used.

**[0158]** At block 1004, the patent monitor 106 determines the present orientation of the patient. The received acceleration measurement data are processed to determine orientation values for the roll and pitch axes. The processed acceleration measurement data are provided in units of degrees, ranging from -180 degrees to +180 degrees. A lookup table, based on empirical data, provides a correlation between pairs of roll and pitch measurements and patient orientations. Illustratively, by way of non-limiting example, a roll measurement of 180 degrees can mean that the patient is on his back, and a pitch measurement of 0 degrees can mean that the patient is lying down. Thus the combination of a roll measurement of 180 degrees and a pitch measurement of 0 degrees can correspond to an orientation in which the patient is lying down on his back. Similarly, a combination of a roll measurement of 180 degrees and a pitch measurement of 90 degrees can correspond to an orientation in which the patient is lying on his right side.

**[0159]** FIG. 11A illustrates an exemplary plot 1100 of processed accelerometer 210 data over time (from 0 to 450 seconds) used to determine a patient's orientation according to an embodiment of the present disclosure. Initially, at for example, 50 seconds, the data corresponding to the roll (*i.e.*, body length) axis 1102 is at approximately 180 degrees, indicating that the patient is on his back (*i.e.*, in the supine orientation). The data corresponding to the pitch (*i.e.*, hip rotation) axis 1104 is at approximately 0 degrees, indicating that the patient is reclining. Thus,

combining the orientation information provided by the accelerometer 210 with respect to the roll and pitch axes 1102 and 1104, the patient is determined to be lying on his back. At approximately 360 seconds on the plot, denoted by vertical line 1106, we see that the patient changes orientation. During a short transition period, the data oscillates, as illustrated in the data representing the pitch axis at transition point 1108 and in the data representing the roll axis at transition point 1110. The oscillations can be caused by, among other things, jostling of the patient while moving from one position to the next. Shortly thereafter, the data achieves a steady state, as reflected by relatively stable graphs 112 and 114. Notably, the data indicative of the pitch axis 1102 has moved from approximately 180 degrees to approximately 90 degrees. This corresponds to a ninety-degree rotation of the patient's longitudinal body axis to the patient's right side. The data indicative of the roll axis remains at approximately zero degrees, indicating that the patient remains in the reclining position. Thus, combining the orientation information provided by the accelerometer 210 with respect to the roll and pitch axes 1112 and 1114, the patient is determined to be lying on his right side. In this manner, a lookup table of patient orientation change actions can be created. The table identifies profiles (*e.g.*, combinations of pitch and roll axis measurements, within certain tolerances) of various possible orientations that a patient can assume while in bed. The table of profiles of patient orientation change actions can be based on empirical data that is collected and analyzed.

**[0160]** Referring back to FIG. 10, at block 1006, previous patient orientation determinations are extracted and combined with the current orientation determinations to form a time window of patient orientation information. For example, the time window can include information indicative of the patient's orientation from one or more time periods that are in close temporal proximity to the present information indicative of the patient's orientation, such as for example, the previous few seconds. Of course, any number of previous patient orientations can be selected for the time window. In an embodiment, the patient's orientation determinations for the previous two seconds are combined with the present determination to create a three-second time window of the patient's orientation. The

purpose for creating the time window is to determine whether the patient has recently repositioned.

**[0161]** At block 1008, the time window is divided into segments for purposes of analysis. Any number of segments can be used for such analysis of the time window data. In an embodiment, the time window is segmented into three segments. In another embodiment, the time window is segmented into two segments. As illustrated in FIG. 11A at transition points 1108 and 1110, it is possible that the measured data used for the time window contains multiple sources of noise, some of which can have spikes of notable magnitude. To reduce the impact of the noise in the analysis, a segment value for each segment is determined. As disclosed at block 1010, the median value of the sampled data within each segment is used to determine the segment values for each segment. By taking the median value of each segment, a segment value is determined with minimal impact of potential noisy spikes. In certain embodiments, the segment value is a vector comprising values corresponding to each axis of measured data. Illustratively, by way of non-limiting example, each segment value comprises a vector including a roll axis segment component and a pitch axis segment component. According to some embodiments, the units of the determined segment values and/or segment components are in units of degrees ranging from -180 degrees to +180 degrees.

**[0162]** At block 1012 the median values of each segment are pairwise compared. Illustratively, by way of non-limiting example, a time window that is segmented into three sections would have three pairwise comparisons: the first segment value compared to the second segment value, the first segment value compared to the third segment value, and the second segment value compared to the third segment value.

**[0163]** At block 1014, each pairwise comparison is analyzed to determine whether an orientation change event occurred. The determination is made by comparing the magnitude of the difference of each pairwise comparison with a predetermined threshold value. If the magnitude of the difference of a pairwise comparison exceeds the threshold, then an orientation change event is considered to have occurred. If the magnitude of the difference of a pairwise comparison does

not exceed the threshold, then no change in orientation is considered to have occurred. Thus, a change that exceeds a certain threshold in the roll dimension corresponds to an orientation change event that includes a rotation about the longitudinal axis of the patient's body. Similarly, a change that exceeds a certain threshold in the pitch dimension corresponds to an orientation change event that includes a transition from sitting up to lying down, or vice versa. A change that exceeds a certain threshold in both the roll and pitch dimensions corresponds to an orientation change event that includes a rotation about the longitudinal axis of the patient's body and a transition from sitting up to lying down, or vice versa. According to an embodiment, the threshold is 45 degrees and thus, if the magnitude of difference between any two segment values is greater than 45 degrees, then an orientation change event is determined to have occurred. In another embodiment, an additional comparison is made between consecutive one-second segments of data to determine whether a change of at least 30 degrees has occurred. This is to prevent repeated posture changes, when for instance, the patient is in a posture near 135 degrees, that is, right in the middle between two postures.

**[0164]** If an orientation change event is determined to have occurred, then at block 1016, the detected event is classified. Reference is made to a look-up table of events which includes a set of profiles of orientation change actions or activities. In an embodiment, each profile includes four data points: a "before" and an "after" measurement for the roll axis, and a "before" and an "after" measurement for the pitch axis. For example, as illustrated in FIG. 11A, the profile of the orientation event activity of turning from lying on the back to lying on the right side can be as follows:

Roll Before	Roll After	Pitch Before	Pitch After
180 degrees	90 degrees	0 degrees	0 degrees

Table 1

**[0165]** As illustrated in Table 1, the roll axis changes from 180 degrees to 90 degrees indicating that the patient rotated from lying on his back to lying on his right side. The pitch axis does not change because the patient remains in a reclining

orientation. The table of events is developed and updated off-line and is based on the analysis of empirical data of known orientation change events. Accordingly, classification of orientation change events can be performed by identifying in the look-up table of events the orientation event profile that matches the data of the pairwise comparison when the magnitude of the difference of the pairwise comparison exceeds the predetermined threshold.

**[0166]** At block 1018, a vote is placed for the classified event. Illustratively, for the example described with respect to Table 1, the vote would be for the orientation change event profile of turning from lying on the back to lying on the right side. At block 1020, the method 1000 repeats the acts of determining whether an orientation change event occurred, classifying the orientation change event (if an event occurred), and voting for the classified orientation change event (again, if an event occurred), for each pairwise comparison. The maximum number of iterations for these blocks will be equal to the number of segments in the time window.

**[0167]** Once all of the pairwise comparisons have been analyzed, at block 1022, the method 1000 tallies the votes recorded at block 1018. The orientation change event that has the most votes is determined to be the orientation change event that occurred. The determined orientation change event is then reported as the orientation of the patient. At block 1024, an orientation duration timer is reset to keep track of the time the patient remains in the new orientation. The method 1000 then returns to block 1002 to begin the analysis again with respect to the next incremental (*e.g.*, second) of measurement data.

**[0168]** If at block 1014, none of the pairwise comparisons result in a detected orientation change event (*i.e.*, the patient has remained in the same orientation throughout the entire time window) then the method 1000 progresses to block 1026 to determine whether the patient has remained in the present orientation for a period of time greater than a predefined maximum duration, which may also be referred to herein as a predetermined duration or a predetermined maximum duration. If not, the method 1000 returns to block 1002 to begin the analysis again with respect to the next incremental set (*e.g.*, second) of measurement data. If the patient has remained in the present orientation for a period of time greater than the

predefined maximum duration, then at block 1028, an alert is sent to, for example, the patient's caregiver, to notify the caregiver that the patient should be repositioned. The method 1000 then returns to block 1002 to begin the analysis again with respect to the next incremental (*e.g.*, second) of measurement data.

**[0169]** FIG. 11B is an exemplary plot of an embodiment of a patient position monitoring paradigm for determining when a patient's orientation needs to be changed, according to an embodiment of the present disclosure. In an embodiment, the plot 1102B may be part of a display to a caregiver on a bedside monitor, a multi-room monitor, both, or the like. The plot can be updated in real time, at predefined intervals, and/or manually. In other embodiments, the paradigm may be illustrative of the signal processing performed by a signal processor to determine when to activate an alarm informing a caregiver of the potential of a pressure ulcer if a patient is not repositioned. In these embodiments, each portion of the paradigm may be customized to a particular patient, patient demographics, hospital protocol, unit protocol such as, for example, a protocol specific to a surgical ICU or other hospital unit, home care, or the like.

**[0170]** In the illustrated embodiment, a patient's position is monitored over time. A vertical axis 1105B represents time and a horizontal axis 1107B represents a patient movement event, such as, for example, In the illustrated embodiment, an alarm is set to alert a caregiver when a patient has been in a certain position for 3 hours or more. The illustrated embodiment is a non-limiting example, as the alarm can be set to alert the caregiver at 1 hour, 2 hours, 3 hours, 4 hours, 5 hours, 6 hours, 7 hours, 8 hours, 9 hours, and/or 10 or more hours. The alarm can include a noise, color, and/or other indicator that will alert the caregiver. In some embodiments, the alarm can indicate to the caregiver that the patient has remained in the same position for a threshold amount of time (*e.g.*, 3 hours). The threshold amount of time can be predefined or adjusted over time. In some embodiments, the alarm indicates to the caregiver that the patient has fallen, moved into an incorrect position, left the bed and/or the like. In an embodiment, empirical data about a particular patient, or a group of like patients, can be used to customized some or all of the parameters for the alarm discussed herein.

**[0171]** As shown in Figure 11B, the monitor begins monitoring a patient as the patient is in Position 1 (e.g., the patient is lying on their back, side, front, sitting slightly up, sitting mostly up, or the like). As the patient remains in Position 1, a timing mechanism starts and a line 1101B as its growth line. The slope of the line 1101B depicts a growth rate as the patient remains in the same position. As shown in the illustrated embodiment, the growth rate can be depicted linearly. In some embodiments, the growth rate can be linear, non-linear, exponential, and/or the like. In some embodiments, the growth rate is predefined. In some embodiments, the growth rate can change in real time and/or adjust to various physiological parameters and/or empirical data, as described below. The growth rate can depend on a number of factors and empirical data already known and/or determined by the system, depending on for example, how the patient's skin reacts to remaining in a single position, how fast negative effects experienced by the patient (e.g., pressure sores) form or heal, the particular position the patient is lying in, and/or demographic information about the patient, including the patient's age, health, blood perfusion rates, hydration, and/or nutrition, among others. Accordingly, in some embodiments, the growth rate can indicate a growth rate of the effects (e.g. bed sores) as the patient remains in the same position (e.g., Position 1) over a period of time.

**[0172]** As illustrated in Figure 11B, the patient remains in Position 1 for approximately 2 hours. At that time, the patient turns and/or is turned by a caregiver to Position 2. In the illustrated embodiment, Position 2 is a different position from Position 1. When the patient turns and/or is turned, the timing mechanism can restart a new line 1102B and begin to measure, track, monitor, and/or calculate the amount of time the patient remains in Position 2.

**[0173]** At the same time, line 1101B transforms into its decay line. The decay line of line 1101B can comprise data relating to a decay rate of a bed sore, potential bed sore, particular area of a patient's skin, and/or the amount of time the patient or a group of like patients, or all patients, takes to recover from remaining in a particular position (e.g., Position 1), among other things. Similar to the growth rate, the decay rate can be linear, non-linear, and/or exponential, among others. In

some embodiments, the decay rate is predefined. In some embodiments, the decay rate can change in real time and/or adjust to various physiological parameters and/or empirical data, as described below. The decay rate may depend on a number of factors and empirical data, depending on for example, how the patient's skin reacts to remaining in a single position, how fast negative effects experienced by the patient (e.g., pressure sores) heal, how quickly the patient recovers, the particular position the patient is lying in, and/or demographic information about the patient, including the patient's age, health, blood perfusion rates, hydration, and/or nutrition, among others. As shown in the illustrated embodiment, when the patient is in one or more positions that are not Position 1, the decay line of Position 1 continues to decay at the decay rate. That is, in an embodiment, the decay line of Position 1 will continue to decay at its decay rate through one or multiple other positions until it approaches zero so long as that other one or multiple positions do not include Position 1. In this example, the decay rate, or recovery rate for example, approaches zero more quickly the longer the patient remains not in Position 1.

**[0174]** In the illustrated embodiment, the patient turns and/or is turned again at Turn 2. Turn 2 occurs at a time before the threshold amount of time is reached, and therefore, before the alarm alerts the caregiver to turn the patient. At Turn 2, the patient turns/is turned to Position 3. In some examples, Position 3 is the same as Position 1. In such embodiments, because the decay line of line 1101B associated with the previous Position 1 has reached zero, a line 1104B starts at zero as its growth line for Position 3/1. However in some examples, Position 3 is a different position from Position 1. In the illustrated example, Position 3 is different from Position 1 and its growth rate for line 1104B is different from that of Position 1. In some examples, the decay line of Position 1 can continue to decay as the decay line of Position 2 continues to decay when the patient turns and/or is turned to Position 3 as long as Position 3 is different from Positions 1 and 2. In this example, the patient can continue to heal as a result of the effects of remaining in both Positions 1 and 2. In some examples, Position 1 continues to decay as the patient turned and/or is turned to multiple positions, such as a second, third, fourth, and/or fifth or more positions.

**[0175]**As shown in the illustrated embodiment, the patient remains in Position 3 for a relatively short period of time. During that time, any effects of remaining in Position 2 begin to decay. Thereafter, however the patient turns and/or is turned back to Position 2. Advantageously, rather than restarting at time zero, the system can determine that the patient has turned back to Position 2 and the timing mechanism begins timing from the current value of the decay line of Line 1102B, which corresponds to point or time 1103B. Time 1103B is greater than zero in this example, but less than the threshold amount of time. Additionally, in this example, the time 1103B is less than the amount of time the patient originally remained in Position 2. In some embodiments time 1103B can be equal to the time the patient turned from Position 2. However, in the illustrated embodiment, the system can take into account the decay rate and the time the patient has spent recovering from remaining in Position 2. Thus, in the illustrated embodiment, Time 1103B can be determined by the system through a number of methods. For example, the system can subtract the recovery time from the growth time, and/or count down from the time of the turn (e.g., Turn 2), among other methods. Advantageously, the preferred embodiment of the system can ensure the patient does not exceed the threshold total time, taking into account the growth and decay rate, a patient spends in a particular location. Although in an embodiment, the system restarts the timer at each turn, without accounting for the previous time the patient spent at a particular position, such embodiments may not be as precise in allowing adequately recovery of tissue, blood pooling, or the like caused by the previous position, and therefore, a patient may be more likely to experience negative effects (e.g., bed sores). Accordingly, the preferred embodiment of the system can more precisely reduce a likelihood of a patient developing harmful effects, such as bed sores by ensuring a patient would not remain in a particular position for too long. Once the total time spent in a position, taking into account the patient's growth and decay rates, reaches the threshold time (e.g. 3 hours in this example), an alarm can alert the caregiver.

**[0176]**In some embodiments, the alarm will alert the caregiver until the patient turns and/or is turned again, for example as illustrated by Turn 4 in Fig. 11B.

In some embodiments, the growth line will continue to grow, thus requiring longer for the line to decay, when a patient has not been turned within the threshold time. Such continued growth ensures that a patient will not be too soon returned to a position where the patient spent too much time and can help ensure that the corresponding tissue has sufficient time to recover from a particular patient position. In an embodiment, the decay rate of the line is adjusted to account for exceed the threshold limit. As shown in the illustrated embodiment, the decay rate is reduced after exceed a threshold, meaning it will take longer for the line corresponding to the alarmed position to reach zero.

**[0177]** As discussed, in an embodiment, when the patient turns and/or is turned after the time of the alarm, the growth line will exceed the threshold time, as indicated by the plot of Fig. 11B. Once the patient turns and/or is turned, the decay line can be shown above the threshold (e.g. alarm) line. In some examples, the patient may take longer to recover when the time spent in a particular position exceeds the threshold time. In some examples, the alarm can alert the caregiver that the decay line has reached the threshold time as the line continues to decay towards zero and the patient remains in a different position. In some embodiments, the alarm does not alert the caregiver that the decay line has passed the threshold time.

**[0178]** According to certain embodiments of the present disclosure, the patient monitor 106 determines the mobility status of the patient, *e.g.*, whether the patient is ambulatory, standing, sitting, reclining, or falling. The wireless monitoring system 100 can include an alert system to alert the caregiver that the patient is falling, getting out of bed, or otherwise moving in a prohibited manner or in a manner that requires caregiver attention. The alert can be an audible and/or visual alarm on the monitoring system or transmitted to a caregiver (*e.g.*, nurses' station system 113, clinician device 114, pager, cell phone, computer, or otherwise). Illustratively, the patient monitor 106 can display the patient's mobility status and transmit a notification that the patient is active and away from the bed. In some circumstances, the patient monitor 106 can determine whether the patient contravenes a clinician's order, such as, for example, instructions to remain in bed, or to walk to the bathroom

only with the assistance of an attendant. In such circumstances, a notification, alert, or alarm can be transmitted to the appropriate caregivers.

**[0179]** In certain aspects, the information received from the wireless sensor 102 can be used to create a time-sequenced representation of the patient's movement. This representation can be displayed on the patient monitor or transmitted to a nurses' station or other processing node to enable the caregiver to monitor the patient. The time-sequenced representation can be viewed in real time and/or be recorded for playback. For example, if an alarm alerts the caregiver that the patient has fallen, the caregiver can access and review the historical sequence of the patient's movements prior to and during that period of time.

**[0180]** In some embodiments, the patient monitoring system 100 can predict a patient's risk of falling based on analysis of the patient's movement (*e.g.*, gait) and other information (such as, for example, the patient's current medication regimen). When the patient monitor 106 determines that the patient's risk of falling is above a predetermined threshold, the patient monitor 106 can issue an alarm or alert to notify care providers of the identified risk in an effort to anticipate and therefore prevent a patient fall. Additionally, the patient monitor 106 can determine when a patient has fallen and issue the appropriate alarms and alerts to summon care provider assistance.

**[0181]** FIG. 12 illustrates a method 1200 of determining whether a patient has fallen according to an embodiment of the present disclosure. The method 1200 uses, among other things, information sensed by the accelerometer 210 and by the gyroscope 212 of the wireless sensor 102 to determine whether the patient has fallen. The method 1200 can be performed by the wireless sensor 102, using its processor 202 and storage device 204, or it can be performed by an external processing device that receives the sensed information from the wireless sensor 102, such as, for example, the patient monitor 106.

**[0182]** According to an embodiment of the present disclosure, measurements from the accelerometer 210 and the gyroscope 212 of the wireless sensor 102 are used, among other things, to determine whether the patient has fallen. As discussed above, the accelerometer 210 measures linear acceleration of

the patient with respect to gravity in three axes. The three axes of the accelerometer 210 are represented in fixed, inertial references. The roll axis corresponds to the longitudinal axis of the patient's body. Accordingly, the roll reference measurement is used to determine whether the patient is in the prone position (*i.e.*, face down), the supine position (*i.e.*, face up), or on a side. The pitch axis corresponds to the locations about the patient's hip. Thus, the pitch measurement is used to determine whether the patient is upright or lying down. Advantageously, the pitch axis provided by the accelerometer 210 can be a useful source of information in determining whether a patient has fallen because it can indicate a change in the patient's orientation from standing to lying, a frequently-seen scenario when a patient falls. The yaw axis corresponds to the horizontal plane in which the patient is located.

**[0183]** The gyroscope 212 provides outputs responsive to sensed angular velocity of the wireless sensor 102, as positioned on the patient, in three orthogonal axes corresponding to measurements of pitch, yaw, and roll. In contrast to the fixed, inertial reference frame relative to gravity of the accelerometer 210, the frame of reference provided by the gyroscope is relative to the patient's body, which moves.

**[0184]** At block 1202, the method 1200 begins in which acceleration measurement data and angular velocity data are received from the wireless sensor 102 by a device capable of processing the measurement data, such as, for example, the patient monitor 106. Other devices capable of processing the measurement data include, without limitation, clinician devices 114, nurses' station systems 113, the multi-patient monitoring system 110, or the like. For ease of illustration, the description herein will describe the processing device as the patient monitor 106. A skilled artisan will appreciate that a large number of devices may be used to perform the described method 1200 without departing from the scope of the present disclosure.

**[0185]** At block 1204, the received data are normalized, which may also be referred to as "scaling," to adjust values measured on different scales to a common scale, prior to further processing. According to an embodiment, training data are used to normalize the received data. The training data can include empirical data of multiple fall scenarios as well as non-fall scenarios that can be

challenging to discriminate from fall scenarios. The training data are collected and analyzed to serve as the basis for establishing a weight vector (discussed below with respect to block 1208) used to determine whether a patient has fallen. The training data can include multiple falling and non-falling scenarios, performed multiple times, by multiple subjects. Illustratively, by way of non-limiting example, the training data can include the fall and non-fall scenarios described in Table 2.

<b>Fall and Non-Fall Scenarios</b>
Fall forward from vertical, ending in left/right lateral position
Fall forward from vertical, ending in prone position
Fall backward, from vertical, ending in left/right lateral position
Fall backward from vertical, ending in supine position
Fall to left/right from vertical, ending in left/right lateral position
Fall to left/right from vertical, ending in prone position
Fall to left/right from vertical falling, ending in supine position
Collapse from vertical, ending in left/right lateral position
Collapse from vertical, ending in prone position
Collapse from vertical, ending in supine position
Fall from vertical onto knees
Fall from vertical to the left/right against a wall, sliding down
Take a step down repeatedly from a podium with left foot first
Take a step down repeatedly from a podium with right foot first
In bed: roll onto left/right side, falling out of bed
Sit down from vertical into a chair
Jump off mattress repeatedly
Stand quietly
Stumble vigorously and fall onto mattress

Table 2

[0186] As with the received data, each sample of the training data includes six dimensions of information, corresponding to the three axes of

accelerometer 210 data, and the three axes of gyroscope 212 data. Normalizing the received data standardizes the range of the variables of the received data. Since the range of values of raw data can vary widely, analytical algorithms may not work properly without normalization. For example, many classifiers calculate the distance between two points. If one of the independent variables has a broad range of values, the distance will be governed by this particular variable. Therefore, the range of all variables can be normalized so that each feature contributes approximately proportionately to the final distance. Normalization causes the values of each variable in the data to have zero-mean (when subtracting the mean in the numerator) and unit-variance. This can be performed by calculating standard scores. The general method of calculation is to determine the distribution mean and standard deviation for each variable of the entire set of training data. Next each determined mean is subtracted from the corresponding variable of the received data. Then the new value of each variable (having the mean already subtracted) is divided by the determined standard deviation. The result is a normalized set of values that can be further processed by the method 1200.

**[0187]** At block 1206, the normalized set of values is processed to determine features that are useful in determining whether a patient is falling. According to an embodiment, the method determines the following five features: the magnitude of the acceleration data (provided by the accelerometer 210), the magnitude of the angular velocity data (provided by the gyroscope 212), the magnitude of the jerk (*i.e.*, the rate of change of acceleration); the fall duration which is used to characterize a fall starting point and a fall impact point, and the change in pitch between two consecutively received data points. Other features can be used in determining whether a patient is falling such as, by way of non-limiting example, vertical velocities.

**[0188]** The magnitude of the received acceleration data is determined by calculating the Euclidian norm of the three-dimensional vector made up of the measurements from the accelerometer's 210 three axes. As is well understood by an artisan, this corresponds to the square root of the sum of the squares of the three accelerometer values, pitch, roll and yaw. Similarly, the magnitude of the angular

velocity data is determined by calculating the Euclidian norm of the three-dimensional vector made up of the measurements from the gyroscope's 212 three axes. The magnitude of the jerk, which can also be referred to as "jolt," "surge," or "lurch," is calculated by taking the derivative of the acceleration vector, and then calculating the Euclidean norm of the derivative.

**[0189]** The fall duration, which is a scalar value, is determined by evaluating the acceleration magnitude profile of the patient's motion over a short duration of time. In particular, as the fall begins, acceleration of the patient relative to gravity decreases because the patient is falling. (A patient that is not falling would register an acceleration value in the up and down dimension equal to the force of gravity (*i.e.*, 1g or approximately 9.80665 m/s<sup>2</sup>). Thus, if the magnitude of the acceleration is below a first threshold, then it is considered to be a starting point of a fall, and the value of the fall duration is incremented by 1. If the magnitude of the acceleration is above the first threshold, then the value of the fall duration is decremented by 1. In an embodiment, the first threshold is 0.6g (or approximately 5.88399 m/s<sup>2</sup>). A second threshold is used to determine the impact point of the fall. In an embodiment, the second threshold is 0.8g (or approximately 7.84532 m/s<sup>2</sup>). If the magnitude of the acceleration is below the second threshold, then it is considered to be an impact point of the fall, and the value of the fall duration is incremented by 1. If the magnitude of the acceleration is above the second threshold, then the value of the fall duration is decremented by 1.

**[0190]** The pitch change feature is the result of a comparison of the present pitch orientation (as determined by the accelerometer 210 data) with the pitch orientation determined one second earlier. As discussed above, the pitch dimension of the accelerometer data is useful in detecting a fall because it distinguishes between the patient being in an upright position (*e.g.*, standing up or sitting up) and reclining. Thus a change in pitch from being upright to reclining can indicate that a fall has occurred. The output of block 1206 is a five-dimensional feature vector made up of the five determined features.

**[0191]** At block 1208, a weight vector of values is applied to the determined features. According to certain embodiments, the inner product of the

received five-dimensional feature vector and a weight vector is calculated. In certain embodiments, the weight vector is derived using a machine learning algorithm. Machine learning is a sub-field of computer science based on the study of pattern recognition and computational learning theory in artificial intelligence. It includes the development of algorithms that can learn from and make predictions on data. Algorithms developed through machine learning operate by building a model from example inputs in order to make data-driven predictions or decisions, rather than following strictly static program instructions. Machine learning is employed in a range of computing tasks where use of explicit computer programs is infeasible. When employed in industrial contexts, machine learning methods may be referred to as predictive analytics or predictive modelling. As applied in the present disclosure, the machine learning system includes supervised learning, where the machine learning algorithm is presented with training data that include example inputs and their known outputs, given by a "teacher", and the goal is to learn a general rule that maps the inputs to the outputs. In an embodiment, Fisher's linear discriminant is employed to derive the weight vector. Fisher's linear discriminant is a method used to find a linear combination of features that characterizes or separates two or more classes of objects or events. The resulting combination may be used as a linear classifier or for dimensionality reduction before later classification. Other methods of machine learning that can be used with the present disclosure include, without limitation, linear discriminant analysis, analysis of variance, regression analysis, logistic regression, and probit regression, to name a few. A skilled artisan will recognize that many other machine learning algorithms can be used to determine the weight vector without departing from the scope of the present disclosure.

**[0192]** The training data, described above, include empirical data collected from multiple fall and non-fall scenarios which can be used to identify the predictive indicators of patient falls. Illustratively, for each training scenario, the five features described above with respect to block 1206 are determined and provided as input to the machine learning system. Additionally, an output is provided for each training scenario that identifies whether the scenario describes a falling event or a non-falling event. The machine learning system analyzes the training data to derive a

rule that maps the inputs to the outputs. According to certain embodiments of the present disclosure, the output of the machine learning system is five-dimensional weight vector that weights each of the five features according to their relative value in determining whether or not a fall has occurred. The weight vector is determined off-line and is provided as a fixed, five-dimensional vector to the method 1200. Of course, the weight vector can be updated, based on analysis of additional empirical data.

**[0193]** The inner product (also referred to as the “dot product” and the “scalar product”) of the received five-dimensional feature vector and the weight vector is calculated in a manner well understood by skilled artisans. The inner product yields a scalar value, also referred to herein as an activation value, that may be either positive or negative. At block 1210, the method 1200 determines whether a fall has been detected. According to some embodiments, the sign of the inner product of the received five-dimensional feature vector and the weight vector indicates whether a fall has occurred. If the inner product is less than zero, then no fall has been detected, and the method returns to block 1202 to begin analyzing the next set of data from the wireless sensor 102. If the inner product is greater than zero, then a fall has been detected and the method 1200 progresses to block 1214, where a notification, alarm, and/or alert indicating that the patient has fallen is transmitted to, for example, clinician devices 114, nurses’ station systems 113, multi-patient monitoring system 110, and the like. The method returns to block 1202 to begin analyzing the next set of data from the wireless sensor 102.

**[0194]** In some embodiments, the system can determine a spatial location of the patient within the patient’s room. The system can monitor the room and spatially monitor and/or calculate how long the patient has been in a position, when the patient was in the position, and/or how long the patient was in the position, among other parameters. As discussed above, the system uses, among other things, information sensed by the accelerometer 210 and by the gyroscope 212 of the wireless sensor 102 to track the patient. This method can be performed by the wireless sensor 102, using its processor 202 and storage device 204, or it can be

performed by an external processing device that receives the sensed information from the wireless sensor 102, such as, for example, the patient monitor 106.

**[0195]** In some embodiments, the system can determine the position of the patient within the patient's room, relative to certain features of the patient's room, such as the patient's bed, a bathroom, a monitor, a doorway, and/or a window, among other room feature. In particular, using methods described herein, the system can determine a patient's vertical position, vertical displacement, horizontal position, horizontal displacement, angular position and/or angular displacement in the patient's room. For example, the accelerometer 210 and/or the gyroscope 212 can monitor the patient's movements as the patient walks throughout the patient's room. The system can determine whether the patient is falling, getting out of bed, or otherwise moving in a prohibited manner or in a manner that requires caregiver attention.

**[0196]** According to some embodiments, measurements from the accelerometer 210 and the gyroscope 212 of the wireless sensor 102 are used, among other things, to determine whether the patient is bending down and/or has fallen and/or where the patient has fallen (for example, by measuring the vertical displacement of the patient and/or the height of the patient relative to the floor). In some embodiments in which the patient has fallen, the clinician can determine the location of the fall according to an embodiment of the present disclosure. As discussed above, the accelerometer 210 measures linear acceleration of the patient with respect to gravity in three axes. The three axes of the accelerometer 210 are represented in fixed, inertial references. The gyroscope 212 provides outputs responsive to sensed angular velocity of the wireless sensor 102, as positioned on the patient, in three orthogonal axes corresponding to measurements of pitch, yaw, and roll. Based on these measurements, the system can determine whether the patient has fallen according to methods described herein.

**[0197]** In such configurations, the system can record the position of the patient. In certain aspects, the information received from the wireless sensor 102 can be used to create a time-sequenced representation of the patient's movement. This representation can be displayed on the display 120 or transmitted to a nurses'

station or other processing node to enable the caregiver to monitor the patient. The time-sequenced representation can be viewed in real time and/or be recorded for playback. For example, if an alarm alerts the caregiver that the patient has fallen, the caregiver can access and review the historical sequence of the patient's movements prior to and during that period of time.

**[0198]** Figures 15A-H illustrate various configurations of a room display displayed on the patient display monitor. As illustrated in Figures 15A-H, the caregiver and/or patient can select any number of room items and/or configurations of the room items. The caregiver can select a room item, and place it within the room on the room display. The caregiver can rotate and/or place the room item in any configuration. In an embodiment, the caregiver could select the location of a major element of a room at a time. For example, the caregiver could select a position of the bed, then a position of the bathroom, then a position of the door, equipment, tables, chairs, couches, etc. In other embodiments, various room layout approximations are some to fully presented in selection screens and the determination of layout is made in one or just a few caregiver selections.

**[0199]** Figure 16 illustrates an example method 1600 for detecting and/or predicting a patient's fall, determining a particular location of a patient within a patient's room, and/or determining whether the patient has moved outside of a prescribed movement of the patient, among others, for example.

**[0200]** At block 1602, the caregiver can enter a room configuration. For example, the caregiver can select any number of room items to be displayed in any number of configurations within a patient room display. The room items can include a patient's bed, a bathroom, a monitor, a doorway, and/or a window, among other room items. The caregiver can select a room item by selecting, dragging, and/or dropping each room item around the room display. In some embodiments, the caregiver can select a certain size for each room item. In some embodiments, the caregiver can simply select a room item and select the location within the room display for the room item to be oriented and displayed. In some embodiments, the room item can be snapped into place in the room display.

**[0201]** At block 1604, the caregiver can optionally enter a movement prescription. For example, the caregiver can enter instructions to the patient, including instructions to remain in bed, and/or to walk to the bathroom only with the assistance of an attendant.

**[0202]** At block 1608, one or more of the sensors described herein can be activated. In some examples, the caregiver manually activates the one or more sensors. In some examples, the system activates the one or more sensors automatically to begin tracking, monitoring, measuring, and/or calculating certain physiological parameters, according to methods described herein.

**[0203]** At block 1610, the patient monitoring system 100 can predict and/or detect a patient's fall and/or risk of falling based on analysis of the patient's movement (*e.g.*, gait) and other information (such as, for example, the patient's current medication regimen). At block 1612, when the patient monitor 106 determines that the patient's risk of falling is above a predetermined threshold, the patient monitor 106 can issue an alarm or alert to notify care providers of the identified risk in an effort to anticipate and therefore prevent a patient fall. Additionally, the patient monitor 106 can determine when a patient has fallen and issue the appropriate alarms and alerts to summon care provider assistance. The alert system can alert the caregiver that the patient is falling, getting out of bed, or otherwise moving in a prohibited manner or in a manner that requires caregiver attention. The alert can be an audible and/or visual alarm on the monitoring system or transmitted to a caregiver (*e.g.*, nurses' station system 113, clinician device 114, pager, cell phone, computer, or otherwise).

**[0204]** If the patient monitoring system has not detected a patient's fall, the patient monitoring system 100 can optionally determine whether the patient has moved outside of the movement prescription. For example, as described above, the patient monitor 106 can determine the mobility status of the patient, *e.g.*, whether the patient is ambulatory, standing, sitting, reclining, or falling.

**[0205]** If the patient monitoring system 100 determines that the patient has contravened a caregiver's order, such as, for example, instructions to remain in bed,

or to walk to the bathroom only with the assistance of an attendant, a notification, alert, or alarm can be transmitted to the appropriate caregivers at block 1612.

**[0206]** If the patient monitoring system 100 determines that the patient has not contravened a caregiver's order, the system will return to block 1610 to detect and/or predict whether the patient has fallen.

**[0207]** FIGS. 13A-F illustrate embodiments of icon displays reflecting a patient's position according to an embodiment of the present disclosure. According to some embodiments, the graphical icons are used to visually depict the detected orientation of the patient. In particular, the icons of FIGS. 13A-F show, in stick figure-type format, the patient sitting, standing, and lying in the supine position (on the back), the prone position (on the belly), on the left side, and on the right side, respectively.

**[0208]** FIG. 14 illustrates an example of how the icons described with respect to FIGS. 13A-F can be presented on the display 120 of the patient monitor 106. Toward the bottom of the main display 120 are a set of 3 icons 1402, 1404, and 1406 indicating the patient's position. The left-most icon 1404 shows the patient lying on his right side. The two icons to the right of the left-most icon 1404 and 1406 show the patient lying on his back. According to certain embodiments, the display 120 of the patient monitor 106 can include a touchscreen interface. The touchscreen interface can enable finger controls, including a touch gesture, a touch and move gesture, and a flick gesture. Illustratively, a clinician may use the touch gesture on an icon 1406 to expand the icon in the display 120 to include additional information associated with that icon 1406. For example, additional information associated with the "touched" icon 1406 can include, the time at which the patient assumed the particular orientation, the time (if available) at which the patient moved from the orientation, the total duration of time the patient spent in the particular orientation, the number of discrete times that the patient has been in the particular orientation over a defined period (such as 24 hours), the total duration of time that the patient the patient has been in the particular orientation over a defined period (such as 24 hours), and the like. The clinician may also use the flick finger gesture

to scroll right and left, corresponding to moving forward and backward in time, to access the historical positional record of the patient.

**[0209]** The service life of the wireless sensor 102 disclosed herein can vary depending on, among other things, battery size, and data transmission characteristics such as data rate, frequency of transmission, and quantity of data transmitted. According to one embodiment, the wireless sensor 102 is configured to operate continuously or near continuously (*e.g.*, waking up every second or so to sense and transmit the patient's physiological data) for approximately two days, after which the wireless sensor 102 is to be disposed of properly. Other embodiments of the wireless sensor 102, equipped with a larger battery, for example, are configured to operate for longer periods of time before disposal. Some embodiments can be configured for sterilization and reuse.

**[0210]** Certain medical device manufacturers implement quality control measures for disposable medical devices, such as embodiments of the disclosed wireless sensor 102, to carefully control and manage the performance characteristics of their disposable devices. In particular, there is a risk that used and disposed-of wireless sensors 102 can be salvaged and refurbished or retrofitted for additional use beyond the defined and intended service life of the wireless sensor 102. Features can be included in the disclosed patient monitoring system 100 to help prevent improper use of the wireless sensor 102 beyond its defined service life.

**[0211]** According to one embodiment of the patient monitoring system 100, the wireless sensor 102 is configured to set an activation flag in the storage device 204 of the wireless sensor 102 upon initial activation, indicating that the wireless sensor 102 has been activated for use. In some embodiments, the activation flag is set in an information element 215 which is provided to store information about the usage of the wireless sensor 102 to help maintain quality control. Advantageously, the activation flag is set in nonvolatile memory of the storage device 204, or in the information element 215, so that disconnection from the battery 214 will not disrupt or erase the set activation flag. Thus, if the wireless sensor 102 is reconditioned such that it may be activated a second time, the activation flag will indicate, through a standard sensor 102 start-up routine, that the

sensor 102 has been previously activated. Upon detection of the activation flag, the wireless sensor 102 can transmit a prior activation message and/or alert which can serve as a warning notification that the quality of the sensor 102 may be compromised. The transmitted warning or alert can be received by, for example, a patient monitor 106 which can then provide a menu of actions that the user may take in response to the transmitted quality warning or alert. The menu of actions can include the option to shut down the wireless sensor 102. In certain situations it may be desirable to continue to use the wireless sensor 102. Illustratively, it is possible that the battery 214 connection to the wireless sensor 102 is established and then unintentionally disconnected. For example, a battery isolator 322 may be initially removed from the sensor 102 but then re-inserted so as to once again isolate the battery 214 from the electronic circuitry of the wireless sensor 102. Removing the battery isolator 322 a second time will result in transmission of a quality warning or alert as described above. In such a situation the user, being aware of the circumstances that led to the quality warning, may choose to continue to use the wireless sensor 102.

**[0212]** According to another embodiment, the wireless sensor 102 is configured to set a prolonged service flag, after the wireless sensor has been in an activated state for a predefined period of time, such as, for example, four hours. The prolonged service flag can serve to indicate upon start-up that the sensor 102 has previously been active for a prolonged duration of time. In another embodiment, the wireless sensor 102 tracks and records on the storage device 204 the duration of time that the sensor 102 has been active. Advantageously, the sensor 102 can issue notifications and/or alerts to the user that the sensor 102 is nearing the end of service life, providing the user an opportunity to take steps to replace the wireless sensor 102 before it ceases to operate. Additionally, the recorded duration of time that the sensor 102 has been active can serve to detect when a sensor 102 has been refurbished to operate beyond its intended service life. The appropriate warning can then be transmitted to the user. According to some embodiments, once the wireless sensor has been active for a period of time equal to a maximum service

life duration, the sensor 102 sets a flag in the storage device 204, or otherwise configures itself to prohibit the sensor 102 from operating further.

**[0213]** In other embodiments, the wireless sensor 102 transmits to the patient monitor 106 a unique identifier such as, for example, a product serial number that is encoded in one of the hardware components of the wireless sensor 102. Once the wireless sensor 102 is paired with a patient monitor or with an expander/repeater 107 and is operational, the patient monitor 106 or the expander/repeater 107 can transmit the sensor's 102 unique identifier to a central repository that lists the unique identifiers of sensors 102 known to have been operational. Illustratively, during the pairing operation, the patient monitor 106 or the expander/repeater 107 can check the central repository to determine whether the wireless sensor 102 that is attempting to pair has been listed on in the central repository, thereby indicating that the wireless sensor 102 might have quality issues.

**[0214]** In other various embodiments, the wireless sensor 102 includes a sensor information element 215, which can be provided through an active circuit such as a transistor network, memory chip, EEPROM (*electronically erasable programmable read-only memory*), EPROM (*erasable programmable read-only memory*), or other identification device, such as multi-contact single wire memory devices or other devices, such as those commercially available from Dallas Semiconductor or the like. The sensor information element 215 may advantageously store some or all of a wide variety of information, including, for example, sensor type designation, sensor configuration, patient information, sensor characteristics, software such as scripts or executable code, algorithm upgrade information, software or firmware version information, or many other types of data. In a preferred embodiment, the sensor information element 215 may also store useful life data indicating whether some or all of the sensor components have expired.

**[0215]** Many other variations than those described herein will be apparent from this disclosure. For example, depending on the embodiment, certain acts, events, or functions of any of the algorithms described herein can be performed in a different sequence, can be added, merged, or left out altogether (*e.g.*, not all described acts or events are necessary for the practice of the algorithms). Moreover,

in certain embodiments, acts or events can be performed concurrently, *e.g.*, through multi-threaded processing, interrupt processing, or multiple processors or processor cores or on other parallel architectures, rather than sequentially. In addition, different tasks or processes can be performed by different machines and/or computing systems that can function together.

**[0216]** The various illustrative logical blocks, modules, and algorithm steps described in connection with the embodiments disclosed herein can be implemented as electronic hardware, computer software, or combinations of both. To clearly illustrate this interchangeability of hardware and software, various illustrative components, blocks, modules, and steps have been described above generally in terms of their functionality. Whether such functionality is implemented as hardware or software depends upon the particular application and design constraints imposed on the overall system. The described functionality can be implemented in varying ways for each particular application, but such implementation decisions should not be interpreted as causing a departure from the scope of the disclosure.

**[0217]** The various illustrative logical blocks and modules described in connection with the embodiments disclosed herein can be implemented or performed by a machine, such as a general purpose processor, a digital signal processor (DSP), an application specific integrated circuit (ASIC), a field programmable gate array (FPGA) or other programmable logic device, discrete gate or transistor logic, discrete hardware components, or any combination thereof designed to perform the functions described herein. A general purpose processor can be a microprocessor, but in the alternative, the processor can be a controller, microcontroller, or state machine, combinations of the same, or the like. A processor can include electrical circuitry configured to process computer-executable instructions. In another embodiment, a processor includes an FPGA or other programmable device that performs logic operations without processing computer-executable instructions. A processor can also be implemented as a combination of computing devices, *e.g.*, a combination of a DSP and a microprocessor, a plurality of microprocessors, one or more microprocessors in conjunction with a DSP core, or any other such configuration. A computing environment can include any type of

computer system, including, but not limited to, a computer system based on a microprocessor, a mainframe computer, a digital signal processor, a portable computing device, a device controller, or a computational engine within an appliance, to name a few.

**[0218]** The steps of a method, process, or algorithm described in connection with the embodiments disclosed herein can be embodied directly in hardware, in a software module stored in one or more memory devices and executed by one or more processors, or in a combination of the two. A software module can reside in RAM memory, flash memory, ROM memory, EPROM memory, EEPROM memory, registers, hard disk, a removable disk, a CD-ROM, or any other form of non-transitory computer-readable storage medium, media, or physical computer storage known in the art. An example storage medium can be coupled to the processor such that the processor can read information from, and write information to, the storage medium. In the alternative, the storage medium can be integral to the processor. The storage medium can be volatile or nonvolatile. The processor and the storage medium can reside in an ASIC.

**[0219]** Conditional language used herein, such as, among others, "can," "might," "may," "e.g.," and the like, unless specifically stated otherwise, or otherwise understood within the context as used, is generally intended to convey that certain embodiments include, while other embodiments do not include, certain features, elements and/or states. Thus, such conditional language is not generally intended to imply that features, elements and/or states are in any way required for one or more embodiments or that one or more embodiments necessarily include logic for deciding, with or without author input or prompting, whether these features, elements and/or states are included or are to be performed in any particular embodiment. The terms "comprising," "including," "having," and the like are synonymous and are used inclusively, in an open-ended fashion, and do not exclude additional elements, features, acts, operations, and so forth. Also, the term "or" is used in its inclusive sense (and not in its exclusive sense) so that when used, for example, to connect a list of elements, the term "or" means one, some, or all of the elements in the list. Further, the term "each," as used herein, in addition to

having its ordinary meaning, can mean any subset of a set of elements to which the term "each" is applied.

**[0220]** While the above detailed description has shown, described, and pointed out novel features as applied to various embodiments, it will be understood that various omissions, substitutions, and changes in the form and details of the systems, devices or methods illustrated can be made without departing from the spirit of the disclosure. As will be recognized, certain embodiments described herein can be embodied within a form that does not provide all of the features and benefits set forth herein, as some features can be used or practiced separately from others.

**[0221]** The term "and/or" herein has its broadest, least limiting meaning which is the disclosure includes A alone, B alone, both A and B together, or A or B alternatively, but does not require both A and B or require one of A or one of B. As used herein, the phrase "at least one of" A, B, "and" C should be construed to mean a logical A or B or C, using a non-exclusive logical or.

**[0222]** The apparatuses and methods described herein may be implemented by one or more computer programs executed by one or more processors. The computer programs include processor-executable instructions that are stored on a non-transitory tangible computer readable medium. The computer programs may also include stored data. Non-limiting examples of the non-transitory tangible computer readable medium are nonvolatile memory, magnetic storage, and optical storage.

**[0223]** Although the foregoing disclosure has been described in terms of certain preferred embodiments, other embodiments will be apparent to those of ordinary skill in the art from the disclosure herein. Additionally, other combinations, omissions, substitutions and modifications will be apparent to the skilled artisan in view of the disclosure herein. Accordingly, the present invention is not intended to be limited by the description of the preferred embodiments, but is to be defined by reference to claims.

WHAT IS CLAIMED IS:

1. A system for monitoring an orientation of a patient's back to reduce a risk of the patient developing a pressure ulcer on a portion of the patient's body, the system comprising:

a sensor including an accelerometer, a processor, and a first wireless transceiver, said sensor configured to output a signal indicative of a possible change in an orientation of a back of said patient when said sensor is positioned on a portion of the patient's back; and

a patient monitor comprising a signal processor, a memory device, a storage device, and a second wireless transceiver, said second wireless transceiver is configured to receive said signal from said sensor positioned on the portion of the patient's back, and said signal processor is configured to process said signal to determine whether said possible change corresponds to an actual change in said orientation of the patient's back, when said actual change has occurred, configured to record a patient turn event, to compare said patient turn event with a patient turn protocol, and when said possible change is not said actual change and no patient turn event occurs according to the patient turn protocol, said patient monitor is configured to notify a caregiver of a patient turn protocol violation,

wherein said signal processor is configured to determine whether said possible change corresponds to said actual change includes being configured to determine a difference between said orientation of said patient's back at a previous time and at a current time based at least on said signal, and when said difference is above a threshold, recording said patient turn event.

2. The system of Claim 1, wherein the sensor is affixed to the patient's back between shoulder blades of the patient.

3. The system of Claim 1, wherein the portion of the patient's back is an upper portion of the patient's back.

4. The system of Claim 1, wherein the portion of the patient's back is at approximately a center of the patient's back.

5. The system of Claim 1, wherein said signal processor of said patient monitor is further configured to reset a patient orientation duration timer when said processor records said patient turn event.

6. The system of any one of Claims 1 to 5, comprising a third wireless transceiver, said third wireless transceiver configured to receive said signal from said sensor and to transmit said signal to said patient monitor.

7. The system of Claim 6 comprising a power supply for said third wireless transceiver different from a power supply for said sensor or said patient monitor.

8. The system of any one of Claims 1 to 7, wherein said sensor comprises a gyroscope.

9. The system of any one of Claims 1 to 8, wherein said sensor comprises an acoustic sensor.

10. The system of any one of Claims 1 to 9, wherein said sensor comprises a temperature sensor.

11. The system of any one of Claims 1 to 10, wherein said sensor comprises an ECG sensor.

12. The system of any one of Claims 1 to 11, wherein said sensor comprises one or more of an acoustic sensor, a temperature sensor and an ECG sensor.

13. The system of any one of Claims 1 to 12, wherein said patient monitor is configured to determine measurements of one or more of the following parameters: an acceleration, an angular velocity, a magnetic field, a respiration rate, a temperature, an impedance value, a moisture value, an oximetry value and an electrocardiogram.

14. The system of any one of Claims 1 to 13, wherein said portion of said patient's back is approximately flat.

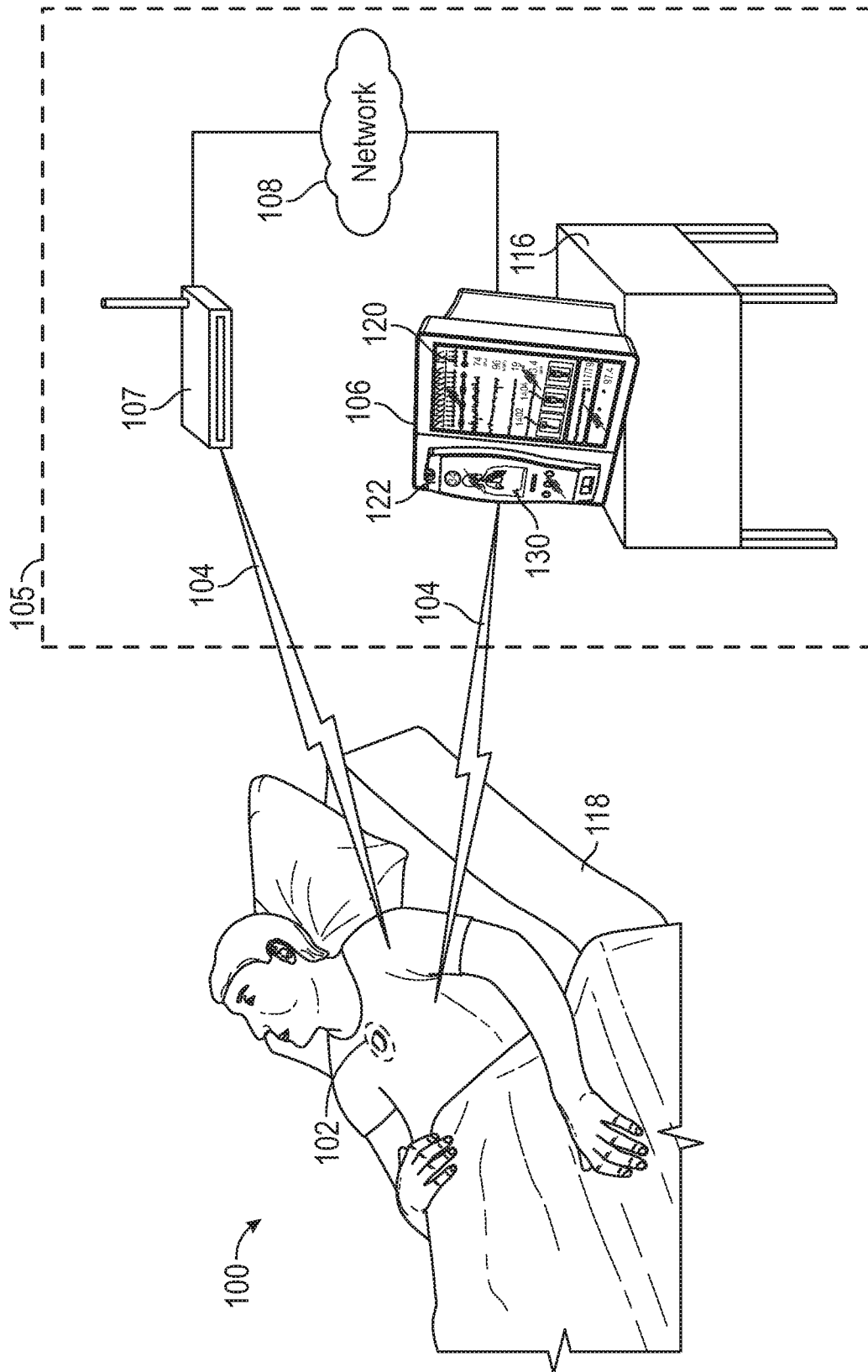

FIG. 1A

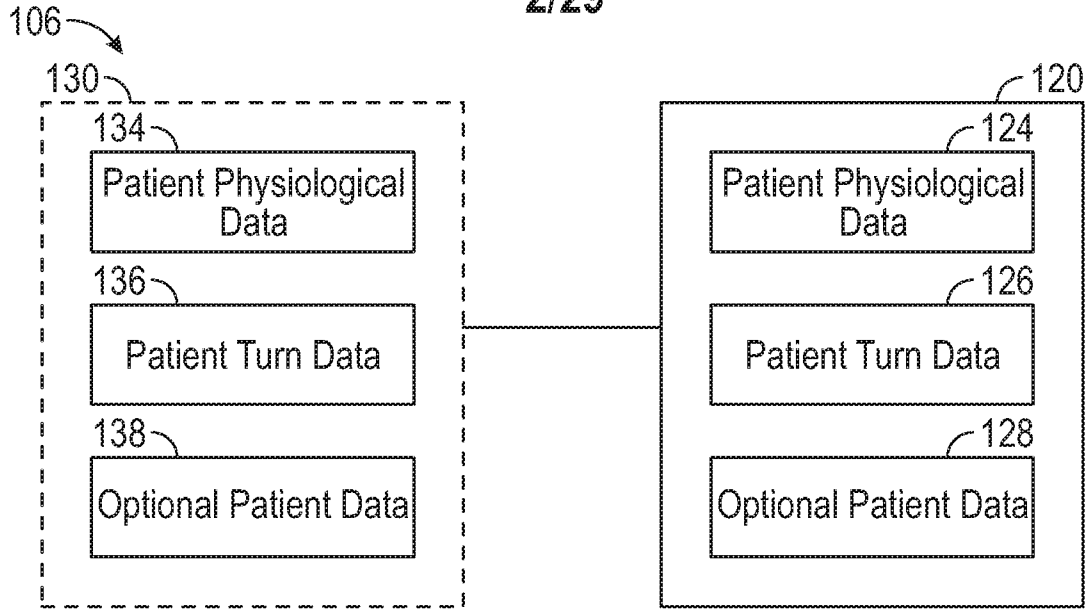

FIG. 1B

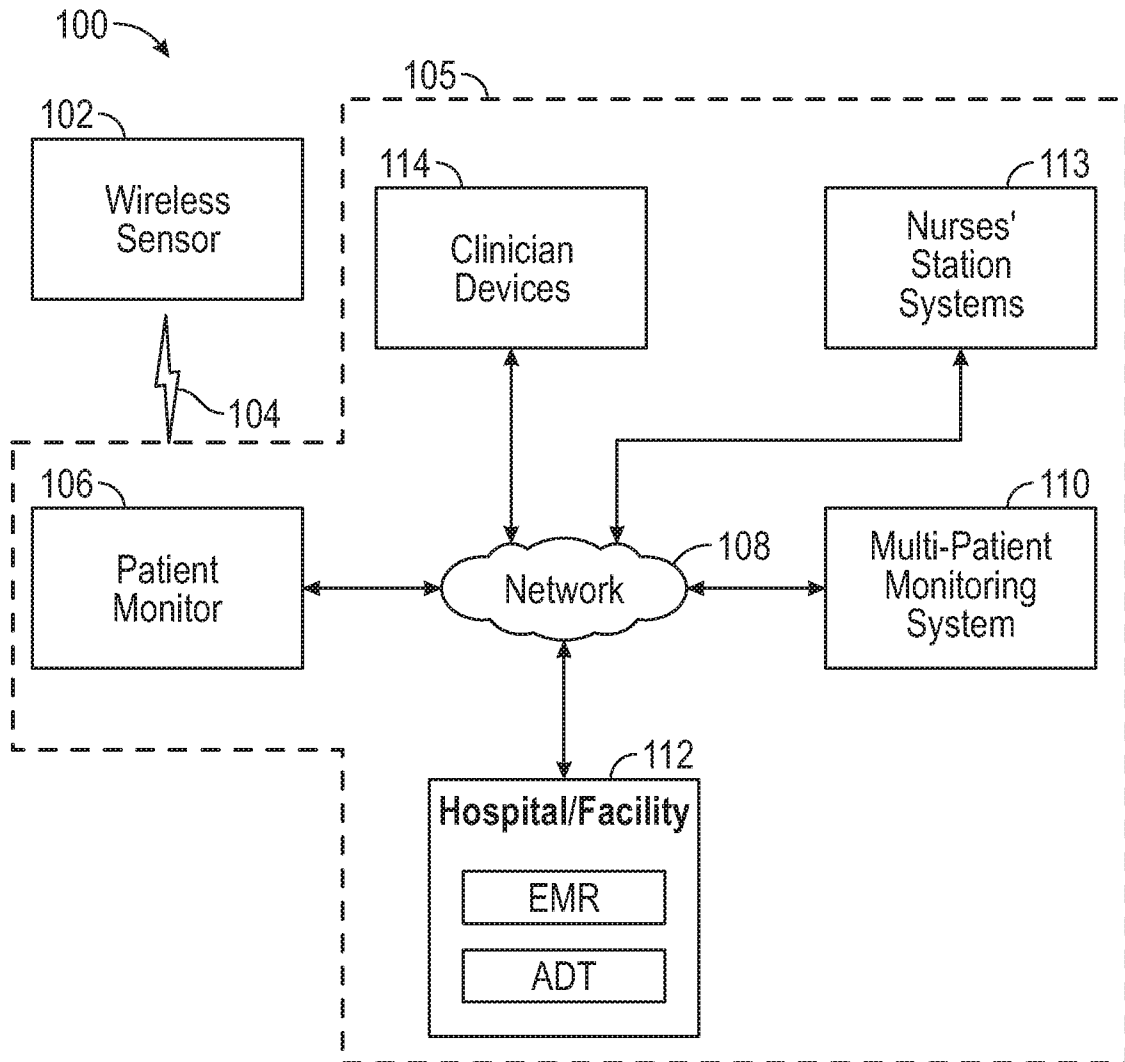

FIG. 1C

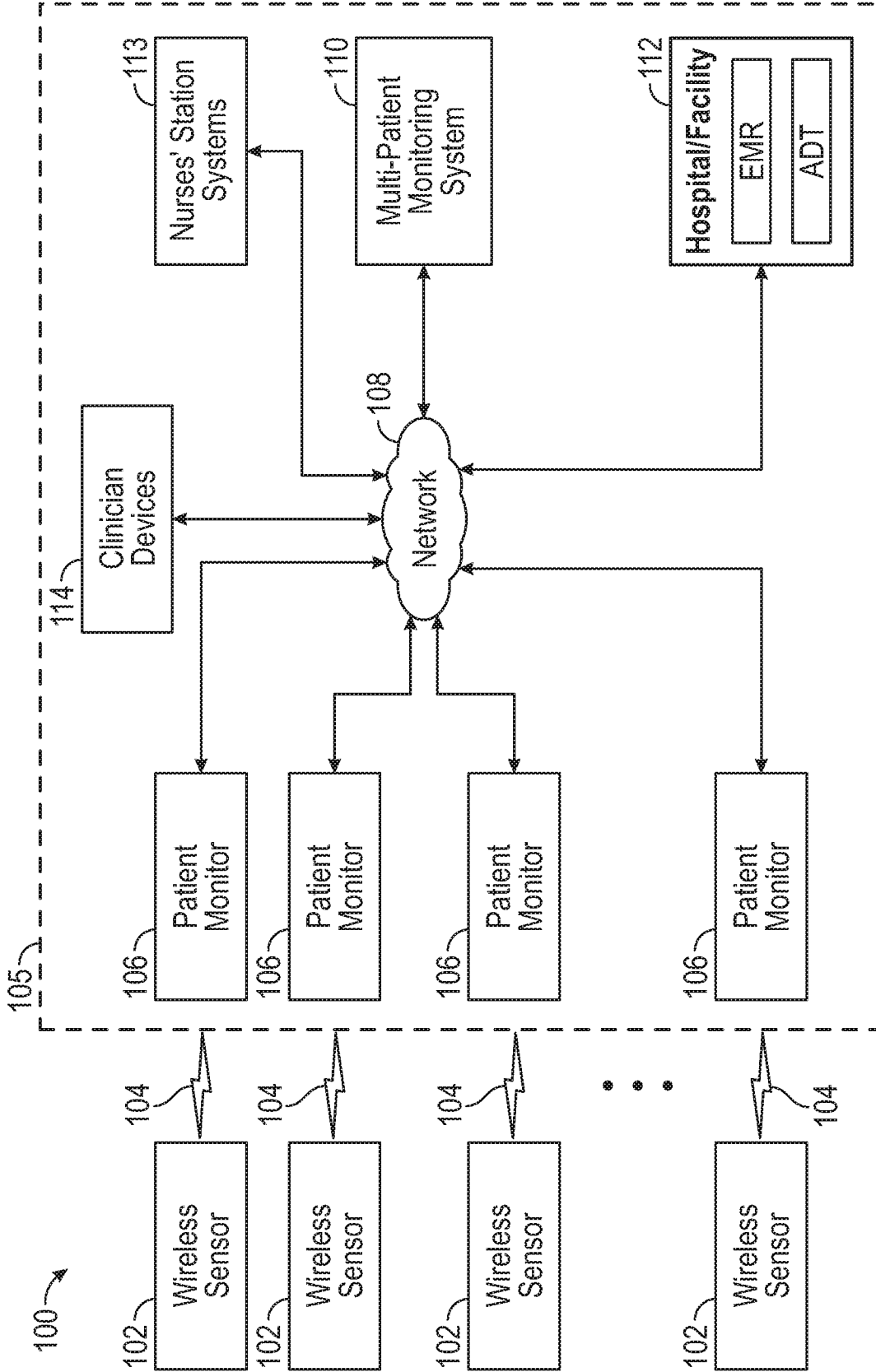

FIG. 1D

4/29

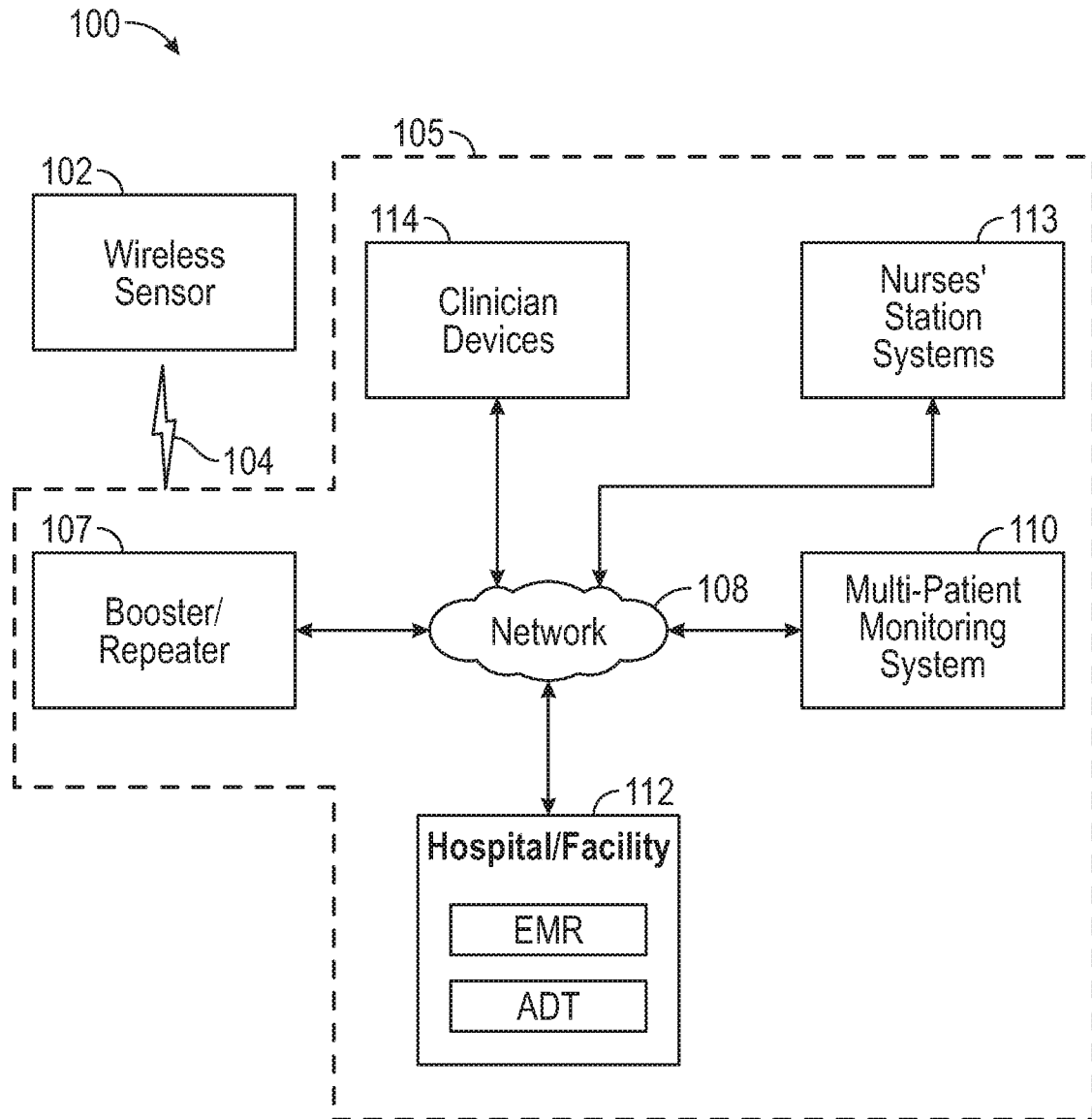

FIG. 1E

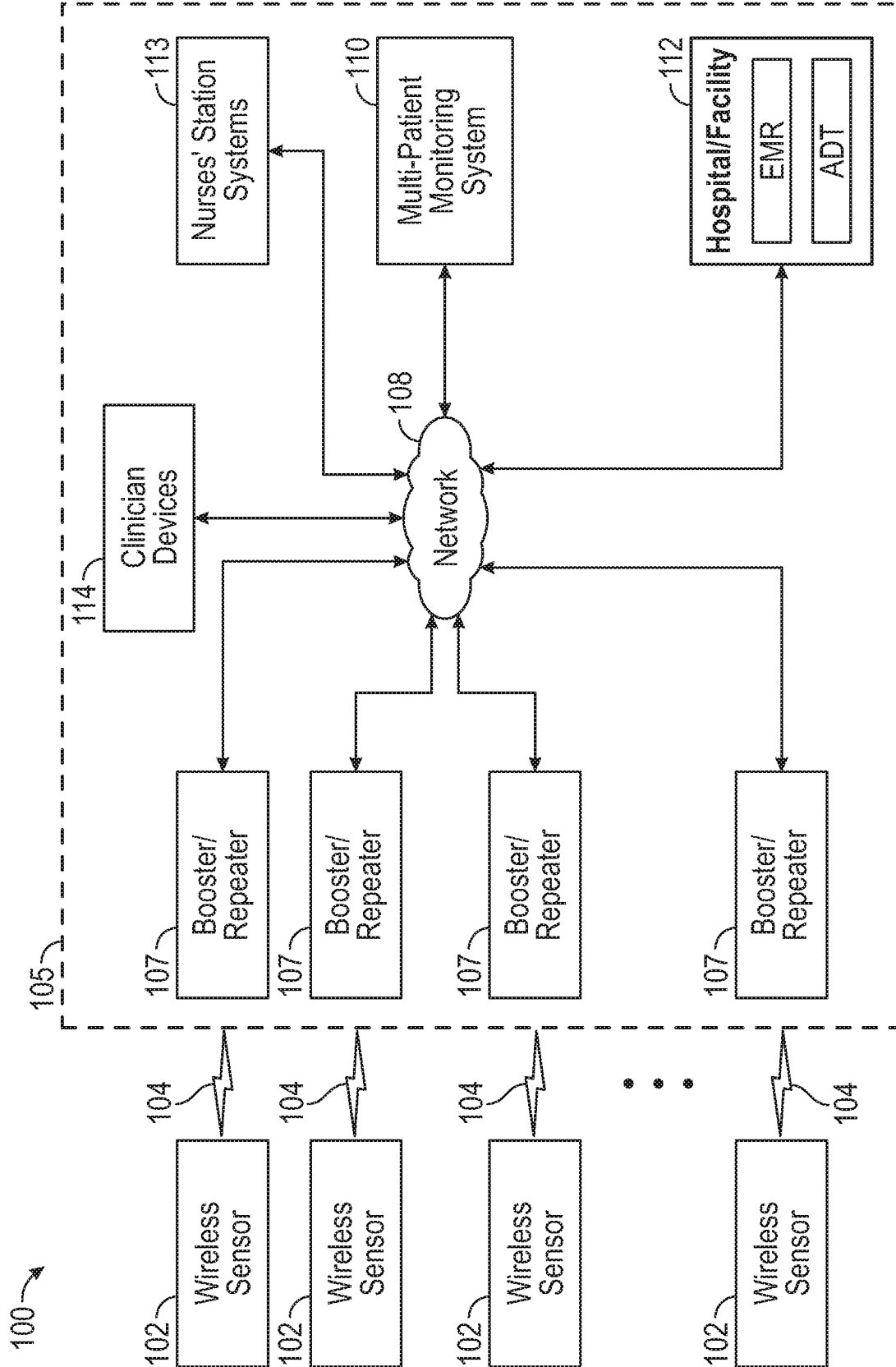

FIG. 1F

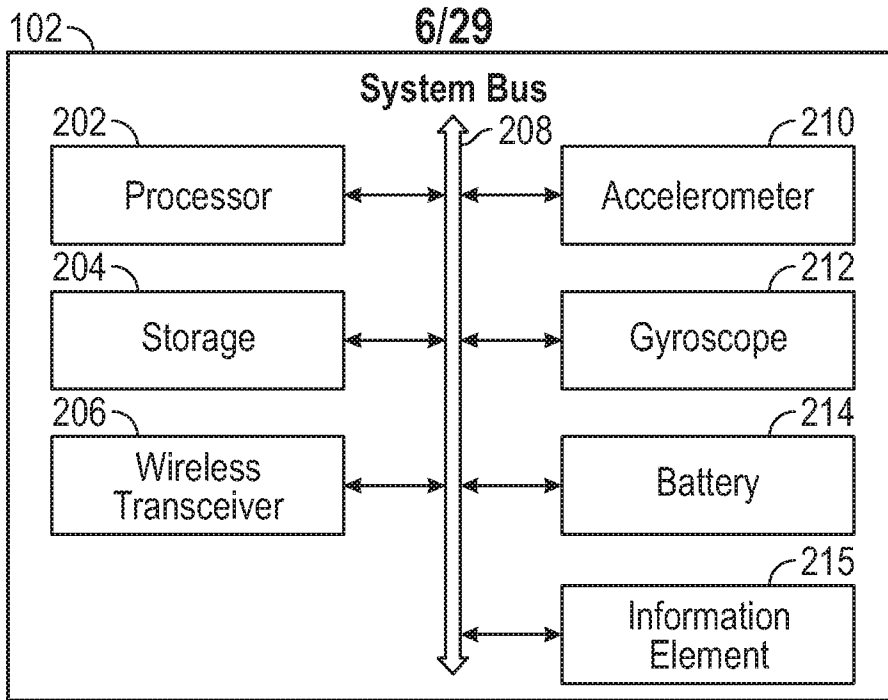

FIG. 2A

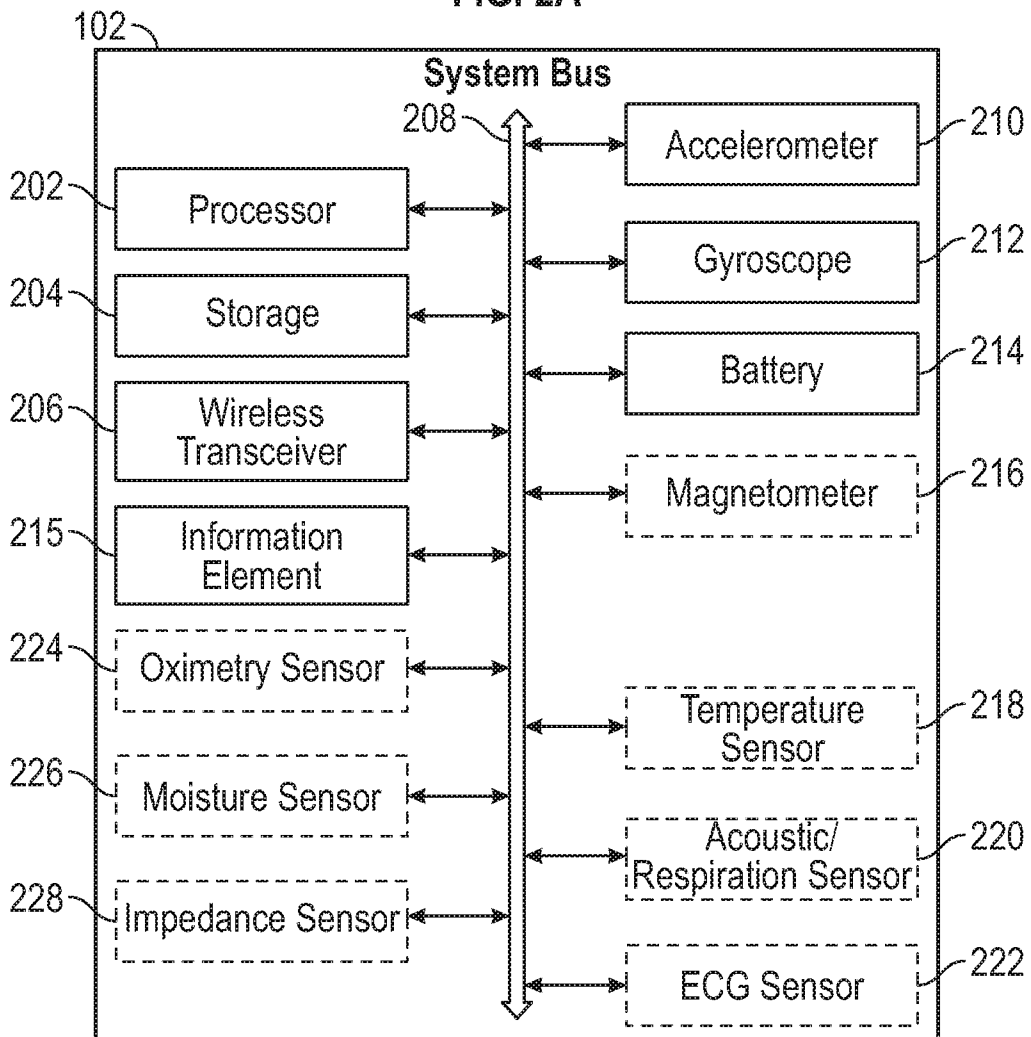

FIG. 2B

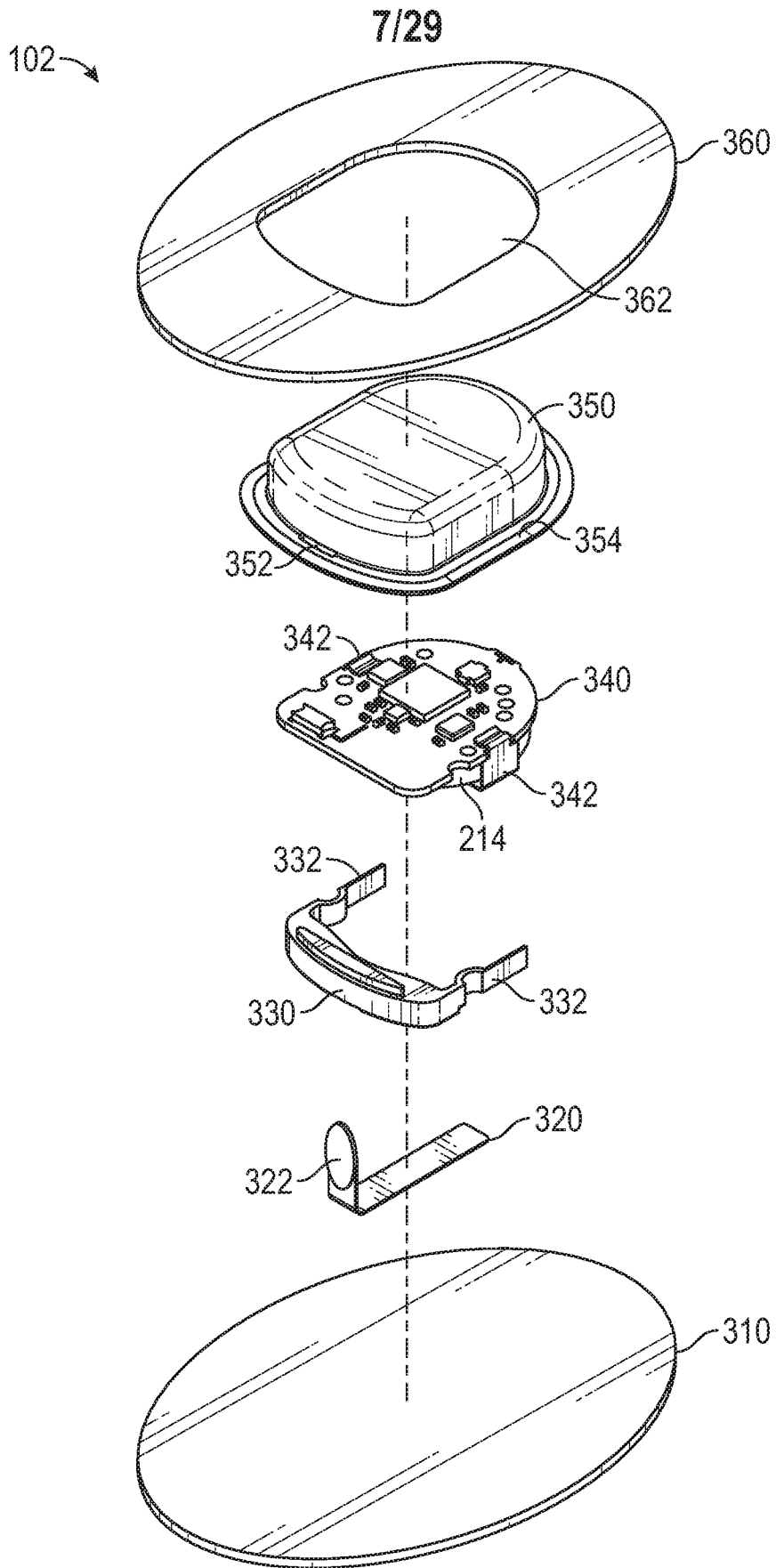

FIG. 3A

8/29

102 →

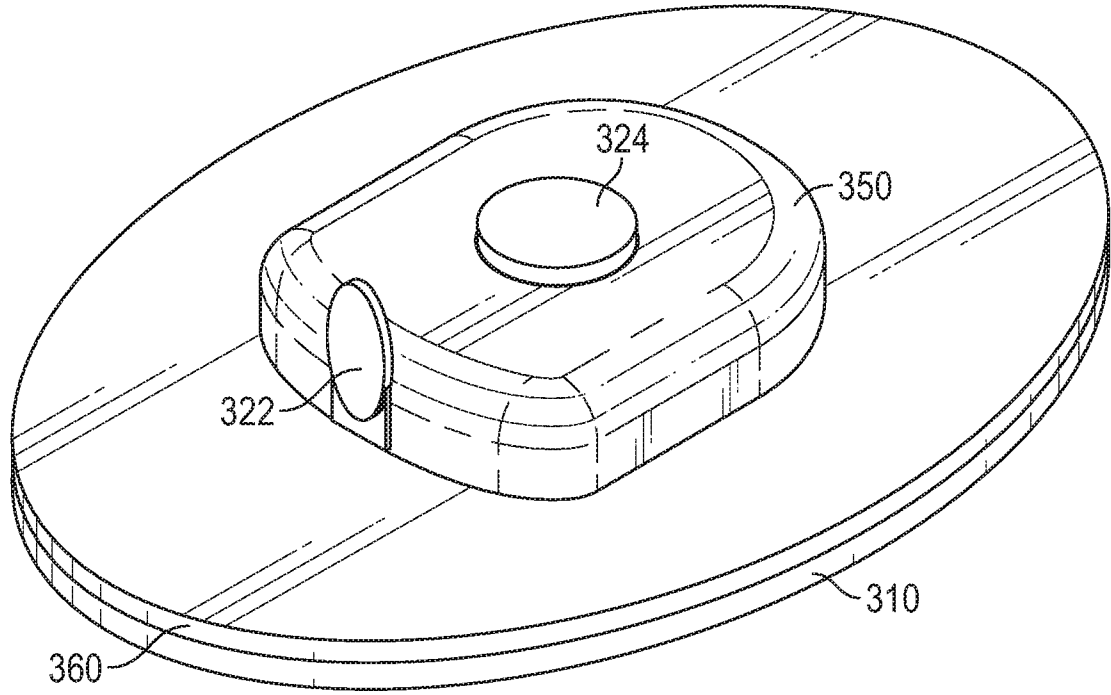

FIG. 3B

102 →

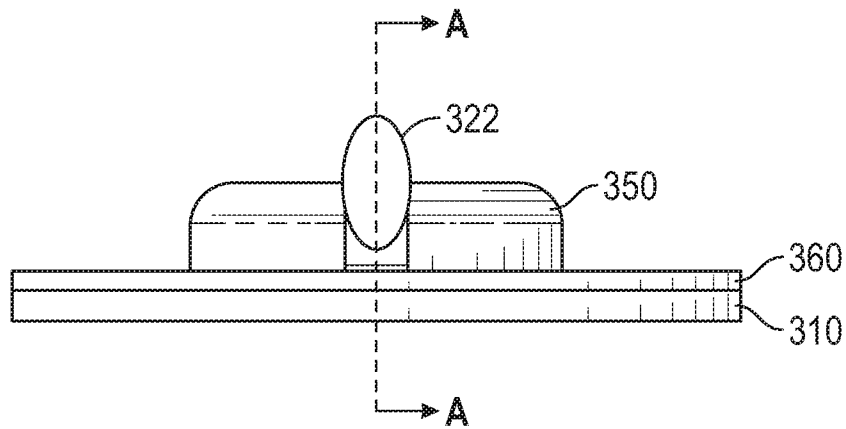

FIG. 3C

9/29

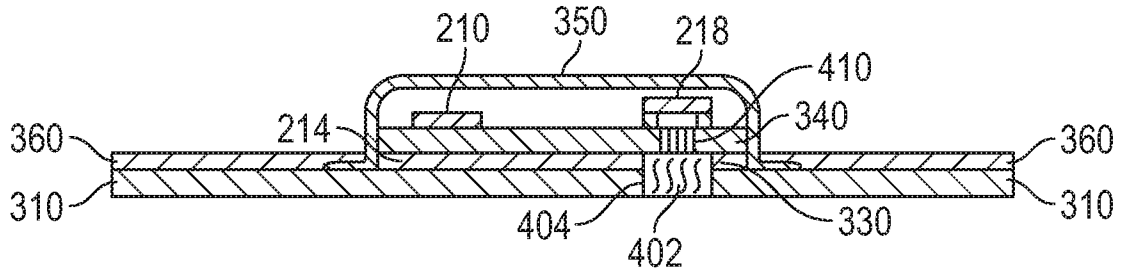

FIG. 4A

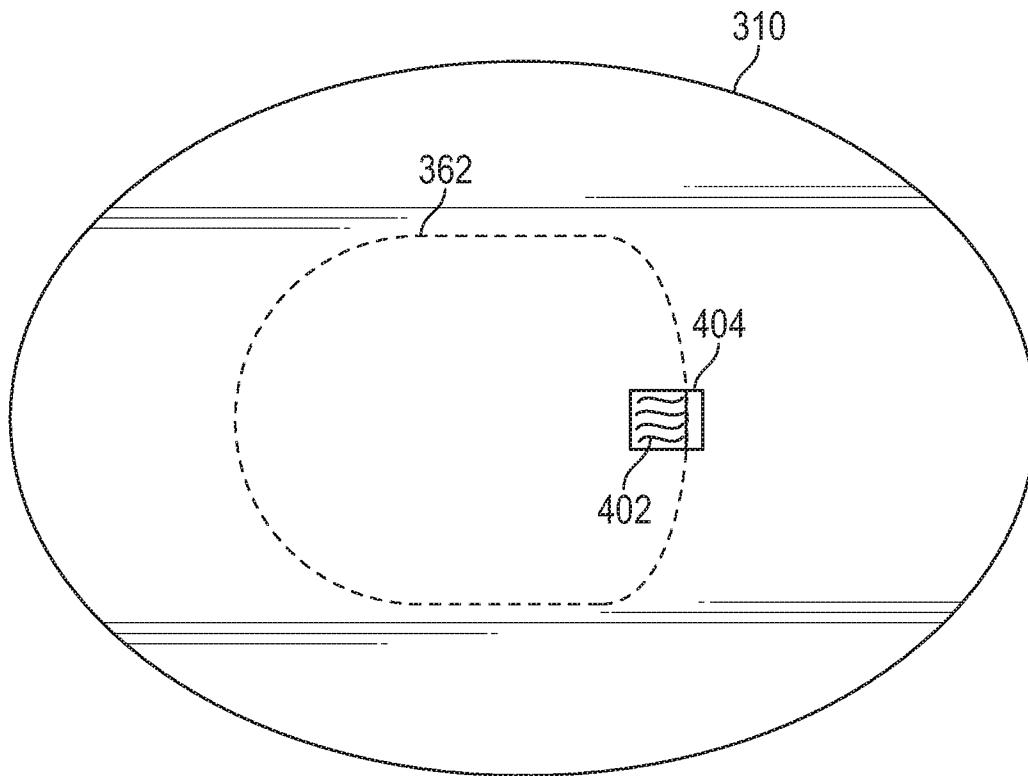

FIG. 4B

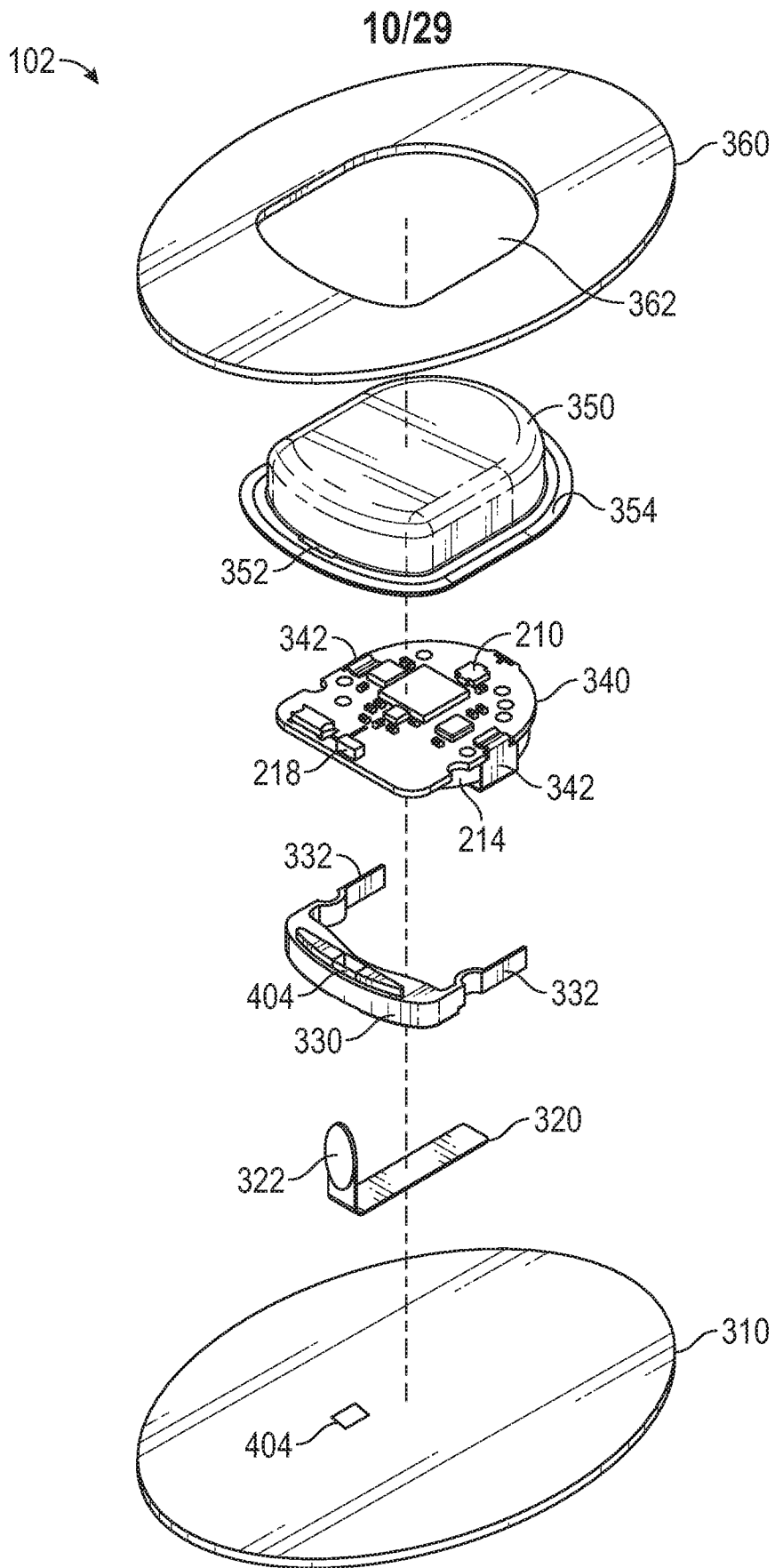

FIG. 4C

11/29

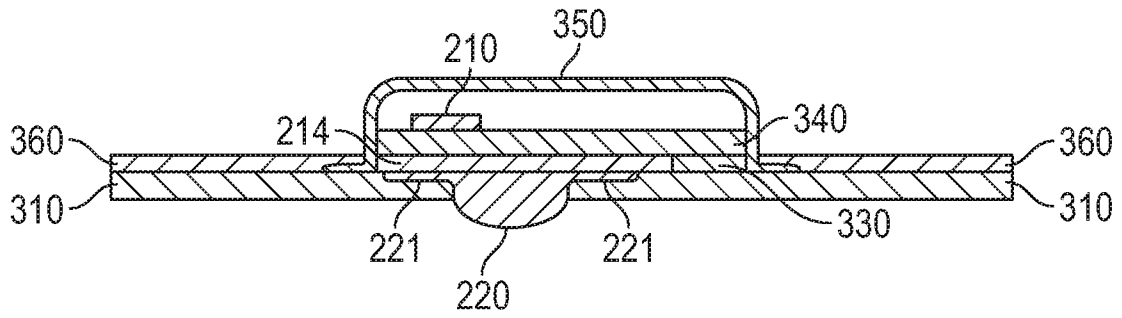

FIG. 5A

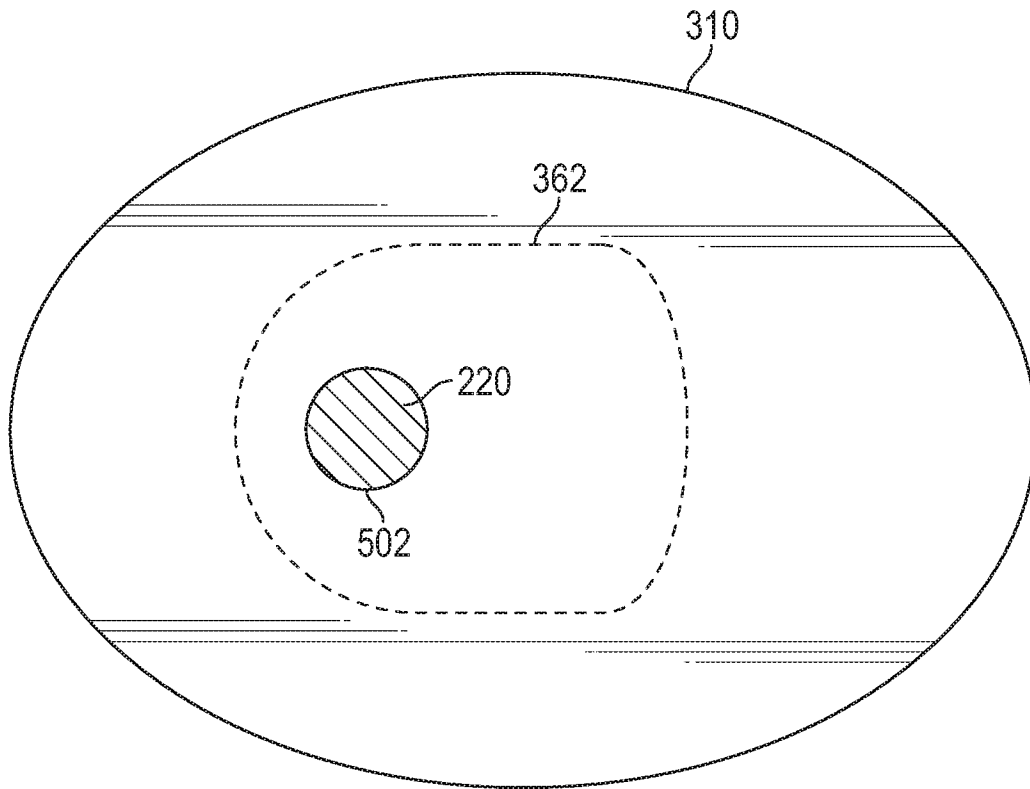

FIG. 5B

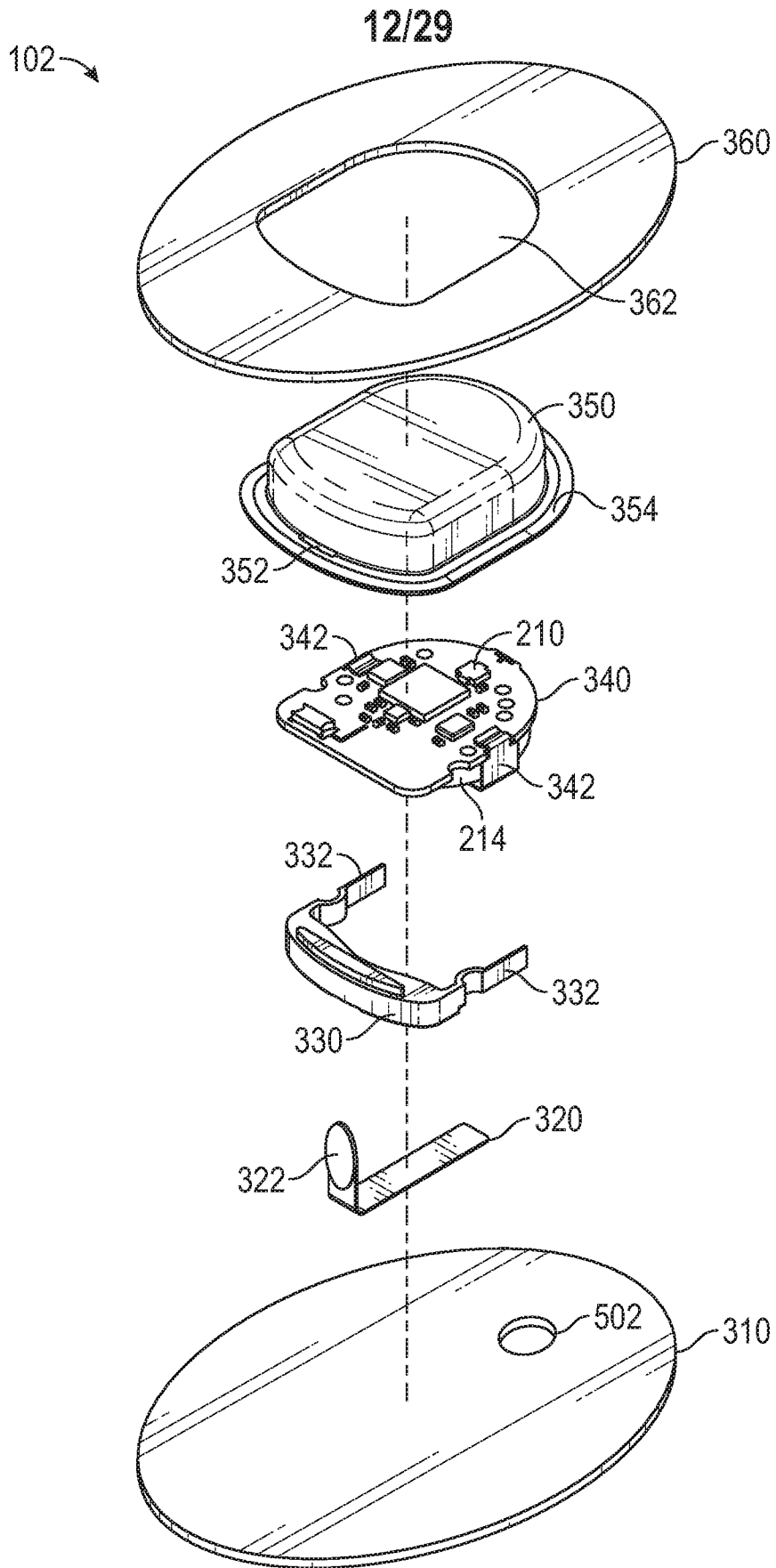

FIG. 5C

13/29

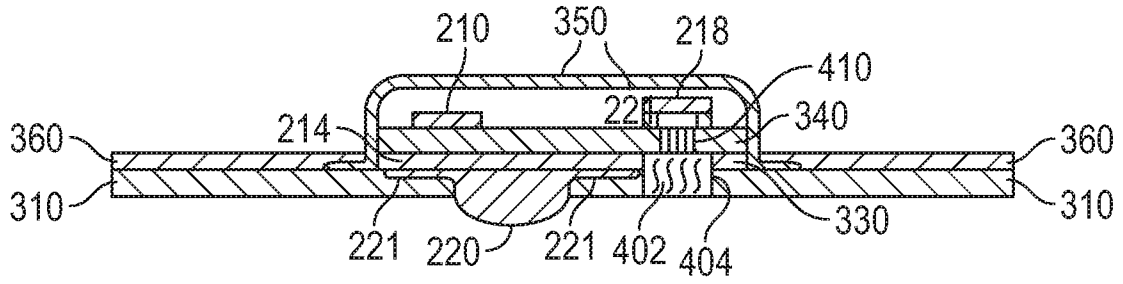

FIG. 6A

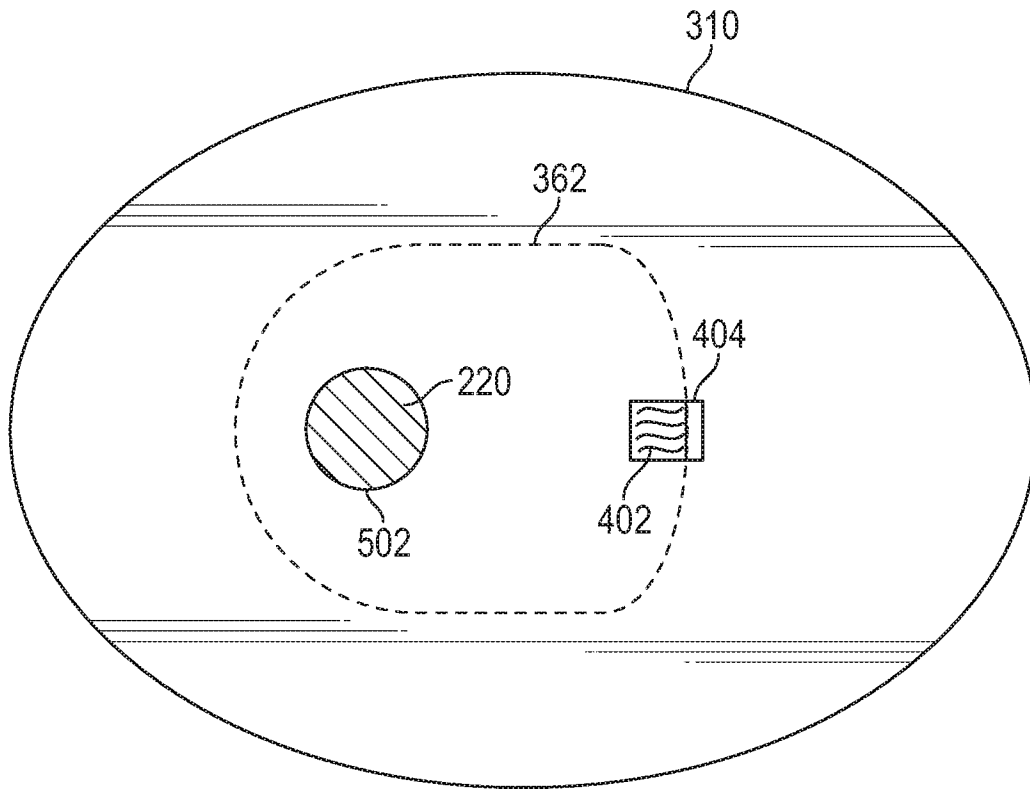

FIG. 6B

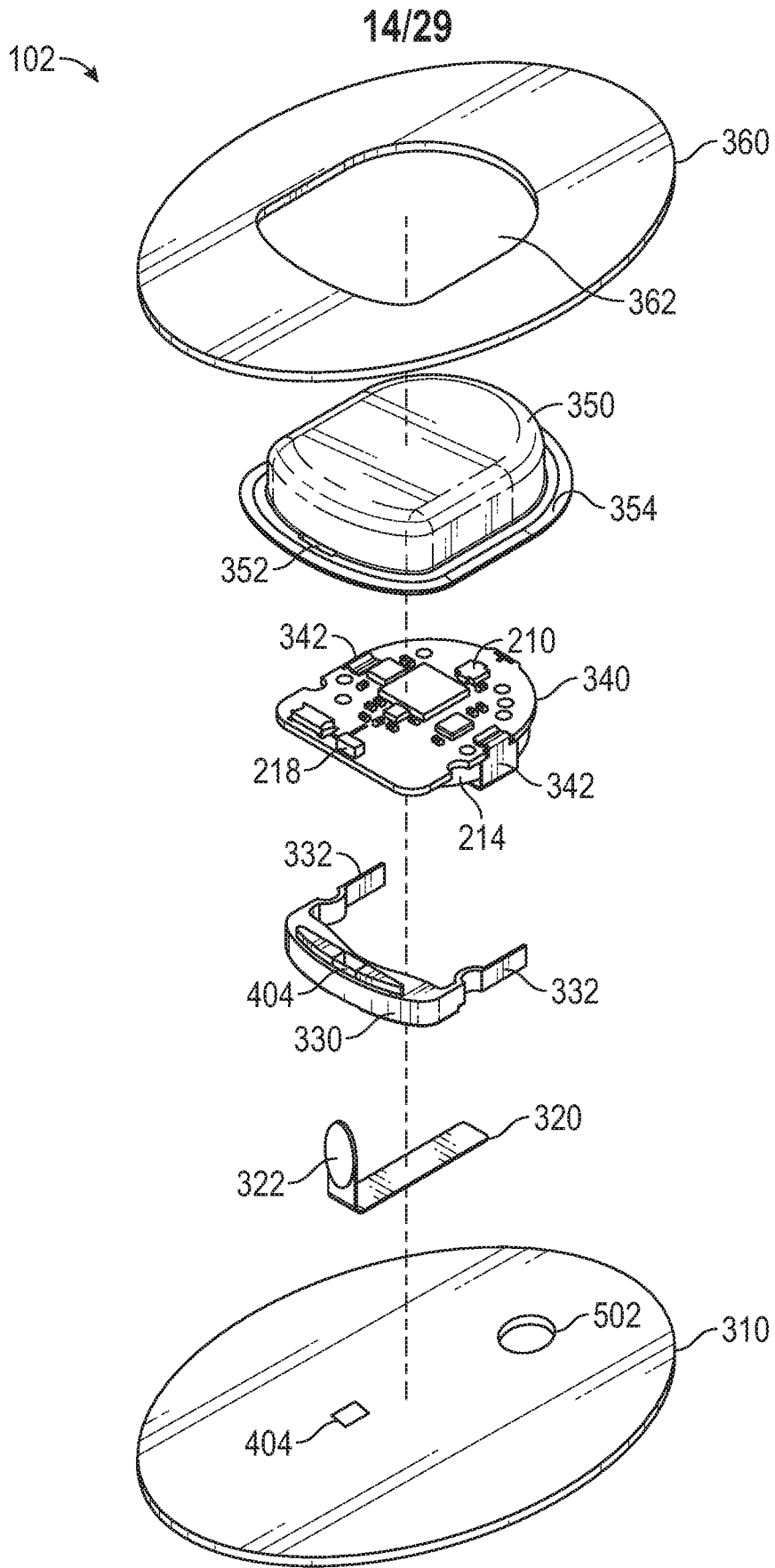

FIG. 6C

15/29

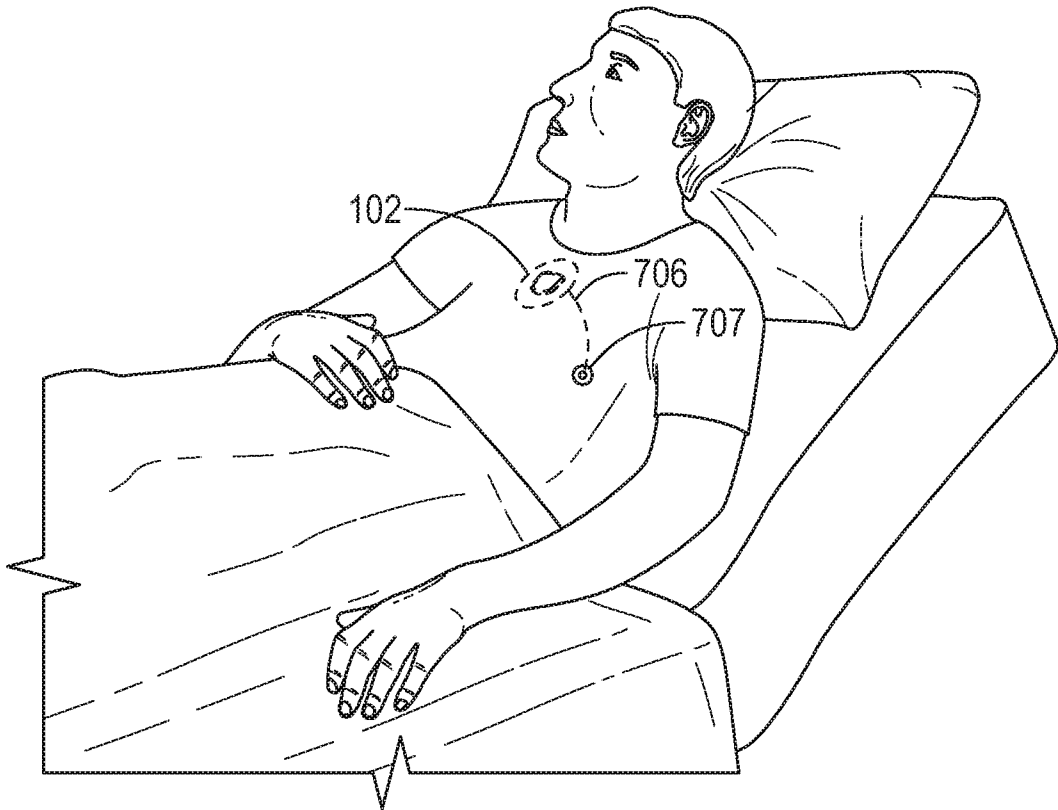

FIG. 7A

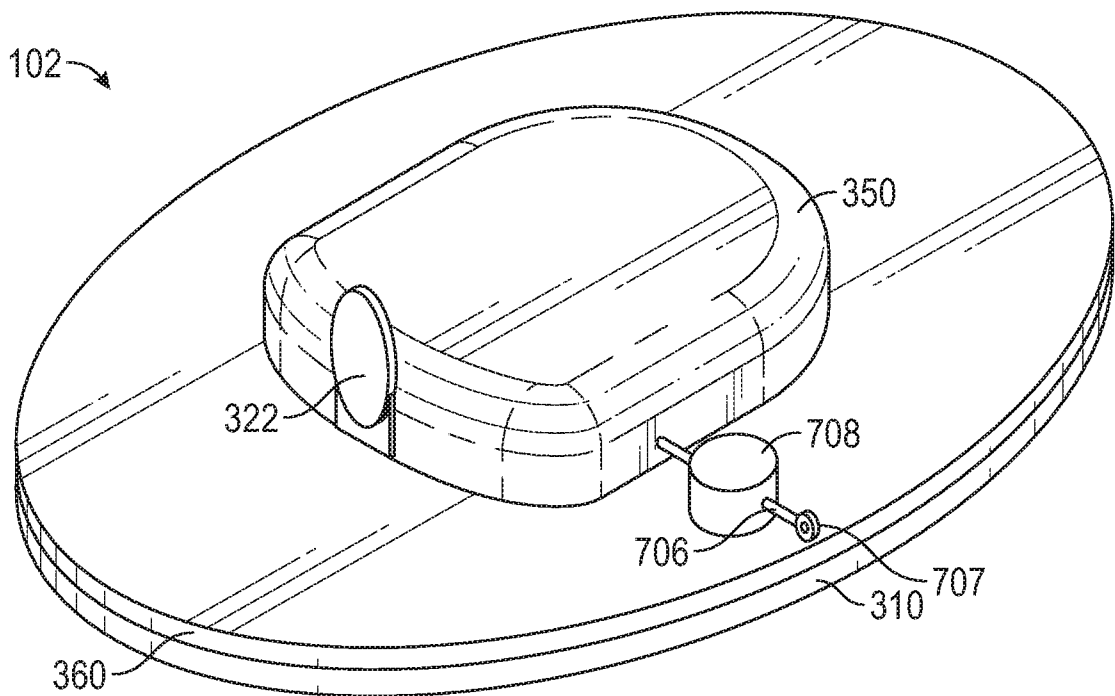

FIG. 7B

16/29

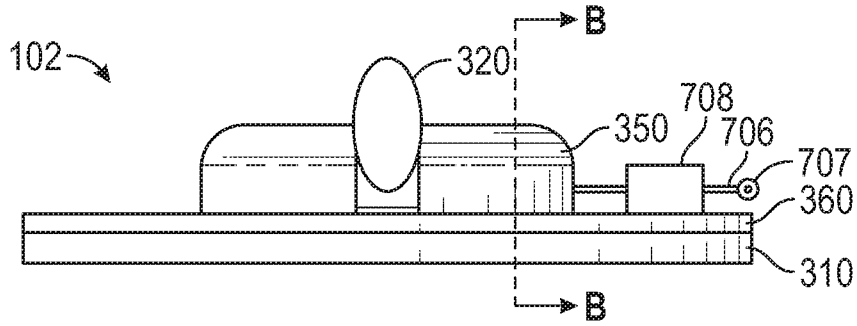

FIG. 7C

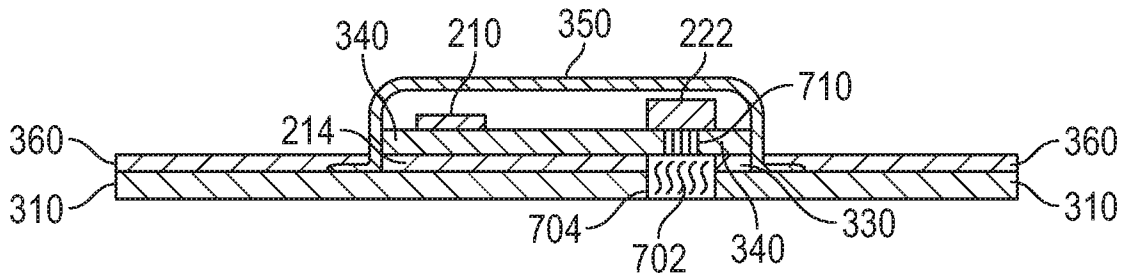

FIG. 7D

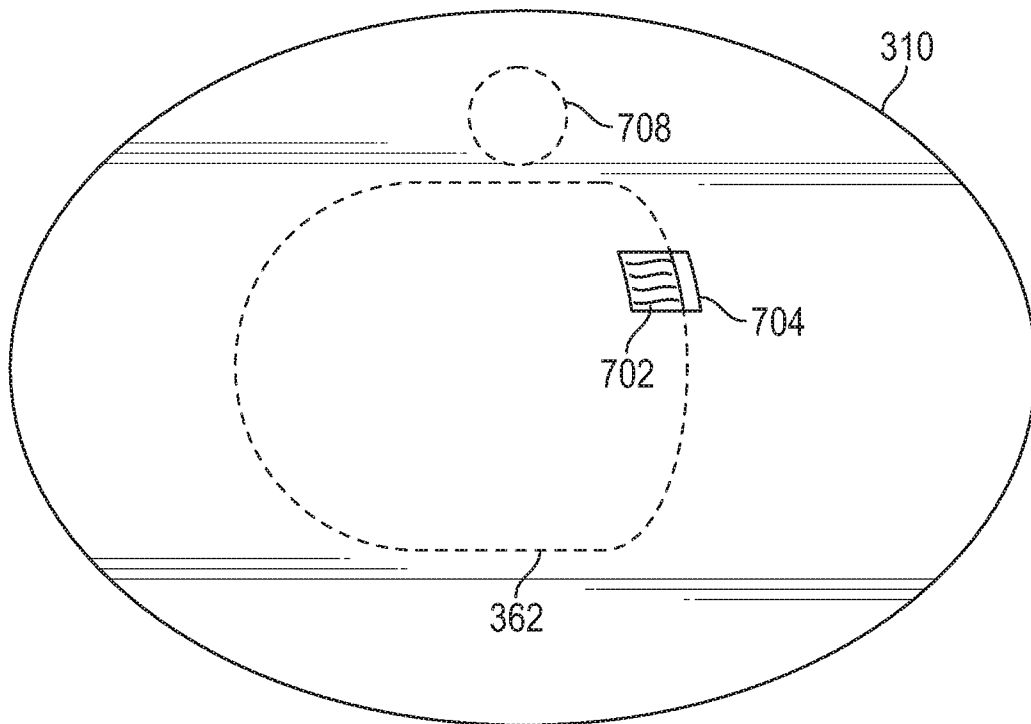

FIG. 7E

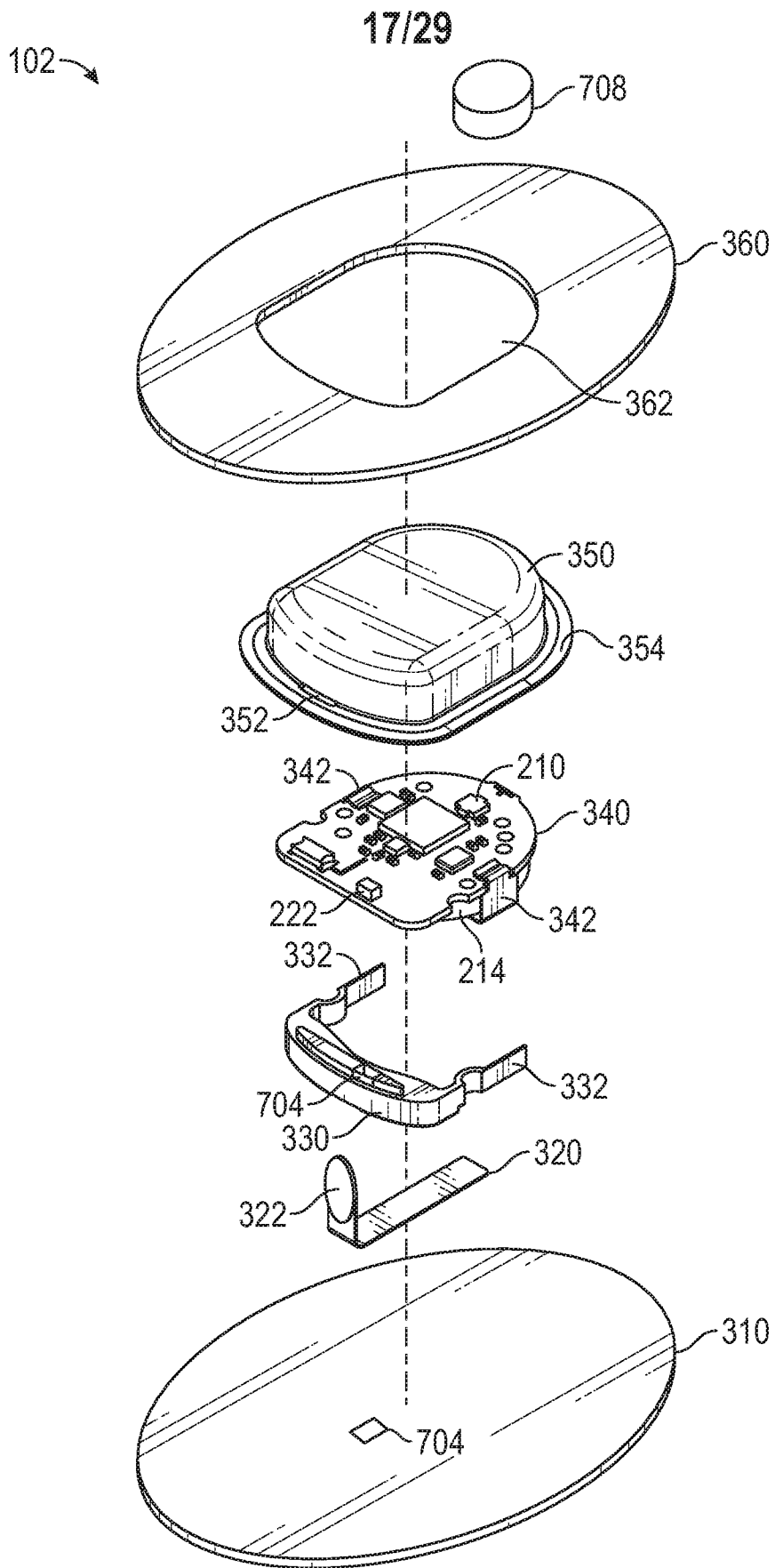

FIG. 7F

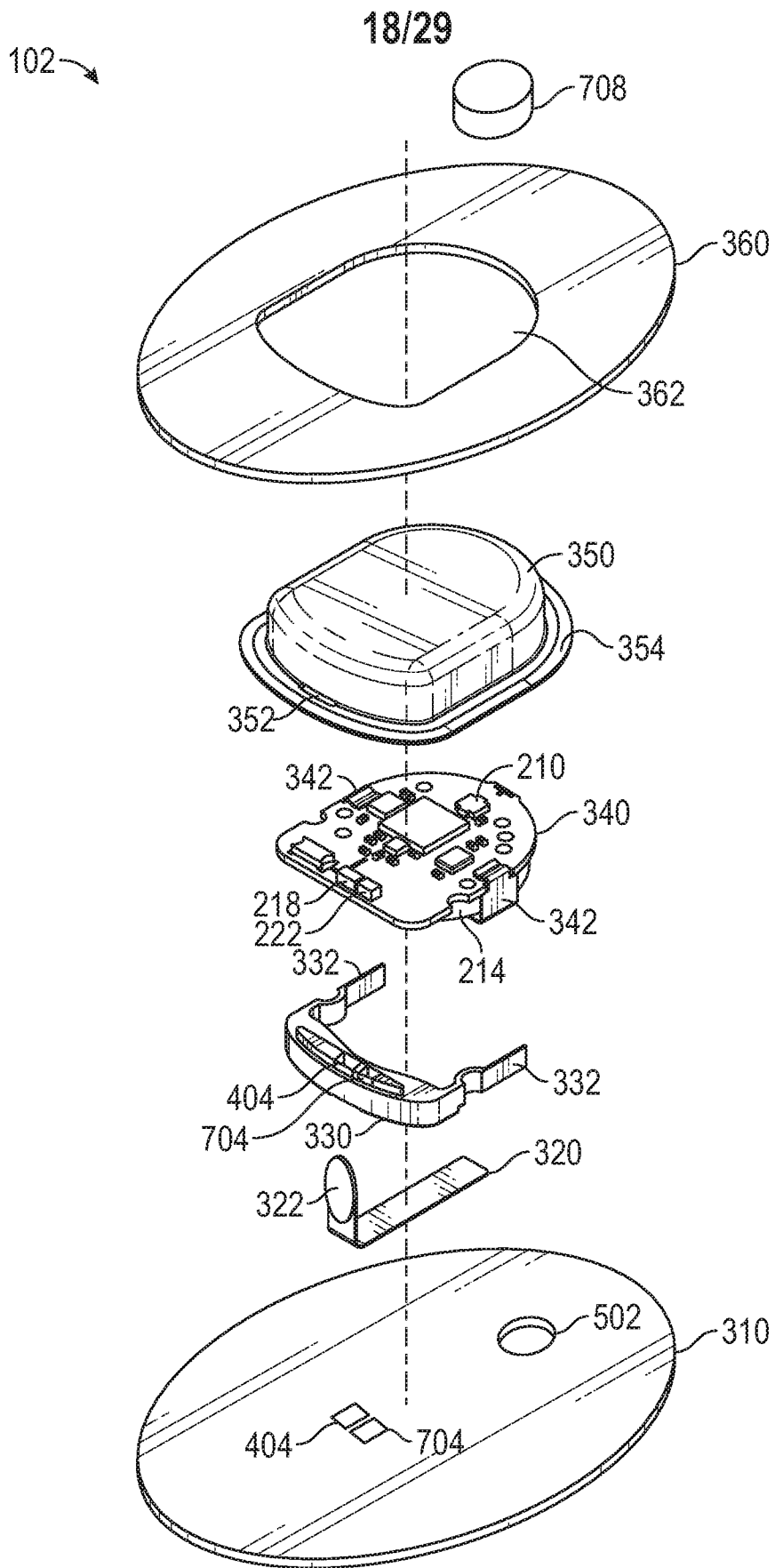

FIG. 8A

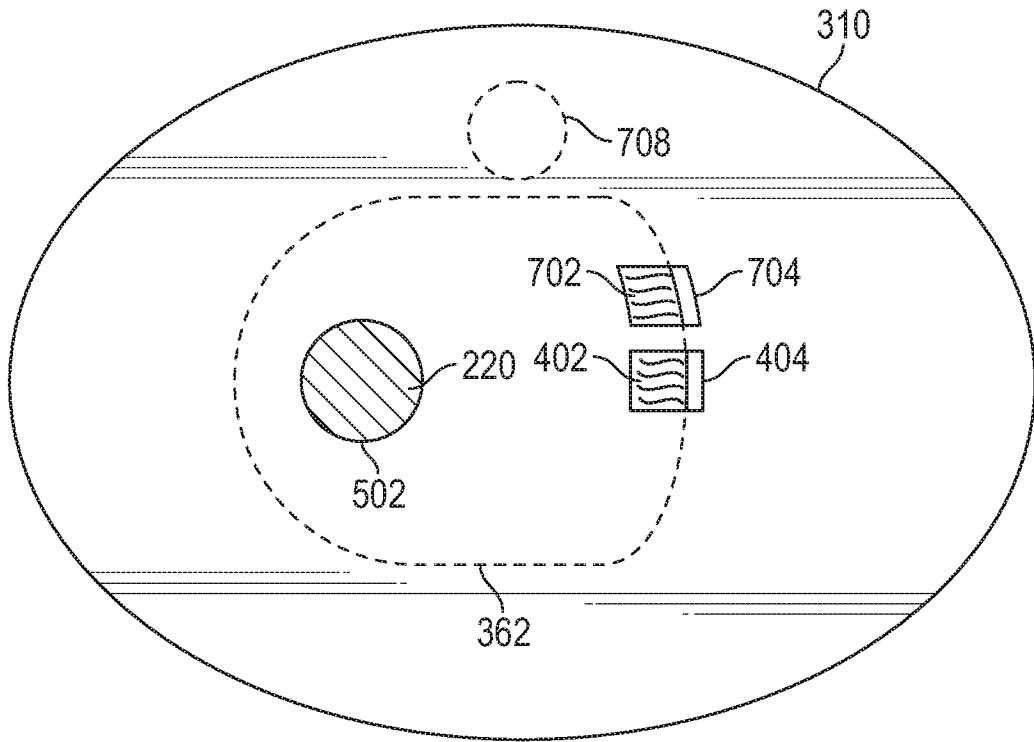

FIG. 8B

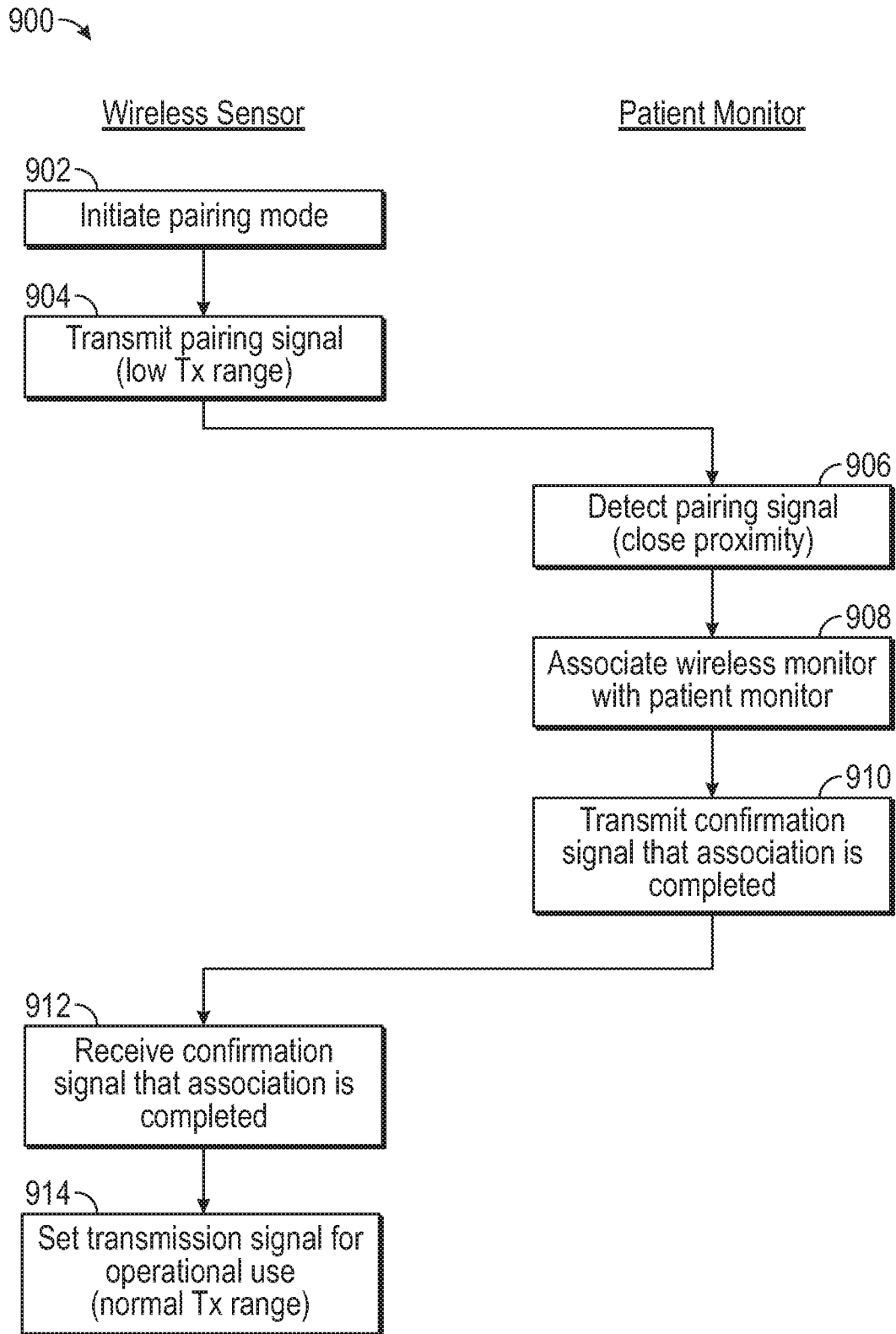

FIG.9

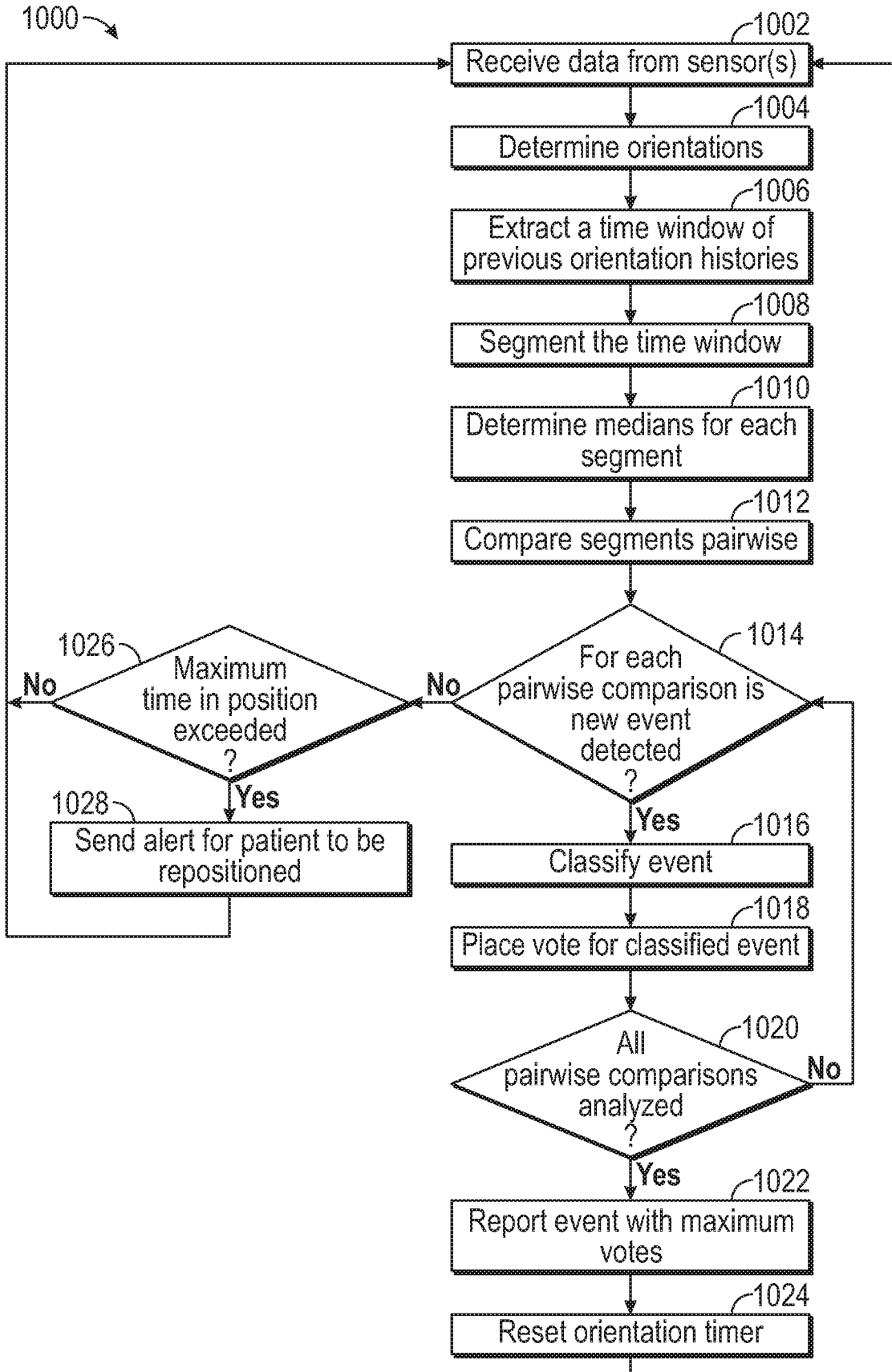

FIG. 10

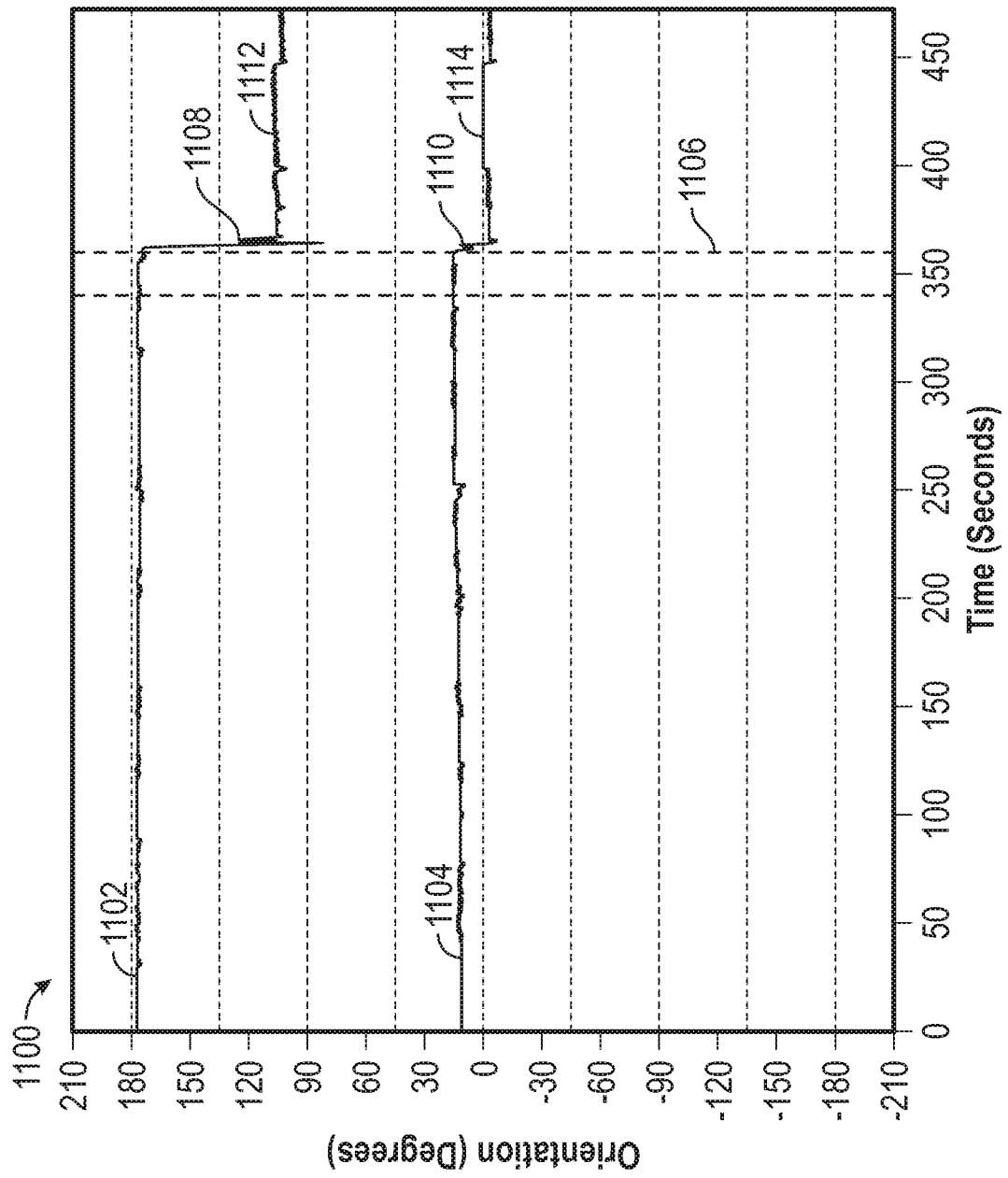

FIG.11A

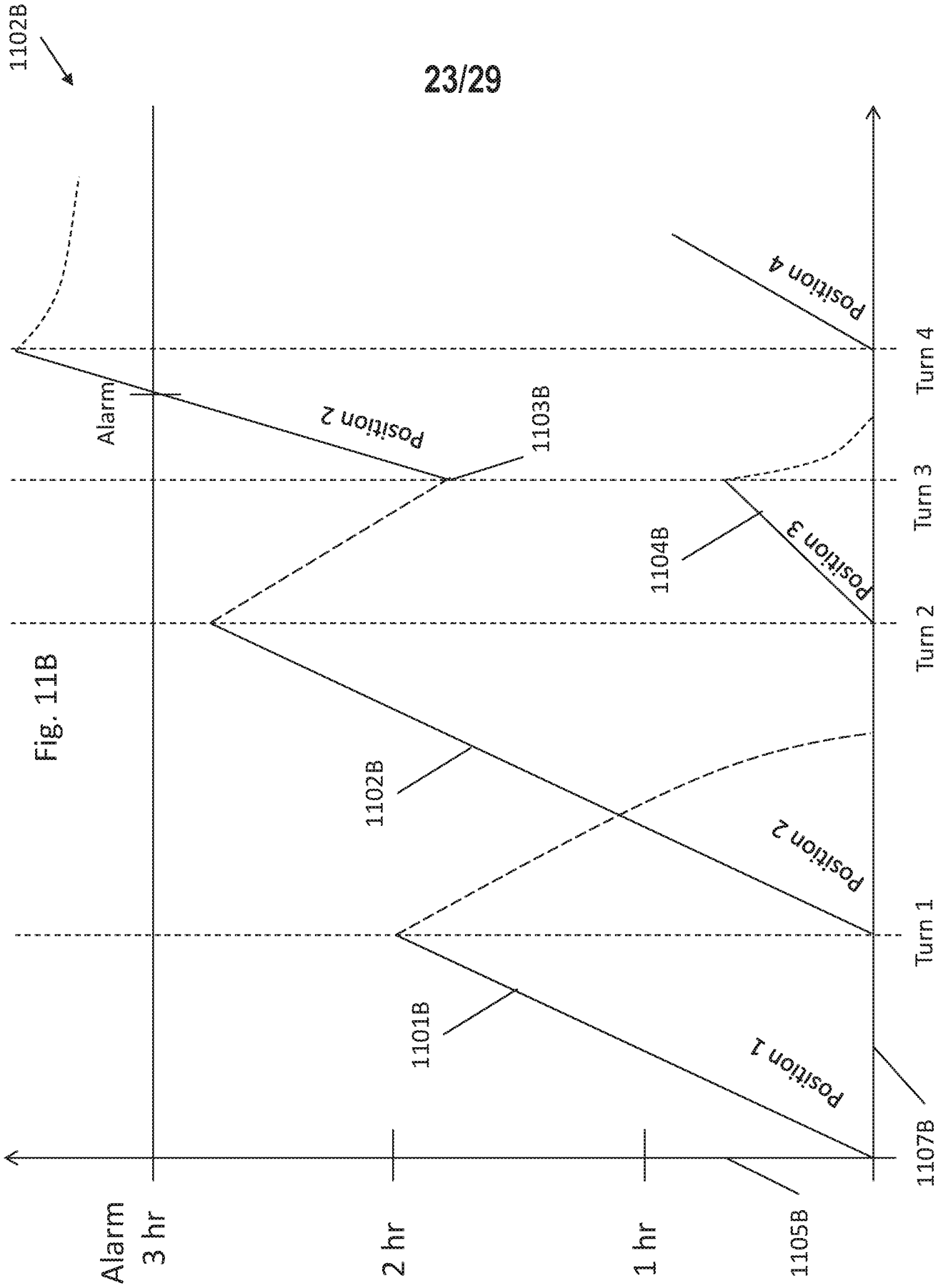

Fig. 11B

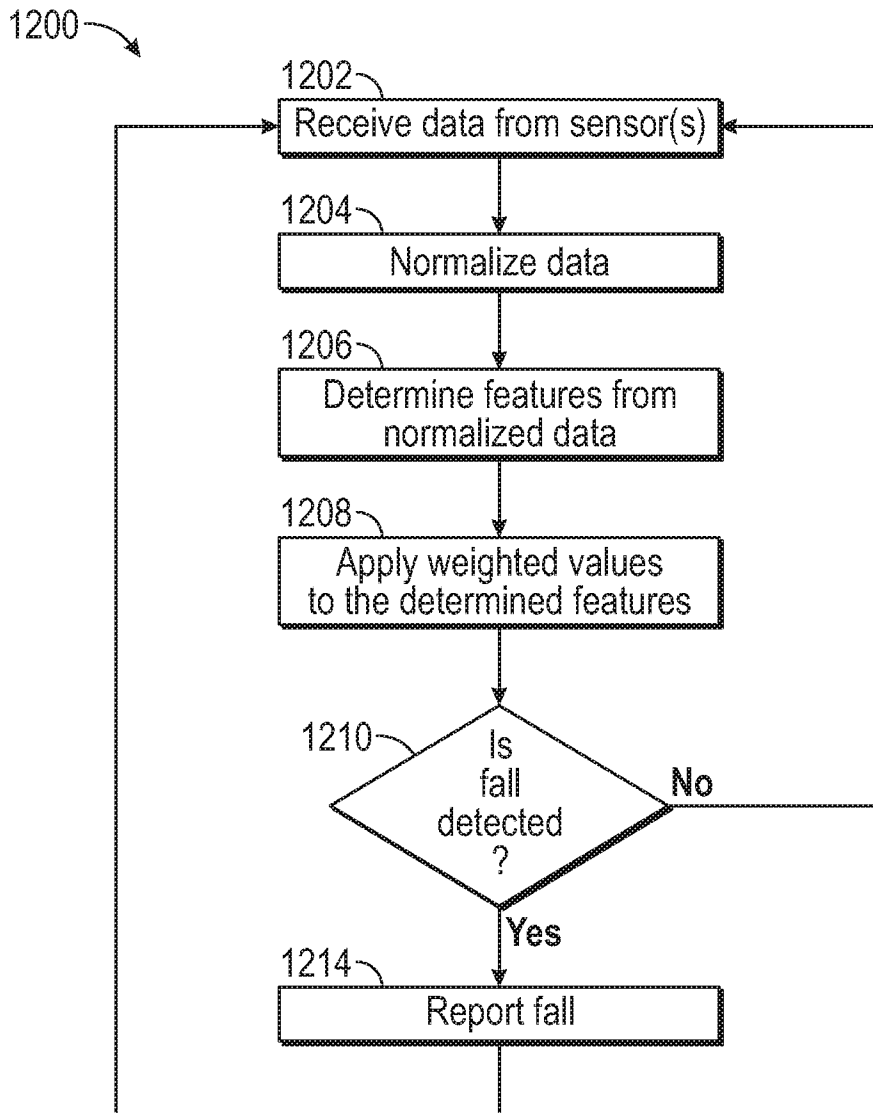

FIG.12

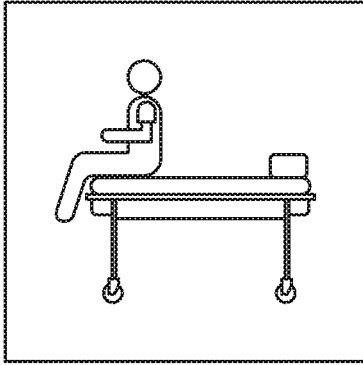

FIG. 13A

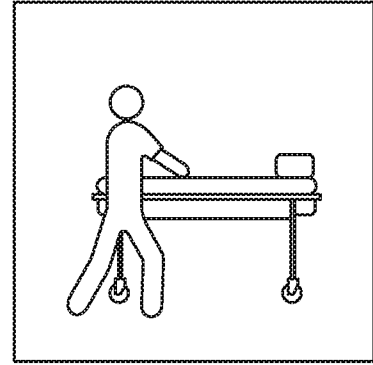

FIG. 13B

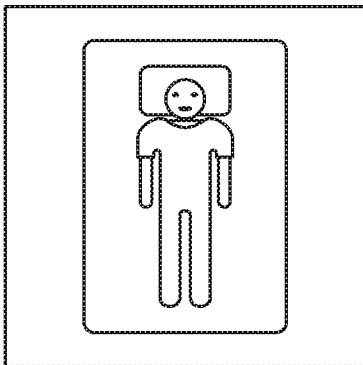

FIG. 13C

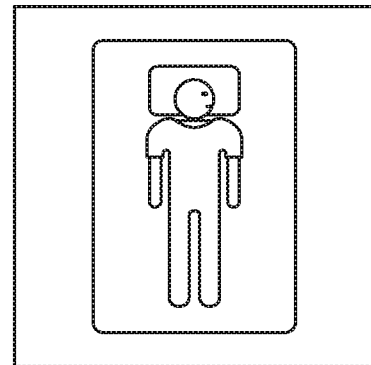

FIG. 13D

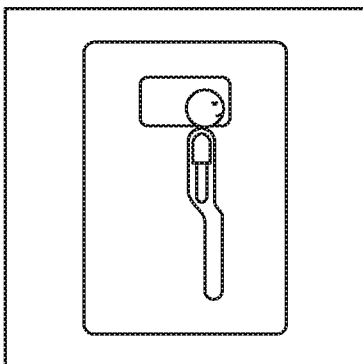

FIG. 13E

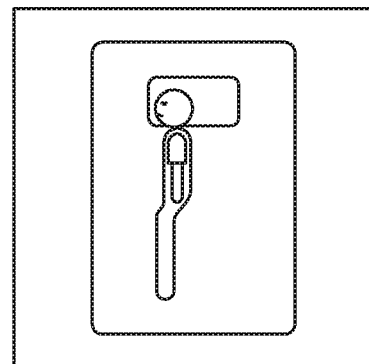

FIG. 13F

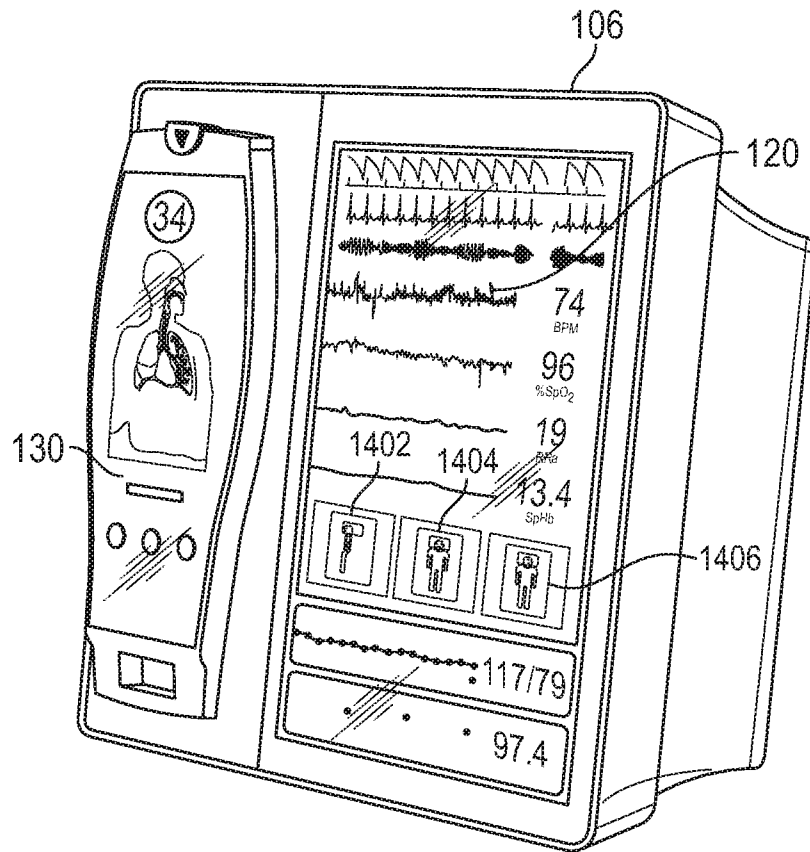

FIG. 14

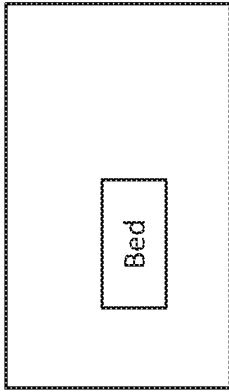

Fig. 15A

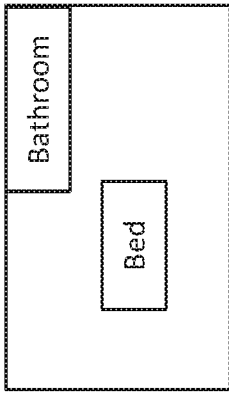

Fig. 15E

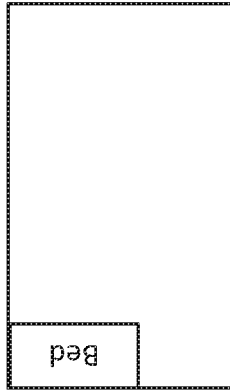

Fig. 15B



Fig. 15F

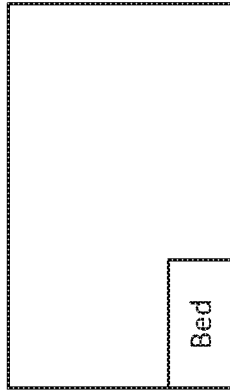

Fig. 15C

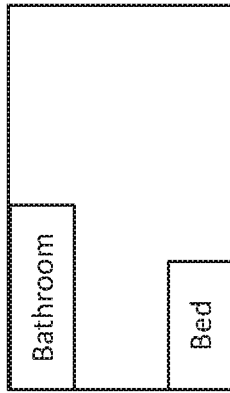

Fig. 15G

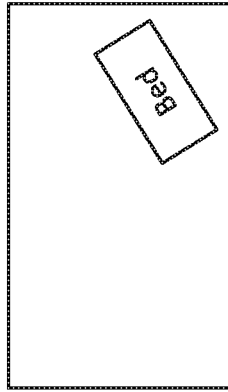

Fig. 15D

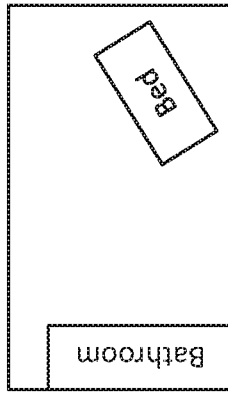

Fig. 15H

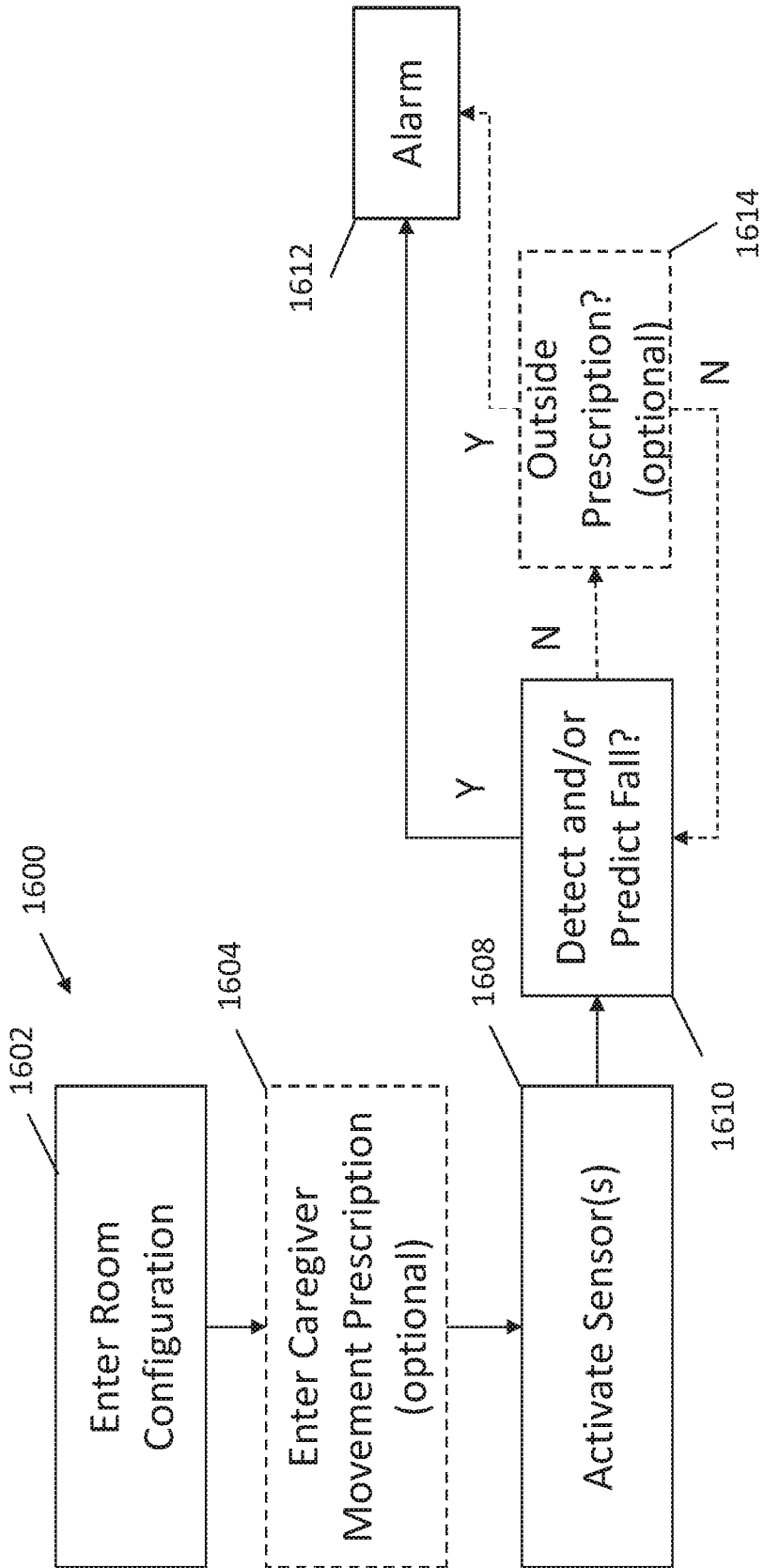

Fig. 16

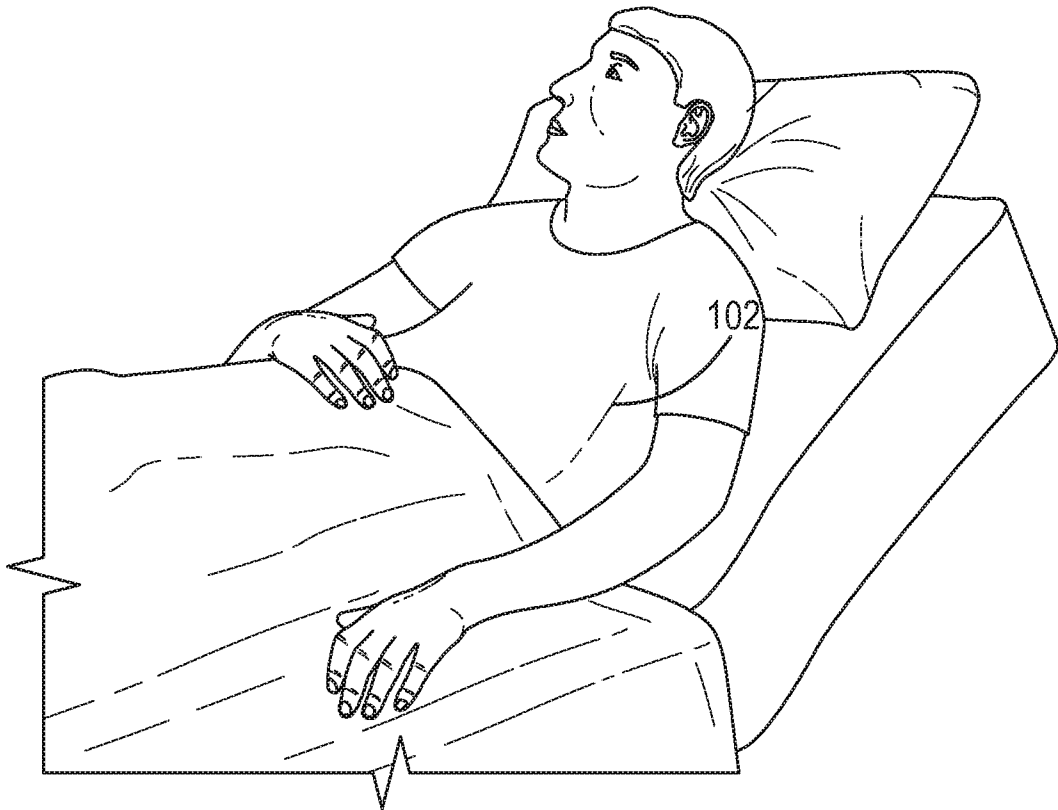

FIG. 17A

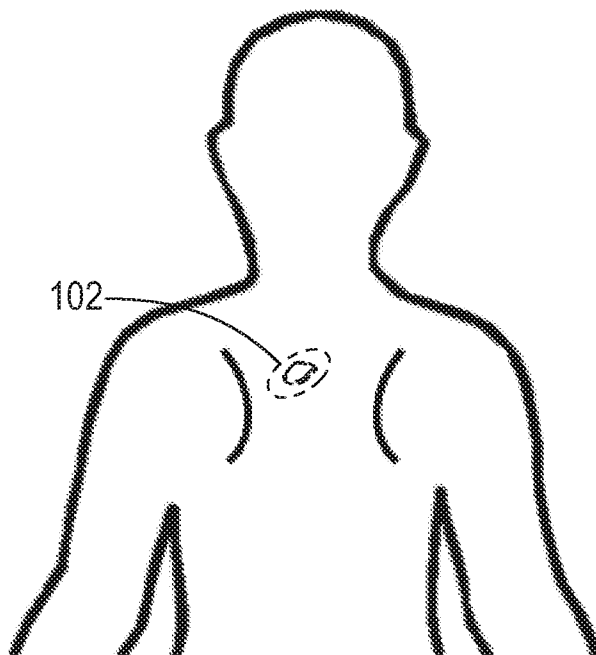

FIG. 17B

**INTERNATIONAL SEARCH REPORT**

International application No  
PCT/US2017/056405

**A. CLASSIFICATION OF SUBJECT MATTER**  
 INV. A61B5/00  
 ADD. A61B5/11

According to International Patent Classification (IPC) or to both national classification and IPC

**B. FIELDS SEARCHED**

Minimum documentation searched (classification system followed by classification symbols)  
 A61B G08B G06F

Documentation searched other than minimum documentation to the extent that such documents are included in the fields searched

Electronic data base consulted during the international search (name of data base and, where practicable, search terms used)  
 EPO-Internal, WPI Data

**C. DOCUMENTS CONSIDERED TO BE RELEVANT**

Category*	Citation of document, with indication, where appropriate, of the relevant passages	Relevant to claim No.
X	US 2016/256080 A1 (SHEN DANIEL Z [US] ET AL) 8 September 2016 (2016-09-08) paragraphs [0013], [0018], [0028], [0033], [0064] - [0071], [0080], [0085], [0153] - [0158], [0192]; figure 3	1-10, 12-14
X	US 2015/272481 A1 (GLASER FRANK [US] ET AL) 1 October 2015 (2015-10-01) paragraphs [0003], [0004], [0019] - [0022], [0028], [0033] - [0035], [0044], [0094]	1,11-13
X	US 2016/228050 A1 (SUGLA BINAY [US] ET AL) 11 August 2016 (2016-08-11) paragraphs [0004], [0005], [0011], [0017], [0018], [0065] - [0067], [0115] figure 13	1

Further documents are listed in the continuation of Box C.

See patent family annex.

\* Special categories of cited documents :

- "A" document defining the general state of the art which is not considered to be of particular relevance
- "E" earlier application or patent but published on or after the international filing date
- "L" document which may throw doubts on priority claim(s) or which is cited to establish the publication date of another citation or other special reason (as specified)
- "O" document referring to an oral disclosure, use, exhibition or other means
- "P" document published prior to the international filing date but later than the priority date claimed

- "T" later document published after the international filing date or priority date and not in conflict with the application but cited to understand the principle or theory underlying the invention
- "X" document of particular relevance; the claimed invention cannot be considered novel or cannot be considered to involve an inventive step when the document is taken alone
- "Y" document of particular relevance; the claimed invention cannot be considered to involve an inventive step when the document is combined with one or more other such documents, such combination being obvious to a person skilled in the art
- "&" document member of the same patent family

Date of the actual completion of the international search  
  
 19 January 2018

Date of mailing of the international search report  
  
 26/01/2018

Name and mailing address of the ISA/  
 European Patent Office, P.B. 5818 Patentlaan 2  
 NL - 2280 HV Rijswijk  
 Tel. (+31-70) 340-2040,  
 Fax: (+31-70) 340-3016

Authorized officer  
  
 Kowalczyk, Szczepan

# INTERNATIONAL SEARCH REPORT

Information on patent family members

International application No

PCT/US2017/056405

Patent document cited in search report	Publication date	Patent family member(s)	Publication date
US 2016256080	A1	08-09-2016	NONE
-----			
US 2015272481	A1	01-10-2015	US 2015272481 A1 01-10-2015
		WO 2015153676 A1	08-10-2015
-----			
US 2016228050	A1	11-08-2016	NONE
-----			

专利名称(译)	用于患者跌倒检测的系统和方法		
公开(公告)号	<a href="#">EP3525661A1</a>	公开(公告)日	2019-08-21
申请号	EP2017791253	申请日	2017-10-12
[标]申请(专利权)人(译)	梅西莫股份有限公司		
申请(专利权)人(译)	Masimo公司		
当前申请(专利权)人(译)	Masimo公司		
[标]发明人	LEE SUNG UK AL ALI AMMAR KASHIF FAISAL USMAN MOHAMMAD KIANI MASSI JOE E		
发明人	LEE, SUNG, UK AL-ALI, AMMAR KASHIF, FAISAL USMAN, MOHAMMAD KIANI, MASSI JOE E.		
IPC分类号	A61B5/00 A61B5/11		
CPC分类号	A61B5/1115 A61B5/1117 A61B5/447 A61B5/4833 A61B5/6823 A61B2562/0219 A61B5/0024 A61B5/1113 A61B5/6887 A61G7/057 G06F19/3418		
优先权	62/407935 2016-10-13 US		
外部链接	<a href="#">Espacenet</a>		

#### 摘要(译)

公开了一种患者监测系统，以帮助管理有摔倒风险的患者。该系统包括患者佩戴的无线传感器，其可以固定到患者的背部，其感测患者的运动并且将指示所感测的运作的信息无线地发送到患者监视器。患者监视器接收，存储和处理所传输的信息以确定患者是否已经跌倒或即将跌倒。在这种检测时，系统可以通知患者的看护者患者已经跌倒或即将跌倒，因此需要立即注意。