

(19) World Intellectual Property Organization
International Bureau



(43) International Publication Date
9 September 2005 (09.09.2005)

PCT

(10) International Publication Number
WO 2005/082239 A1

- (51) International Patent Classification⁷: **A61B 5/00**
- (21) International Application Number: PCT/US2005/006207
- (22) International Filing Date: 25 February 2005 (25.02.2005)
- (25) Filing Language: English
- (26) Publication Language: English
- (30) Priority Data: 10/787,852 25 February 2004 (25.02.2004) US
- (71) Applicant (for all designated States except US): **NELL-COR PURITAN BENNETT INCORPORATED** [US/US]; 4280 Hacienda Drive, Pleasanton, CA 94588 (US).
- (72) Inventors; and
- (75) Inventors/Applicants (for US only): **CHEW, Bradford, B.** [US/US]; 805 Springbrook Drive, San Ramon, CA 94583 (US). **PETERSEN, Ethan** [US/US]; 18968 Thornbury Avenue, Castro Valley, CA 94546 (US). **SHEA, William** [US/US]; 4049 Findlay Way, Livermore, CA 94550 (US).
- (74) Agents: **SLAYDEN, Bruce, W., II et al.**; Baker Botts L.L.P., 1500 San Jacinto Center, 98 San Jacinto Boulevard, Austin, TX 78701-4039 (US).
- (81) Designated States (unless otherwise indicated, for every kind of national protection available): AE, AG, AL, AM, AT, AU, AZ, BA, BB, BG, BR, BW, BY, BZ, CA, CH, CN, CO, CR, CU, CZ, DE, DK, DM, DZ, EC, EE, EG, ES, FI, GB, GD, GE, GH, GM, HR, HU, ID, IL, IN, IS, JP, KE, KG, KP, KR, KZ, LC, LK, LR, LS, LT, LU, LV, MA, MD, MG, MK, MN, MW, MX, MZ, NA, NI, NO, NZ, OM, PG, PH, PL, PT, RO, RU, SC, SD, SE, SG, SK, SL, SM, SY, TJ, TM, TN, TR, TT, TZ, UA, UG, US, UZ, VC, VN, YU, ZA, ZM, ZW.
- (84) Designated States (unless otherwise indicated, for every kind of regional protection available): ARIPO (BW, GH, GM, KE, LS, MW, MZ, NA, SD, SL, SZ, TZ, UG, ZM, ZW), Eurasian (AM, AZ, BY, KG, KZ, MD, RU, TJ, TM), European (AT, BE, BG, CH, CY, CZ, DE, DK, EE, ES, FI, FR, GB, GR, HU, IE, IS, IT, LT, LU, MC, NL, PL, PT, RO, SE, SI, SK, TR), OAPI (BF, BJ, CF, CG, CI, CM, GA, GN, GQ, GW, ML, MR, NE, SN, TD, TG).

[Continued on next page]

(54) Title: SWITCH-MODE OXIMETER LED DRIVE WITH A SINGLE INDUCTOR

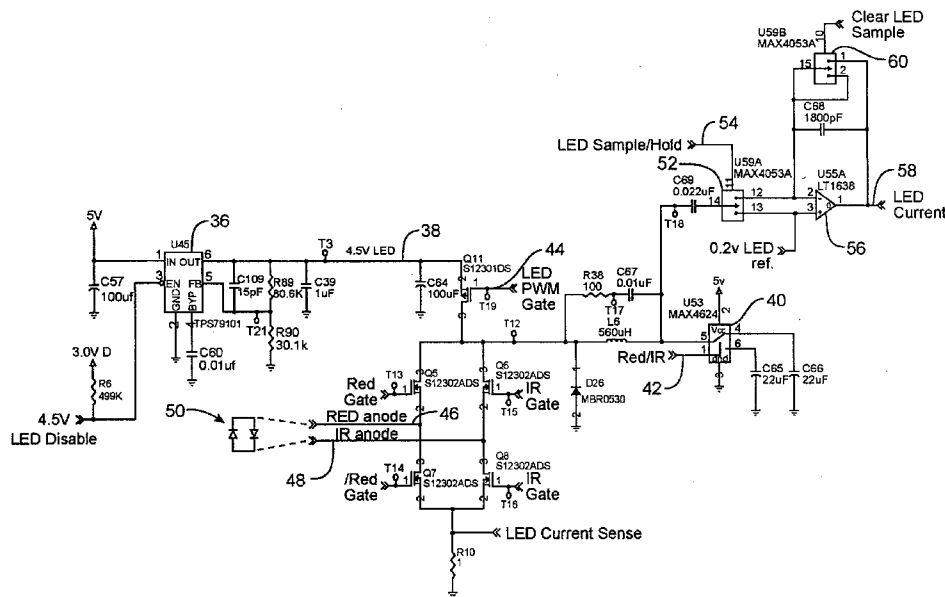

(57) Abstract: A light emitter drive circuit for an oximeter which utilizes a single inductor (L6) for driving multiple light emitters (50). The inductor is connected to a switching circuit (40) to multiple energy storage circuits, such as capacitors. These are alternately charged up, using the same inductor. Subsequently, the capacitors are alternately discharged for their corresponding light emitters through the same inductor. Also, the magnetic susceptibility of the LED drive circuit is reduced by using magnetic flux canceling in the inductor. In one embodiment, a toroidal inductor is used with geometric symmetry and its magnetic flux. In another embodiment, a dual core closed bobbin shielded inductor is used.

WO 2005/082239 A1

**Declaration under Rule 4.17:**

- as to applicant's entitlement to apply for and be granted a patent (Rule 4.17(ii)) for the following designations AE, AG, AL, AM, AT, AU, AZ, BA, BB, BG, BR, BW, BY, BZ, CA, CH, CN, CO, CR, CU, CZ, DE, DK, DM, DZ, EC, EE, EG, ES, FI, GB, GD, GE, GH, GM, HR, HU, ID, IL, IN, IS, JP, KE, KG, KP, KR, KZ, LC, LK, LR, LS, LT, LU, LV, MA, MD, MG, MK, MN, MW, MX, MZ, NA, NI, NO, NZ, OM, PG, PH, PL, PT, RO, RU, SC, SD, SE, SG, SK, SL, SM, SY, TJ, TM, TN, TR, TT, TZ, UA, UG, UZ, VC, VN, YU, ZA, ZM, ZW, ARIPO patent (BW, GH, GM, KE, LS, MW, MZ, NA, SD, SL, SZ, TZ, UG, ZM, ZW), Eurasian patent (AM, AZ, BY, KG, KZ, MD, RU, TJ, TM), European patent (AT, BE, BG, CH, CY, CZ, DE, DK, EE, ES, FI, FR, GB, GR,

HU, IE, IS, IT, LT, LU, MC, NL, PL, PT, RO, SE, SI, SK, TR), OAPI patent (BF, BJ, CF, CG, CI, CM, GA, GN, GQ, GW, ML, MR, NE, SN, TD, TG)

Published:

- with international search report
— before the expiration of the time limit for amending the claims and to be republished in the event of receipt of amendments

For two-letter codes and other abbreviations, refer to the "Guidance Notes on Codes and Abbreviations" appearing at the beginning of each regular issue of the PCT Gazette.

SWITCH-MODE OXIMETER LED DRIVE WITH A SINGLE INDUCTOR

BACKGROUND OF THE INVENTION

[0001] The present invention relates to oximeters, and in particular to LED drive circuits in pulse oximeters.

[0002] Pulse oximetry is typically used to measure various blood chemistry characteristics including, but not limited to, the blood-oxygen saturation of hemoglobin in arterial blood, the volume of individual blood pulsations supplying the tissue, and the rate of blood pulsations corresponding to each heartbeat of a patient. Measurement of these characteristics has been accomplished by use of a non-invasive sensor which scatters light through a portion of the patient's tissue where blood perfuses the tissue, and photoelectrically senses the absorption of light in such tissue. The amount of light absorbed at various wavelengths is then used to calculate the amount of blood constituent being measured.

[0003] The light scattered through the tissue is selected to be of one or more wavelengths that are absorbed by the blood in an amount representative of the amount of the blood constituent present in the blood. The amount of transmitted light scattered through the tissue will vary in accordance with the changing amount of blood constituent in the tissue and the related light absorption. For measuring blood oxygen level, such sensors have typically been provided with a light source that is adapted to generate light of at least two different wavelengths, and with photodetectors sensitive to both of those wavelengths, in accordance with known techniques for measuring blood oxygen saturation.

[0004] Known non-invasive sensors include devices that are secured to a portion of the body, such as a finger, an ear or the scalp. In animals and humans, the tissue of these body portions is perfused with blood and the tissue surface is readily accessible to the sensor.

[0005] The light sources, typically light emitting diodes (LEDs), need to be driven with current to activate them. Because of the significant amount of current required, this can interfere with reducing power consumed by an oximeter. One solution is shown in U.S. Patent No. 6,226,539. There, an inductor and capacitor circuit is used to first store charge in a first switch position, and then subsequently, in a second switch position, deliver that stored

charge to the LED. Two different inductor and capacitor circuits are used, one for each LED. It would be desirable to reduce the number of components required in the circuit of this patent.

BRIEF SUMMARY OF THE INVENTION

[0006] The present invention provides a light emitter drive circuit for an oximeter which utilizes a single inductor for driving multiple light emitters. The inductor is connected through a switching circuit to multiple energy storage circuits, such as capacitors. These are alternately charged up, using the same inductor. Subsequently, the capacitors are alternately discharged to activate their corresponding light emitters through the same inductor.

[0007] In another aspect of the present invention, the magnetic susceptibility of the LED drive circuit is reduced by using magnetic flux canceling in the inductor. In one embodiment, a toroidal inductor is used with geometric symmetry in its magnetic flux. In another embodiment, a dual core closed bobbin shielded inductor is used. This embodiment has windings of both cores in series that are used to cancel the effect of an external magnetic field.

[0008] For a further understanding of the nature and advantages of the present invention, reference should be made to the following description taken in conjunction with the accompanying drawings.

BRIEF DESCRIPTION OF THE DRAWINGS

[0009] Fig. 1 is a block diagram of an oximeter incorporating the present invention.

[0010] Fig. 2 is a circuit diagram of a LED drive circuit according to an embodiment of the present invention.

[0011] Fig. 3 is a block diagram of one embodiment of the logic for generating the timing and control signals for the circuit of Fig.2.

[0012] Fig. 4 is a diagram of a toroidal inductor used in one embodiment of the present invention.

[0013] Figs. 5 and 6 are diagrams of a dual core inductor according to an embodiment of the present invention.

DETAILED DESCRIPTION OF THE INVENTION

Oximeter system

[0014] Fig. 1 illustrates an embodiment of an oximetry system incorporating the present invention. A sensor 10 includes red and infrared LEDs and a photodetector. These are connected by a cable 12 to a board 14. LED drive current is provided by an LED drive interface 16. The received photocurrent from the sensor is provided to an I-V interface 18. The IR and red voltages are then provided to a sigma-delta interface 20 incorporating the present invention. The output of sigma-delta interface 20 is provided to a microcontroller 22. Microcontroller 22 includes flash memory for a program, and SRAM memory for data. The processor also includes a microprocessor chip 24 connected to a flash memory 26. Finally, a clock 28 is used and an interface 30 to a digital calibration in the sensor 10 is provided. A separate host 32 receives the processed information, as well as receiving an analog signal on a line 34 for providing an analog display.

LED Drive Circuit

[0015] Fig. 2 is a circuit diagram of the LED drive circuit according to an embodiment of the invention, which forms a portion of LED drive interface 16 of Fig. 1. A voltage regulator 36 provides a voltage separate from the voltage supply for the overall oximeter circuitry. The output is provided as a 4.5 volt signal on line 38, with the level being set by the feedback resistor divider of resistors R89 and R90. The voltage on line 38 is provided to a FET transistor Q11 to an inductor L6. The current through inductor L6 is provided by a switch 40 to one of capacitors C65 and C66, which store charge for the red and IR LEDs, respectively. A red/IR control signal on line 42 selects the switch position under control of the oximeter processor. A control signal LED PWM gate on line 44 controls the switching of transistor switch Q11.

[0016] Once the capacitors are charged up, the control signal on line 44 turns off switch Q11 and current is provided from either capacitor C65 or C66, through switch 40 and inductor L6 to either the red anode line 46 or the IR anode line 48 by way of transistors Q5 and Q6, respectively. A signal "red gate" turns on transistor Q5, while its inverse, "/red gate" turns off transistor Q7. This provides current through the red anode line 46 to the back to back LEDs 50, with the current returning through the IR anode to transistor Q8 and through resistor R10 to ground. Transistor Q8 is turned on by the signal "/IR gate" while the inverse

of this signal, "IR gate" turns off transistor Q6. The signals are reversed when the IR anode is to be driven, with the "IR gate" and "red gate" signals, and their inverses, changing state, so that current is provided through transistor Q6 to IR anode 48 and returns through red anode 46 and through transistor Q7 to resistor R10 and ground. The "LED current sense" signal is read for calibration purposes not relevant to the present invention.

[0017] When the current from the capacitor C65 or C66 is provided through inductor L6 to the LEDs, and that current is switched off at the desired time, transistor Q11 is turned on so that the remaining current during the transition can be dumped into capacitor C64. This addresses the fact that the FET transistor switching is not instantaneous. Subsequently, C64 will dump its current through Q11 and inductor L6 into the capacitors when they are recharged.

[0018] Resistor R38 and capacitor C67 are connected in parallel to inductor L6 to protect against signal spikes, and provide a smooth transition. Connected to inductor L6 is a sampling circuit with a switch 52 controlled by an LED sample hold signal on line 54 to sample the signals and provide them through an amplifier 56 to a "LED current" signal on line 58 which is read by the processor. Operational amplifier 56 operates between 4.5 volts and ground. Thus, a voltage reference slightly above ground, of 0.2 volts, is provided as a voltage reference on pin 3. An integrating capacitor C68 is provided in parallel to amplifier 56. A switch 60 responds to a "clear LED sample" signal to operate the switch to short out the capacitor between samples.

[0019] The sample and hold circuit measures the voltage at node T18, between capacitor C69 and inductor L6, to determine the current. Capacitor C69 is 1/1000 of the value of capacitors C65 and C66. Thus, a proportional current is provided through C69, which is injected through switch 52 to integrating capacitor C68 to provide a voltage which can be measured at the output of amplifier 56 on line 58. The voltage measured by the processor on line 58 is used as a feedback, with the processor varying the width of the pulse delivered to transistor Q11 to selectively vary the amount of energy that's delivered to the capacitors 65 and 66, and then is eventually discharged to the LEDs 50. A PI (Proportional Integral) loop inside the processor then controls the PWM signal at Q11. This allows precise control of the LED intensity, allowing it to be maximized, if desired, without exceeding the desired limits (to avoid burning the patient, etc.).

[0020] The lower left of the diagram shows a "4.5 v LED disable" signal which is used by the microprocessor to turn off the voltage regulator 36 in certain instances. For example, diagnostics looking for shorts in a new sensor plugged in will turn off the voltage regulator if there is a problem with the LED line.

[0021] Fig. 3 illustrates processor 22, from Fig. 1, connected to programmed logic 62, which is in the LED drive interface 16 in Fig. 1. Programmed logic 62 provides the different control signals used by the circuit of Fig. 2 in response to basic timing signals from the processor of a clock, a sync pulse, and a pulse width signal.

[0022] Thus, the present invention provides an improvement over the circuit shown in Patent No. 6,226,539 by moving the switch position between the inductor and the capacitors to eliminate the need for two inductors. This not only reduces the part count, requiring only one inductor instead of two, but also provides better matching between the red and IR drive currents since both use the same inductor.

[0023] In another aspect of the invention, the LED drive circuit's susceptibility to magnetic interference is reduced. This magnetic interference can distort the detected pleth waveform. This is minimized by using magnetic flux canceling in the inductor. In one embodiment, this is a toroidal inductor as shown in Fig. 4. The toroidal inductor has a geometric symmetry in its magnetic flux. Another embodiment uses a dual core closed bobbin shielded inductor, such as shown in Figs. 5 and 6. The windings of both cores in series are used to cancel the effect of an external magnetic field. These magnetic flux canceling inductors can be used either in the circuit of Fig. 2, or could be used in the dual inductor embodiment of the prior art. Fig. 5 shows the dual core inductor with a bobbin 70 in a cylinder 72. The wires are wound through gaps 76, as shown in Fig. 6. A first winding 78 is clockwise, while a second winding 80 is counterclockwise. A top view 82 is also shown. Ideally, the combined inductance in one embodiment is 680 uH.

[0024] The invention as illustrated in the embodiment of Fig. 2 enables the multiplexing of current, through an H-bridge topology, to back-to-back LEDs. Alternately, a different number of loads could be provided. The present invention is scalable to N-loads. The present invention provides significant efficiencies through reduction of support components, choice of components, and the properties of "loss-less" capacitor and inductor storage devices. The circuit of Fig. 2 can handle a range of forward voltage drops across the LEDs.

The voltage provided varies automatically in accordance with the LED voltage drop, and does not put out more energy than it needs to.

[0025] The circuit is dynamically controlled through a PI loop in the processor, with current feedback being provided by the capacitive current divider from each storage capacitor (C65 and C66), which provides isolation. The feedback can be calibrated with a traditional in-line sense resistor, R10. In addition, this technique allows adjustment of the peak current for optimal signal-to-noise during the sampling period.

[0026] The addition of the upstream linear regulator 36 enhances power supply rejection capability, while the PI loop provides additional power supply insensitivity (to drift, P-P, surge, etc.).

[0027] As will be appreciated by those with skill in the art, the present invention can be embodied in other specific forms without departing from the essential characteristics thereof. For example, instead of two drive lines, three drive lines could be provided by adding another leg with FET transistor switches connected to the inductor. Additionally, this could be scalable to more than three legs connected in parallel, similar to the leg of Q6, Q8, and the leg of Q5, Q7. Accordingly, the foregoing description is intended to be illustrative, but not limiting, of the scope of the invention which is set forth in the following claims.

WHAT IS CLAIMED IS:

1. A light emitter drive circuit for an oximeter comprising:
a voltage generating circuit;
an inductor coupled to said voltage generating circuit;
a first switching circuit coupled to a first node of said inductor;
first and second energy storage circuits connected to said first switching circuit, such that current from said inductor can be steered by said first switching circuit to one of said energy storage circuits;
a second switching circuit coupled to a second node of said inductor; and
first and second light emitter drive lines connected to said second switching circuit, such that energy from said first and second energy storage circuits can be alternately coupled to said first and second light emitter drive lines.
2. The circuit of claim 1 wherein said first and second energy storage circuits comprise first and second capacitors.
3. The circuit of claim 1 wherein said drive lines are configured to drive light emitters that are back-to-back.
4. The circuit of claim 3 wherein said second switching circuit is an H-bridge drive circuit including four transistors.
5. The circuit of claim 1 wherein said voltage generating circuit is a voltage regulator separate from a supply voltage for a remainder of said oximeter.
6. The circuit of claim 1 further comprising a resistor and a capacitor in parallel with said inductor.
7. The circuit of claim 1 wherein said inductor is a magnetic flux canceling inductor.
8. The circuit of claim 7 wherein said inductor is a toroidal inductor.
9. The circuit of claim 7 wherein said inductor is a dual core closed bobbin shielded inductor.

10. The circuit of claim 1 further comprising a sample and hold circuit connected to said second node of said inductor.

11. The circuit of claim 1 further comprising at least a third energy storage circuit.

12. An LED circuit for an oximeter comprising:
a voltage generating circuit;
an inductor coupled to said voltage generating circuit;
a first switching circuit coupled to a first node of said inductor;
first and second capacitors connected to said first switching circuit, such that current from said inductor can be steered by said first switching circuit to one of said capacitors;

an H-bridge drive switching circuit including four transistors coupled to a second node of said inductor; and

first and second light emitter drive lines, for LEDs in a back-to-back configuration, in the middle of said H-bridge, such that energy from said first and second capacitors can be alternately coupled to said first and second light emitter drive lines.

13. A light emitter drive circuit for an oximeter comprising:
a voltage generating circuit;
first and second energy storage circuits;
a magnetic flux canceling inductor coupled to said voltage generating circuit and at least one of said energy storage circuits; and

switching circuitry configured to first steer current into said energy storage circuits, and then provide energy from said first and second energy storage circuits to drive lines for light emitters.

14. The circuit of claim 12 wherein said inductor is a toroidal inductor.

15. The circuit of claim 12 wherein said inductor is a dual core closed bobbin shielded inductor.

10. The circuit of claim 1 further comprising a sample and hold circuit connected to said second node of said inductor.

11. The circuit of claim 1 further comprising at least a third energy storage circuit.

12. An LED circuit for an oximeter comprising:
a voltage generating circuit;
an inductor coupled to said voltage generating circuit;
a first switching circuit coupled to a first node of said inductor;
first and second capacitors connected to said first switching circuit, such that current from said inductor can be steered by said first switching circuit to one of said capacitors;

an H-bridge drive switching circuit including four transistors coupled to a second node of said inductor; and

first and second light emitter drive lines, for LEDs in a back-to-back configuration, in the middle of said H-bridge, such that energy from said first and second capacitors can be alternately coupled to said first and second light emitter drive lines.

13. A light emitter drive circuit for an oximeter comprising:
a voltage generating circuit;
first and second energy storage circuits;
a magnetic flux canceling inductor coupled to said voltage generating circuit and at least one of said energy storage circuits; and

switching circuitry configured to first steer current into said energy storage circuits, and then provide energy from said first and second energy storage circuits to drive lines for light emitters.

14. The circuit of claim 12 wherein said inductor is a toroidal inductor.

15. The circuit of claim 12 wherein said inductor is a dual core closed bobbin shielded inductor.

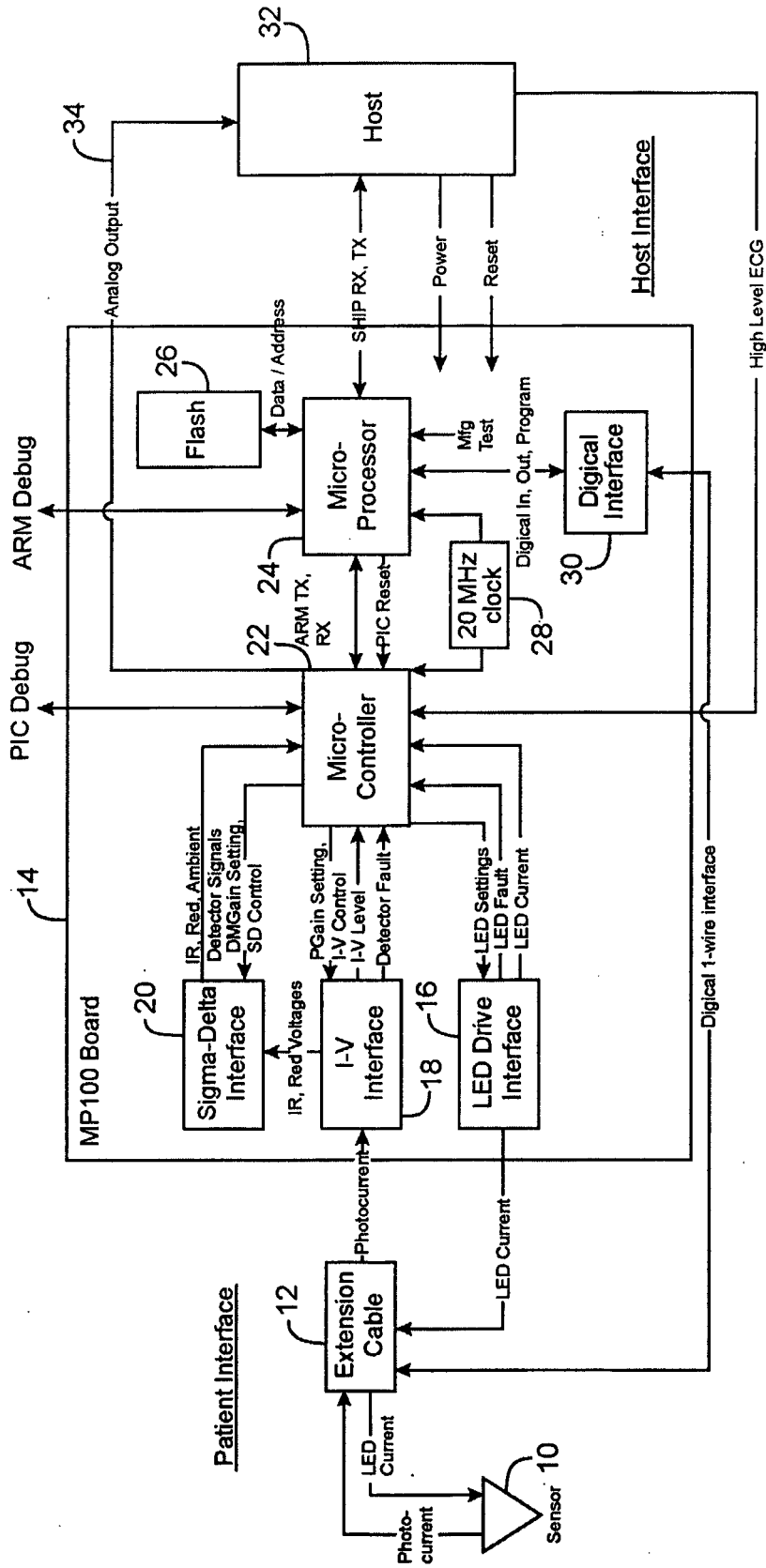

FIG. 1

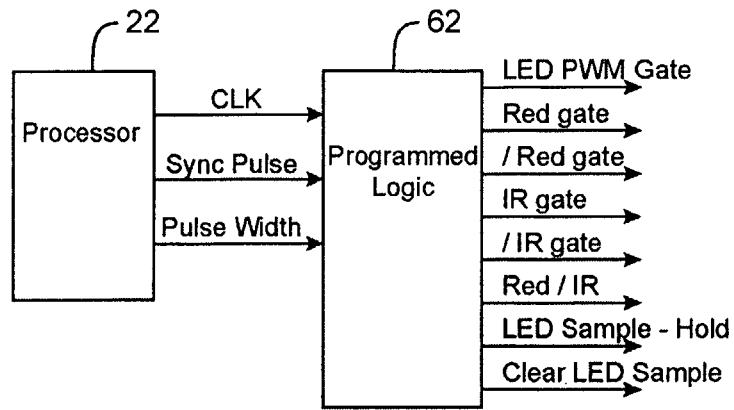

FIG. 3

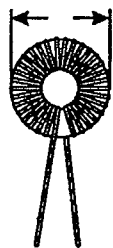

FIG. 4

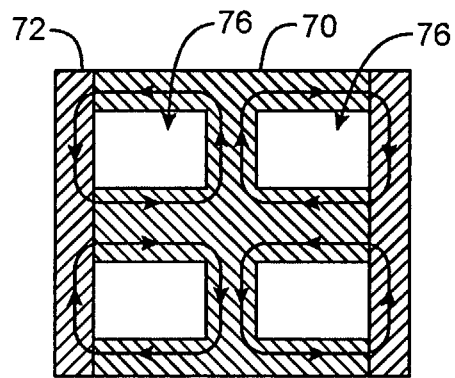

FIG. 5

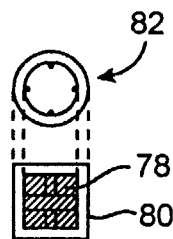

FIG. 6

INTERNATIONAL SEARCH REPORT

International Application No
PCT/US2005/006207

A. CLASSIFICATION OF SUBJECT MATTER
IPC 7 A61B5/00

According to International Patent Classification (IPC) or to both national classification and IPC

B. FIELDS SEARCHED

Minimum documentation searched (classification system followed by classification symbols)
IPC 7 A61B H05B H01F

Documentation searched other than minimum documentation to the extent that such documents are included in the fields searched

Electronic data base consulted during the international search (name of data base and, where practical, search terms used)

EP0-Internal

C. DOCUMENTS CONSIDERED TO BE RELEVANT

Category °	Citation of document, with indication, where appropriate, of the relevant passages	Relevant to claim No.
Y	US 6 198 405 B1 (ANDERSSON HAAKAN ET AL) 6 March 2001 (2001-03-06) column 3, line 53 - line 58 column 15, line 14 - column 16, line 10 figure 13	1-9,11, 12,14,15
Y	US 6 665 551 B1 (SUZUKI TETSUO) 16 December 2003 (2003-12-16) column 1, line 1 - line 67 figure 5	1-9,11, 12,14,15
A	US 5 165 162 A (CHARLES ET AL) 24 November 1992 (1992-11-24) abstract; figure 1	8,14
A	GB 2 044 550 A (GE) 15 October 1980 (1980-10-15) page 1, line 95 - line 130 figure 1	9,15

Further documents are listed in the continuation of box C.

Patent family members are listed in annex.

° Special categories of cited documents :

- "A" document defining the general state of the art which is not considered to be of particular relevance
- "E" earlier document but published on or after the international filing date
- "L" document which may throw doubts on priority claim(s) or which is cited to establish the publication date of another citation or other special reason (as specified)
- "O" document referring to an oral disclosure, use, exhibition or other means
- "P" document published prior to the international filing date but later than the priority date claimed

- "T" later document published after the international filing date or priority date and not in conflict with the application but cited to understand the principle or theory underlying the invention
- "X" document of particular relevance; the claimed invention cannot be considered novel or cannot be considered to involve an inventive step when the document is taken alone
- "Y" document of particular relevance; the claimed invention cannot be considered to involve an inventive step when the document is combined with one or more other such documents, such combination being obvious to a person skilled in the art.
- "&" document member of the same patent family

Date of the actual completion of the international search

20 May 2005

Date of mailing of the international search report

19 AUG 2005

Name and mailing address of the ISA

European Patent Office, P.B. 5818 Patentlaan 2
NL - 2280 HV Rijswijk
Tel. (+31-70) 340-2040, Tx. 31 651 epo nl,
Fax: (+31-70) 340-3016

Authorized officer

Visser, R

INTERNATIONAL SEARCH REPORT

International application No.
PCT/US2005/006207

Box II Observations where certain claims were found unsearchable (Continuation of item 2 of first sheet)

This International Search Report has not been established in respect of certain claims under Article 17(2)(a) for the following reasons:

1. Claims Nos.:
because they relate to subject matter not required to be searched by this Authority, namely:

2. Claims Nos.:
because they relate to parts of the International Application that do not comply with the prescribed requirements to such an extent that no meaningful International Search can be carried out, specifically:

3. Claims Nos.:
because they are dependent claims and are not drafted in accordance with the second and third sentences of Rule 6.4(a).

Box III Observations where unity of invention is lacking (Continuation of item 3 of first sheet)

This International Searching Authority found multiple inventions in this international application, as follows:

see additional sheet

1. As all required additional search fees were timely paid by the applicant, this International Search Report covers all searchable claims.

2. As all searchable claims could be searched without effort justifying an additional fee, this Authority did not invite payment of any additional fee.

3. As only some of the required additional search fees were timely paid by the applicant, this International Search Report covers only those claims for which fees were paid, specifically claims Nos.:

4. No required additional search fees were timely paid by the applicant. Consequently, this International Search Report is restricted to the invention first mentioned in the claims; it is covered by claims Nos.:

1-12, 14, 15

Remark on Protest

The additional search fees were accompanied by the applicant's protest.

No protest accompanied the payment of additional search fees.

FURTHER INFORMATION CONTINUED FROM PCT/ISA/ 210

This International Searching Authority found multiple (groups of) inventions in this international application, as follows:

1. claims: 1-12, 14, 15

Alternately coupling energy to drive lines

2. claim: 13

Magnetic flux cancelling inductor configuration

INTERNATIONAL SEARCH REPORT

Information on patent family members

International Application No
PCT/US2005/006207

Patent document cited in search report	Publication date	Patent family member(s)	Publication date	
US 6198405	B1	06-03-2001	SE 519550 C2	11-03-2003
			AU 730938 B2	22-03-2001
			AU 5580598 A	31-07-1998
			BR 9714247 A	18-04-2000
			DE 69713391 D1	18-07-2002
			DE 69713391 T2	06-02-2003
			EE 9900268 A	15-02-2000
			EP 0950342 A1	20-10-1999
			JP 2001508612 T	26-06-2001
			SE 9700013 A	04-07-1998
			WO 9830070 A1	09-07-1998
			TR 9901532 T2	21-09-1999

US 6665551	B1	16-12-2003	JP 2001204713 A	31-07-2001

US 5165162	A	24-11-1992	NONE	

GB 2044550	A	15-10-1980	DE 3008447 A1	18-09-1980
			FR 2451092 A1	03-10-1980
			JP 55140217 A	01-11-1980

专利名称(译)	具有单个电感器的开关模式血氧计LED驱动器		
公开(公告)号	EP1722673A1	公开(公告)日	2006-11-22
申请号	EP2005723886	申请日	2005-02-25
[标]申请(专利权)人(译)	内尔科尔普里坦贝内特公司		
申请(专利权)人(译)	NELLCOR PURITAN BENNETT INCORPORATED		
当前申请(专利权)人(译)	NELLCOR PURITAN BENNETT LLC		
[标]发明人	CHEW BRADFORD B PETERSEN ETHAN SHEA WILLIAM		
发明人	CHEW, BRADFORD, B. PETERSEN, ETHAN SHEA, WILLIAM		
IPC分类号	A61B5/00		
CPC分类号	A61B5/14551		
代理机构(译)	GRUBERT , ANDREAS		
优先权	10/787852 2004-02-25 US		
其他公开文献	EP1722673B1		
外部链接	Espacenet		

摘要(译)

一种用于血氧计的光发射器驱动电路，其利用单个电感器（L6）来驱动多个光发射器（50）。电感器连接到开关电路（40）到多个能量存储电路，例如电容器。使用相同的电感器交替充电。随后，电容器通过相同的电感器交替地对其相应的光发射器放电。而且，通过在电感器中使用磁通消除来降低LED驱动电路的磁化率。在一个实施例中，使用具有几何对称性及其磁通量的环形电感器。在另一个实施例中，使用双芯闭合线圈屏蔽电感器。