

(19) World Intellectual Property Organization
International Bureau



(43) International Publication Date
9 September 2005 (09.09.2005)

PCT

(10) International Publication Number
WO 2005/082238 A1

- (51) International Patent Classification⁷: A61B 5/00
- (21) International Application Number: PCT/US2005/006206
- (22) International Filing Date: 25 February 2005 (25.02.2005)
- (25) Filing Language: English
- (26) Publication Language: English
- (30) Priority Data: 10/788,239 25 February 2004 (25.02.2004) US

(81) Designated States (unless otherwise indicated, for every kind of national protection available): AE, AG, AL, AM, AT, AU, AZ, BA, BB, BG, BR, BW, BY, BZ, CA, CH, CN, CO, CR, CU, CZ, DE, DK, DM, DZ, EC, EE, EG, ES, FI, GB, GD, GE, GH, GM, HR, HU, ID, IL, IN, IS, JP, KE, KG, KP, KR, KZ, LC, LK, LR, LS, LT, LU, LV, MA, MD, MG, MK, MN, MW, MX, MZ, NA, NI, NO, NZ, OM, PG, PH, PL, PT, RO, RU, SC, SD, SE, SG, SK, SL, SM, SY, TJ, TM, TN, TR, TT, TZ, UA, UG, US, UZ, VC, VN, YU, ZA, ZM, ZW.

(71) Applicant (for all designated States except US): **NELL-COR PURITAN BENNETT INCORPORATED** [US/US]; 4280 Hacienda Drive, Pleasanton, CA 94588 (US).

(84) Designated States (unless otherwise indicated, for every kind of regional protection available): ARIPO (BW, GH, GM, KE, LS, MW, MZ, NA, SD, SL, SZ, TZ, UG, ZM, ZW), Eurasian (AM, AZ, BY, KG, KZ, MD, RU, TJ, TM), European (AT, BE, BG, CH, CY, CZ, DE, DK, EE, ES, FI, FR, GB, GR, HU, IE, IS, IT, LT, LU, MC, NL, PL, PT, RO, SE, SI, SK, TR), OAPI (BF, BJ, CF, CG, CI, CM, GA, GN, GQ, GW, ML, MR, NE, SN, TD, TG).

- (72) Inventors; and
- (75) Inventors/Applicants (for US only): **CHEW, Bradford, B.** [US/US]; 805 Springbrook Drive, San Ramon, CA 94583 (US). **PETERSEN, Ethan** [US/US]; 18968 Thornbury Avenue, Castro Valley, CA 94546 (US). **SHEA, William** [US/US]; 4049 Findlay Way, Livermore, CA 94550 (US).
- (74) Agents: **SLAYDEN, Bruce, W., II** et al.; Baker Botts L.L.P., 1500 San Jacinto Center, 98 San Jacinto Blvd., Austin, Texas 78701-4039 (US).

Declaration under Rule 4.17:

— as to applicant's entitlement to apply for and be granted a patent (Rule 4.17(ii)) for the following designations AE, AG, AL, AM, AT, AU, AZ, BA, BB, BG, BR, BW, BY, BZ, CA, CH, CN, CO, CR, CU, CZ, DE, DK, DM, DZ, EC, EE, EG, ES, FI, GB, GD, GE, GH, GM, HR, HU, ID, IL, IN, IS, JP, KE, KG, KP, KR, KZ, LC, LK, LR, LS, LT, LU, LV, MA, MD, MG, MK, MN, MW, MX, MZ, NA, NI, NO, NZ, OM,

[Continued on next page]

(54) Title: OXIMETER RED AND IR ZERO CALIBRATION CONTROL

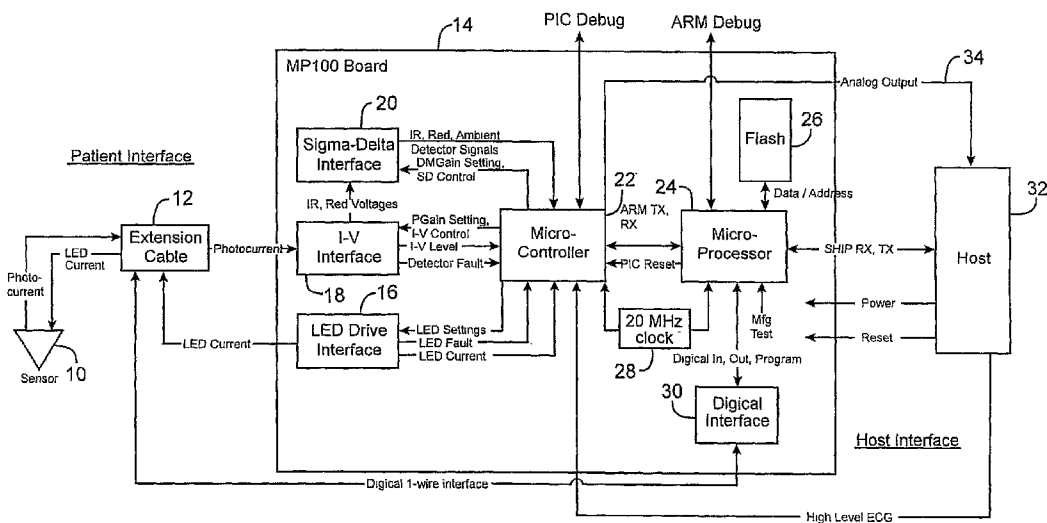

(57) Abstract: A pulse oximeter with drive lines for driving red and IR LEDs, and a drive circuit for driving those drive lines. A processor controls the drive circuit using a red zero output line and an IR zero output line directly connected between the processor and the drive circuit. This allows a control signal to directly control the turning off of either the red or IR drive transistors to prevent forward current flow through the red and IR LEDs by overriding the ongoing programmable logic state machine control of the drive transistors. The effects of crosstalk and capacitive coupling are reduced as a result.

WO 2005/082238 A1



PG, PH, PL, PT, RO, RU, SC, SD, SE, SG, SK, SL, SM, SY, TJ, TM, TN, TR, TT, TZ, UA, UG, UZ, VC, VN, YU, ZA, ZM, ZW, ARIPO patent (BW, GH, GM, KE, LS, MW, MZ, NA, SD, SL, SZ, TZ, UG, ZM, ZW), Eurasian patent (AM, AZ, BY, KG, KZ, MD, RU, TJ, TM), European patent (AT, BE, BG, CH, CY, CZ, DE, DK, EE, ES, FI, FR, GB, GR, HU, IE, IS, IT, LU, MC, NL, PL, PT, RO, SE, SI, SK, TR), OAPI patent (BF, BJ, CF, CG, CI, CM, GA, GN, GQ, GW, ML, MR, NE, SN, TD, TG)

Published:

— with international search report

For two-letter codes and other abbreviations, refer to the "Guidance Notes on Codes and Abbreviations" appearing at the beginning of each regular issue of the PCT Gazette.

OXIMETER RED AND IR ZERO CALIBRATION CONTROL

BACKGROUND OF THE INVENTION

[0001] The present invention relates to oximeters, and in particular to LED drive circuits in pulse oximeters.

[0002] Pulse oximetry is typically used to measure various blood chemistry characteristics including, but not limited to, the blood-oxygen saturation of hemoglobin in arterial blood, the volume of individual blood pulsations supplying the tissue, and the rate of blood pulsations corresponding to each heartbeat of a patient. Measurement of these characteristics has been accomplished by use of a non-invasive sensor which scatters light through a portion of the patient's tissue where blood perfuses the tissue, and photoelectrically senses the absorption of light in such tissue. The amount of light absorbed at various wavelengths is then used to calculate the amount of blood constituent being measured.

[0003] The light scattered through the tissue is selected to be of one or more wavelengths that are absorbed by the blood in an amount representative of the amount of the blood constituent present in the blood. The amount of transmitted light scattered through the tissue will vary in accordance with the changing amount of blood constituent in the tissue and the related light absorption. For measuring blood oxygen level, such sensors have typically been provided with a light source that is adapted to generate light of at least two different wavelengths, and with photodetectors sensitive to both of those wavelengths, in accordance with known techniques for measuring blood oxygen saturation.

[0004] Known non-invasive sensors include devices that are secured to a portion of the body, such as a finger, an ear or the scalp. In animals and humans, the tissue of these body portions is perfused with blood and the tissue surface is readily accessible to the sensor.

[0005] The light sources, typically light emitting diodes (LEDs), need to be driven with current to activate them. In order to reduce the effects of leakage and capacitively coupled transients, it is desirable to be able to drive one of the LEDs, without any current going through the other one. Typically, this can be done by controlling the duty cycle with the processor in the pulse oximeter. However, using the duty cycle controls to eliminate current through one of the LEDs has been discovered to still involve an amount of leakage and capacitively coupled transients that is undesirable.

BRIEF SUMMARY OF THE INVENTION

[0006] The present invention provides a pulse oximeter with drive lines for driving red and IR LEDs, and a drive circuit for driving those drive lines. A processor controls the drive circuit using a red zero output line and an IR zero output line directly connected between the processor and the drive circuit. This allows a control signal to directly control the turning off of either the red or IR drive transistors which direct forward current flow through the red and IR LEDs.

[0007] In one embodiment, the red and IR zero output lines are connected to a programmed logic circuit. The programmed logic circuit, which is controlled by the processor, provides the various timing signals for the transistors of the drive circuit. In one embodiment, the drive circuit includes an H-bridge circuit with red and IR FET drive transistors.

[0008] For a further understanding of the nature and advantages of the present invention, reference should be made to the following description taken in conjunction with the accompanying drawings.

BRIEF DESCRIPTION OF THE DRAWINGS

[0009] Fig. 1 is a block diagram of an oximeter incorporating the present invention.

[0010] Fig. 2 is a circuit diagram of a LED drive circuit according to an embodiment of the present invention.

[0011] Fig. 3 is a block diagram of one embodiment of the logic for generating the timing and control signals for the circuit of Fig. 2.

DETAILED DESCRIPTION OF THE INVENTION

Oximeter Front End

[0012] Fig. 1 illustrates an embodiment of an oximetry system incorporating the present invention. A sensor 10 includes red and infrared LEDs and a photodetector. These are connected by a cable 12 to a board 14. LED drive current is provided by an LED drive interface 16. The received photocurrent from the sensor is provided to an I-V interface 18. The IR and red voltages are then provided to a sigma-delta interface 20 incorporating the present invention. The output of sigma-delta interface 20 is provided to a microcontroller 22 which includes a 10-bit A/D converter. Controller 22 includes flash memory for a program, and EEPROM memory for data. The processor also includes a controller chip 24 connected

to a flash memory 26. Finally, a clock 28 is used and an interface 30 to a digital calibration in the sensor 10 is provided. A separate host 32 receives the processed information, as well as receiving an analog signal on a line 34 for providing an analog display.

LED Drive Circuit

[0013] Fig. 2 is a circuit diagram of the LED drive circuit according to an embodiment of the invention, which forms a portion of LED drive interface 16 of Fig. 1. A voltage regulator 36 provides a voltage separate from the voltage supply for the overall oximeter circuitry. The output is provided as a 4.5 volt signal on line 38, with the level being set by the feedback resistor divider of resistors R89 and R90. The voltage on line 38 is provided to a FET transistor Q11 to an inductor L6. The current through inductor L6 is provided by a switch 40 to one of capacitors C65 and C66, which store charge for the red and IR LEDs, respectively. A red/IR control signal on line 42 selects the switch position under control of the oximeter processor. A control signal LED PWM gate on line 44 controls the switching of transistor switch Q11.

[0014] Once the capacitors are charged up, the control signal on line 44 turns off switch Q11 and current is provided from either capacitor C65 or C66, through switch 40 and inductor L6 to either the red anode line 46 or the IR anode line 48 by way of transistors Q5 and Q6, respectively. A signal "red gate" turns on transistor Q5, while its inverse, "/red gate" turns off transistor Q7. This provides current through the red anode line 46 to the back to back LEDs 50, with the current returning through the IR anode to transistor Q8 and through resistor R10 to ground. Transistor Q8 is turned on by the signal "/IR gate" while the inverse of this signal, "IR gate" turns off transistor Q6. The signals are reversed when the IR anode is to be driven, with the "IR gate" and "red gate" signals, and their inverses, changing state, so that current is provided through transistor Q6 to IR anode 48 and returns through red anode 46 and through transistor Q7 to resistor R10 and ground. The "LED current sense" signal is read for calibration purposes not relevant to the present invention.

[0015] When the current from the capacitor C65 or C66 is provided through inductor L6 to the LEDs, and that current is switched off at the desired time, transistor Q11 is turned on so that the remaining current during the transition can be dumped into capacitor C64. This addresses the fact that the FET transistor switching is not instantaneous. Subsequently, C64 will dump its current through Q11 and inductor L6 into the capacitors when they are recharged.

[0016] Resistor R38 and capacitor C67 are connected in parallel to inductor L6 to protect against signal spikes, and provide a smooth transition. Connected to inductor L6 is a sampling circuit with a switch 52 controlled by an LED sample hold signal on line 54 to sample the signals and provide them through an amplifier 56 to a "LED current" signal on line 58 which is read by the processor. An integrating capacitor C68 is provided in parallel to amplifier 56. A switch 60 responds to a "clear LED sample" signal to operate the switch to short out the capacitor between samples.

[0017] The sample and hold circuit measures the voltage at node T18, between capacitor C69 and inductor L6, to determine the current. Capacitor C69 is 1/1000 of the value of capacitors C65 and C66. Thus, a proportional current is provided through C69, which is injected through switch 52 to integrating capacitor C68 to provide a voltage which can be measured at the output of amplifier 56 on line 58. The voltage measured by the processor on line 58 is used as a feedback, with the processor varying the width of the pulse delivered to transistor Q11 to selectively vary the amount of energy that's delivered to the capacitors 65 and 66, and then is eventually discharged to the LEDs 50. A PI (Proportional Integral) loop inside the processor then controls the PWM signal at Q11. This allows precise control of the LED intensity, allowing it to be maximized, if desired, without exceeding the desired limits (to avoid burning the patient, etc.).

[0018] The lower left of the diagram shows a "4.5 v LED disable" signal which is used by the microprocessor to turn off the voltage regulator 36 in certain instances. For example, diagnostics looking for shorts in a new sensor plugged in will turn off the voltage regulator if there is a problem with the LED line.

Zero Calibration Control

[0019] Fig. 3 illustrates processor 22, from Fig. 1, connected to programmed logic 62, which is in the LED drive interface 16 in Fig. 1. Programmed logic 62 provides the different control signals used by the circuit of Fig. 2 in response to basic timing signals from the processor of a clock, a sync pulse, and a pulse width signal.

[0020] As can be seen, processor 22 also provides a red zero signal on a line 64 and an IR zero signal on a line 66. These two signals go to programmed logic circuit 62. Programmed logic 62, in response to assertion of the red zero signal, will provide appropriate control signals on the red gate, /red gate, IR gate and /IR gate control outputs to control the drive transistors in Figure 2. In particular, assertion of the red zero signal will cause the red gate

signal to turn off transistor Q5 and transistor Q8. The programmable logic for switching between the LEDs still functions, but is overridden by this zero signal. Thus, the red gate is held at its value regardless of efforts by the programmable logic state machine to cycle it on and off. Similarly, assertion of the IR zero signal on line 66 will cause program logic circuit 62 to turn off transistor Q6 with the IR gate signal, and turn off transistor Q7 with the /red gate signal.

[0021] These control signals thus assure that current only flows through the red LED or the IR LED, without any leakage due to switching between them while the appropriate red zero or IR zero signal is asserted. This significantly reduces any switching leakage due to use of the duty cycle controls and any capacitively coupled switching transients.

[0022] As will be understood by those of skill in the art, the present invention can be embodied in other specific forms without departing from the essential characteristics thereof. For example, a different drive transistor structure could be used, such as for LEDs that are not configured back-to-back, but rather have separate connections which are separately driven. Accordingly, the foregoing description is intended to be illustrative, but not limiting, of the scope of the invention which is set forth in the following claims.

WHAT IS CLAIMED IS:

1. A pulse oximeter comprising:
 - a red drive line for a red light emitting diode (LED);
 - an infrared (IR) drive line for an IR LED;
 - a drive circuit coupled to said red and IR drive lines;
 - a processor for controlling said drive circuit, said processor having a red zero output line and an IR zero output line coupled to said drive circuit, wherein a control signal on said zero output lines turns off a red or IR drive transistor providing forward current flow through said red and IR LEDs, respectively.
2. The pulse oximeter of claim 1 further comprising:
 - a logic circuit, having inputs connected to said red and IR zero drive lines, and outputs providing control signals to said drive circuit.
3. The pulse oximeter of claim 2 wherein said logic circuit is programmed.
4. The pulse oximeter of claim 2 wherein said red and IR drive transistors comprise red and IR source transistors and red and IR sink transistors in an H-bridge arrangement coupled to a return line from said red and IR LEDs.
5. The pulse oximeter of claim 3 wherein said LEDs are arranged back-to-back, such that said drive line for said red LED is said return line for said IR LED, and said drive line for said IR LED is said return line for said red LED.
6. A pulse oximeter comprising:
 - a red drive line for a red light emitting diode (LED);
 - an infrared (IR) drive line for an IR LED;
 - a drive circuit coupled to said red and IR drive lines;
 - a logic circuit, having inputs connected to red and IR zero drive lines, and outputs providing control signals to said drive circuit; and
 - a processor for controlling said programmed logic circuit, said processor being coupled to and driving said red zero output line and said IR zero output line, wherein a control signal on said zero output lines causes said programmed logic circuit to turn off a red

or IR drive transistor providing forward current flow through said red and IR LEDs, respectively.

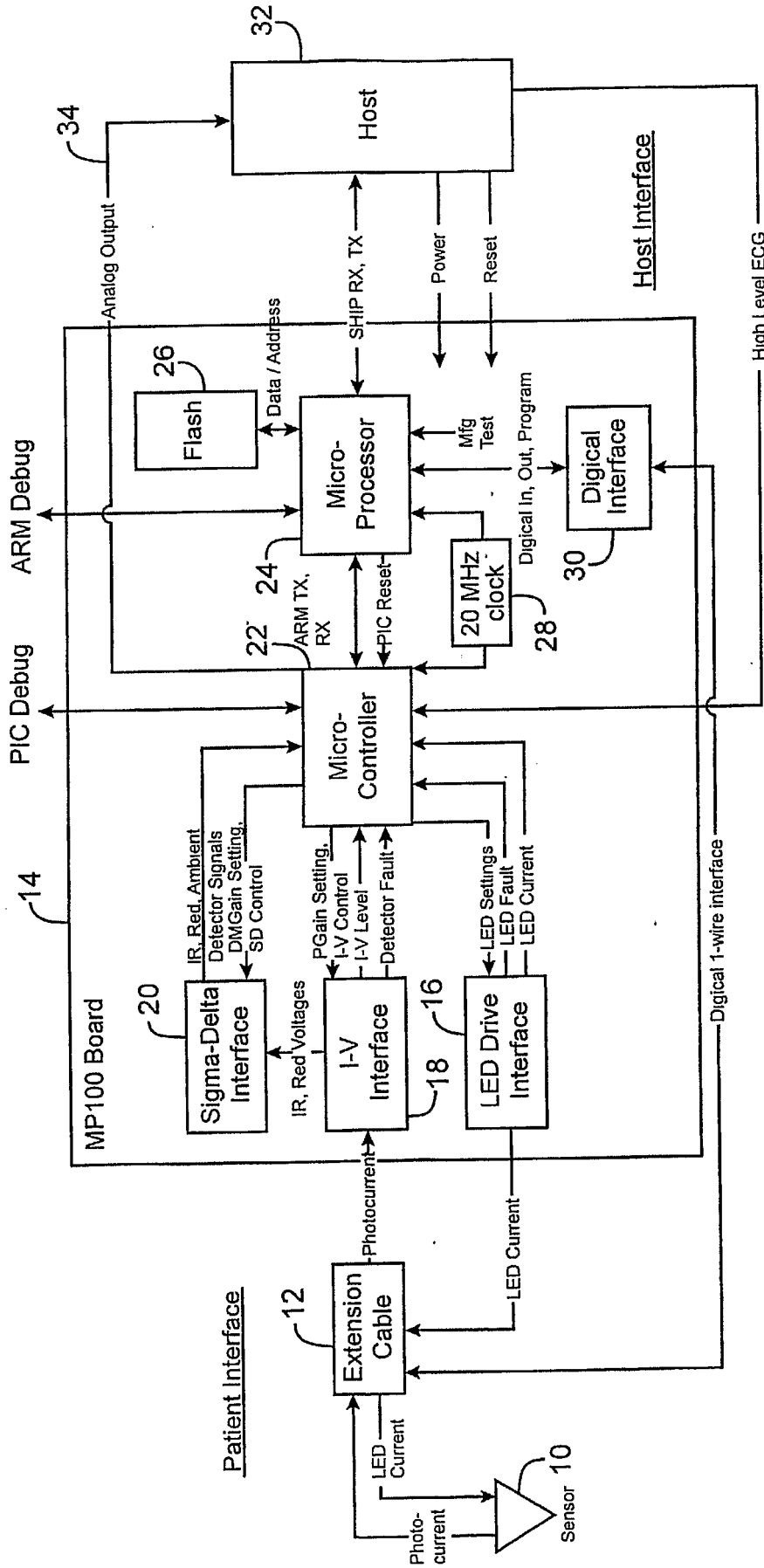

FIG. 1

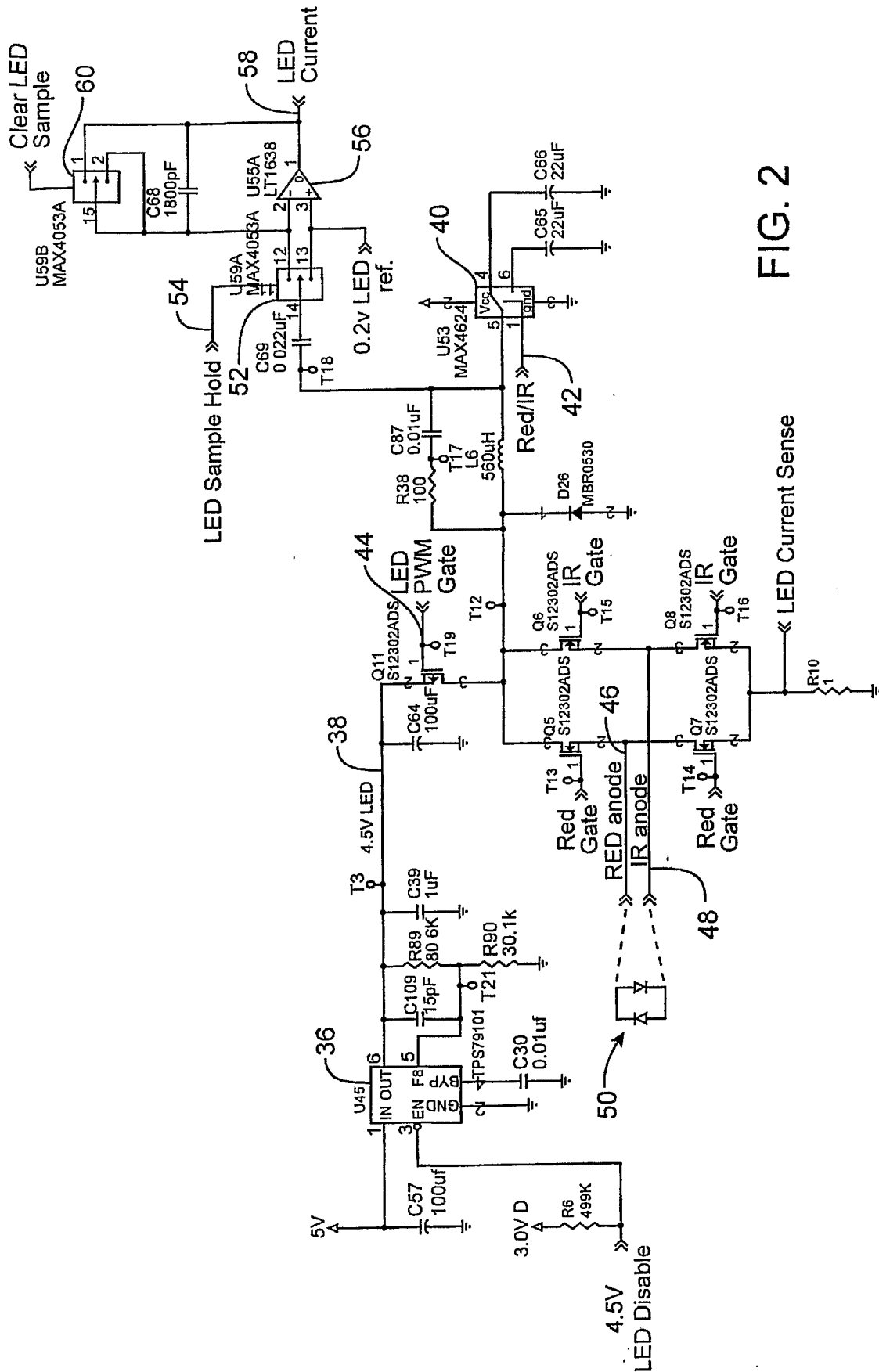

FIG. 2

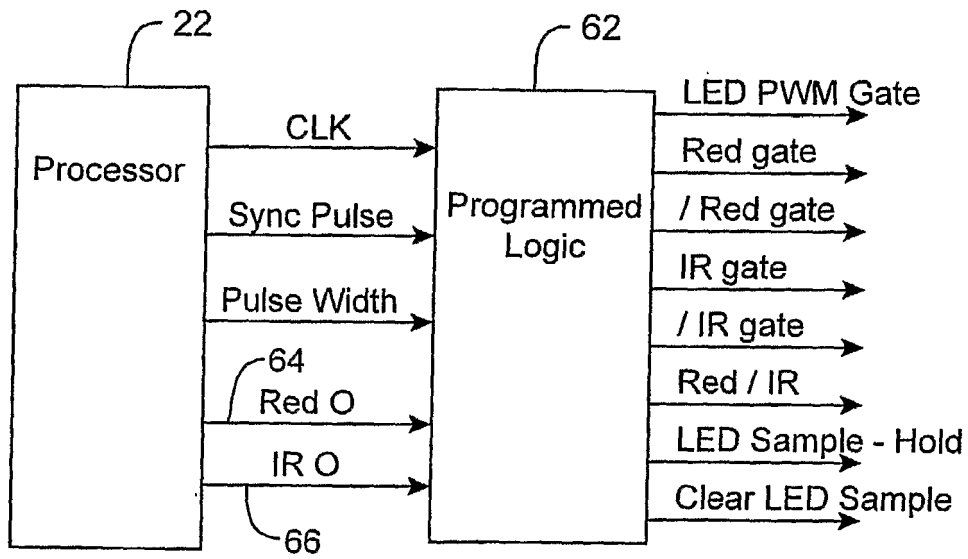

FIG. 3

INTERNATIONAL SEARCH REPORT

Internat. Application No
PCT/US2005/006206A. CLASSIFICATION OF SUBJECT MATTER
IPC 7 A61B5/00

According to International Patent Classification (IPC) or to both national classification and IPC

B. FIELDS SEARCHED

Minimum documentation searched (classification system followed by classification symbols)
IPC 7 A61B G01N H05B

Documentation searched other than minimum documentation to the extent that such documents are included in the fields searched

Electronic data base consulted during the international search (name of data base and, where practical, search terms used)
EPO-Internal

C. DOCUMENTS CONSIDERED TO BE RELEVANT

Category °	Citation of document, with indication, where appropriate, of the relevant passages	Relevant to claim No.
P,X	WO 2004/047631 A (MASIMO LABORATORIES, INC) 10 June 2004 (2004-06-10) page 6, line 6 - page 7, line 26 page 9, line 3 - line 13 page 11, line 10 - page 12, line 27 figures 2A,3,5,6B,7,9-11 -----	1-3,6
Y	US 2001/002206 A1 (DIAB MOHAMED K ET AL) 31 May 2001 (2001-05-31) paragraphs '0006!, '0042! - '0045!, '0063!, '0074! - '0079!, '0100! - '0104!, '0108!, '0115!, '0117! figures 1,2,8-10 -----	1-6
Y	US 5 818 985 A (MERCHANT ET AL) 6 October 1998 (1998-10-06) figure 6 -----	1-6
	-/--	

 Further documents are listed in the continuation of box C. Patent family members are listed in annex.

° Special categories of cited documents :

- *A* document defining the general state of the art which is not considered to be of particular relevance
- *E* earlier document but published on or after the international filing date
- *L* document which may throw doubts on priority claim(s) or which is cited to establish the publication date of another citation or other special reason (as specified)
- *O* document referring to an oral disclosure, use, exhibition or other means
- *P* document published prior to the international filing date but later than the priority date claimed

- *T* later document published after the international filing date or priority date and not in conflict with the application but cited to understand the principle or theory underlying the invention
- *X* document of particular relevance; the claimed invention cannot be considered novel or cannot be considered to involve an inventive step when the document is taken alone
- *Y* document of particular relevance; the claimed invention cannot be considered to involve an inventive step when the document is combined with one or more other such documents, such combination being obvious to a person skilled in the art.
- * & * document member of the same patent family

Date of the actual completion of the international search

17 May 2005

Date of mailing of the international search report

08/06/2005

Name and mailing address of the ISA

European Patent Office, P.B. 5818 Patentlaan 2
NL - 2280 HV Rijswijk
Tel. (+31-70) 340-2040, Tx. 31 651 epo nl,
Fax: (+31-70) 340-3016

Authorized officer

Visser, R

INTERNATIONAL SEARCH REPORT

Internat Application No

PCT/US2005/006206

C.(Continuation) DOCUMENTS CONSIDERED TO BE RELEVANT

Category °	Citation of document, with indication, where appropriate, of the relevant passages	Relevant to claim No.
A	US 2004/015093 A1 (KNAPP KEITH N ET AL) 22 January 2004 (2004-01-22) paragraph '0059!	1,2
X	US 2003/069486 A1 (SUEPPEL BRIAN E ET AL) 10 April 2003 (2003-04-10)	1
A	paragraphs '0043!, '0046!, '0057!, '0058! figures 3,4	4,5
X	US 6 343 223 B1 (CHIN RODNEY ET AL) 29 January 2002 (2002-01-29)	1
A	column 4, line 26 - line 44 figure 1	3
A	US 2002/098120 A1 (BLAZEWICZ PERRY R ET AL) 25 July 2002 (2002-07-25) paragraphs '0119!, '0120!, '0136! figures 15,17	2,3
A	US 6 665 551 B1 (SUZUKI TETSUO) 16 December 2003 (2003-12-16) figure 4	4,5
A	US 5 008 595 A (KAZAR ET AL) 16 April 1991 (1991-04-16) column 5, line 25 figure 15	2-5

INTERNATIONAL SEARCH REPORT

Information on patent family members

International Application No

PCT/US2005/006206

Patent document cited in search report	Publication date	Patent family member(s)	Publication date	
WO 2004047631	A	10-06-2004	WO 2004047631 A2 US 2004107065 A1	10-06-2004 03-06-2004
US 2001002206	A1	31-05-2001	US 6229856 B1 US 2004152965 A1 EP 1067861 A1 JP 2002511291 T WO 9952420 A1 AU 6895498 A US 5919134 A WO 9846125 A1	08-05-2001 05-08-2004 17-01-2001 16-04-2002 21-10-1999 11-11-1998 06-07-1999 22-10-1998
US 5818985	A	06-10-1998	AU 1347297 A CA 2239080 A1 DE 69627544 D1 DE 69627544 T2 EP 0957751 A1 HK 1026128 A1 JP 2000501974 T US 6023541 A WO 9722294 A1	14-07-1997 26-06-1997 22-05-2003 08-04-2004 24-11-1999 10-10-2003 22-02-2000 08-02-2000 26-06-1997
US 2004015093	A1	22-01-2004	US 6436053 B1 US 6106481 A CA 2381817 A1 EP 1215997 A1 JP 2003509099 T WO 0119245 A1 CA 2304541 A1 EP 1019147 A1 JP 2001518330 T WO 9916506 A1	20-08-2002 22-08-2000 22-03-2001 26-06-2002 11-03-2003 22-03-2001 08-04-1999 19-07-2000 16-10-2001 08-04-1999
US 2003069486	A1	10-04-2003	NONE	
US 6343223	B1	29-01-2002	US 6466808 B1 US 6115621 A	15-10-2002 05-09-2000
US 2002098120	A1	25-07-2002	EP 1354191 A2 JP 2004522955 T WO 02059585 A2 US 2003190262 A1	22-10-2003 29-07-2004 01-08-2002 09-10-2003
US 6665551	B1	16-12-2003	JP 2001204713 A	31-07-2001
US 5008595	A	16-04-1991	US 4870325 A	26-09-1989

专利名称(译)	血氧计红色和红外零校准控制		
公开(公告)号	EP1722672A1	公开(公告)日	2006-11-22
申请号	EP2005723885	申请日	2005-02-25
[标]申请(专利权)人(译)	内尔科尔普里坦贝内特公司		
申请(专利权)人(译)	NELLCOR PURITAN BENNETT INCORPORATED		
当前申请(专利权)人(译)	NELLCOR PURITAN BENNETT INCORPORATED		
[标]发明人	CHEW BRADFORD B PETERSEN ETHAN SHEA WILLIAM		
发明人	CHEW, BRADFORD, B. PETERSEN, ETHAN SHEA, WILLIAM		
IPC分类号	A61B5/00		
CPC分类号	A61B5/1495 A61B5/14551		
代理机构(译)	GRUBERT , ANDREAS		
优先权	10/788239 2004-02-25 US		
外部链接	Espacenet		

摘要(译)

带有用于驱动红色和红外LED的驱动线的脉冲血氧计，以及用于驱动这些驱动线的驱动电路。处理器使用红色零输出线和直接连接在处理器和驱动电路之间的IR零输出线来控制驱动电路。这允许控制信号直接控制红色或IR驱动晶体管的关断，以通过超越驱动晶体管的正在进行的可编程逻辑状态机控制来防止正向电流流过红色和IR LED。结果，减少了串扰和电容耦合的影响。