



(12) **EUROPEAN PATENT APPLICATION**

(43) Date of publication:  
**20.04.2011 Bulletin 2011/16**

(51) Int Cl.:  
**A61B 5/00 (2006.01)**

(21) Application number: **10186856.0**

(22) Date of filing: **07.10.2010**

(84) Designated Contracting States:  
**AL AT BE BG CH CY CZ DE DK EE ES FI FR GB GR HR HU IE IS IT LI LT LU LV MC MK MT NL NO PL PT RO RS SE SI SK SM TR**  
Designated Extension States:  
**BA ME**

- **Echigo, Masahiro**  
Shinjuku-ku Tokyo (JP)
- **Oyagi, Rie**  
Shinjuku-ku Tokyo (JP)
- **Tezuka, Shinji**  
Shinjuku-ku Tokyo (JP)
- **Enomoto, Yoshinori**  
Shinjuku-ku Tokyo (JP)

(30) Priority: **07.10.2009 JP 2009233153**

(71) Applicant: **Nihon Kohden Corporation**  
Shinjuku-ku  
Tokyo (JP)

(74) Representative: **Grünecker, Kinkeldey, Stockmair & Schwanhäusser**  
Anwaltssozietät  
Leopoldstrasse 4  
80802 München (DE)

(72) Inventors:  
• **Tanishima, Masami**  
Shinjuku-ku Tokyo (JP)

(54) **Biological information monitoring apparatus and alarm control method**

(57) A biological information monitoring apparatus operable to measure biological information of a patient by detecting a biological signal of the patient, and operable to output an alarm, includes an alarm controller which changes the alarm. The alarm includes a first alarm

of a first priority and a second alarm of a second priority. When a first condition is satisfied, the first alarm is output. When a second condition is satisfied after the first alarm is output, the alarm controller changes from the first alarm to the second alarm to be output.

**FIG. 1**

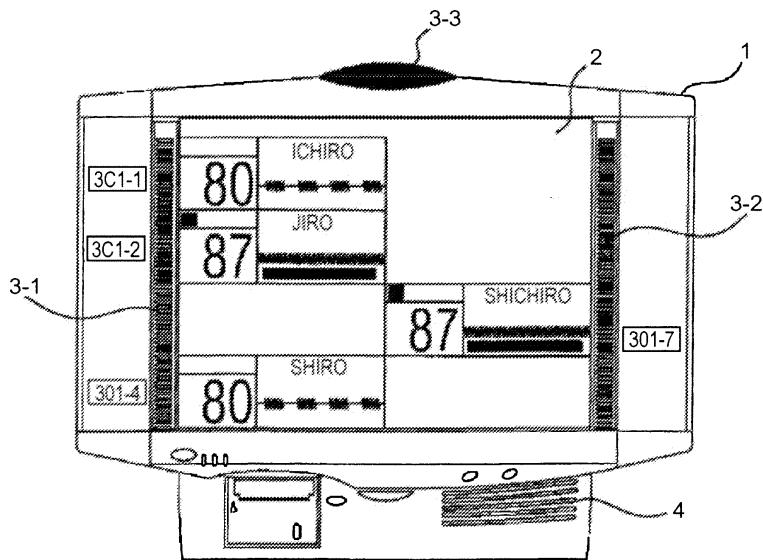

**Description****BACKGROUND OF THE INVENTION**

- 5 **[0001]** The present invention relates to a biological information monitoring apparatus which displays biological information that is obtained by processing a detection signal detected from a living body, on a displaying unit, which generates an alarm sound through a speaker, or which lights an alarm lamp in an alarm indicator configured by LEDs and the like, and particularly to a biological information monitoring apparatus which can output a visual alarm and auditory alarm in which the alarm priority of a vital alarm that is to be output in abnormality of the detection signal, or that of a technical alarm that is to be output in abnormality of the biological information monitoring apparatus, a sensor, or the measurement environment is changed depending on the situation. The invention relates also to an alarm control method.
- 10 **[0002]** As an example of a patient monitoring apparatus, the following configuration is disclosed in JP-A-2009-101214.
- [0003]** A typical pulse oximeter measures two biological parameters (the present oxygen saturation (hereinafter, often abbreviated as sat) of blood hemoglobin, and the pulse rate (hereinafter, often referred to as rate)). For alarm purpose, normal ranges which are preferably maintained in the patient are determined, and low and high thresholds are set for both the sat and the rate. In the case of a neonatal infant, for example, the sat is preferably maintained between 80 and 95 percent, and the rate is preferably maintained in the range of 90 to 190 beats/minute.
- 15 **[0004]** From the two measured parameters, four alarm types (low sat, high sat, low rate, and high rate) are produced. In a typical pulse oximeter, when one of the sat and the rate goes outside the normal range, an alarm is immediately output, and, when both the sat and the rate return within the normal range, the alarm is immediately ended. Typically, an alarm is announced by an auditory sound and/or visual indicator.
- 20 **[0005]** Each occurrence in which a measured parameter goes outside the normal range is referred to as an event. In a typical pulse oximeter, namely, each event corresponds to an alarm, and the alarm time duration coincides with the event time duration.
- 25 **[0006]** Usually, many alarms generated by a typical pulse oximeter are not considered so as to correspond to events which are clinically effective.
- [0007]** The definition of clinical effectiveness varies depending on the patient and the environment. Usually, it is related to the severity and time duration of the event of interest. For example, a very shallow desaturation is considered effective only when sustained for a relatively long time duration.
- 30 **[0008]** Similarly, a desaturation of a very short duration is considered effective only when it falls very deep below the low sat threshold. Moreover, a parameter measurement error due to noise or signal artifact produces a false event. Any alarm which corresponds to a clinically effective event is considered a nuisance alarm.
- [0009]** Studies which attempt to reduce the number of saturation alarms have been announced. These studies are directed to lowering of the alarm threshold or waiting of a certain fixed time duration after the threshold is passed.
- 35 **[0010]** Lowering of the alarm threshold is problematic because the saturation of the patient indefinitely remains below the original threshold (which is higher than the new threshold), and an alarm is not produced.
- [0011]** Delaying of the production of an alarm by a fixed time period is also problematic because of a potentially serious situation in which the saturation of the patient abruptly falls to or remains at a very low level at which prompt medical treatment is required.
- 40 **[0012]** Therefore, the example provides a method and apparatus for controlling an alarm in a medical diagnostic apparatus in which an alarm is produced when a measured value of a biological parameter passes a threshold.
- [0013]** In the method, both the time amount for which the measured value passes the threshold, and the amount by which the measured value passes the threshold are determined (or quantized). An alarm is inhibited based on a combination of the time amount and the amount by which the threshold is passed. Preferably, the combination is an integral or some integral functions.
- 45 **[0014]** In a preferred embodiment, for a saturation alarm of a pulse oximeter, the integral of the amount by which the oxygen saturation exceeds an upper threshold or falls below a lower threshold is calculated. When the integral exceeds a predetermined value, the saturation alarm is produced.
- [0015]** For a rate alarm of a pulse oximeter, similarly, the preferred embodiment calculates the integral of the amount by which the pulse rate exceeds upper and lower thresholds. When the integral exceeds a predetermined value, the rate alarm is produced.
- 50 **[0016]** As an alarm standard for a biological information apparatus (ME apparatus), ICE 60601-1-8 is set. A summary of the standard will be described.
- [0017]** Table 1 shows alarm condition priorities in the standard of ICE 60601-1-8.
- 55 **[0018]** It is assumed that alarm conditions are assigned to one or more of a high priority, a medium priority, and a low priority. The priority is determined based on the risk management process (ISO 14971) shown in Table 1. The alarm condition priorities must be shown in an operation manual, and the priorities may be identified in a group.
- [0019]** Table 2 shows visual alarm signals in the standard of ICE 60601-1-8.

## EP 2 311 369 A1

**[0020]** In the case where an alarm indicator is necessary for the operator to identify an apparatus or part of the apparatus which requires a response or awareness by the operator, characteristics such as shown in Table 2 are provided.

**[0021]** Tables 3 (a) and 3 (b) show alarm sounds (auditory alarms) in the standard of ICE 60601-1-8.

**[0022]** Table 4 shows melody alarms in auditory alarms in the standard of ICE 60601-1-8.

**[0023]** An alarm system which emits an alarm sound must have at least one of the following sets (1) and (2):

(1) the priority is patternized, and adapted to Tables 3(a) and 3(b); and

(2) the alarm is generated by a different technique (such as an audio alarm signal), and the adequateness is confirmed.

**[0024]** In Table 4, when the absolute frequency of [c] is between 150 to 500Hz, sound can be produced by a different key. For auditory alarm signals of all alarm systems, "normal" burst can be used. In Table 4, c, d, e, f, g, a, b, and C are musical relative pitches, and C is higher than c by one octave. An alarm signal of the high priority is generated by the five indicated pulses, and repeated once so that a total of ten pulses are obtained.

Table 1 Alarm condition priority

Potential result when fail to respond to cause of alarm state	Generation of potential injury		
	Immediate	Rapid	Late
Death or irreversible injury	High priority (H)	High priority (H)	Medium priority (M)
Reversible injury	High priority (H)	Medium priority (M)	Low priority (L)
Minor injury or unpleasant feeling	Medium priority (M)	Low priority (L)	Low priority (L) or non-alarming signal

Table 2 Characteristics of light of alarm indicator

Class of alarm	Color of indicator light	Blink frequency	Operation period
High priority (H)	Red	1.4 to 2.8Hz	20 to 60% are in lit state
Medium priority (M)	Yellow	0.4 to 0.8Hz	20 to 60% are in lit state
Low priority (L)	Cyan or yellow	Constant (lit state)	100% are in lit state

Table 3(a) Characteristics of pulse sound of auditory alarm signal

Characteristics	Value
Frequency of pulse sound (f0)	150 to 1,000Hz
High-frequency component in 300 to 4,000Hz	Minimum 4
Continuous time period of effective pulse sound (td) High priority Medium and low priorities	75 to 200ms 125 to 250ms
Rising time (tr)	10 to 20% of td
Falling time (tf)	tf ≤ ts-tr

Table 3(b) Burst characteristics of auditory alarm signal

Characteristics	Alarm signal of high priority	Alarm signal of medium priority	Alarm signal of low priority
Pulse number of burst	10	3	1 or 2

(continued)

5	Spacing between pulses (ts) (see Fig. 2)			
	Between 1st pulse and 2nd pulse	x	y	y
	Between 2nd pulse and 3rd pulse	x	y	N/A
10	Between 3rd pulse and 4th pulse	2x + ts	N/A	N/A
	Between 4th pulse and 5th pulse	x	N/A	N/A
15	Between 5th pulse and 6th pulse	0.35 to 1.30s	N/A	N/A
	Between 6th pulse and 7th pulse	x	N/A	N/A
	Between 7th pulse and 8th pulse	x	N/A	N/A
20	Between 8th pulse and 9th pulse	2x + ts	N/A	N/A
	Between 9th pulse and 10th pulse	x	N/A	N/A
25	Time between bursts	2.5 to 15.0s	2.5 to 30.0s	> 15s or not repeated
	Amplitude difference between two arbitrary pulses	Maximum 10 dB	Maximum 10 dB	Maximum 10 dB

30

Table 4 Melody alarm

	Cause	Medium priority	High priority
35	General	ccc	ccc-cc
	Heart	ceg	ceg-gC
	Artificial perfusion	cf#c	cf#c-cf#
	Ventilation	caf	caf-af
40	Oxygen	Cba	Cba-gf
	Temperature/energy supply	cde	cde-fg
	Supply of medicine or liquid	Cdg	Cdg-Cd
45	Failure of apparatus or supplied product	Ccc	Ccc-Cc

[0025] As described above, the high priority, medium priority, and low priority which are alarm condition priorities in the alarm standard for a biological information apparatus (ME apparatus) are defined in detail based on the risk management process (ISO 14971) shown in Table 1, and visual and auditory alarms which are output forms of the priorities are determined in accordance with the alarm priorities.

[0026] An example of a biological information monitoring apparatus which announces an alarm by means of an auditory sound and/or visual indicator will be described with reference to Fig. 1.

[0027] Fig. 1 is an external view of a biological information monitoring apparatus of the station type which is placed in a nurse's station or the like, and in which biological signals of a plurality of patients can be simultaneously monitored.

[0028] In Fig. 1, 1 denotes the biological information monitor of the station type, and 2 denotes a display screen on which numerals and waveforms that are obtained as a result of processing biological signals of a plurality (in the illustrated apparatus, eight) of patients are simultaneously displayed (in the illustrated state, only four patients are monitored).

**[0029]** The reference numerals 3-1, 3-2, and 3-3 denote display output portions for a visual alarm. The display output portions 3-1, 3-2 are individual display portions which can perform displays respectively corresponding to individual patients, and the display output portion 3-3 is a common display portion which is common to all patients. Each of the display portions is configured by, for example, LEDs, and selectively displays red, yellow, cyan light, or like alarm light in accordance with the alarm priority. In the display screen 2, furthermore, a visual alarm may be displayed in the display regions respectively corresponding to individual patients.

**[0030]** The reference numeral 4 is a speaker which outputs an auditory alarm. The speaker can output an alarm corresponding to the alarm priority by means of different frequencies, duration times, and the like.

**[0031]** In the above-described pulse oximeter, for a saturation alarm, the integral of the amount by which the oxygen saturation exceeds the upper threshold or falls below the lower threshold is calculated. When the integral exceeds the predetermined value, the saturation alarm is produced.

**[0032]** Until the saturation alarm is produced, therefore, the exceeding (falling) amount is integrated. Therefore, an influence due to noise or signal artifact is eliminated. When the saturation alarm is once produced, however, the saturation alarm is not cancelled unless the oxygen saturation returns to the upper threshold or lower, or to the lower threshold or higher.

**[0033]** In such a state where, after the saturation alarm is once produced, the oxygen saturation remains stagnant in the vicinity of the upper or lower threshold, the saturation alarm is not cancelled, and the alarm announcement in the constant audio and/or visual form is continued, so that there arises a possibility that the observer becomes accustomed to the alarm and overlooks a serious abnormality.

**[0034]** In the integration, in the case where, because of an unexpected phenomenon or the like, the oxygen saturation largely falls below the low sat threshold in a very short time and the saturation alarm is once produced, even when the phenomenon is improved and the oxygen saturation returns to the vicinity of the threshold, the priority is maintained.

**[0035]** In this case, although an alarm which has a low priority is originally generated, an alarm in an emergency is output, thereby causing a possibility that such an alarm interferes with the work of a medical person.

**[0036]** In the alarm standard for a biological information apparatus (ME apparatus), as described above, the high priority, the medium priority, and the low priority are visual and auditory alarms which are defined in detail based on the risk management process (ISO 14971) shown in Table 1. Consequently, there is a problem in that, in the case where a visual or auditory alarm (particularly, the low priority or the medium priority) is continued, overlooking due to accustomedness easily occurs.

**[0037]** Specifically, in a state where the oxygen saturation stagnates in the vicinity of the upper or lower threshold (the medium priority), the same priority is maintained, and hence the alarm announcement in the constant audio and/or visual form is continued as indicated above-described Tables 1 to 4. Consequently, there is a possibility that a serious abnormality is overlooked because of accustomed recognition of the observer that the priority remains unchanged.

**[0038]** A generation of a technical alarm means that a failure of a biological signal measuring apparatus itself, a state where checking of a probe or detection of a pulse wave is disabled, or the like occurs. However, this is not directly related to a phenomenon in which an abnormality is caused in the biological signal of the patient. Even when a technical alarm is generated by an operation of a body motion of the patient such as separation of an electrode or a probe, it is often that restoration is immediately performed. Therefore, there is a possibility that the alarm is overlooked with a sense of expectance of recovery.

## SUMMARY

**[0039]** It is therefore an object of the invention to provide a biological information monitoring apparatus having a function of changing an alarm priority in which, in the case where, after a vital alarm that is output in abnormality of a biological signal, or a technical alarm that is output in abnormality of the biological information monitoring apparatus, a sensor, or the measurement environment is produced, the alarm is continued at the same priority, the priority of the alarm can be changed (for example, from the medium priority to the high priority) when the alarm state satisfies predetermined conditions.

**[0040]** Examples of the abnormality of the measurement environment are a state where, when a transmitter wirelessly transmits a measured biological signal, the biological information monitoring apparatus which is scheduled to receive the signal cannot receive the biological signal because of an interruption of the radio wave or a failure of reception, and a phenomenon in which the contact impedance of an electrode is increased and noises enter the signal.

**[0041]** In order to achieve the object, according to the invention, there is provided a biological information monitoring apparatus operable to measure biological information of a patient by detecting a biological signal of the patient, and operable to output an alarm, the biological information monitoring apparatus comprising: an alarm controller which changes the alarm, wherein the alarm includes a first alarm of a first priority and a second alarm of a second priority, wherein when a first condition is satisfied, the first alarm is output, and when a second condition is satisfied after the first alarm is output, the alarm controller changes from the first alarm to the second alarm to be output.

[0042] The alarm including the first alarm and the second alarm may be a technical alarm which is output when the biological information monitoring apparatus, a sensor for measuring the biological information, or measurement environment is abnormal. The second condition may be a condition that an abnormal state in which the biological information monitoring apparatus, the sensor, or the measurement environment is abnormal is continued for a time period.

[0043] The alarm including the first alarm and the second alarm may be a vital alarm which is output when the detected biological signal is abnormal. The second condition may be at least one of a condition that an abnormal state in which the detected biological signal is abnormal is continued for a time period and a condition that the detected biological signal passes a threshold indicating a dangerous state.

[0044] The biological information monitoring apparatus may further include: an inputting unit. After the alarm controller changes from the first alarm to the second alarm, a user may operate the inputting unit to change from the second alarm to the first alarm to be output.

[0045] The alarm including the first alarm and the second alarm may be a vital alarm which is output when the detected biological signal is abnormal. In a case where, after the alarm controller changes from the first alarm to the second alarm, the detected biological signal passes a threshold to an area indicating a dangerous state, and the detected biological signal returns from the area and passes the threshold, the alarm controller may change from the second alarm to the first alarm to be output.

[0046] The first condition may be a condition that the detected biological signal passes a threshold, and the threshold of the second condition may be set with being interlocked with setting of the threshold of the first condition.

[0047] Each of the time period and the threshold may be set from a plurality of candidate values.

[0048] The alarm including the first alarm and the second alarm may include at least one of a visual alarm and an auditory alarm. In the visual alarm, a blinking rate in the second alarm may be set higher than a blinking rate in the first alarm, and, in the auditory alarm, a volume in the second alarm may be set higher than a volume in the first alarm.

[0049] The alarm including the first alarm and the second alarm may include at least one of a visual alarm and an auditory alarm. In the visual alarm, a blinking rate in the second alarm may be set lower than a blinking rate in the first alarm, and, in the auditory alarm, a volume in the second alarm may be set lower than a volume in the first alarm.

[0050] The alarm including the first alarm and the second alarm may include at least one of a visual alarm and an auditory alarm. In the visual alarm, a display color of the first alarm may be different from a display color of the second alarm, and, in the auditory alarm, a sound of the first alarm may be different from a sound of the second alarm.

[0051] The alarm may be a technical alarm which is output when the biological information monitoring apparatus, a sensor for measuring the biological information that includes at least one of an oxygen saturation, a blood pressure, an electrocardiogram, and respiration, or an interface between the sensor and the patient is abnormal, or a reception of a wireless signal is failed.

[0052] The second priority may be higher in priority than the first priority.

[0053] The first priority may be higher in priority than the second priority.

[0054] In order to achieve the object, according to the invention, there is also provided an alarm control method comprising: outputting a first alarm of a first priority when a first condition is satisfied, and when a second condition is satisfied after outputting the first alarm, changing from the first alarm to a second alarm of a second priority to be output.

#### BRIEF DESCRIPTION OF THE DRAWINGS

[0055] Fig. 1 is a view showing the appearance of a biological information monitoring apparatus of the station type which is placed in a nurse's station or the like, and in which biological signals of a plurality of patients can be simultaneously monitored.

[0056] Fig. 2 is a view illustrating an example of an alarm priority change in the invention in the case where the state of the alarm satisfies predetermined conditions, by using an example of a measurement of the oxygen saturation (SpO<sub>2</sub>).

[0057] Fig. 3 is a view illustrating an example of an alarm priority change in the invention in the case where the state of the alarm escapes from predetermined conditions (an abnormal state).

#### DETAILED DESCRIPTION OF EMBODIMENTS

[0058] The configuration of the invention will be described with reference to Fig. 2.

[0059] Fig. 2 illustrates an example of an alarm priority change, by an alarm controller of a biological information monitoring apparatus in the invention, in which the priority of an alarm is changed (the alarm is changed) in the case where the state of the alarm satisfies predetermined conditions, by using an example of a measurement of the oxygen saturation (SpO<sub>2</sub>).

[0060] Fig. 2 shows the case where a measured value of the SpO<sub>2</sub> is reduced with falling below 90% which is a preset lower limit value.

[0061] In Fig. 2, the priority change of the SpO<sub>2</sub> alarm is set in the following manner. As illustrated, as the reduction

value (the threshold at which an abnormal state advances, and which indicates a dangerous state) from the lower limit value, -10% is set among OFF, -3%, -5%, and -10%, and, as the continuous time period of the reduction from the lower limit value, 5m (minutes) is set among OFF, 1m (minute), 2m (minutes), 3m (minutes), 5m (minutes), and 10m (minutes).

**[0062]** Each of the settings of the continuous time period and the reduction value from the lower limit value can be selected from a plurality of values.

**[0063]** The reduction value from the lower limit value can be set as a rate (%) or a fixed value (in the example, -10%), and may be automatically changed in an interlocked manner with the setting of the lower limit value. When the setting is changed in an interlocked manner, a change of the alarm priority can be automatically set while a medical person is not particularly conscious of minor settings.

**[0064]** The alarm levels (priorities) are set in the following manner. The normal SpO2 alarm is set to M level among H, M, and L levels, and the SpO2 alarm after the priority is changed is set to H level among H and M levels.

**[0065]** When, in this state, the measured value of the SpO2 is reduced and falls below 90% which is the lower limit value, the normal SpO2 alarm is generated, and the alarm of the medium priority configured by a visual alarm (yellow indicator display) and an auditory alarm (pulses of 150 to 1,000 Hz, and the duration time of 125 to 250 ms) is generated.

**[0066]** In the invention, as described above, the priority change of the SpO2 is set so that, as illustrated, -10% is set as the reduction value from the lower limit value, among OFF, -3%, -5%, and -10%, and 5m (minutes) is set as the continuous time period of the reduction from the lower limit value, among OFF, 1m (minute), 2m (minutes), 3m (minutes), 5m (minutes), and 10m (minutes). In the case where, even when the measured value of the SpO2 is reduced with falling below 90% which is the lower limit value, this state exceeds five minutes which is the set value of the continuous time period of the SpO2 alarm, the measured value of the SpO2 is not increased above the lower limit as shown by (a) in Fig. 2, the priority is escalated (changed), and the alarm level is switched to the alarm of the high priority.

**[0067]** Also in the case where, as shown by (b) in Fig. 2, the measured value of the SpO2 is further reduced with falling below 90% which is the lower limit value to exceed 10% which is the reduction value from the lower limit value (90 - 10 = 80%: a lower limit value of escalation which is the threshold which indicates a dangerous state), the priority is escalated (changed), and the alarm level is switched to the alarm of the high priority in a similar manner as described above.

**[0068]** In the case where the measured value of the SpO2 falls below 90% which is the lower limit value, the alarm of the medium priority is originally to be continued. In the invention, as described above, when the predetermined conditions are satisfied, the alarm level is switched to the alarm of the high priority. Therefore, attention is raised by, increasing the volume of an audio alarm (auditory alarm), or increasing the blinking rate of a blinking alarm (visual alarm), as compared with that of the medium priority. As shown in Table 2, in the visual alarm, a color of an indicator light (a display color) may be changed depending on the priority of the alarm. In addition, as shown in Table 4, in the auditory alarm, a sound may be changed depending on the priority of the alarm.

**[0069]** In the case where, after the priority of the SpO2 alarm is changed to the high priority, the measured value of the SpO2 returns within the set value of the lower limit of the priority change, in other words, the measured value of the SpO2 exceeds the lower limit value of escalation (i.e., in the case where the patient escapes from the dangerous state and returns to the abnormal state), as shown in Fig. 3, the priority of the SpO2 alarm is de-escalated (changed) to the alarm of the medium priority.

**[0070]** In Fig. 2, as illustrated, the priority change of the SpO2 alarm is set for example so that, as the reduction value from the lower limit value, -10% is set among OFF, -3%, -5%, and -10%, and, as the continuous time period of the reduction from the lower limit value, 5m (minutes) is set among OFF, 1m (minute), 2m (minutes), 3m (minutes), 5m (minutes), and 10m (minutes). These set values can be adequately changed.

**[0071]** Moreover, values other those in Fig. 2 can be set.

**[0072]** Although, in Fig. 2, the description is made by using the example of the alarm of SpO2, also the priority of an alarm with respect to a measured value other than SpO2, such as measured values of other biological signals, for example, measurements of the non-invasive blood pressure (NIBP), the electrocardiogram (ECG), and the respiration (RESP) can be changed.

**[0073]** In Fig. 2, the description is made by exemplifying the vital alarm of SpO2 which is a biological signal. Also with respect to a technical alarm which is generated by, for example, a failure of a biological signal measuring apparatus, checking of a probe, disabled pulse wave detection, an interruption of the radio wave (a wireless signal), or a failure of reception of a wireless signal, the priority of the alarm can be changed in the case where the predetermined conditions are satisfied.

**[0074]** Next, a setting example of the alarm priority change in the invention will be described with reference to Table 5.

EP 2 311 369 A1

Table 5 Conditions for generating escalation alarm

Kind	Parameter	Alarm item	Setting of escalation alarm								
			Setting of generating conditions						Normal level	Escalation level	
Vital alarm	SpO2	Reduction value from lower limit value	OFF	-3%	-5%	-10%			H/(M)/L	M	(H)
			Continuous time period								
		Continuous time period of reduction from lower limit value	OFF	1m	2m	3m	5m	10m	H/(M)/L	M	(H)
	RESP	APNEA time	OFF	20s	40s	60s			H/(M)/L	M	(H)
Technical alarm	SpO2	Probe check	OFF	1m	2m	3m	5m	10m	M/(L)	(M)	H
		Disabled pulse wave detection	OFF	1m	2m	3m	5m	10m	M/(L)	(M)	H
	ECG	Electrode check	OFF	1m	2m	3m	5m	10m	M/(L)	(M)	H
		Disabled analysis (noises)	OFF	1m	2m	3m	5m	10m	(M)/L	M	(H)
	Tele-meter	Interruption of radio wave (wireless signal)	OFF	1m	2m	3m	5m	10m	M/(L)	(M)	H
		Battery replacement	OFF	1m	10m	30m	60m	120m	M/(L)	(M)	H
									Escalation level is set to only level higher than normal		

Table 5 shows an example of conditions for generating the alarm priority change in the invention.

**[0075]** In Table 5, as the parameter and alarm item of a vital alarm, in SpO2, the reduction value from the lower limit value is configured so as to be set from candidates of OFF, -3%, -5%, and -10%.

**[0076]** Furthermore, in the SpO2, the continuous time period of the reduction from the lower limit value is configured so as to be set from candidates of OFF, 1m, 2m, 3m, 5m, and 10m.

**[0077]** As the parameter and alarm item of a vital alarm, in RESP (respiration), APNEA time is configured so as to be set from candidates of OFF, 20s, 40s, and 60s.

**[0078]** As the parameter and alarm item of a technical alarm, in SpO2, the probe check and the disabled pulse wave detection are configured so as to be set from candidates of OFF, 1m, 2m, 3m, 5m, and 10m.

**[0079]** As the parameter and alarm item of a technical alarm, in ECG (electrocardiogram), the electrode check and the disabled analysis (noises) are configured so as to be set from candidates of OFF, 1m, 2m, 3m, 5m, and 10m.

**[0080]** As the parameter and alarm item of a technical alarm, in the telemeter, the interruption of the radio wave (a wireless signal) is configured so as to be set from candidates of OFF, 1m, 2m, 3m, 5m, and 10m.

**[0081]** Furthermore, in the telemeter, the battery replacement is configured so as to be set from candidates of OFF, 1m, 10m, 30m, 60m, and 120m.

**[0082]** In Table 5, as alarm priorities before and after the priorities of vital and technical alarms are changed, a normal

level and a level after the change of the priority are shown.

[0083] In Table 5, in SpO<sub>2</sub>, for example, the normal level (M) is changed to (H) after the priority is changed. As illustrated, the changed priority level can be set to be higher than the normal level. This is employed because an alarm of a higher level is generated so as to prevent the nurse or the like from overlooking the alarm.

[0084] Although, in Table 5, as examples of the alarm and the alarm item, two items, the SpO<sub>2</sub> and the RESP are listed with respect to the vital alarm, and three items, the SpO<sub>2</sub>, the ECG, and the telemeter are listed with respect to the technical alarm, it is obvious that the concept of the invention can be applied also to vital and technical alarms other than the above-described ones.

[0085] In Fig. 2, the example of the priority change of the vital alarm of SpO<sub>2</sub> which is a biological signal is described. However, technical alarms of a failure of a biological signal measuring apparatus, checking of a probe, disabled pulse wave detection, an interruption of the radio wave (a wireless signal), and the like are also important in the invention. A generation of a technical alarm is performed in the case of a failure of a biological signal measuring apparatus itself, checking of a probe, disabled pulse wave detection, an interruption of the radio wave (a wireless signal), a failure of reception of a wireless signal, and the like. In the case where a failure of a biological signal measuring apparatus itself, checking of a probe, disabled pulse wave detection, an interruption of the radio wave (a wireless signal), a failure of reception of a wireless signal, and the like occurs, therefore, a technical alarm is generated.

[0086] A generation of a technical alarm means that a failure of a biological signal measuring apparatus itself, a state where checking of a probe, disabled pulse wave detection, an interruption of the radio wave (a wireless signal), a failure of reception of a wireless signal, or the like occurs. However, this is not directly related to a phenomenon in which an abnormality is caused in the biological signal of the patient. Therefore, there arises a problem in that, even when a technical alarm is continued, the nurse or the like overlooks the alarm,

[0087] During a period when a technical alarm is continued, the biological signal of the patient cannot be correctly measured. This may cause a serious abnormality of the biological signal of the patient to be overlooked.

[0088] In the invention, when a technical alarm is continued for a predetermined time period, therefore, the priority of the alarm is changed, and an alarm of a different priority is generated. Consequently, an escalation alarm attains an excellent effect in preventing a serious abnormality of the biological signal of the patient from being overlooked.

[0089] In a surgery room or the like from which the patient leaves, the measurement is not correctly performed, and hence a technical alarm (sometimes, a vital alarm) is often generated. In the invention, when a predetermined time period elapses, an alarm of higher priority may be sometimes announced. This situation is not desirable.

[0090] In the biological information monitoring apparatus, therefore, an inputting unit (not shown) through which the user directly operates the alarm controller may be disposed, and the user may operate the inputting unit, whereby an alarm of a high priority is de-escalated (changed) to that of a lower priority. According to the configuration, the above-described undesirable situation can be avoided.

[0091] The function of changing the alarm priority of the invention is provided in the biological information monitoring apparatus of the station type in which biological signals of a plurality of patients can be simultaneously monitored, as shown in Fig. 1. Also, the function of changing the alarm priority of the invention may be provided in a bedside biological information monitoring apparatus in which a patient in a medical ward or the like is individually monitored. According to an aspect of the invention, in the case where, after a vital alarm that is output in abnormality of a biological signal, or a technical alarm that is output in abnormality of the biological information monitoring apparatus, a sensor, or the measurement environment is produced, the alarm is continued at the same priority, the priority of the alarm can be changed (for example, from the medium priority to the high priority) when the alarm state satisfies predetermined conditions.

## Claims

1. A biological information monitoring apparatus operable to measure biological information of a patient by detecting a biological signal of the patient, and operable to output an alarm, the biological information monitoring apparatus comprising:

an alarm controller which changes the alarm, wherein  
the alarm includes a first alarm of a first priority and a second alarm of a second priority, wherein  
when a first condition is satisfied, the first alarm is output, and  
when a second condition is satisfied after the first alarm is output, the alarm controller changes from the first alarm to the second alarm to be output.

2. The biological information monitoring apparatus according to claim 1, wherein  
the alarm including the first alarm and the second alarm is a technical alarm which is output when the biological information monitoring apparatus, a sensor for measuring the biological information, or measurement environment

is abnormal, and

the second condition is a condition that an abnormal state in which the biological information monitoring apparatus, the sensor, or the measurement environment is abnormal is continued for a time period.

- 5     **3.** The biological information monitoring apparatus according to claim 1, wherein  
the alarm including the first alarm and the second alarm is a vital alarm which is output when the detected biological  
signal is abnormal, and  
the second condition is at least one of a condition that an abnormal state in which the detected biological signal is  
abnormal is continued for a time period and a condition that the detected biological signal passes a threshold  
10     indicating a dangerous state.
- 4.** The biological information monitoring apparatus according to claim 1, further comprising:  
  
an inputting unit, wherein  
15     after the alarm controller changes from the first alarm to the second alarm, a user operates the inputting unit to  
change from the second alarm to the first alarm to be output.
- 5.** The biological information monitoring apparatus according to claim 1, wherein  
the alarm including the first alarm and the second alarm is a vital alarm which is output when the detected biological  
20     signal is abnormal, and  
in a case where, after the alarm controller changes from the first alarm to the second alarm, the detected biological  
signal passes a threshold to an area indicating a dangerous state, and the detected biological signal returns from  
the area and passes the threshold, the alarm controller changes from the second alarm to the first alarm to be output.
- 25     **6.** The biological information monitoring apparatus according to claim 3, wherein  
the first condition is a condition that the detected biological signal passes a threshold, and  
the threshold of the second condition is set with being interlocked with setting of the threshold of the first condition.
- 7.** The biological information monitoring apparatus according to claim 3, wherein  
30     each of the time period and the threshold is set from a plurality of candidate values.
- 8.** The biological information monitoring apparatus according to claim 1, wherein  
the alarm including the first alarm and the second alarm includes at least one of a visual alarm and an auditory  
alarm, and  
35     in the visual alarm, a blinking rate in the second alarm is set higher than a blinking rate in the first alarm, and, in the  
auditory alarm, a volume in the second alarm is set higher than a volume in the first alarm.
- 9.** The biological information monitoring apparatus according to claim 1, wherein  
the alarm including the first alarm and the second alarm includes at least one of a visual alarm and an auditory  
40     alarm, and  
in the visual alarm, a blinking rate in the second alarm is set lower than a blinking rate in the first alarm, and, in the  
auditory alarm, a volume in the second alarm is set lower than a volume in the first alarm.
- 10.** The biological information monitoring apparatus according to claim 1, wherein  
45     the alarm including the first alarm and the second alarm includes at least one of a visual alarm and an auditory  
alarm, and  
in the visual alarm, a display color of the first alarm is different from a display color of the second alarm, and, in the  
auditory alarm, a sound of the first alarm is different from a sound of the second alarm.
- 50     **11.** The biological information monitoring apparatus according to claim 1, wherein  
the alarm is a technical alarm which is output when the biological information monitoring apparatus, a sensor for  
measuring the biological information that includes at least one of an oxygen saturation, a blood pressure, an elec-  
trocardiogram, and respiration, or an interface between the sensor and the patient is abnormal, or a reception of a  
wireless signal is failed.
- 55     **12.** The biological information monitoring apparatus according to claim 1, wherein  
the second priority is higher in priority than the first priority.

**EP 2 311 369 A1**

**13.** The biological information monitoring apparatus according to claim 1, wherein the first priority is higher in priority than the second priority.

**14.** An alarm control method comprising:

5                   outputting a first alarm of a first priority when a first condition is satisfied, and  
10                   when a second condition is satisfied after outputting the first alarm, changing from the first alarm to a second alarm  
of a second priority to be output.

10

15

20

25

30

35

40

45

50

55

FIG. 1

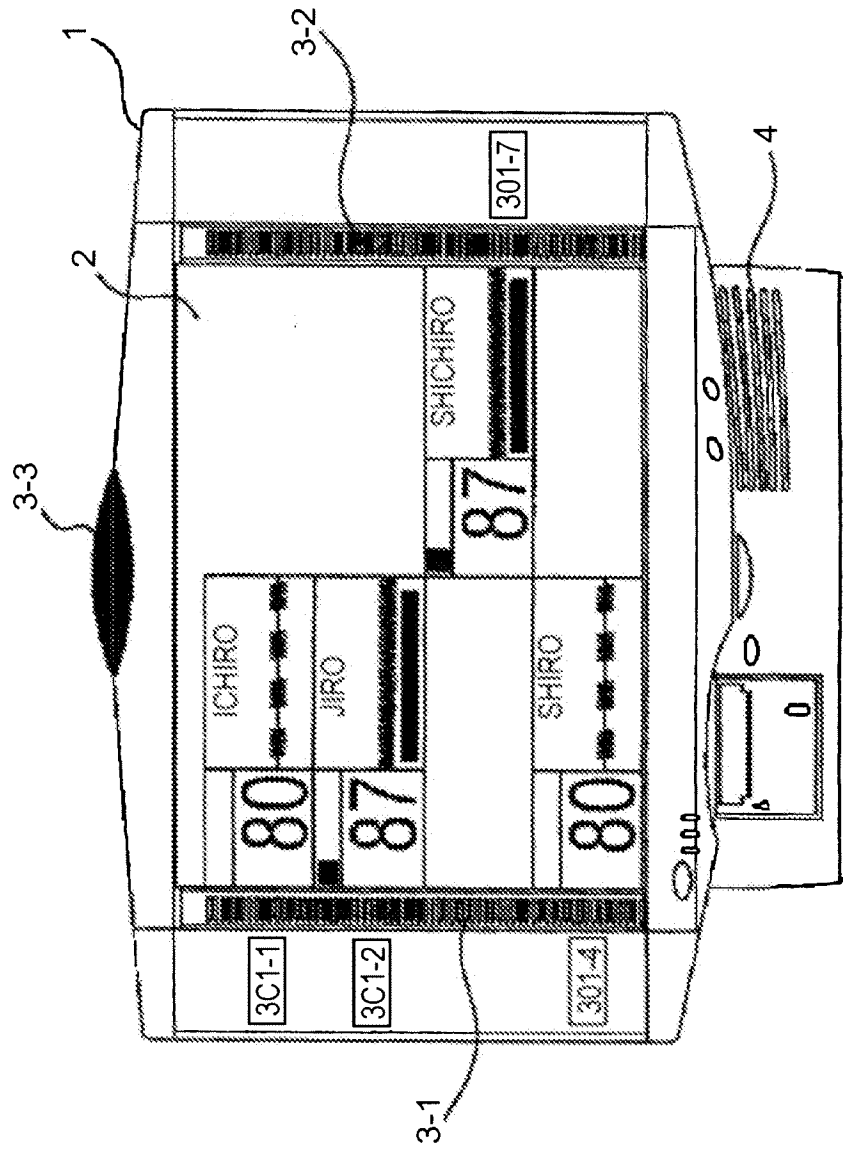
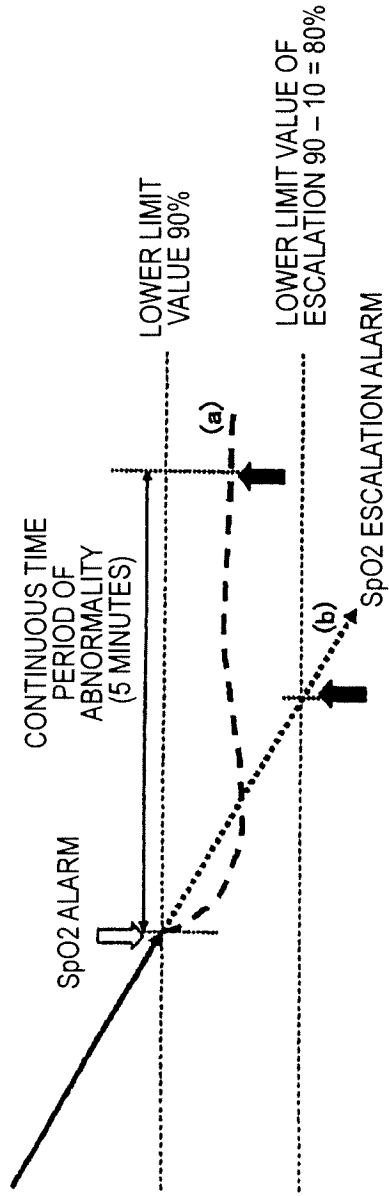
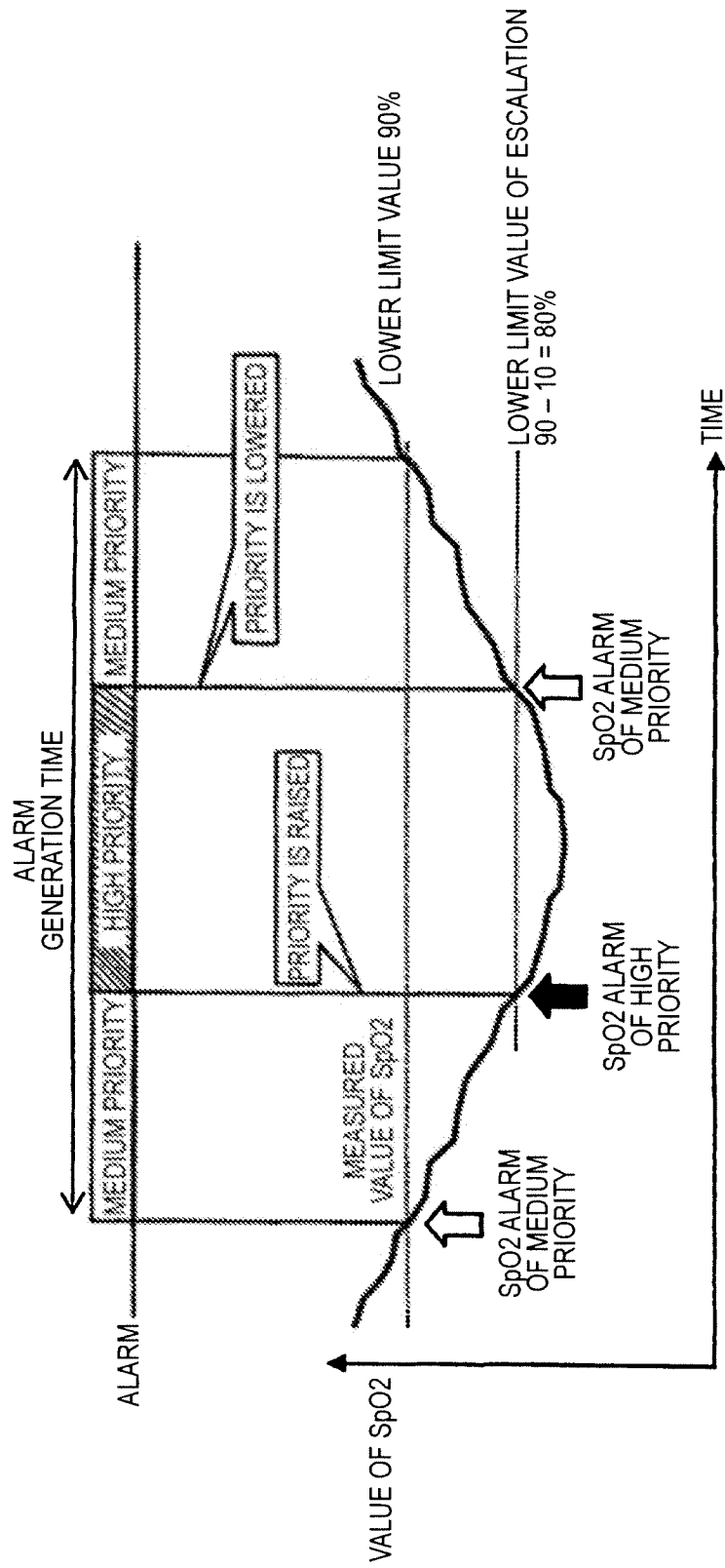

FIG. 2



SETTING OF SpO2 ESCALATION ALARM		SETTING OF ALARM LEVEL			
REDUCTION VALUE FROM LOWER LIMIT VALUE	SET CONDITIONS	SpO2 ALARM	H	M	L
OFF	-3% -5%	<input type="radio"/>	<input type="radio"/>	<input checked="" type="radio"/>	<input checked="" type="radio"/>
CONTINUOUS TIME PERIOD OF REDUCTION FROM LOWER LIMIT VALUE	OFF 1m 2m 3m 5m 10m	<input type="radio"/>	<input checked="" type="radio"/>	<input checked="" type="radio"/>	<input checked="" type="radio"/>
		SpO2 ESCALATION ALARM			

FIG. 3





EUROPEAN SEARCH REPORT

Application Number  
EP 10 18 6856

DOCUMENTS CONSIDERED TO BE RELEVANT			
Category	Citation of document with indication, where appropriate, of relevant passages	Relevant to claim	CLASSIFICATION OF THE APPLICATION (IPC)
X	US 2009/221887 A1 (MANNHEIMER PAUL D [US] ET AL) 3 September 2009 (2009-09-03) * abstract; claims 1,21,22; figures 1-3 * * paragraphs [0013] - [0016], [0020], [0024] - [0026] * -----	1-14	INV. A61B5/00
X	US 2008/094227 A1 (BECKER UWE [DE] ET AL) 24 April 2008 (2008-04-24) * abstract; figure 1 * * paragraphs [0011], [0014], [0015], [0021] - [0024], [0 27] - [0028] * * claims 1,2,3,5,6-10 * -----	1-14	
X	US 5 786 755 A (CICCHINO DOMENIC A [US] ET AL) 28 July 1998 (1998-07-28) * abstract; figure 2 * -----	14	
A	US 2009/247851 A1 (BATCHELDER KEITCH [US] ET AL) 1 October 2009 (2009-10-01) * the whole document * -----	1-14	
			TECHNICAL FIELDS SEARCHED (IPC)
			A61B
The present search report has been drawn up for all claims			
Place of search Munich		Date of completion of the search 28 January 2011	Examiner Daniel, Christian
CATEGORY OF CITED DOCUMENTS X : particularly relevant if taken alone Y : particularly relevant if combined with another document of the same category A : technological background O : non-written disclosure P : intermediate document		T : theory or principle underlying the invention E : earlier patent document, but published on, or after the filing date D : document cited in the application L : document cited for other reasons ..... & : member of the same patent family, corresponding document	

2  
EPO FORM 1503 03.82 (POAC01)

**ANNEX TO THE EUROPEAN SEARCH REPORT  
ON EUROPEAN PATENT APPLICATION NO.**

EP 10 18 6856

This annex lists the patent family members relating to the patent documents cited in the above-mentioned European search report.  
The members are as contained in the European Patent Office EDP file on  
The European Patent Office is in no way liable for these particulars which are merely given for the purpose of information.

28-01-2011

Patent document cited in search report	Publication date	Patent family member(s)	Publication date
US 2009221887 A1	03-09-2009	EP 1932126 A1	18-06-2008
		JP 2009510631 T	12-03-2009
		US 2007106126 A1	10-05-2007
		WO 2007041329 A1	12-04-2007
US 2008094227 A1	24-04-2008	DE 102006049137 A1	30-04-2008
US 5786755 A	28-07-1998	NONE	
US 2009247851 A1	01-10-2009	NONE	

**REFERENCES CITED IN THE DESCRIPTION**

*This list of references cited by the applicant is for the reader's convenience only. It does not form part of the European patent document. Even though great care has been taken in compiling the references, errors or omissions cannot be excluded and the EPO disclaims all liability in this regard.*

**Patent documents cited in the description**

- JP 2009101214 A [0002]

专利名称(译)	生物信息监测装置和报警控制方法		
公开(公告)号	<a href="#">EP2311369A1</a>	公开(公告)日	2011-04-20
申请号	EP2010186856	申请日	2010-10-07
[标]申请(专利权)人(译)	日本光电工业株式会社		
申请(专利权)人(译)	日本光电公司		
当前申请(专利权)人(译)	日本光电公司		
[标]发明人	TANISHIMA MASAMI ECHIGO MASAHIRO OYAGI RIE TEZUKA SHINJI ENOMOTO YOSHINORI		
发明人	TANISHIMA, MASAMI ECHIGO, MASAHIRO OYAGI, RIE TEZUKA, SHINJI ENOMOTO, YOSHINORI		
IPC分类号	A61B5/00		
CPC分类号	A61B5/746 A61B5/1455 A61B2560/0276		
优先权	2009233153 2009-10-07 JP		
外部链接	<a href="#">Espacenet</a>		

摘要(译)

一种生物信息监测装置，其可操作以通过检测患者的生物信号来测量患者的生物信息，并且可操作以输出警报，包括改变警报的警报控制器。警报包括第一优先级的第一警报和第二优先级的第二警报。当满足第一条条件时，输出第一个警报。在输出第一个警报后满足第二个条件时，警报控制器从第一个警报变为第二个警报输出。

FIG. 1

