



(12) **EUROPEAN PATENT APPLICATION**

(88) Date of publication A3:  
**20.06.2007 Bulletin 2007/25**

(51) Int Cl.:  
**A61B 5/00 (2006.01)**

(43) Date of publication A2:  
**21.03.2007 Bulletin 2007/12**

(21) Application number: **06254869.8**

(22) Date of filing: **20.09.2006**

(84) Designated Contracting States:  
**AT BE BG CH CY CZ DE DK EE ES FI FR GB GR HU IE IS IT LI LT LU LV MC NL PL PT RO SE SI SK TR**  
 Designated Extension States:  
**AL BA HR MK YU**

(71) Applicant: **PACESETTER, INC.**  
**Sylmar, CA 91342-9221 (US)**

(72) Inventor: **Poore, John W.**  
**South Pasadena, CA 91030 (US)**

(74) Representative: **Rees, David Christopher et al**  
**Kilburn & Strode**  
**20 Red Lion Street**  
**London WC1R 4PJ (GB)**

(30) Priority: **17.11.2005 US 282198**  
**20.09.2005 US 231555**

(54) **Implantable self-calibrating optical sensors**

(57) A measurement light detector detects light transmitted by a light source (104,106,108) of an implantable system that is scattered back into an implantable housing (804), and produces a measurement signal indicative of the intensity of the light detected by the measurement light detector (806). A calibration light detector (1106) detects a portion of the transmitted light that has

not exited the housing (804), and produces a calibration signal (1132) that is indicative of the intensity of the light detected by the calibration light detector (1106), which is indicative of the intensity of the light transmitted by the light source. Changes in the intensity of the transmitted light are compensated for based on the calibration signal (1132) produced by the calibration light detector (106).

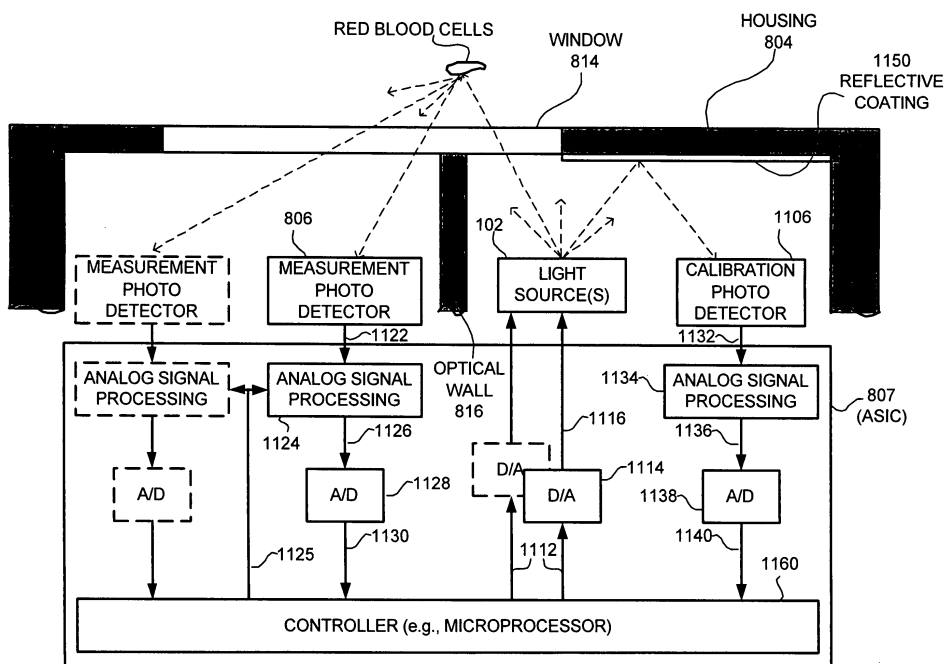

**FIG. 11A**



DOCUMENTS CONSIDERED TO BE RELEVANT			
Category	Citation of document with indication, where appropriate, of relevant passages	Relevant to claim	CLASSIFICATION OF THE APPLICATION (IPC)
X	WO 00/25860 A (MEDTRONIC INC [US]) 11 May 2000 (2000-05-11) * page 22, line 8 - line 16 * * page 23, line 8 - page 25, line 17 * * figure 10 * -----	1-17	INV. A61B5/00
			TECHNICAL FIELDS SEARCHED (IPC)
			A61B
The present search report has been drawn up for all claims			
Place of search		Date of completion of the search	Examiner
Munich		16 May 2007	Hooper, Martin
CATEGORY OF CITED DOCUMENTS X : particularly relevant if taken alone Y : particularly relevant if combined with another document of the same category A : technological background O : non-written disclosure P : intermediate document T : theory or principle underlying the invention E : earlier patent document, but published on, or after the filing date D : document cited in the application L : document cited for other reasons ..... & : member of the same patent family, corresponding document			

3

EPO FORM 1503 03 82 (P04C01)

**ANNEX TO THE EUROPEAN SEARCH REPORT  
ON EUROPEAN PATENT APPLICATION NO.**

EP 06 25 4869

This annex lists the patent family members relating to the patent documents cited in the above-mentioned European search report. The members are as contained in the European Patent Office EDP file on  
The European Patent Office is in no way liable for these particulars which are merely given for the purpose of information.

16-05-2007

Patent document cited in search report	Publication date	Patent family member(s)	Publication date
WO 0025860 A	11-05-2000	US 6125290 A	26-09-2000
-----			

EPO FORM P0459

For more details about this annex : see Official Journal of the European Patent Office, No. 12/82

专利名称(译)	可植入的自校准光学传感器		
公开(公告)号	<a href="#">EP1764034A3</a>	公开(公告)日	2007-06-20
申请号	EP2006254869	申请日	2006-09-20
[标]申请(专利权)人(译)	标兵		
申请(专利权)人(译)	PACESETTER, INC.		
当前申请(专利权)人(译)	PACESETTER, INC.		
[标]发明人	POORE JOHN W		
发明人	POORE, JOHN W.		
IPC分类号	A61B5/00		
CPC分类号	A61B5/14542 A61B5/14535 A61B5/1459 A61B5/1495		
代理机构(译)	里斯DAVID CHRISTOPHER		
优先权	11/231555 2005-09-20 US 11/282198 2005-11-17 US		
其他公开文献	EP1764034A2 EP1764034B1		
外部链接	<a href="#">Espacenet</a>		

摘要(译)

测量光检测器检测由可植入系统的光源 ( 104,106,108 ) 传输的光, 该光被散射回可植入壳体 ( 804 ), 并产生指示由测量光检测器检测到的光强度的测量信号 ( 806 )。 )。校准光检测器 ( 1106 ) 检测未离开壳体 ( 804 ) 的透射光的一部分, 并产生校准信号 ( 1132 ), 该校准信号指示校准光检测器 ( 1106 ) 检测到的光的强度。 , 这表示光源透射的光的强度。基于校准光检测器 ( 106 ) 产生的校准信号 ( 1132 ) 补偿透射光强度的变化。

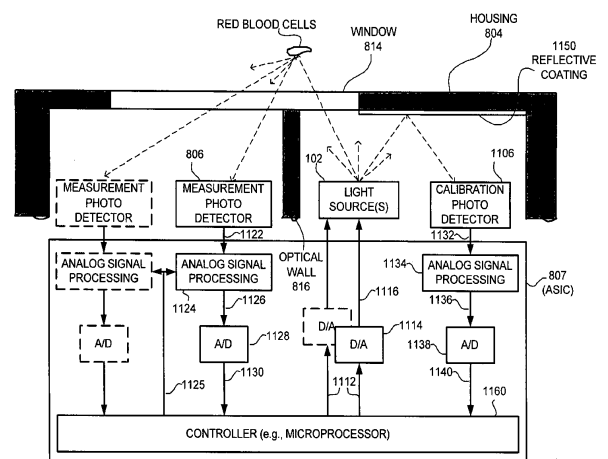

FIG. 11A