

(19) World Intellectual Property Organization  
International Bureau



(43) International Publication Date  
13 November 2003 (13.11.2003)

PCT

(10) International Publication Number  
WO 03/092491 A1

- (51) International Patent Classification<sup>7</sup>: **A61B 5/02**
- (21) International Application Number: PCT/AU03/00526
- (22) International Filing Date: 5 May 2003 (05.05.2003)
- (25) Filing Language: English
- (26) Publication Language: English
- (30) Priority Data:  
PS 2145 6 May 2002 (06.05.2002) AU
- (71) Applicant (for all designated States except US): **USCOM PTY LTD** [AU/AU]; 323 Old Coast Road, Korora, New South Wales 2450 (AU).
- (72) Inventor; and
- (75) Inventor/Applicant (for US only): **PHILLIPS, Robert, Allan** [AU/AU]; P O Box J241, Coffs Harbour, NSW 2450 (AU).
- (74) Agent: **BALDWIN SHELSTON WATERS**; 60 Margaret Street, Sydney, NSW 2000 (AU).
- (81) Designated States (national): AE, AG, AL, AM, AT, AU, AZ, BA, BB, BG, BR, BY, BZ, CA, CH, CN, CO, CR, CU, CZ, DE, DK, DM, DZ, EC, EE, ES, FI, GB, GD, GE, GH, GM, HR, HU, ID, IL, IN, IS, JP, KE, KG, KP, KR, KZ, LC, LK, LR, LS, LT, LU, LV, MA, MD, MG, MK, MN, MW, MX, MZ, NI, NO, NZ, OM, PH, PL, PT, RO, RU, SC, SD, SE, SG, SK, SL, TJ, TM, TN, TR, TT, TZ, UA, UG, US, UZ, VC, VN, YU, ZA, ZM, ZW.
- (84) Designated States (regional): ARIPO patent (GH, GM, KE, LS, MW, MZ, SD, SL, SZ, TZ, UG, ZM, ZW), Eurasian patent (AM, AZ, BY, KG, KZ, MD, RU, TJ, TM), European patent (AT, BE, BG, CH, CY, CZ, DE, DK, EE, ES, FI, FR, GB, GR, HU, IE, IT, LU, MC, NL, PT, RO, SE, SI, SK, TR), OAPI patent (BF, BJ, CF, CG, CI, CM, GA, GN, GQ, GW, ML, MR, NE, SN, TD, TG).

[Continued on next page]

(54) Title: BLOOD FLOW OXYGEN MEASUREMENT SYSTEM AND METHOD

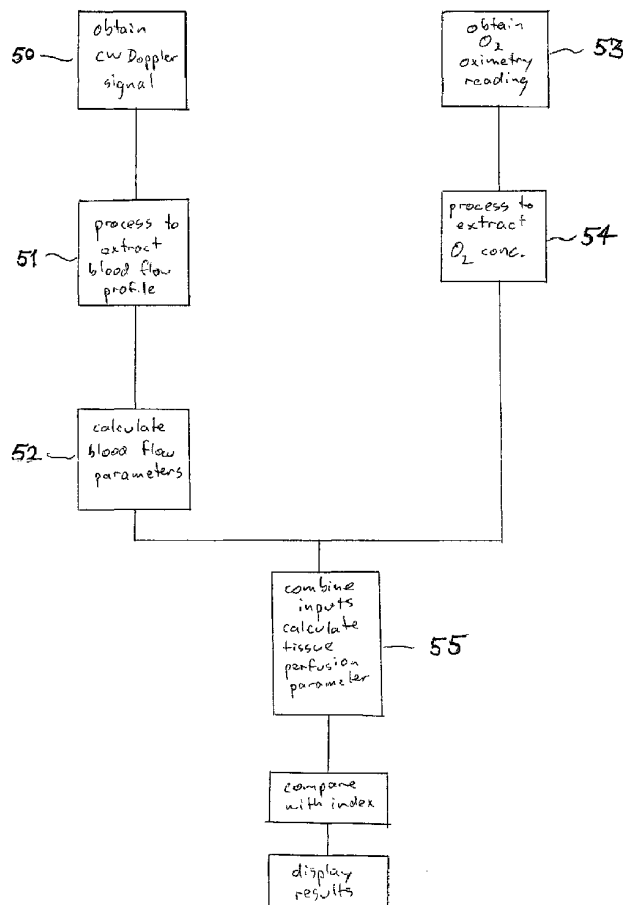

(57) Abstract: An apparatus for measuring physiologic tissues perfusion information including: a first device producing a first output indicative of blood flow of a patient; a second device producing a second output indicative of oxygen content of the blood; and a processor combining said first and said second outputs to produce a third output indicative of tissue perfusion.



WO 03/092491 A1

**Declarations under Rule 4.17:**

- as to applicant's entitlement to apply for and be granted a patent (Rule 4.17(ii)) for the following designations AE, AG, AL, AM, AT, AU, AZ, BA, BB, BG, BR, BY, BZ, CA, CH, CN, CO, CR, CU, CZ, DE, DK, DM, DZ, EC, EE, ES, FI, GB, GD, GE, GH, GM, HR, HU, ID, IL, IN, IS, JP, KE, KG, KP, KR, KZ, LC, LK, LR, LS, LT, LU, LV, MA, MD, MG, MK, MN, MW, MX, MZ, NI, NO, NZ, OM, PH, PL, PT, RO, RU, SC, SD, SE, SG, SK, SL, TJ, TM, TN, TR, TT, TZ, UA, UG, UZ, VC, VN, YU, ZA, ZM, ZW, ARIPO patent (GH, GM, KE, LS, MW, MZ, SD, SL, SZ, TZ, UG, ZM, ZW), Eurasian patent (AM, AZ, BY, KG, KZ, MD, RU, TJ, TM), European

patent (AT, BE, BG, CH, CY, CZ, DE, DK, EE, ES, FI, FR, GB, GR, HU, IE, IT, LU, MC, NL, PT, RO, SE, SI, SK, TR), OAPI patent (BF, BJ, CF, CG, CI, CM, GA, GN, GQ, GW, ML, MR, NE, SN, TD, TG)

- of inventorship (Rule 4.17(iv)) for US only

**Published:**

- with international search report

For two-letter codes and other abbreviations, refer to the "Guidance Notes on Codes and Abbreviations" appearing at the beginning of each regular issue of the PCT Gazette.

# Blood flow oxygen measurement system and method

## Field of the invention

This invention relates to measurement and monitoring of vital physiological  
5 tissue perfusion information.

## Background of the invention

Tissues requires oxygen for life and this is supplied by the stream of blood  
which transports dissolved oxygen to the cells. The amount of oxygen reaching the  
tissues is a function of the volume of blood pumped by the heart and the oxygen content  
10 of the blood. Hereto before there has been no device producing a single output  
indicative of tissue perfusion and no ready measure for correlating a reading of tissue  
perfusion with the presence or absence of a condition within a patient.

## Summary of the invention

It is an object of the present invention to provide an improved blood oxygen  
15 measurement method and apparatus.

In a first aspect of the present invention there is provided an apparatus for  
measuring physiologic tissues perfusion information including:

a first device producing a first output indicative of blood flow of a patient;

a second device producing a second output indicative of oxygen content of the  
20 blood; and

a processor combining said first and said second outputs to produce a third  
output indicative of tissue perfusion.

In a preferred embodiment, the first device uses a CW Doppler method to  
measure blood flow. The second device can use oximetry to measure oxygen content.

25 In a preferred embodiment the third output is indicative of at least one of  
percent distance (stroke saturation), percent minute distance (saturation output), percent

In a preferred embodiment the third output is indicative of at least one of percent distance (stroke saturation), percent minute distance (saturation output), percent stroke volume (saturation stroke volume) and percent output (saturation output).

5 In a preferred embodiment, the apparatus combines into cardiac or aortic flow with peripheral oximetry.

In a second aspect, the invention provides a method of measuring physiologic tissue perfusion information including obtaining a measurement of blood flow and a measurement of blood oxygen content, and combining said measurements to produce an output indicative of tissue perfusion.

10 In a further aspect, the invention provides a method of creating a tissue perfusion index including:

(a) obtaining a measurement of blood flow and a measurement of blood oxygen content from a patient;

15 (b) combining said measurements to calculate a parameter indicative of tissue perfusion in said patient;

(c) repeating steps (a) and (b) on a plurality of patients to obtain a set of calculations of said parameter for said plurality of patients;

(d) processing the set of calculated parameters to obtain a statistically averaged index of said parameter for a population.

20 In a further aspect, the invention provides a method of creating a tissue perfusion index for a healthy population including:

(a) obtaining a measurement of blood flow and a measurement of blood oxygen content from a healthy patient;

25 (b) combining said measurements to calculate a parameter indicative of tissue perfusion in said healthy patient;

(c) repeating steps (a) and (b) on a plurality of healthy patients to obtain a set of calculations of said parameter for said plurality of patients;

(d) processing the set of calculated parameters to obtain a statistically averaged index of said parameter for a healthy population.

In a further aspect, the invention provides a method of creating a systemic perfusion index for a population with a known condition including:

5 (a) obtaining a measurement of blood flow and a measurement of blood oxygen content from a patient with said known condition;

(b) combining said measurements to calculate a parameter indicative of tissue perfusion in said patient;

10 (c) repeating steps (a) and (b) on a plurality of patients with said known condition to obtain a set of calculations of said parameter for said plurality of patients;

(d) processing the set of calculated parameters to obtain a statistically averaged index of said parameter for a population with said known condition.

In a further aspect, the invention provides a method of diagnosing a condition in a patient including:

15 (a) obtaining a measurement of blood flow and a measurement of blood oxygen content from a patient;

(b) combining said measurements to calculate a parameter indicative of tissue perfusion in said patient;

20 (c) comparing said calculated parameter with a statistically averaged index of said parameter to determine the extent to which said condition exists within said patient.

### **Brief description of the drawings**

The invention will now be described by way of example only with reference to preferred embodiments and to the accompanying figures in which:

25 Fig. 1 shows an apparatus of a preferred embodiment connected to a patient;

Fig. 2 shows an ultrasonic device for measuring blood flow;

Fig. 3 shows an output from the device of Fig. 2;

Fig. 4 is a schematic of the signal processing aspects of the apparatus; and

Fig 5 is a flow diagram of the steps for producing a tissue perfusion reading.

### Detailed description of preferred embodiments

Referring to Fig. 1 there is shown a patient 10 to which is attached an apparatus in accordance with a preferred embodiment of the invention. The apparatus 10 includes a non-invasive blood flow monitor 11 and digital oximetry device 12.

The outputs of the blood flow 11 and the oximetry 12 devices are combined in a processor unit 20 which may be located adjacent the patient. The processor unit 20 includes a processor (internal) and display screen 22. Control keys 23 on the outside of the processor unit 20 can be used to select one or more tissue perfusion parameters to be calculated and displayed on the screen 22 as will be described in greater detail below. The processor unit may also receive inputs from external devices (not shown) such as a heart rate monitor and may also receive inputs entered manually by a user using control keys 23. Further, the processor unit can be in turn interconnected to a computer network for the transfer of information to and from the processor unit 20.

Fig. 2 shows an example of an actuator for attachment to the skin surface. Ideally CW Doppler is utilised to monitor blood flow. CW Doppler is a non-invasive technique in which ultrasonic signals from transducer elements are directed into a blood carrying vessel of a patient. Doppler shifts in the reflected signal provide an indication of the rate of blood flow. In Fig. 2, a transducer element 30 includes an ultrasonic transducer 31 attached to a positioning device 32 which can be used to initially set the position of the transducer. Between the transducer 31 and a patient's skin 34 is placed a gel coupling layer 33 for coupling the ultrasonic transducer vibrations to the skin 34. The principles of CW Doppler flow measurement are known and do not themselves form part of the present invention. Patent Cooperation Treaty (PCT) publication number WO 99/66835 to the present assignee, the contents of which are incorporated herein by cross-reference, described in more detail an ultrasonic transducer device suitable for measuring blood flow using the CW Doppler method. In the embodiment

shown in Fig. 1, the transducer elements are placed on the patient to obtain intra-cardiac or aortic signals, for example through the suprasternal notch.

The CW method detects the velocity of individual blood cells by measuring the frequency change of a reflected ultrasound beam and displaying this as a time velocity flow profile, an example of which is shown in Fig. 3. The transducer output forms an input to the processor unit 20. From the velocity time flow profile, the processor can calculate a velocity time integral (vti) and other relevant information such as heart rate (HR), and peak velocity, each of which is shown in Fig. 3.

Oximetry is a known method of measuring the oxygen saturation ( $O_2$ ) of blood. Latest transcutaneous oximetry devices using infra-red technology are made non-invasive and of small size. Examples include US Patents 6553241, 6542764, 2706927, 5632272. In the embodiment shown in Fig. 1, digital oximetry is used to obtain an oxygen concentration reading from a patient's finger. Persons skilled in the art are aware of adequate display drivers, displays, transducer drivers and transducers to utilise in view of the disclosures herein.

The processor unit receives the outputs of the blood flow monitor and the oximetry device. Heart rate may also be input into the processor from a separate heart rate monitor. Alternatively, the heart rate may be calculated from analysis of the blood flow profile, e.g. by counting the number of beat peaks over a period of time.

The processor mathematically combines its inputs to derive new parameters pertaining to tissue perfusion. A first derived measure is the percent distance stroke saturation (SS) and is a function of the oxygen saturation ( $O_2$ ) and the stroke distance measured as the velocity time integral (vti) of the blood flow profile over a single stroke:

$$SS = O_2 \times vti$$

The percent minute distance saturation output (SO) can be a function of oxygen saturation, stroke distance and heart rate (HR);

- 6 -

$$SS = O_2 \times vti \times HR.$$

Percent stroke volume (saturation stroke volume SSV) is a function of oxygen saturation, the time velocity integral from the blood flow profile and the Doppler flow profile cross sectional area (XSA) and can be calculated as follows:

5 
$$SS = O_2 \times vti \times XSA.$$

Percent stroke volume describes the volume of oxygen passing through body tissue per heartbeat.

Percent output (saturation output) is a function of oxygen saturation, the time velocity integral from the blood flow profile, the Doppler flow profile cross sectional  
10 area and the heart rate:

$$SSV = O_2 \times vti \times XSA \times HR.$$

Percent output describes the total volume of oxygen passing through the body tissue.

Analysis based on these new tissue perfusion parameters provide for an  
15 improved understanding of physiology and pathophysiology associated with cardiovascular function, exercise and pulmonary function. They can also facilitate new methods of categorising conditions and new methods of diagnosing conditions within a patient. Furthermore, these new parameters can also provide greater monitoring of conditions within a patient, e.g. during recovery, as the parameters can provide  
20 complete indications of tissue perfusion which relates directly to the ongoing health of the tissue.

The above benefits may be realised by the creation of tissue perfusion indices. For example, a tissue perfusion parameter produced by the combination of blood flow and oxygen concentration readings may be measured for a plurality of known healthy  
25 patients to determine an index for the parameter, which index denotes good health. The perfusion index can be established by measuring the parameter in a plurality of healthy patients and then statistically averaging the results to determine a value or range of values of the tissue perfusion parameter.

Similarly, the same parameter may be measured in a plurality of patients having a known condition to obtain a tissue perfusion index relating to that parameter, which index describes the presence of that condition.

Diagnosis of a condition in a patient can then be performed by calculating the parameter for the patient and comparing the result with the parameter indices to determine whether the condition exists in the patient.

Statistical averaging of the parameter values of individual patients may take into account such variables as age, sex, height, weight, ethnicity etc. The indices thereby produced may be scaled according to these factors, e.g. the upper and lower limits of a tissue perfusion parameter denoting good health may vary with age or there may be a different range of values depending on sex.

As the processor unit is able to perform a real time calculation of a tissue perfusion parameter, the preferred embodiment of the present invention allows for continuous monitoring and healthcare of a patient based on the tissue perfusion reading. For example, a patient in recovery may have tissue perfusion monitored in a relevant region of the body. If the tissue perfusion reaches a healthy range of the tissue perfusion index, then good health is indicated and treatment may be ceased or reduced. Conversely, the tissue perfusion reading of a patient may change to a healthy level. An alarm state may be triggered when the tissue perfusion reading crosses a threshold level so that corrective action, e.g. to the course of treatment, may be taken.

Fig. 4 shows, in functional block diagram form, one form of construction of the signal processing aspects of the apparatus. It will be evident to those skilled in the art of complex electronic system design that a hardware implementation of the preferred embodiment can take many different forms from standard programmed microprocessor or microprocessor arrangements to more customised arrangements including Field Programmable Gate Arrays (FPGAs) or dedicated Application Specific Integrated Circuits (ASICs).

Output from the CW transducer 41 is passed to a first pre-processor 42 within the processing unit 40. The CW transducer output is edge extracted and image

processed using known techniques. The pre-processor determines the relevant flow parameters, e.g. the flow profile, time velocity integral, heart rate etc. The flow parameters may be calculated over successive frames, i.e. heart beats, either to obtain average readings, or to determine variations in time based parameters.

5                    Simultaneously, the oximetry device 43 response is provided to a second pre-processor 44 and processed to determine an oxygen concentration value.

The respective outputs 46, 47 of the first and second pre-processors are then combined at the main processor 48 to calculate a tissue perfusion parameter, for example of the type described above. The tissue perfusion parameter may be compared  
10 with a tissue perfusion index stored in memory 49, prior to the parameter value, index values and other relevant information, e.g. whether an alarm condition exists, being displayed on the screen of the processor unit.

If necessary, either pre-processor 42, 44 or the main processor 48 may receive inputs from external devices, e.g. a heart rate monitor if heart rate is not calculated  
15 directly from the blood flow profile.

In Fig. 5 there is illustrated the steps undertaken in producing a tissue perfusion reading. At step 50, a CW Doppler transducer reading is obtained which is then signal processed 51 in a known manner to obtain the blood flow profile. The blood flow profile is further processed 52 to extract blood flow parameters such as time  
20 velocity integral, heart rate etc to be used as inputs for a tissue perfusion parameter calculation.

Simultaneously, an output is obtained 53 from an oximetry device and processed 54 to calculate a blood oxygen concentration value. At step 55, the blood flow parameters and blood oxygen concentration are mathematically combined using  
25 the formula previously discussed to calculate a tissue perfusion parameter. The calculated tissue perfusion value can be compared with an index value 56 to determine whether a patient has a particular condition.

In order to establish the index, the steps 50 - 55 may be repeated on a plurality of patients and the total set of results statistically combined, e.g. averaged for patient variables such as age, sex, weight etc.

While the embodiments described relate to combined intra cardiac or aortic flow and peripheral (digital) oximetry, it is further possible to combine any vessel flow with vascular oxygen concentration to determine a tissue perfusion parameter in a relevant are of the body. Other examples include such that femoral flow could be combined with pedal oximetry, cubital or axillary flow with digital oximetry or cartoid flow could be combined with aural lobar oximetry to evaluate cerebral flow. Such devices have multiple diagnostic applications in safe and cost effective delivery of health care to humans and animals, particularly in the emergency room, operating theatre, paediatric surgery, sleep medicine and in the management of heart failure.

Additionally, the invention as described herein can be used to improve understanding of the normal physiology and pathophysiology associated with cardiovascular function, exercise and pulmonary function.

The foregoing describes embodiments of the present invention and modifications, obvious to those skilled in the art can be made thereto, without departing from the scope of the present invention.

**Claims**

1. An apparatus for measuring physiologic tissue perfusion information including:
  - a first device producing a first output indicative of blood flow of a patient;
  - 5 a second device producing a second output indicative of oxygen content of the blood; and
  - a processor combining said first and said second outputs to produce a third output indicative of tissue perfusion.
- 10 2. An apparatus according to claim 1 wherein said first device uses a CW Doppler method to measure blood flow.
3. An apparatus according to claim 1 wherein said second device uses oximetry to measure oxygen content.
- 15 4. An apparatus according to claim 1 wherein said third output is indicative of at least one of percent distance stroke saturation, percent minute distance saturation output, percent stroke volume saturation stroke volume and percent output saturation output.
5. An apparatus according to claim 1 wherein said apparatus combines intra cardiac or aortic blood flow with peripheral oximetry.
- 20 6. A method of measuring physiologic tissue perfusion information including obtaining a measurement of blood flow of a patient and a measurement of blood oxygen content, and combining said measurements to produce an output indicative of tissue perfusion.
7. A method of creating a tissue perfusion index including:
  - (a) obtaining a measurement of blood flow and a measurement of blood  
25 oxygen content from a patient;

- (b) combining said measurements to calculate a parameter indicative of tissue perfusion in said patient;
- (c) repeating steps (a) and (b) on a plurality of patients to obtain a set of calculations of said parameter for said plurality of patients;
- 5 (d) processing the set of calculated parameters to obtain a statistically averaged index of said parameter for a population.
8. A method of creating a tissue perfusion index for healthy population including:
- (a) obtaining a measurement of blood flow and a measurement of blood  
10 oxygen content from a healthy patient;
- (b) combining said measurements to calculate a parameter indicative of tissue perfusion in said healthy patient;
- (c) repeating steps (a) and (b) on a plurality of healthy patients to obtain a set of calculations of said parameter for said plurality of patients;
- 15 (d) processing the set of calculated parameters to obtain a statistically averaged index of said parameter for a healthy population.
9. A method of creating a tissue perfusion index for a population with a known condition including:
- (a) obtaining a measurement of blood flow and a measurement of blood  
20 oxygen content from a patient with said known condition;
- (b) combining said measurements to calculate a parameter indicative of tissue perfusion in said patient;
- (c) repeating steps (a) and (b) on a plurality of patients with said known condition to obtain a set of calculations of said parameter for said plurality of patients;

- 12 -

(d) processing the set of calculated parameters to obtain a statistically averaged index of said parameter for a population with said known condition.

10. A method of diagnosing a condition in a patient including:

5 (a) obtaining a measurement of blood flow and a measurement of blood oxygen content from a patient;

(b) combining said measurements to calculate a parameter indicative of tissue perfusion in said patient;

10 (c) comparing said calculated parameter with a statistically averaged index of said parameter to determine the extent to which said condition exists within said patient.

11. A method according to any one of claims 7 to 10 wherein said parameter indicative of tissue perfusion is at least one of percent distance stroke saturation, percent minute distance saturation output, percent stroke volume saturation stroke volume and percent output saturation output.

15 12. A method according to any one of claims 7 to 11 wherein said measurement of blood flow comprises a transcutaneous measure of the volume of blood flow out of a patient's heart.

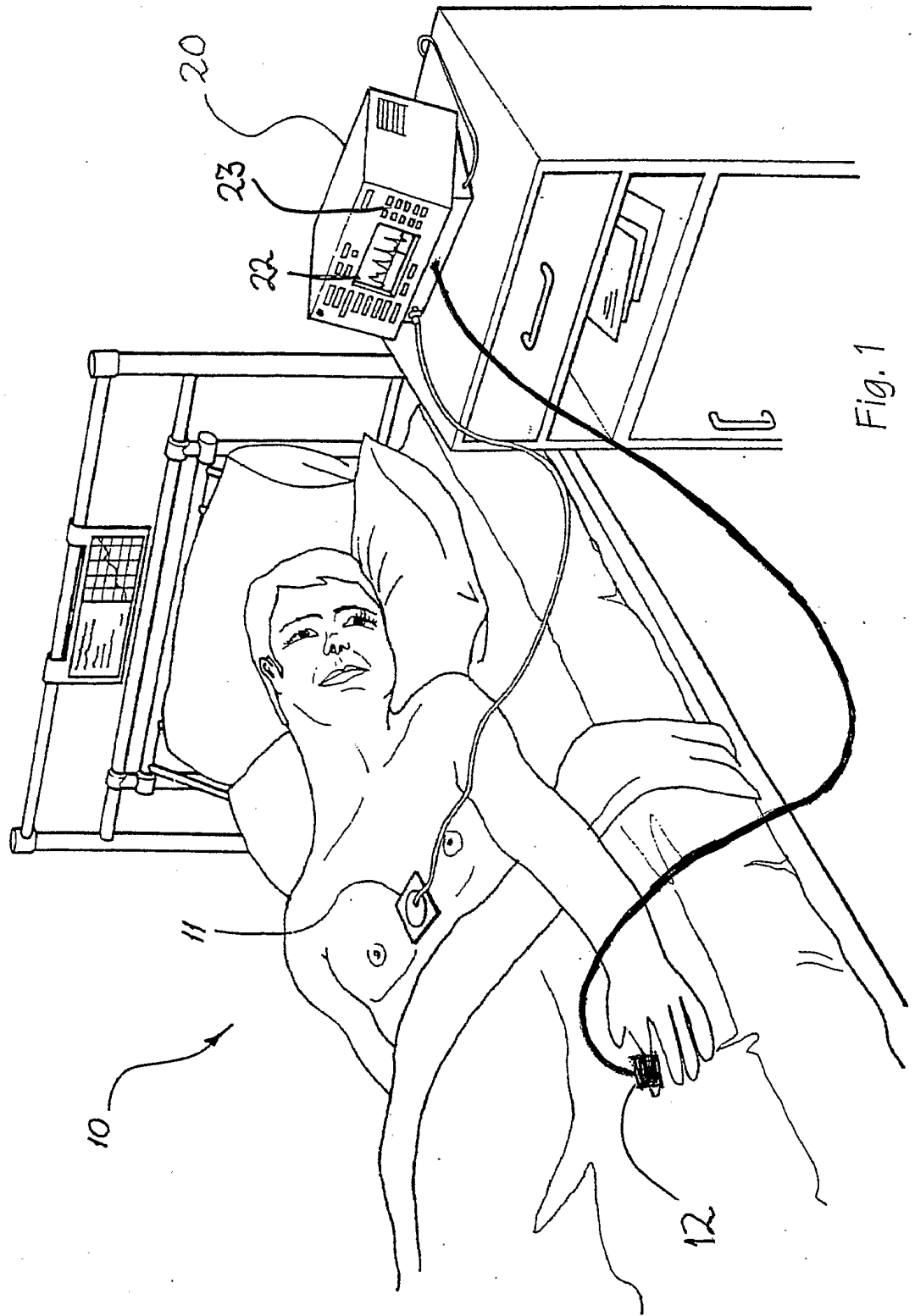

Fig. 1

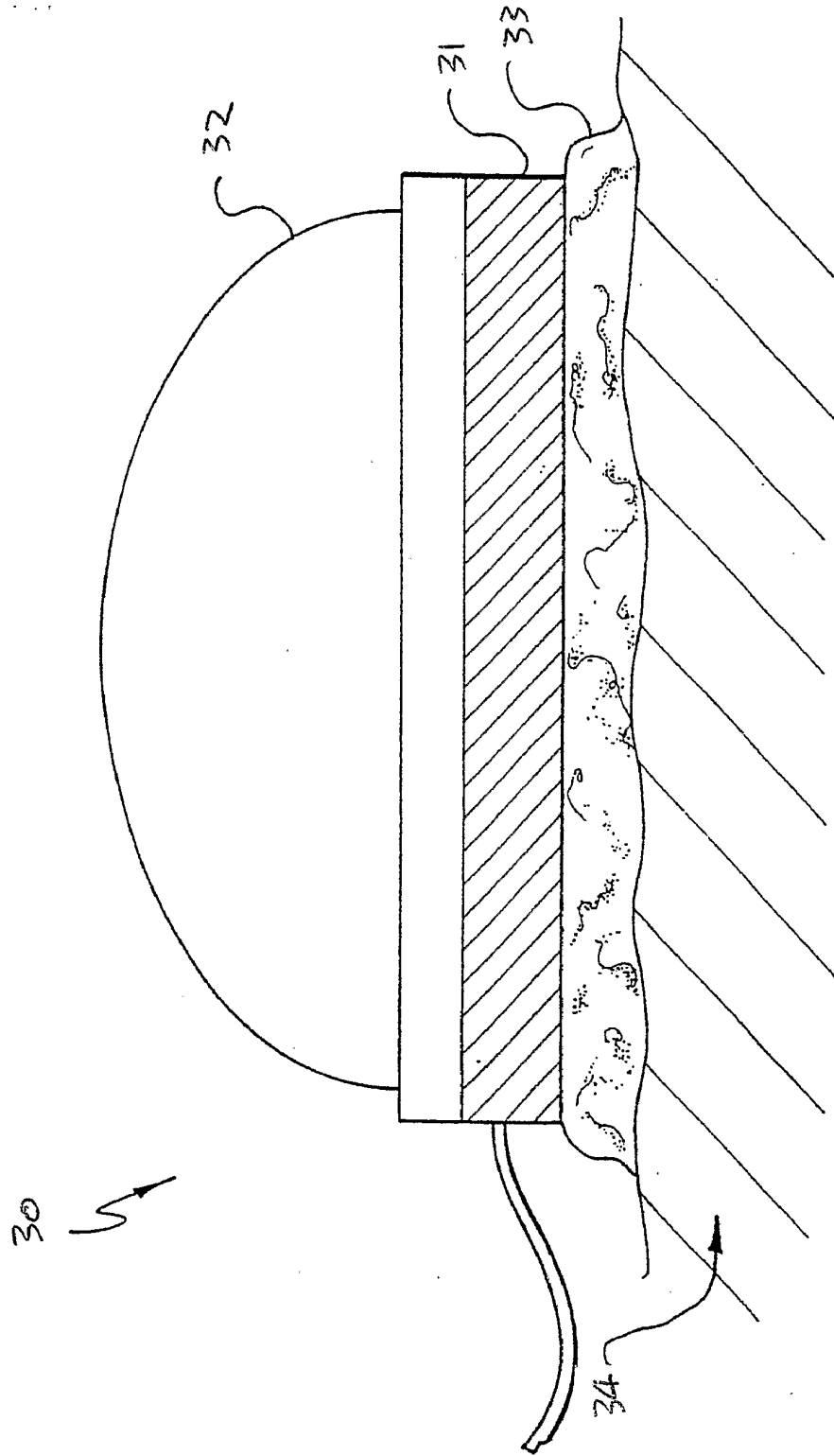

Fig. 2

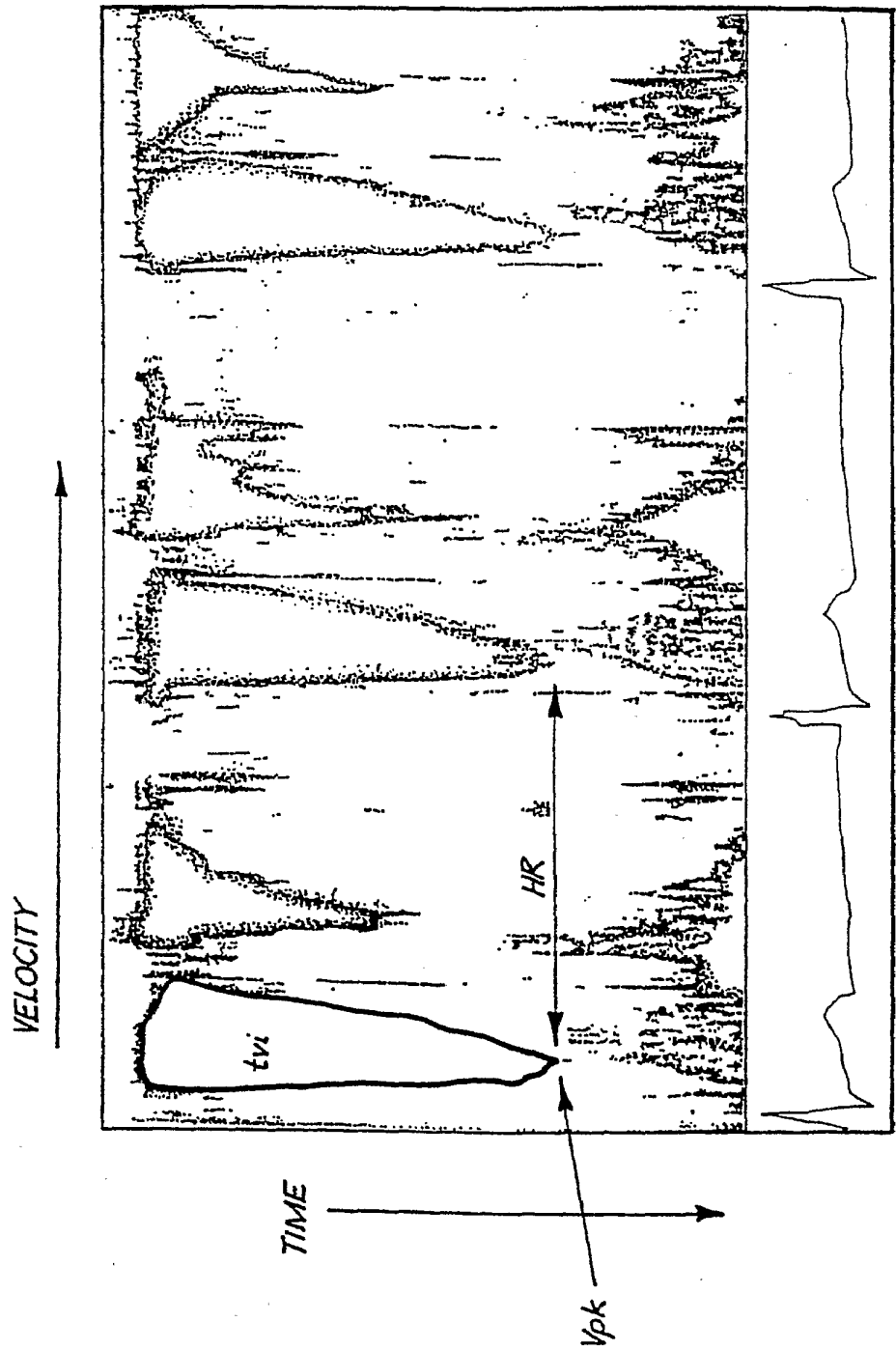

Fig. 3

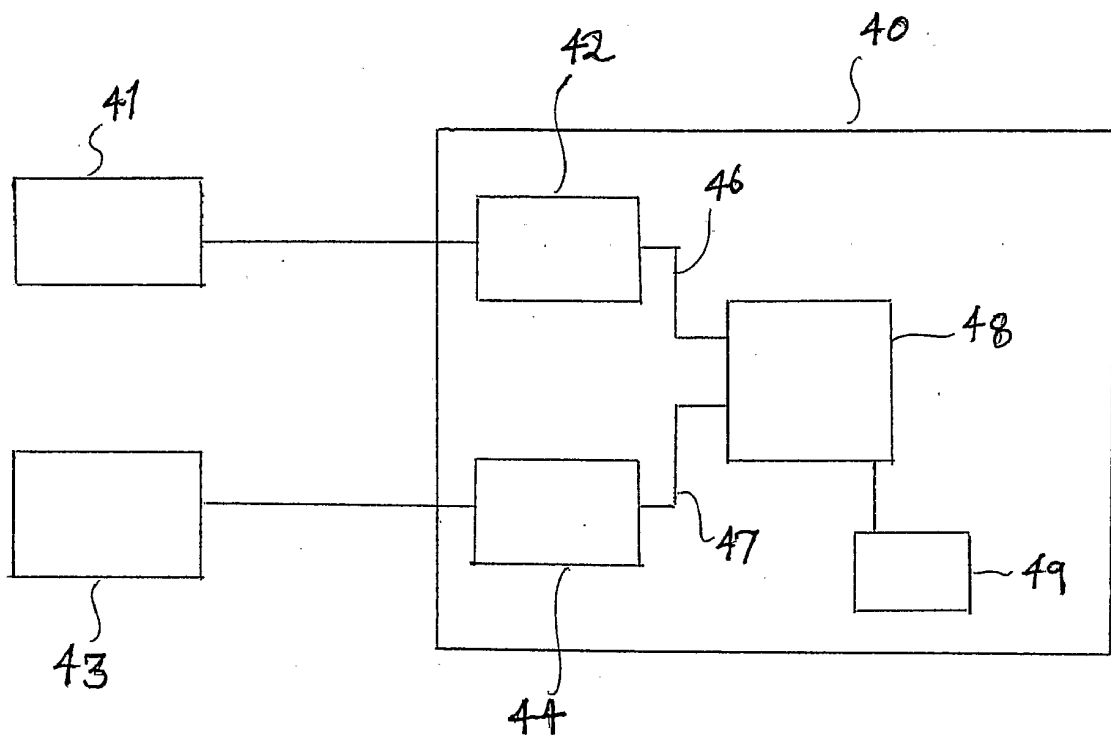

Fig. 4

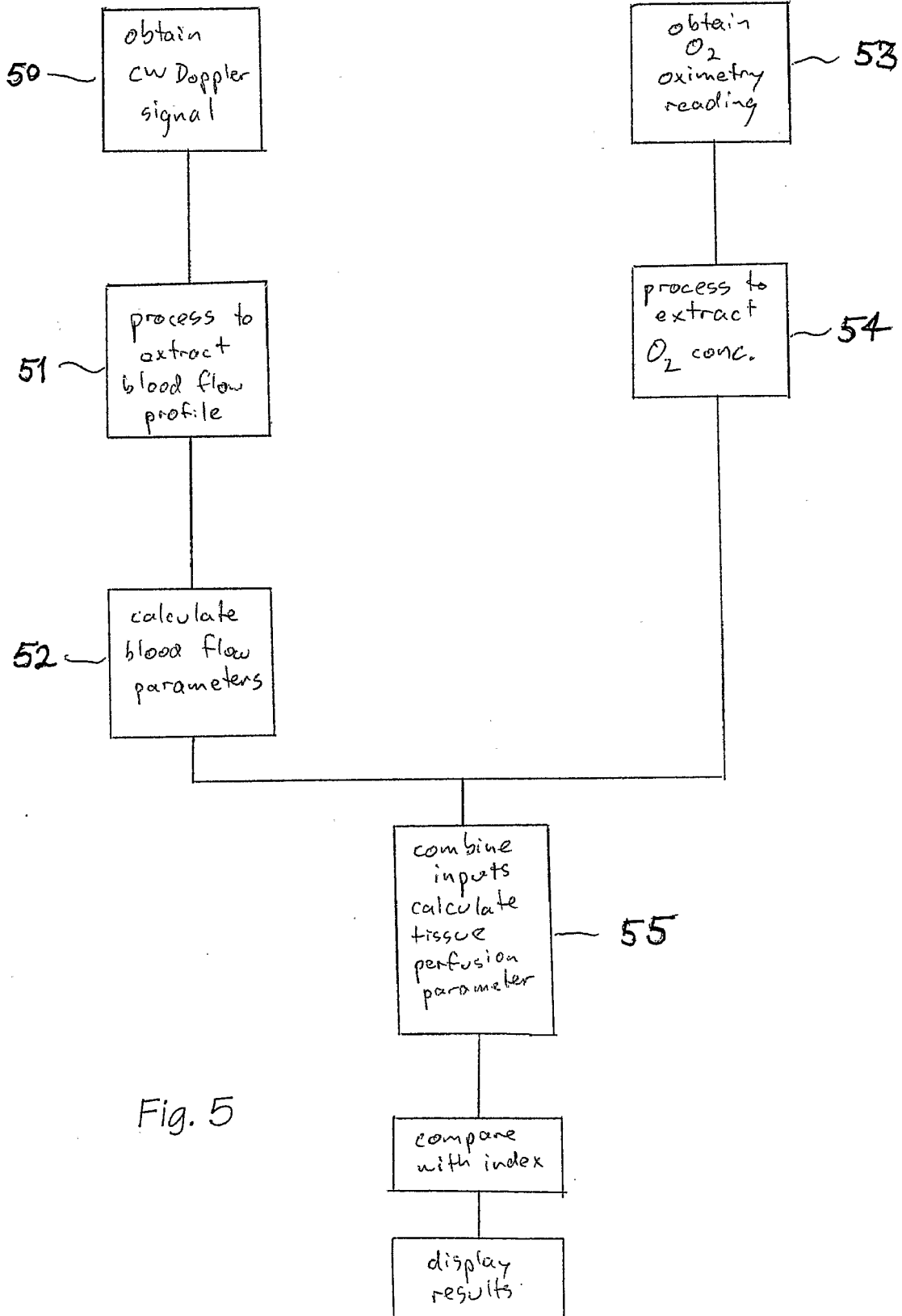

Fig. 5

## INTERNATIONAL SEARCH REPORT

International application No.

PCT/AU03/00526

<b>A. CLASSIFICATION OF SUBJECT MATTER</b>		
Int. Cl. <sup>7</sup> : A61B 5/02		
According to International Patent Classification (IPC) or to both national classification and IPC		
<b>B. FIELDS SEARCHED</b>		
Minimum documentation searched (classification system followed by classification symbols) <b>REFER TO THE ELECTRONIC DATABASE CONSULTED BELOW</b>		
Documentation searched other than minimum documentation to the extent that such documents are included in the fields searched		
Electronic data base consulted during the international search (name of data base and, where practicable, search terms used) DWPI + key words (tissue, perfusion, blood, flow, oxygen, content etc)		
<b>C. DOCUMENTS CONSIDERED TO BE RELEVANT</b>		
Category*	Citation of document, with indication, where appropriate, of the relevant passages	Relevant to claim No.
A	US 4867165 A (NOLLER et al) 19 September 1989 See entire document	1-12
A	US 3980075 A (HEULE) 14 September 1976 See entire document	1-12
A	US 5389217 A (SINGER) 14 February 1995 See entire document	1-12
<input checked="" type="checkbox"/> Further documents are listed in the continuation of Box C <input checked="" type="checkbox"/> See patent family annex		
* Special categories of cited documents:		
"A" document defining the general state of the art which is not considered to be of particular relevance	"T" later document published after the international filing date or priority date and not in conflict with the application but cited to understand the principle or theory underlying the invention	
"E" earlier application or patent but published on or after the international filing date	"X" document of particular relevance; the claimed invention cannot be considered novel or cannot be considered to involve an inventive step when the document is taken alone	
"L" document which may throw doubts on priority claim(s) or which is cited to establish the publication date of another citation or other special reason (as specified)	"Y" document of particular relevance; the claimed invention cannot be considered to involve an inventive step when the document is combined with one or more other such documents, such combination being obvious to a person skilled in the art	
"O" document referring to an oral disclosure, use, exhibition or other means	"&" document member of the same patent family	
"P" document published prior to the international filing date but later than the priority date claimed		
Date of the actual completion of the international search 24 June 2003	Date of mailing of the international search report 30 JUN 2003	
Name and mailing address of the ISA/AU AUSTRALIAN PATENT OFFICE PO BOX 200, WODEN ACT 2606, AUSTRALIA E-mail address: pct@ipaaustralia.gov.au Facsimile No. (02) 6285 3929	Authorized officer  <b>Mr. SWAYAM CHINTAMANI</b> Telephone No : (02) 6283 2202	

## INTERNATIONAL SEARCH REPORT

International application No.

PCT/AU03/00526

C (Continuation). DOCUMENTS CONSIDERED TO BE RELEVANT		
Category*	Citation of document, with indication, where appropriate, of the relevant passages	Relevant to claim No.
A	US 6315730 B1 (HOFF et al) 13 November 2001 See entire document	1-12
A	GB 1461345 A (ESCHWEILER, L & CO) 13 January 1977 See entire document	1-12

# INTERNATIONAL SEARCH REPORT

Information on patent family members

International application No.

**PCT/AU03/00526**

This Annex lists the known "A" publication level patent family members relating to the patent documents cited in the above-mentioned international search report. The Australian Patent Office is in no way liable for these particulars which are merely given for the purpose of information.

Patent Document Cited in Search Report		Patent Family Member			
US	4867165	EP	293504		
US	3980075	AR	200173	DE	2405348
		JP	49111485	SE	7401628
US	5389217	AU	18599/95	CA	2188576
		WO	9529629	EP	758210
US	6315730	AU	72190/98	EP	977594
		WO	9847533	NO	995148
GB	1461345	NONE			
END OF ANNEX					

专利名称(译)	血流氧测量系统和方法		
公开(公告)号	<a href="#">EP1503663A4</a>	公开(公告)日	2009-05-20
申请号	EP2003747376	申请日	2003-05-05
[标]申请(专利权)人(译)	USCOM		
申请(专利权)人(译)	USCOM PTY LTD.		
当前申请(专利权)人(译)	USCOM PTY LTD.		
[标]发明人	PHILLIPS ROBERT ALLAN		
发明人	PHILLIPS, ROBERT, ALLAN		
IPC分类号	A61B5/0205 A61B5/00 A61B5/0285 A61B5/145 A61B5/1455 A61B8/06 A61B5/02		
CPC分类号	A61B5/1455 A61B8/06 A61B8/4281		
优先权	2002PS2145 2002-05-06 AU		
其他公开文献	EP1503663A1		
外部链接	<a href="#">Espacenet</a>		

摘要(译)

一种用于测量生理组织灌注信息的设备，包括：第一设备，其产生指示患者的血流的第一输出；第二装置产生指示血液中氧含量的第二输出；处理器组合所述第一和第二输出以产生指示组织灌注的第三输出。

