

(19) World Intellectual Property Organization
International Bureau



(43) International Publication Date
21 February 2002 (21.02.2002)

PCT

(10) International Publication Number
WO 02/13691 A1

- (51) International Patent Classification⁷: A61B 5/05, A61M 1/16
- (21) International Application Number: PCT/US01/25309
- (22) International Filing Date: 13 August 2001 (13.08.2001)
- (25) Filing Language: English
- (26) Publication Language: English
- (30) Priority Data: 09/638,657 14 August 2000 (14.08.2000) US
- (71) Applicant: RENAL RESEARCH INSTITUTE, LLC [US/US]; 207 East 94th Street, Suite 303, New York, NY 10128 (US).
- (72) Inventors: ZHU, Fansan; 43-73 Union Street, Apartment #4D, Flushing, NY 11355 (US). LEVIN, Nathan; 200 East 89th Street, Apt. 17B, New York, NY 10128 (US).
- (74) Agents: MAYER, Richard, L. et al.; Kenyon & Kenyon, 1 Broadway, Washington, NY 10004 (US).
- (81) Designated States (national): AE, AG, AL, AM, AT, AU, AZ, BA, BB, BG, BR, BY, BZ, CA, CH, CN, CO, CR, CU, CZ, DE, DK, DM, DZ, EC, EE, ES, FI, GB, GD, GE, GH, GM, HR, HU, ID, IL, IN, IS, JP, KE, KG, KP, KR, KZ, LC, LK, LR, LS, LT, LU, LV, MA, MD, MG, MK, MN, MW, MX, MZ, NO, NZ, PL, PT, RO, RU, SD, SE, SG, SI, SK, SL, TJ, TM, TR, TT, TZ, UA, UG, UZ, VN, YU, ZA, ZW.
- (84) Designated States (regional): ARIPO patent (GH, GM, KE, LS, MW, MZ, SD, SL, SZ, TZ, UG, ZW), Eurasian patent (AM, AZ, BY, KG, KZ, MD, RU, TJ, TM), European patent (AT, BE, CH, CY, DE, DK, ES, FI, FR, GB, GR, IE, IT, LU, MC, NL, PT, SE, TR), OAPI patent (BF, BJ, CF, CG, CI, CM, GA, GN, GQ, GW, ML, MR, NE, SN, TD, TG).
- Published:**
 — with international search report
 — before the expiration of the time limit for amending the claims and to be republished in the event of receipt of amendments
- For two-letter codes and other abbreviations, refer to the "Guidance Notes on Codes and Abbreviations" appearing at the beginning of each regular issue of the PCT Gazette.*

(54) Title: DEVICE AND METHOD FOR SEGMENTAL BIOIMPEDANCE MEASUREMENTS OF A DIALYSIS PATIENT

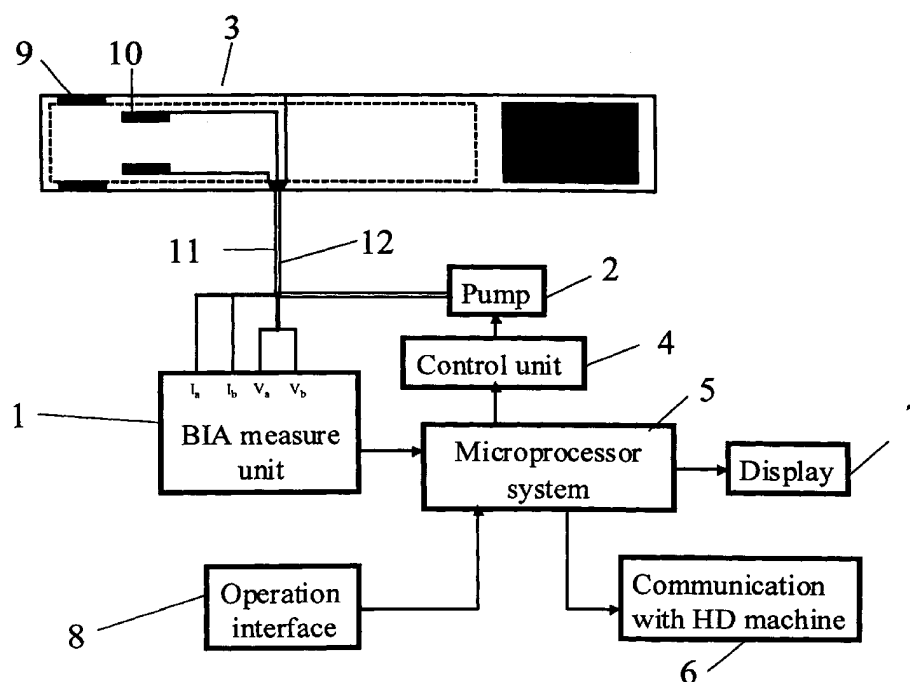

(57) Abstract: The present invention includes a method of determining the dry body weight of a patient undergoing dialysis by means of segmental bioimpedance analysis. In preferred embodiments, dry body weight is determined by comparison to the bioimpedance values of normal subjects or by monitoring changes in bioimpedance during dialysis. One embodiment of the present invention is a device for determining dry body weight during dialysis.

WO 02/13691 A1

DEVICE AND METHOD FOR SEGMENTAL BIOIMPEDANCE MEASUREMENTS OF A DIALYSIS PATIENT

5

Field of the Invention

The present invention relates to a device and method that utilize segmental bioimpedance for monitoring and controlling physiologic parameters of a dialysis patient.

10

Background of the Invention

Accurate assessment of a dialysis patient's hydration status and prediction of dry body weight (DW or dry weight) is a major problem in the clinical management of the dialysis patient. In both hemodialysis and peritoneal dialysis patients, dry weight is the target weight at the end of dialysis treatment which best reflects removal of excess water from the body. In clinical practice, estimation of DW is an imprecise undertaking, and depends to a large extent on the treating physician's interpretation, based on his or her medical experience and familiarity with the particular patient's condition, of clinical symptoms and signs such as changes in the blood pressure, pulse, and weight of the patient. The correct interpretation of such signs and symptoms is complicated by the fact that the pre-treatment body weight varies for each treatment, the amount of excess fluid is not constant and the amount of fluid that can or should be removed from any particular patient during any particular dialysis treatment may be limited by an individual's cardiovascular tolerance, often manifested by clinical signs and symptoms, such as pretibial edema, dyspnea, cramps and/or a decline in blood pressure. Alternatively, an overestimation of the amount of fluid to be removed may result in potentially avoidable

25

symptoms, unnecessarily lengthy dialysis treatments and often prolonged stays at the dialysis facility. Therefore, over- or underestimation of DW will significantly affect both the efficiency of dialysis treatment and patients' quality of life.

Bioelectrical impedance analysis (BIA) has been recognized as a noninvasive and simple technique to measure body hydration and hydration status (i.e. over-, under- or normal hydration) of subjects for more than twenty years. There is substantial literature on using BIA for the study of dry weight. Kouw *et al* proposed a method to measure changes in regional conductivity, and then to measure regional extracellular volume (ECV) and intracellular volume (ICV) by BIA. *See*, P.M. Kouw, et al, *Assessment of post-dialysis dry weight: an application of the conductivity measurement method*. *Kidney Int.* 41:440-444,1992. However, Kouw's method cannot be used to measure interstitial fluid alone as it does not distinguish between interstitial fluid and plasma, both of which make up the ECV compartment. Piccoli published a method of BIA vector analysis which uses the ratio of resistance to reactance to identify dry weight. While this technique could be used to compare the subjects' body hydration, it is unable to predict individual patient's dry weight because of the significant variation in measured values. *See*, Piccoli A: *Identification of operational clues to dry weight prescription in hemodialysis using bioimpedance vector analysis.* *Kidney Int.* 53:1036-1043,1998

Recently, there have been increased numbers of dry weight studies using blood volume (BV) measurements. *See, for example*, J.P. de Vries *et al*, *Non-invasive monitoring of blood volume during hemodialysis: Its relation with post-dialytic dry weight*. *Kidney Int* 44:851-854,1993, and J.K. Leypold, *et al*, *Determination of circulating blood volume by continuously monitoring hematocrit during hemodialysis*. *J. Am. Soc. Nephrol.* 6:214-219,1995. Blood volume measurement is a noninvasive

technique that can be used to indicate water concentration in blood, i.e. hematocrit, during hemodialysis, but it cannot be used to directly determine dry weight because changes in blood volume are mainly dependent on the rate of vascular refilling which, in part, is independent of body hydration. See, e.g., J.K. Leypoldt, *et al*, *Evaluating volume status in hemodialysis patients*. Adv. Ren. Replace. Ther. 5:64-74,1998. On the other hand, since a change in the hematocrit level may alter conductivity in the blood during dialysis, it is difficult to obtain information about tissue hydration by either traditional bioelectrical impedance analysis or blood volume analysis. To date, a major problem has been how to measure resistivity of blood and tissue separately, in order to estimate the fluid volume in the intravascular compartment and the interstitial compartment, respectively.

Thus, there is a need for a precise, easily used and operator independent method for determining the hydration status of a dialysis patient, identifying or predicting the dry weight of such a patient and calculating the amount of fluid that should be removed during a dialysis session. In addition, there is a need for a method of controlling dialysis in response to a patient's hydration status.

Summary of the Invention

The present invention includes a method for determining the hydration status of a dialysis patient comprising the steps of measuring the resistivity of a body segment of the patient, correlating the measured resistivity with predetermined normal dry weight values, and deriving the patient's hydration status. Optionally the resistivity of the interstitial fluid in the body segment is measured to derive the patient's hydration status. In one embodiment, the resistivity of the body segment is determined while applying a pressure of at least about systolic blood pressure, optionally from about 120 mmHg to

about 240 mmHg. The body segment can be a limb segment, preferably a thigh segment.

Included, is a method for determining a hemodialysis patient's dry weight comprising the steps of periodically measuring the resistivity of a body segment during hemodialysis; comparing successive resistivity measurements; and identifying the patient's dry weight when a substantially constant resistivity is reached. Optionally, resistivity is measured from about every 5 minutes to about every 20 minutes during hemodialysis, preferably about every 10 minutes during hemodialysis. In one embodiment the resistivity of the body segment is measured at a pressure of at least about systolic blood pressure, optionally from about 120 mmHg to about 240 mmHg.

The present invention includes a method for dialysing a patient to the patient's dry weight that comprises measuring the resistivity of a body segment of the patient, correlating the measured resistivity with predetermined normal dry weight values, deriving the patient's hydration, and continuing hemodialysis until the resistivity of the body segment correlates with the predetermined normal dry weight values, preferably measuring the resistivity of the body segment at a pressure of at least about systolic blood pressure.

Also provided is a method for hemodialysing a patient to the patient's dry weight comprising the steps of periodically measuring the resistivity of a body segment during hemodialysis, comparing successive resistivity measurements, and discontinuing hemodialysis when a substantially constant resistivity is reflected. Preferably, the resistivity of the body segment is measured at a pressure of at least about systolic blood pressure. In this embodiment, the resistivity of the body segment is measured from about every 5 minutes to about every 20 minutes during hemodialysis.

The present invention also provides a method of monitoring the heart rate of a

hemodialysis patient comprising the steps of determining a time interval between two successive bioimpedance wave peaks and multiplying the reciprocal of the time interval by 60 to obtain the heart rate, and a method of calculating the cardiac output of a patient in need thereof comprising the steps of measuring the stroke volume in an arm segment by
5 bioimpedance analysis, substantially simultaneously measuring the stroke volume in an ipsilateral leg segment by bioimpedance analysis, summing the stroke volume in the arm segment and the stroke volume in the leg segment, and multiplying the sum by twice the heart rate to obtain the cardiac output. Preferably, the stroke volume of the arm segment is calculated by applying an external maximum pressure to the arm segment and
10 determining the change in blood volume in the arm segment between the point of maximum pressure and the point at which no external pressure is applied divided by the number of heart beats between the two points in time, and the stroke volume of the leg is calculated by applying an external maximum pressure to the leg segment and determining the change in blood volume in the leg segment between the point of maximum pressure
15 and the point at which no external pressure is applied divided by the number of heart beats between two points in time.

Included is a device for controlling a hemodialysis machine comprising a bioimpedance analysis measurement unit in electrical communication with a hemodialysis machine, an electrical output means that is in electrical communication
20 with the bioimpedance analysis measurement unit and that is attachable to a body segment, the electrical output means is adapted to apply electrical current to the body segment, an electrical input means that is in electrical communication with the bioimpedance analysis measurement unit and is attachable to a body segment, the electrical input means being adapted to receive the current transmitted through the body
25 segment and transmit the same to the bioimpedance analysis measurement unit. The

bioimpedance analysis measurement unit is adapted to determine body segment resistivity based on the current transmitted through the body segment and the bioimpedance analysis measurement unit provides feedback to the hemodialysis machine in response to the body segment resistivity. In one preferred embodiment, the device
5 includes means for applying pressure to the body segment, the pressure applying means is in electrical communication with the bioimpedance analysis measurement unit.

Optionally, the pressure applying means includes a pressure cuff that is adapted to encircle the body segment. Preferably, the electrical output means includes at least two injector electrodes, the electrical input means includes at least two measurement

10 electrodes. The injector electrodes and the measurement electrodes are secured to the pressure cuff. Optionally, the pressure cuff includes at least one conductive band with opposing ends and a conductive plate positioned adjacent one of the ends of the conductive band, the conductive band extends substantially the length of the pressure cuff. The conductive plate is arranged to electrically contact the conductive band at a
15 point along the length of the same wherein the distance between the conductive plate and the point of contact of the conductive band is substantially equal to the circumference of the body segment, and wherein the bioimpedance analysis measurement unit is adapted to electrically determine body segment circumference based on the distance between the end of the band adjacent to the plate and the point of contact of the plate along the length
20 of the band.

One embodiment is a device for monitoring hydration status in a hemodialysis patient comprising a bioimpedance analysis measurement unit, an electrical output means, optionally comprising at least two injector electrodes, being in electrical communication with the bioimpedance analysis measurement unit and being attachable to
25 a body segment, the electrical output means being adapted to apply electrical current to

the body segment, an electrical input means, optionally comprising at least two measurement electrodes, being in electrical communication with the bioimpedance analysis measurement unit and being attachable to a body segment, the electrical input means being adapted to receive the current transmitted through the body segment and transmit the same to the bioimpedance analysis measurement unit. The bioimpedance analysis measurement unit is adapted to determine body segment resistivity based on the current transmitted through the body segment. Optionally the device includes a hemodialysis machine. Optionally the device includes means for applying pressure to the body segment, optionally a pressure cuff. The pressure applying means being in electrical communication with the bioimpedance analysis measurement unit. One embodiment of the device includes a pressure cuff with at least one conductive band with opposing ends and a conductive plate positioned adjacent one of the ends of the conductive band. The conductive band extends substantially the length of the pressure cuff and is arranged to electrically contact the conductive band at a point along the length of the same wherein the distance between the conductive plate and the point of contact of the conductive band is substantially equal to the circumference of the body segment, and wherein the bioimpedance measurement unit is adapted to electrically determine body segment circumference based on the distance between the end of the band adjacent to the plate and the point of contact of the plate along the length of the band.

The present invention includes a device for calculating cardiac output through bioimpedance measurements of a patient comprising a bioimpedance measurement unit, a first electrical output means being in electrical communication with the bioimpedance analysis measurement unit and being attachable to an arm segment, the first electrical output means being adapted to apply electrical current to the arm segment, a second electrical output means being in electrical communication with the bioimpedance

analysis measurement unit and being attachable to a leg segment, the second electrical output means being adapted to apply electrical current to the leg segment, a first electrical input means being in electrical communication with the bioimpedance analysis measurement unit and being attachable to an arm segment, the electrical input means being adapted to receive the current transmitted through the arm segment and transmit the same to the bioimpedance analysis measurement unit, a second electrical input means being in electrical communication with the bioimpedance analysis measurement unit and being attachable to a leg segment, the electrical input means being adapted to receive the current transmitted through the leg segment and transmit the same to the bioimpedance analysis measurement unit, a first pressure applying means for applying a maximum pressure to the arm segment, the first pressure applying means being in electrical communication with the bioimpedance analysis measurement unit, a second pressure applying means for applying a maximum pressure to the arm segment, the second pressure applying means being in electrical communication with the bioimpedance analysis measurement unit, means for selectively electronically connecting the bioimpedance analysis measurement between the first electrical input and output means and the second electrical input and output means, and wherein the bioimpedance analysis measurement unit is adapted to selectively measure stroke volume in the arm and leg segments by bioimpedance analysis.

Other objects, features and advantages of the invention will be readily apparent from the following detailed description of a preferred embodiment thereof taken in conjunction with the drawings.

Brief Description of the Figures

Figure 1A and 1B each represent a stylized 3-dimensional view of a body

segment, that illustrates the principle of measuring resistivity according to one embodiment of the present invention. Figure 1A represents the situation in which no external pressure is applied to the segment and the blood vessels are uncompressed. Figure 1B illustrates the situation in which external pressure is applied to the segment and the blood vessels are compressed.

Figure 2 is a block diagram of a measurement system according to the present invention.

Figure 3 is a graph of relative changes in systolic blood pressure, ultrafiltration rate, resistivity of different body segments, and relative blood volume over time during hemodialysis.

Figure 4 is a graph of post-dialysis resistivity compared to dry weight in ten male hemodialysis patients.

Figure 5 is a graph showing the relationship between blood pressure and resistivity of a limb segment in ten male hemodialysis patients at the end of hemodialysis.

Figure 6 is a graph of Body Mass Index versus resistivity in a limb segment in ten male healthy subjects.

Figure 7 is a graph showing the change in body segment impedance in relation to the change in body segment blood volume due to arterial pulses.

Figure 8 is a graph showing changes in impedance of a limb segment in relationship to pressure cuff pressure.

Figure 9 is a bar graph showing the correlation between a series of ten male hemodialysis patients' post dialysis limb segment resistivity, with and without correction for dry weight, and the limb segment resistivity in a series of ten healthy male subjects.

Figure 10 is a diagram of a pressure cuff for measurement of the circumference of a body segment and for use in measurement of segmental bioimpedance when the body

segment is compressed or uncompressed. Shown is a front view with the covering partially cut away, and in Figure 10A, a partial back view showing the conductive plates.

Figure 11 is a block diagram of a device according to the present invention that also provides a means for determining cardiac output.

Detailed Description of the Invention

The present invention provides a method of determining hemodialysis and peritoneal dialysis patients' hydration status, or more specifically, dry weight, to facilitate the appropriate dialysis prescription. The invention comprises a means of determining and monitoring the resistivity of the patient's body or body segment, and hence the correct dry weight or desired hydration status of a patient undergoing dialysis. The invention further provides a method for determining and monitoring various physiologic parameters of the patient undergoing dialysis, including but not limited to heart rate (HR) and cardiac output (CO).

From a physiological point of view, in healthy people the amount of fluid in the interstitial compartment should be a relatively constant value within a small range. Thus, this value should be the criterion to indicate the degree of a patient's body hydration.

We have found that the refilling volume of a peripheral body segment, such as an arm (upper extremity) or leg (lower extremity), is an important indicator of a dialysis patient's hydration status or dry body weight. In one aspect, the present invention provides a means to separately measure, by segmental bioimpedance analysis (SBIA), the degree of regional body hydration, including fluid volume in the interstitial compartment and the intravascular compartment, in order to determine a patient's fluid status and dry body weight.

One preferred embodiment of the present invention comprises a means to measure the resistivity of a body segment. The body segment may be the whole body, preferably a limb segment, more preferably a leg or arm segment, and most preferably a thigh segment. As shown in Figure 1A, the resistivity of a body segment is measured by the placement of measurement electrodes at points L1 and L2, separated by a distance L. One of skill in the art will appreciate that while distance L may vary, it is preferably about 10 cm. The resistivity between L1 and L2 is denoted as R. Also shown in Figure 1A is a cross-section of the body segment with the interstitial compartment denoted as T and blood vessels denoted as B. Optionally, a means to compress the body segment is provided, for example a pressure cuff 3 that surrounds the body segment. When the body segment is not compressed, for example when the pressure cuff 3 is uninflated, the blood vessels are uncompressed and the resistivity R reflects the resistivity of both the interstitial compartment T and the intravascular compartment B. As shown in Figure 1B, when the body segment is compressed, for example by inflating the pressure cuff, to a pressure above about the systolic blood pressure, optionally up to about 240 mmHg, the blood vessels are compressed and substantially all of the blood volume contained within the intravascular compartment of the body segment is forced out of the body segment. When the resistivity between the electrodes placed at L1 and L2 is measured under such circumstances, the resistivity value ρ_i represents the resistivity of the interstitial compartment of the body segment.

The principle of measurement of segmental bioimpedance provides a means to measure segmental resistivity and may be explained with reference to Figures 1A and 1B. Segmental resistivity is calculated using the formula:

$$\rho_{\text{measure}} = A\rho_i/L \text{ (m}\cdot\Omega\text{)}$$

Where ρ_{measure} is the measured segmental resistivity; A is the cross-sectional area

of the segment ($A = C^2/4\pi$, where C is the circumference of the segment) When no pressure is applied to the body segment the cross sectional area A_0 represents the cross sectional area of the body segment including that of the blood vessels, when pressure of at least systolic blood pressure is applied the cross sectional area A_p is that of the body segment minus the cross sectional area of the blood vessels ; ρ is resistivity as measured by bioimpedance analysis; and L is the distance between the measurement points (i.e. the distance between measurement electrodes).

The measured resistivity of the body segment depends on a number of factors including the frequency of the injected current and the body mass index (BMI).

Preferably a single frequency, optionally multiple frequencies (multi-frequencies) are used. Injected frequencies from about 1 kHz to about 1000 kHz, more preferably from about 1 kHz to about 50 kHz, most preferably from about 1 kHz to about 10 kHz are utilized. BMI reflects fat content, and is defined as the body weight in kg divided by the square of the height in meters ($\text{weight}/\text{height}^2$) and is typically measured in kg/m^2 . In order to distinguish between intravascular and interstitial fluid, preferably the body segment is compressed, optionally by a pressure cuff, preferably a blood pressure cuff (BP cuff) to produce a pressure (P) sufficient to squeeze blood volume out of the studied segment over a few seconds. Thus, two resistivity values can be measured: ρ_0 (uncompressed body segment, $P = 0$ mmHg) and ρ_p (body segment is compressed to a pressure from about systolic blood pressure up to $P_{\text{max}} = 240$ mmHg).

Based on the resistivity measurement, dry weight and the excess body fluid is calculated according to the equation:

$$\text{Dry weight} = \text{pre-weight} - V_{\text{excess}}$$

Where pre-weight is the weight of the patient at a time prior to the completion of dialysis, preferably prior to the initiation of dialysis, and V_{excess} is the excess volume of

fluid in a patient's body that must be removed in order to achieve dry weight.

The equation to calculate V_{excess} is:

$$V_{\text{excess}} = (k_1/k_2) \cdot \rho_{\text{cal}} \cdot \text{BMI}_p \quad (\text{Equation 1})$$

Where BMI_p is the body mass index (kg/m^2) of the dialysis patient,

5 ρ_{cal} is resistivity ($\text{m} \times \Omega$) which is obtained by the equation as follows:

$$\rho_{\text{cal}} = \lambda \cdot \text{BMI}_p + 200, \quad (\text{m} \times \Omega); \quad \text{Eq.1.1}$$

Where λ is the fitting coefficient of resistance/ density ($\Omega/(\text{kg}/\text{m}^3)$) derived from a linear regression equation based on the relationship between BMI and resistivity in healthy subjects; and

10 where BMI_p is the BMI of the patient.

It is anticipated that specific coefficients will be derived for specific populations for improved results. By way of example, which is not intended to be limiting, utilizing experimental data shown in Figure 6 from the ten healthy male subjects set forth in Example 1 (below), $\lambda = 13 \text{ } (\Omega/(\text{kg}/\text{m}^3))$. The value of 200 ($\text{m} \cdot \Omega$) is the baseline of resistivity when BMI has a minimum value (that must be larger than zero)

15 k_1/ k_2 (m/ohm) is a coefficient constant depending on the measurement value according to body geometry and tissue resistivity of the individual patient; and

$$\text{where } k_1 = C_1 \times C_2$$

and where C_1 is obtained by means of a linear regression equation derived from suitable experimental data correlating the relationship between resistivity of a body segment and clinical dry weight values in dialysis patients; and

$$C_2 = \rho_{\text{cal}} / (\rho_{\text{cal}} - \rho_{\text{measure}})$$

where ρ_{measure} is the resistivity in a body segment of a dialysis patient measured by SBIA while the body segment is compressed to a pressure of at least about systolic

pressure;

Again, it is anticipated that specific coefficients will be derived for specific populations for improved results, but by way of example, which is not intended to be limiting, utilizing experimental data shown in Figure 4 and derived from the ten male hemodialysis patients described in Example 1, $C_1 = 2.2 \times 10^{-1} \text{ kg}/(\text{m} \cdot \Omega)$ and $C_2 = 3.5$

K_2 is the average value for BMI in a population of healthy subjects. In a sample of ten healthy males described in Example 1, the average BMI, K_2 is approximately 26.8 kg/m^2 , and ρ_{cal} is the calculated resistivity ($\text{m} \cdot \Omega$) = $(13 \times \text{BMI}_p) + 200$ ($\Omega \cdot \text{m}^3/\text{kg}$)

The measurement system comprises a high speed, low noise, acquisition and multi-frequency bioimpedance measurement unit, such as is known to one of ordinary skill in the art, preferably a Xitron 4200s (Xitron Technologies, San Diego, CA).

Connected to the bioimpedance measurement unit, the system includes an electrical output means attachable to a body segment, the electrical output means preferably comprising at least two injector electrodes for application to a body segment and for the injection of current into the body segment. The system can apply a single frequency of current, or optionally multiple frequencies of electricity (multi-frequencies) ranging from about 1 kHz to about 1000 kHz, more preferably from about 1 kHz to about 50 kHz, most preferably a single frequency from about 1 kHz to about 10 kHz through the injector electrodes. The system further comprises an electrical input means that is adapted to receive the electrical current transmitted from the output means and through the body segment and to then transmit the current to the bioimpedance analysis measurement unit.

The input means comprises at least two measurement electrodes for application to the body segment for the receiving and transmission, to the BIA measurement unit, of current transmitted through the selected segment. The electrodes may be made of Ag/AgCl film, conductive rubber, or other appropriate materials which are readily apparent to one of

ordinary skill in the art. The injector and measurement electrodes are connected electrically to the BIA measurement unit. This electrical connection may be accomplished by a number of means readily apparent to a person of ordinary skill in the art, but preferably by electrical cables.

5 In one preferred embodiment of the present invention, the electrodes are incorporated into a pressure cuff suitable for surrounding and compressing the body segment. A single cable optionally may incorporate both the electrical wires to the injector and measurement electrodes and the air tubing connected to the pressure cuff. Such a cable is used to connect the pressure cuff to the measuring unit and an optional air
10 pump. Alternatively, separate electrical cables and a separate air hose may be employed. Optionally, the pressure cuff incorporates a means for electrically measuring the circumference of the body segment. An example of a preferred pressure cuff configuration 3, which is not intended to be limiting in any way is disclosed in Figure 10. The pressure cuff 3 is a blood-pressure cuff type device that comprises a substantially
15 rectangular form suitable for wrapping around a body segment, such that the body segment is encircled by the device. The pressure cuff is composed of a fabric or other flexible material that preferably is capable of being easily cleaned and/or decontaminated. Material that is suitable will be readily apparent to one of ordinary skill in the art. The pressure cuff also includes a means for securing the device on the
20 body segment, such as a Velcro® system or other such securing system 26, as will be readily apparent to one of ordinary skill in the art. Contained within the pressure cuff 3 is a flexible air-bladder 25 or similar means of compressing the body segment, and applying substantially circumferential pressure of at least about systolic blood pressure to the body segment. The air-bladder is connected to an air hose through which air can be
25 moved to inflate or deflate the air-bladder. The pressure cuff preferably includes at least

two injector electrodes 9 and at least two measurement electrodes 10 incorporated therein. The injector and measurement electrodes are electrically connected, preferably by electrical wires 20 and 21 respectively, to a cable connector 27, or other means of electrically connecting the pressure cuff 3 to a bioimpedance measurement unit. At least one, preferably two conductive bands 24 extend substantially the length of the pressure cuff, such that the length of the bands is at least equal to the smallest normal body segment circumference. The bands are composed of a material of stable resistivity. Suitable material includes Cu-Sc alloy or conductive rubber. Other suitable material will be readily apparent to one of ordinary skill in the art. The pressure cuff also comprises at least one and preferably two conductive plates 28 located at the end of the pressure cuff opposite to the end with the securing means 26. The conductive bands 24 and conductive plates 28 are electrically isolated from one another and each is connected, preferably by wires 22 and 23, respectively, to a means of measuring resistivity. The band(s) 24 and plate(s) 28 are arranged on the pressure cuff, such that when the pressure cuff is wrapped around the body segment, the plate(s) 28 electrically connects with the band(s) 24 at a location or locations along the length of the belt such that the distance, measured along the length of the pressure cuff, from the plate(s) 28 to the point of contact on the band(s) 24 is substantially equal to the circumference of the body segment. The circumference of the body segment then can be determined electrically according to the equation:

$$L_{b1} = R1 \times A1 / \rho1$$

Where L_{b1} is the length of the band between the end of the pressure cuff 3 closest to the end where the plate(s) is (are) located and the location at which the plate 28 contacts the band 24;

where $R1$ is the resistivity of the band between its end closest to the end at which the plate(s) is (are) located and the location at which the plate 28 contacts the band;

where A_1 is the cross-sectional area of the band;

and ρ_1 is the resistivity of this material.

In this manner, by determining the resistivity of the length of the band(s) that substantially equals the circumference of the body segment, the circumference of the body segment can be determined electrically. In this embodiment, it is preferred that the pressure cuff be securely applied prior to each measurement in order to more accurately measure body segment circumference.

Another embodiment comprises a device for controlling a hemodialysis machine. In this and in other embodiments disclosed herein, an example of a hemodialysis machine suitable for use in or with the invention is that disclosed in U.S. Patent No. 5,580,460 to Polaschegg. An example, which is not intended to be limiting in any way, is depicted in Figure 2. In addition to the BIA measurement unit 1, the measurement system also comprises one or more of an air pump 2 to produce pressure to inflate the pressure cuff 3, a control unit 4 to transfer signals from the microprocessor in order to operate the pump, a microprocessor system 5 which is at least a minimal computer with fast data transfer, rapid access and a memory space sufficiently large to permit the manipulation and analysis of the inputted data, a means of communicating with the dialysis machine 6 whereby control signals are sent to and received from the dialysis machine allowing the control of ultrafiltration rate and other hemodialysis parameters according to body hydration status, a display 7 that shows the result of online measurement and an operation interface 8 to input individual patients' parameters to monitor and control dry weight and optionally a means of communication to a standard personal computer (PC) or other device. Optionally, data including, but not limited to, resistance, resistivity, cuff pressure and heart rate is transmitted to the PC by a RS 232 interface or another standard interface in ASCII or other format such that the waveforms of resistivity, pressure values, heart

rates and other parameters can be observed, stored, or manipulated on the PC. The block diagram in Figure 2 shows injector electrodes 9 and measurement electrodes 10, optionally incorporated into the pressure cuff 3. The injector and measurement electrodes are attached, preferably by electrical wiring 11, to the to the output sockets I_a and I_b and 5 input (measurement) sockets V_a and V_b of the BIA measurement unit 1, and the air pump 2 is connected to the pressure cuff by an air hose 12.

In this embodiment, various patient specific parameters are input into the microprocessor system 5 by means of the operation interface 8. Inputted data and other data optionally are displayed in the display 7. The microprocessor system 5 is 10 connected to the BIA measurement unit 1 by a means of transmitting signals to the BIA measurement unit and signaling the BIA measurement unit to send electrical current to the injector electrodes 9. When such an electrical current is sent through the injector electrodes into the body segment, the current is detected by the measurement electrodes and transmitted back to the BIA measurement unit for processing, the derived date being 15 transmitted to the microprocessor system. The microprocessor system is also connected to the pump control unit 4 which is capable of sending signals to the air pump 2 to inflate and deflate the pressure cuff 3, allowing bioimpedance measurements to be made with the pressure cuff inflated and/or deflated. The microprocessor system is also connected to the hemodialysis machine by a communication means 6, whereby signals can be sent to 20 the hemodialysis machine permitting changes in the hemodialysis procedure, such that the patient's hydration status may be altered.

In one embodiment of the present invention, the ultrafiltration rate is varied by the microprocessor in response to on-line monitoring of the patient's segmental resistivity in order to achieve the patient's proper dry weight or other desired hydration status, and to 25 prevent hypotension during hemodialysis. Optionally, the individual ultrafiltration rate is

varied using a time course function related to the slope of changes in segmental resistivity (explained below) during dialysis to optimize the hemodialysis treatment.

The present invention provides a means to determine hemodialysis and peritoneal dialysis patients' dry weight to facilitate the appropriate dialysis prescription. In one preferred embodiment of the present invention segmental bioimpedance is continuously measured in a body segment during hemodialysis. The body segment may be any portion of the body or the entire body, but is preferably a limb segment, more preferably a leg or arm segment, most preferably a thigh segment. The relative changes in the value of resistivity is calculated from about every 20 minutes to about every one minute, more preferably about every 10 minutes, even more preferably about every 5 minutes, and most preferably about every minute. The circumference of a body segment, preferably a thigh segment or optionally an arm segment, is measured, preferably at the start, optionally at the end of treatment, and preferably intermittently during dialysis, more preferably from about every 10 minutes to about every 20 minutes, in order to derive the cross-sectional area of the segment. Preferably, at least two injector electrodes and at least two measurement electrodes are attached to the body segment. The electrodes may optionally be incorporated within a pressure cuff in the manner set forth above (*see, for example, Figure 10*). applied with a pressure cuff and may more preferably be applied as part of a pressure cuff-electrode combination device.

Periodically, current is injected into the body segment through injector electrodes and the current transmitted through the body segment is received by the measurement electrodes. Current from the measurement electrodes then is transmitted to the BIA measurement unit, which determines the resistance of the body segment and optionally transmits the calculated resistance to a microprocessor system that calculates the resistivity according to the method disclosed herein, and which, in turn, may control a

hemodialysis machine. Multiple resistivity data points are obtained over time, a curve is derived, and the slope of the curve determined. The slope of the curve approaching zero indicates that a substantially constant resistivity has been achieved, thereby reflecting that dry weight has been substantially attained. As the resistivity curve slope approaches zero, the hydration status of the patient approaches dry weight. Optionally, ultrafiltration may be prolonged or otherwise modified until dry weight is achieved during the ongoing hemodialysis treatment session or hemodialysis may be prolonged during the next hemodialysis treatment to remove the excess fluid and achieve dry weight.

In another embodiment, suitable for both hemodialysis and peritoneal dialysis patients, comparison of the body segment resistivity, preferably post dialysis resistivity, of dialysis patients to the body segment resistivity of healthy subjects is used to determine the patients' hydration status and optionally the appropriate end point for dialysis. The circumference of a body segment is measured, preferably at the start and optionally at the end of treatment. The body segment may be the whole body, a limb segment such as a leg, arm, or other extremity, and is preferably a thigh segment or an arm segment. Preferably, at least two injector electrodes 9, at least two measurement electrodes 10, and optionally a pressure cuff 3 are attached to the body segment (*see, for example, Figure 10*). Preferably, the electrodes are incorporated within to the pressure cuff. At least once, preferably about the time that the dialysis treatment is completed, bioimpedance of the body segment is measured. Optionally bioimpedance is measured at the start and end of the dialysis treatment, periodically, during most or all of the dialysis treatment, optionally from about every 10 minutes to about every 20 minutes. Bioimpedance is measured optionally with the body segment uncompressed or preferably, with the body segment compressed, preferably by inflation of the pressure cuff. The injection and measurement of current is coordinated to correspond with time

points when the pressure cuff is substantially fully inflated or substantially deflated.

To measure resistivity, current is injected into the body segment through injector electrodes and the current transmitted through the body segment is received by the measurement electrodes and transmitted to the BIA measurement unit for calculation of the resistivity of the body segment, the derived data optionally being transmitted to the microprocessor system, which, in turn, according to the method disclosed herein.

To obtain a range of normal resistivity values, the bioimpedance of healthy subjects is measured repeatedly at specific body segments, which may be the whole body, preferably a limb segment, more preferably a leg or an arm segment, most preferably a thigh segment, over about 15 minute periods. From these values, a set of normal resistivity values is derived that correlates with dry weights. Preferably a large group of healthy subjects is studied to produce a set of normal resistivity values for a specific population. Optionally, determination of resistivity in subsets of the healthy population can be performed in order to more precisely correlate resistivity values with dialysis patient's dry weight. For example, because fat mass is often an important factor affecting the measurement of body fluid volumes by bioimpedance analysis, mainly due to the association between the conductivity of skin or fat free mass and the amount of fat, stratification of bioimpedance values according to BMI, gender or age optionally may be undertaken.

At any particular time point, the resistivity of the dialysis patient's body segment is compared to the resistivity of the equivalent body segment in healthy subjects, in order to determine the patient's hydration status. When the resistivity of the dialysis patient's body segment is substantially equal to the resistivity in normal subjects, the dialysis patient is determined to be substantially at dry weight, and preferably the patient's body weight is measured. Subsequently, the patient's body weight measured at a different time

point can be compared to the body weight measured at the time that the patient was at about dry weight in order to determine ΔW , the difference between the patient's actual weight and dry weight, and thereby the patient's state of hydration. Using ΔW , the patient's dialysis protocol may be modified so that dry weight is achieved post-dialysis.

5 By way of example, which is not intended to be limiting, if a patient is determined, by comparing resistivity values to those of healthy subjects, to be at dry weight at a mass of X kg, and if at the time of the next dialysis treatment the patient's mass is Y kg and $Y > X$, then $\Delta W = Y - X$, reflecting the amount of excess fluid to be removed by dialysis to achieve dry weight. Preferably, repeated determinations of dry weight by bioimpedance
10 analysis are performed periodically to provide greater precision in determining the dry weight of a particular patient.

It is known that the bioimpedance of a body segment changes as the blood pumped by the heart enters and leaves the body segment with each heart beat. By frequent or continuous injection of current and measurement of segmental bioimpedance,
15 a wave form that reflects the pulse can be derived. Based on this information, the present invention provides a means to determine and monitor the heart rate of a patient prior to, during, or after hemodialysis by means of BIA, according to the equation:

$$HR = 60 / (T_{i+1} - T_i)$$

where HR is the heart rate in beats per minute; and $T_{i+1} - T_i$ is the time period
20 between peaks of any two successive heart beat induced impedance waves, T_i and T_{i+1} , as shown in Figure 7.

In another embodiment of the invention, BIA is optionally used to determine cardiac output in individuals, including, but not limited to healthy subjects, and dialysis patients prior to, during, or following dialysis. Estimation of CO is based on the
25 assumption that there is a high degree of symmetry in the distribution of blood vessels on

both sides of the body and the fact that total blood volume per pulse (stroke volume) can be measured in the segments of the arm (SV_{arm}) and leg (SV_{leg}) using bioimpedance simultaneously (preferably measuring the stroke volume from an arm and an ipsilateral leg (i.e., on the same side of the body)).

5 The equation used to calculate cardiac output is:

$$CO = 2 \times HR(k_3 \times SV_{arm} + k_4 \times SV_{leg}) \text{ (L/min)}$$

where SV_{arm} and SV_{leg} are the stroke volume in the arm and in the leg respectively; SV_{arm} and SV_{leg} are calculated using the following formulas:

$$SV_{arm} = \Delta V_A / N_A \text{ and } SV_{leg} = \Delta V_L / N_L$$

10 where ΔV_A is the change in blood volume in the arm and ΔV_L is the change in the blood volume in the leg between the time point of maximal cuff pressure (shown as segment point A in Figure 8, during which time substantially all the blood volume is squeezed from the limb segment) and the time point when the pressure cuff is deflated (Shown as point B in Figure 8, during which time blood volume is refilled by the stroke
15 volume). N_A and N_L are the number of pulses during changes in impedance from peak point (A) to baseline (B) respectively.

The values for ΔV_A and ΔV_L are calculated as follows:

$$\Delta V_A = -\rho_b L^2 \Delta Z_A / Z_A^2 \text{ and } \Delta V_L = -\rho_b L^2 \Delta Z_L / Z_L^2 \quad \text{Equation 2}$$

20 where ρ_b is the resistivity of blood, L is the length of the body or limb segment between the electrodes, and Z_A and Z_L are each respective impedance values.

Calculations of ΔV_A and ΔV_L are performed according to the method of J. G. Webster in, *Medical Instrumentation Application and Design, 3rd Ed.*, Wiley, New York, 1998 pp. 357 - 362, which is hereby incorporated herein by reference, in its entirety.

25 The coefficients k_3 and k_4 are coefficients of calibration for individuals in ΔV_A and ΔV_L respectively. The calibration is performed by injecting from about 5 ml to

about 150 ml into a vein distal to the arm segment in which resistivity is to be measured, while the resistivity is measured continuously in the arm segment. As the wave of increased volume (ΔV) passes through the segment, there is a change in resistance (ΔR) in relation to the volume injected. Using the relationship between $\Delta V/\Delta R$, k_3 and k_4 are calibrated.

The calibrating process provides the information about how a change in resistance per ohm is related to a known change in volume ($\Delta V/\Delta R$). By definition, define $k_c = \Delta V/\Delta R$ as a calibration coefficient, where ΔV is the volume of injected saline (ml) and ΔR is the change in resistance in the calibrating segment. Thus, k_3 is defined by equation as follows:

$$k_3 = k_c \times \Delta Z_A / (N_A \times V_A)$$

Where ΔZ_A is the change in impedance in the arm, V_A is volume calculated by set, and N_A is number of pulses. Similarly, the equation $k_4 = k_c \times \Delta Z_L / (N_L \times V_L)$ is used to calibrate for changes in the volume of a leg.

One embodiment of a system such as that disclosed in Figure 2, but additionally being capable of measuring cardiac output is shown in Figure 11. Included are two sets of electrodes 9 and 10 and 9' and 10', preferably incorporated into two pressure cuffs 3 and 3' adapted to be attached to a leg segment (not shown) and to an ipsilateral arm segment (not shown), both sets of electrodes being connected to a digital switch, via wiring 11 and 11', capable of rapidly switching between each set of electrodes, so that measurements may be taken from either the leg segment or the arm segment substantially simultaneously. Preferably the digital switch 30 has the capacity to achieve a sampling frequency of at least about 200 Hz and, more preferably, greater than 1 kHz. Optionally, there is a means to send a control signal from a computer 31 to the digital switch so that the sample frequency can be changed as needed.

Listed below are a series of examples of the present invention. The examples contained herein are intended to illustrate, but are not intended to limit the scope of the invention.

Example 1

Twenty healthy subjects (Table 1) and thirteen hemodialysis patients (Table 2) were studied, the latter during hemodialysis. Shown in Tables 1 and 2 are their mean ages, weights and body mass indices (BMI). Data are presented as mean value \pm SD

Table 1: Healthy subjects

	n	Age (years)	Weight (kg)	BMI (kg/m ²)
Male	10	40.8 \pm 5	83.1 \pm 21.6	27.1 \pm 5.0
Female	10	35 \pm 9	64.3 \pm 9.7	24.2 \pm 3.2

Table 2: Hemodialysis patients

	n	Age (year)	Dry Weight (kg)	BMI (kg/m ²)
Male	10	48.5 \pm 12.8	76.8 \pm 16.4	26.8 \pm 4.3
Female	3	65 \pm 14	60.5 \pm 16	23.7 \pm 3.5

Example 2

Segmental bioimpedance was measured continuously every 10 minutes during hemodialysis using 6 electrodes all on the left side of the body. Two electrodes, one on the hand and one on the foot, were used to inject current. Measurement electrodes were placed on the wrist, shoulder, hip and ankle. Resistivity was measured in the wrist-shoulder segment (V_{arm}), the shoulder-hip segment (V_{trunk}), and in the ankle-hip segment (V_{leg}). Also measured were systolic blood pressure (SBP), relative blood volume or hematocrit (RBV), and the ultrafiltration rate (UFR). In this way, blood

volume and segmental extracellular volume (ECV) in the leg, arm and trunk were calculated. The results are shown in Figure 3. The X-axis is time in minutes, the Y-axis the relative change in value with the value of a particular parameter at the start of hemodialysis being equal to 100%. After continuing ultrafiltration changes in ECV of the leg became small that the slope was nearly horizontal i.e. approached 0, which indicates that little fluid was available for ultrafiltration and dry weight had been achieved. Comparing the curves of ECV trunk, leg and arm, it can be seen that the leg is the preferred body segment for dry weight analysis.

Example 3

The resistance and resistivity of a limb segment with and without inflation of a pressure cuff was measured at the start and at the completion of a hemodialysis treatment and ΔW was calculated. Table 3 shows that in a series of patients ΔW was $\neq 0$ at the end of hemodialysis, indicating that these patients were not at their clinical dry weight at the end of hemodialysis.

Table 3 Results in ten male patients and ten male healthy subjects

Subjects	Area (cm ²)	R ₀ (Ω)	R _p (Ω)	ρ ₀ (Ωcm)	ρ _p (Ωcm)	ΔW (L)
Start HD	86.7±20	41.1±6.7	44.3±8	354.8±95	383±106	4.31±1.3
End HD	81±19	53.1±8.4	56.6±9	428.6±116	457.6±125	0.17±0.41
Healthy	98.2±26	49.6±10	54.5±11	500.3±60	547±60	0

In confirmation (Fig.3) both ρ₀ and ρ_p at the end of HD were lower or higher in patients than in healthy subjects. This indicates that most patients were overhydrated (i.e., excess fluids were not removed) while some were dehydrated by the treatment and

had lower than normal fluid volume. It is a purpose of the present invention to have all patients in substantially the same range as healthy subjects after treatment (note resistivity is inversely related to interstitial volume). Fig. 4 shows a high correlation between ΔW and ρ_p which indicates that ρ_p is capable of being used for analysis of patients' segmental hydration so that dry weight could be predicted by this technique.

Example 4

Figure 5 shows the clinical correlation of resistivity and blood pressure at the end of hemodialysis in 10 male patients. Figure 4 shows the clinical correlation between resistivity and body hydration at the end of hemodialysis in these patients. The normal range for resistivity is shown as a solid line. The results demonstrate that the hemodialysis patients were not at the correct dry body weight as indicated by this technique at the end of the treatment. Most were over-hydrated, however the three denoted by the symbol \circ were underhydrated. Using Equation 1 the individual dry weight was calculated according to the healthy subjects' ρ_0 and ρ_p and BMI. The patients' dry weight after correction compared to healthy subjects and uncorrected dry weight are shown in Figure 9.

Throughout this application, various articles and patents are referenced. Disclosures of all of these publications are hereby incorporated herein by reference in their entireties. The present invention may be embodied in other forms without departing from the spirit or essential attributes thereof and accordingly reference should be made to the claims rather than to the foregoing specification as indicating the scope thereof

25

We claim:

1. A method for determining the hydration status of a dialysis patient comprising the steps of:
 - measuring the resistivity of a body segment of the patient;
 - correlating the measured resistivity with predetermined normal dry weight values; and
 - deriving the patient's hydration status.
2. The method of claim 1, wherein the resistivity of the interstitial fluid in the body segment is measured.
3. The method of claim 1, wherein the resistivity of the body segment is determined while applying a pressure of at least about systolic blood pressure.
4. The method of claim 3, wherein the pressure is applied from about 120 mmHg to about 240 mmHg.
5. The method of claim 1, wherein the body segment is a limb segment.
6. The method of claim 1, wherein the body segment is a thigh segment.
7. A method for determining a hemodialysis patient's dry weight comprising the steps of:
 - periodically measuring the resistivity of a body segment during hemodialysis;

comparing successive resistivity measurements; and
identifying the patient's dry weight when a substantially constant resistivity is reached.

8. The method of claim 7, wherein the resistivity of the body segment is measured
from

about every 5 minutes to about every 20 minutes during hemodialysis.

9. The method of claim 8, wherein the resistivity of the body segment is measured
about

every 10 minutes during hemodialysis.

10. The method of claim 7, wherein the resistivity of the body segment is measured at
a

pressure of at least about systolic blood pressure.

11. The method of claim 10, wherein the pressure is from about 120 mmHg to about
240

mmHg.

12. A method for dialysing a patient to the patient's dry weight comprising the steps
of:

measuring the resistivity of a body segment of the patient;

correlating the measured resistivity with predetermined normal dry weight

values; deriving the patient's hydration; and

continuing hemodialysis until the resistivity of the body segment correlates with the
predetermined normal dry weight values.

13. The method of claim 12, wherein the resistivity of the body segment is measured at a
pressure of at least about systolic blood pressure.

14. A method for hemodialysing a patient to the patient's dry weight comprising the
steps
of:
periodically measuring the resistivity of a body segment during hemodialysis;
comparing successive resistivity measurements; and
discontinuing hemodialysis when a substantially constant resistivity is reflected.

15. The method of claim 14, wherein the resistivity of the body segment is measured at a
pressure of at least about systolic blood pressure.

16. The method of claim 14, wherein the resistivity of the body segment is measured from
about every 5 minutes to about every 20 minutes during hemodialysis.

17. A method of monitoring the heart rate of a hemodialysis patient comprising the
steps

of:

determining a time interval between two successive bioimpedance wave peaks;
and
multiplying the reciprocal of the time interval by 60 to obtain the heart rate.

18. A method of calculating the cardiac output of a patient in need thereof comprising the

steps of:

measuring the stroke volume in an arm segment by bioimpedance analysis;
substantially simultaneously measuring the stroke volume in an ipsilateral leg
segment by bioimpedance analysis;

summing the stroke volume in the arm segment and the stroke volume in the leg
segment; and

multiplying the sum by twice the heart rate to obtain the cardiac output.

19. The method of claim 18, wherein stroke volume of the arm segment is calculated
by

applying an external maximum pressure to the arm segment and determining the change
in blood volume in the arm segment between the point of maximum pressure and the point
at which no external pressure is applied divided by the number of heart beats between
the two points in time, and wherein the stroke volume of the leg is calculated by applying
an external maximum pressure to the leg segment and determining the change in blood
volume in the leg segment between the point of maximum pressure and the point at which
no external pressure is applied divided by the number of heart beats between two points
in time.

20. A device for controlling a hemodialysis machine comprising:
a bioimpedance analysis measurement unit in electrical communication with a hemodialysis machine;
an electrical output means being in electrical communication with the bioimpedance analysis measurement unit and being attachable to a body segment, the electrical output means being adapted to apply electrical current to the body segment;
an electrical input means being in electrical communication with the bioimpedance analysis measurement unit and being attachable to a body segment, the electrical input means being adapted to receive the current transmitted through the body segment and transmit the same to the bioimpedance analysis measurement unit; and
wherein the bioimpedance analysis measurement unit is adapted to determine body segment resistivity based on the current transmitted through the body segment and wherein the bioimpedance analysis measurement unit provides feedback to the hemodialysis machine in response to the body segment resistivity.
21. The device of claim 20 further including means for applying pressure to the body segment, the pressure applying means being in electrical communication with the bioimpedance analysis measurement unit.
22. The device of claim 21 wherein the pressure applying means includes a pressure cuff,
the pressure cuff being adapted to encircle the body segment.
23. The device of claim 22 wherein the electrical output means includes at least two

injector electrodes, the electrical input means includes at least two measurement electrodes, and wherein the injector electrodes and the measurement electrodes are secured to the pressure cuff.

24. The device of claim 23 wherein the pressure cuff further includes at least one conductive band with opposing ends and at least one conductive plate positioned adjacent one of the ends of the conductive band, the conductive band extends substantially the length of the pressure cuff, the conductive plate is arranged to electrically contact the conductive band at a point along the length of the same wherein the distance between the conductive plate and the point of contact of the conductive band is substantially equal to the circumference of the body segment, and wherein the bioimpedance measurement unit is adapted to electrically determine body segment circumference based on the distance between the end of the band adjacent to the plate and the point of contact of the plate along the length of the band.

25. A device for monitoring hydration status in a hemodialysis patient comprising:
a bioimpedance analysis measurement unit;
an electrical output means being in electrical communication with the bioimpedance analysis measurement unit and being attachable to a body segment, the electrical output means being adapted to apply electrical current to the body segment;
an electrical input means being in electrical communication with the bioimpedance analysis measurement unit and being attachable to a body segment, the electrical input means being adapted to receive the current transmitted through the body segment and transmit the same to the bioimpedance analysis measurement unit; and

wherein the bioimpedance analysis measurement unit is adapted to determine body segment resistivity based on the current transmitted through the body segment.

26. The device of claim 25 further including means for applying pressure to the body segment, the pressure applying means being in electrical communication with the bioimpedance analysis measurement unit.

27. The device of claim 26 wherein the pressure applying means includes a pressure cuff, the pressure cuff being adapted to encircle the body segment.

28. The device of claim 27 wherein the electrical output means includes at least two injector electrodes, the electrical input means includes at least two measurement electrodes, and wherein the injector electrodes and the measurement electrodes are secured to the pressure cuff.

29. The device of claim 28 wherein the pressure cuff further includes at least one conductive band with opposing ends and a conductive plate positioned adjacent one of the ends of the conductive band, the conductive band extends substantially the length of the pressure cuff, the conductive plate is arranged to electrically contact the conductive band at a point along the length of the same wherein the distance between the conductive plate and the point of contact of the conductive band is substantially equal to the circumference of the body segment, and wherein the bioimpedance measurement unit is adapted to electrically determine body segment circumference based on the distance between the end of the band adjacent to the plate and the point of contact of the plate

along the length of the band.

30. A hemodialysis machine including the device of claim 25.

31. A device for calculating cardiac output through bioimpedance measurements of a patient comprising:

a bioimpedance measurement unit;

a first electrical output means being in electrical communication with the bioimpedance analysis measurement unit and being attachable to an arm segment, the first electrical output means being adapted to apply electrical current to the arm segment;

a second electrical output means being in electrical communication with the bioimpedance analysis measurement unit and being attachable to a leg segment, the second electrical output means being adapted to apply electrical current to the leg segment;

a first electrical input means being in electrical communication with the bioimpedance analysis measurement unit and being attachable to an arm segment, the electrical input means being adapted to receive the current transmitted through the arm segment and transmit the same to the bioimpedance analysis measurement unit;

a second electrical input means being in electrical communication with the bioimpedance analysis measurement unit and being attachable to a leg segment, the electrical input means being adapted to receive the current transmitted through the leg segment and transmit the same to the bioimpedance analysis measurement unit;

a first pressure applying means for applying a maximum pressure to the arm segment; pressure to the body segment, the first pressure applying means being in electrical communication with the bioimpedance analysis measurement unit.

a second pressure applying means for applying a maximum pressure to the arm segment, the second pressure applying means being in electrical communication with the bioimpedance analysis measurement unit;

means for selectively electronically connecting the bioimpedance analysis measurement between the first electrical input and output means and the second electrical input and output means, and

wherein the bioimpedance analysis measurement unit is adapted to selectively measure stroke volume in the arm and leg segments by bioimpedance analysis.

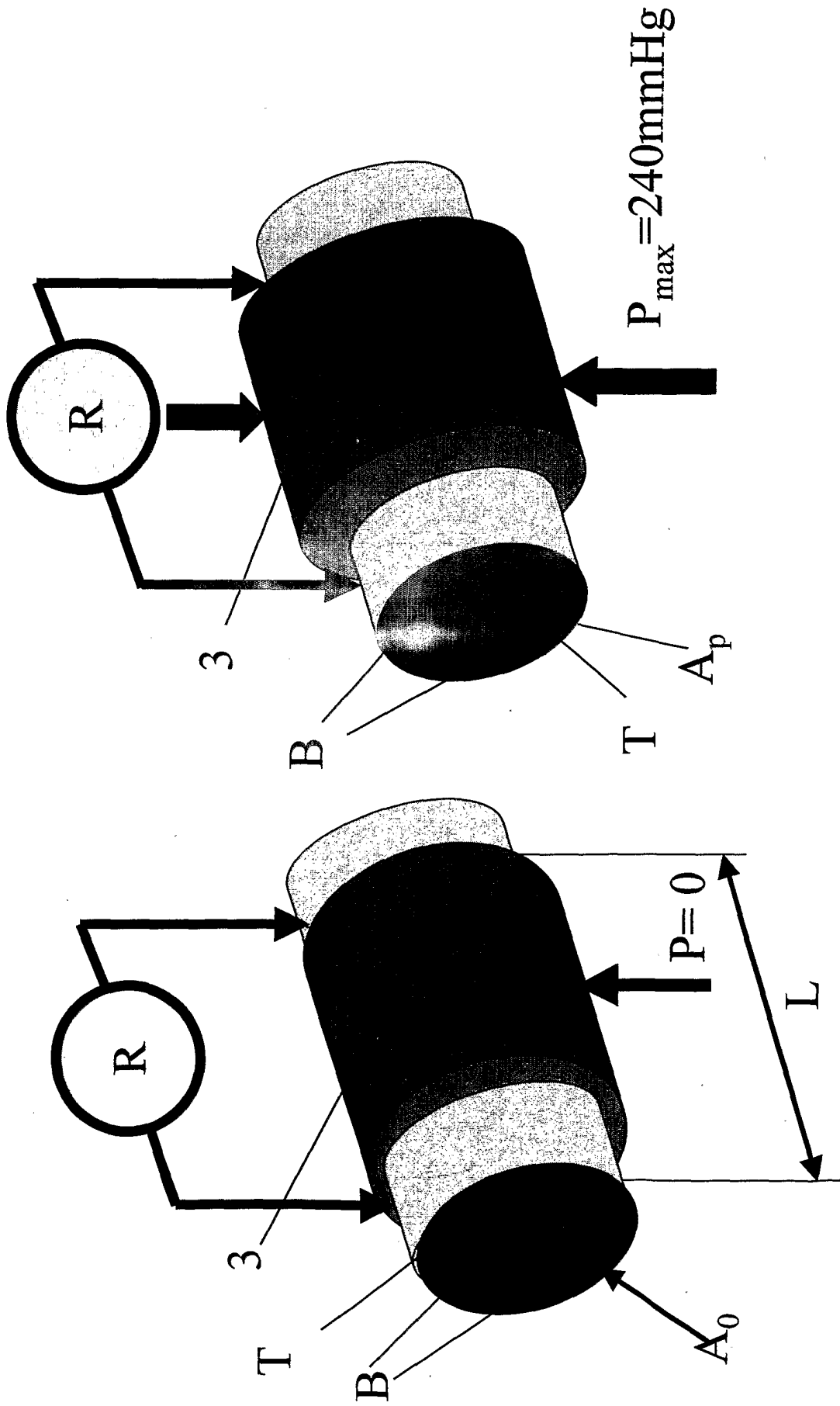

Figure 1B

Figure 1A

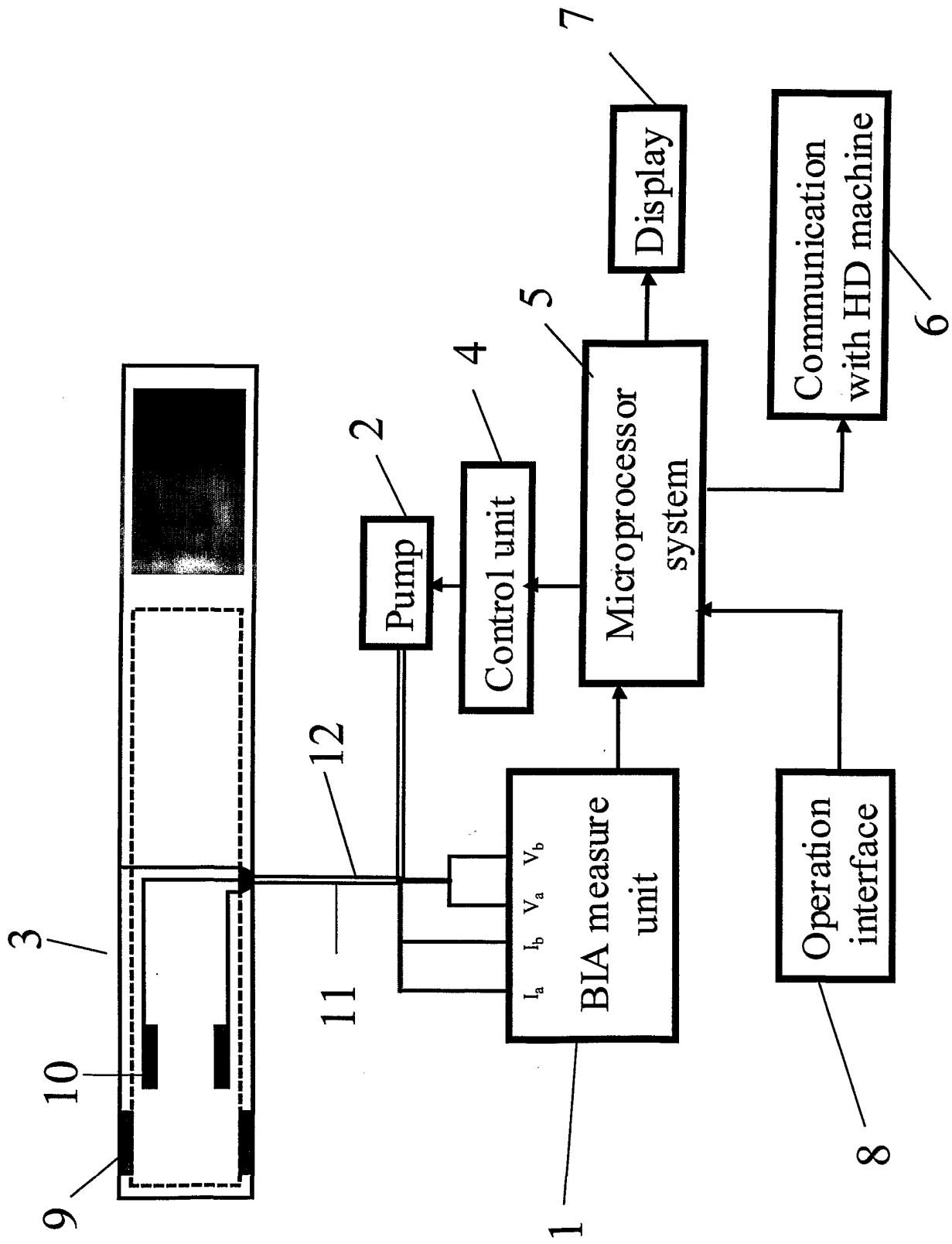
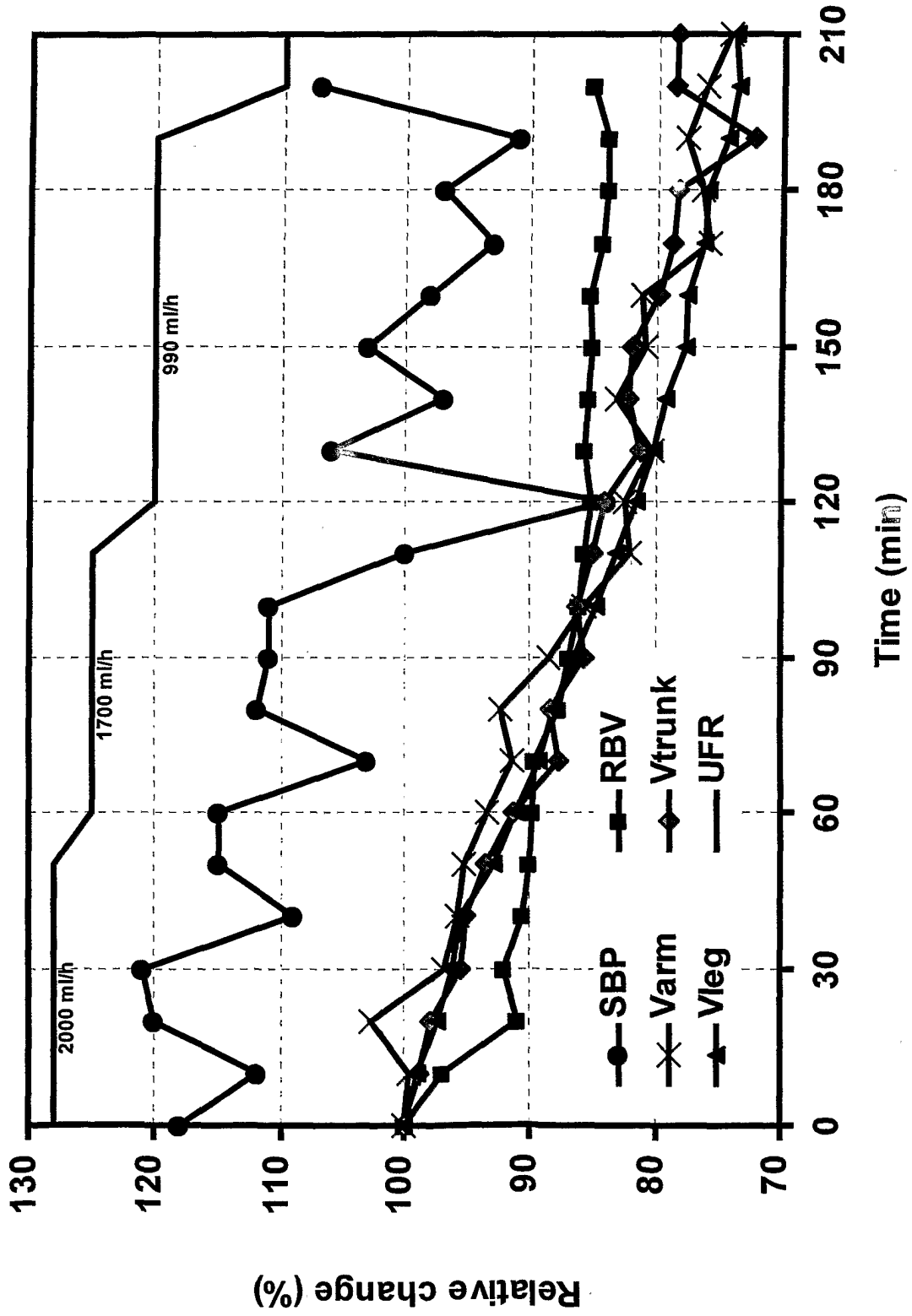

Fig.2

Fig. 3



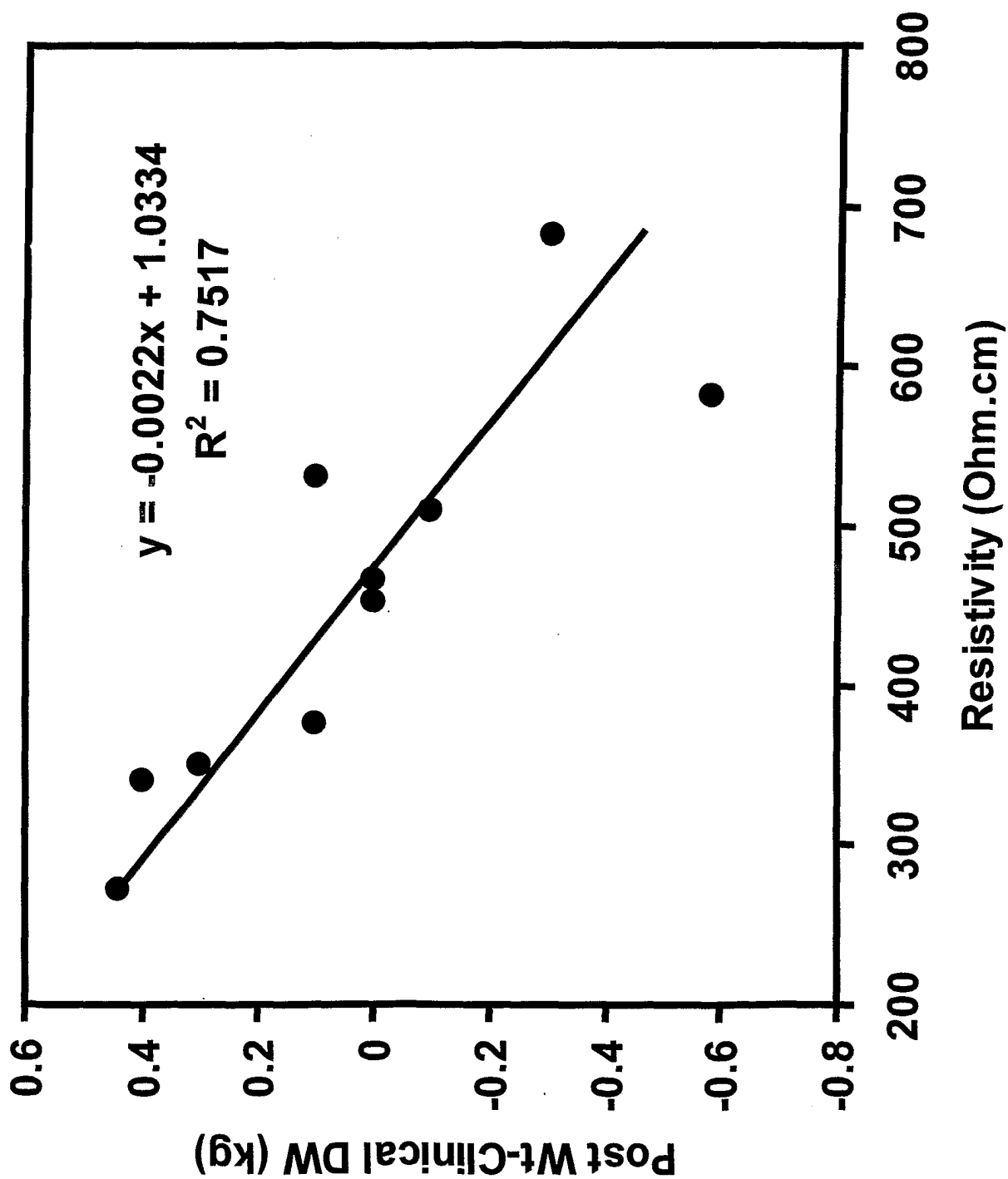

Fig. 4

Fig.5
Blood Pressure at end HD (mmHg)

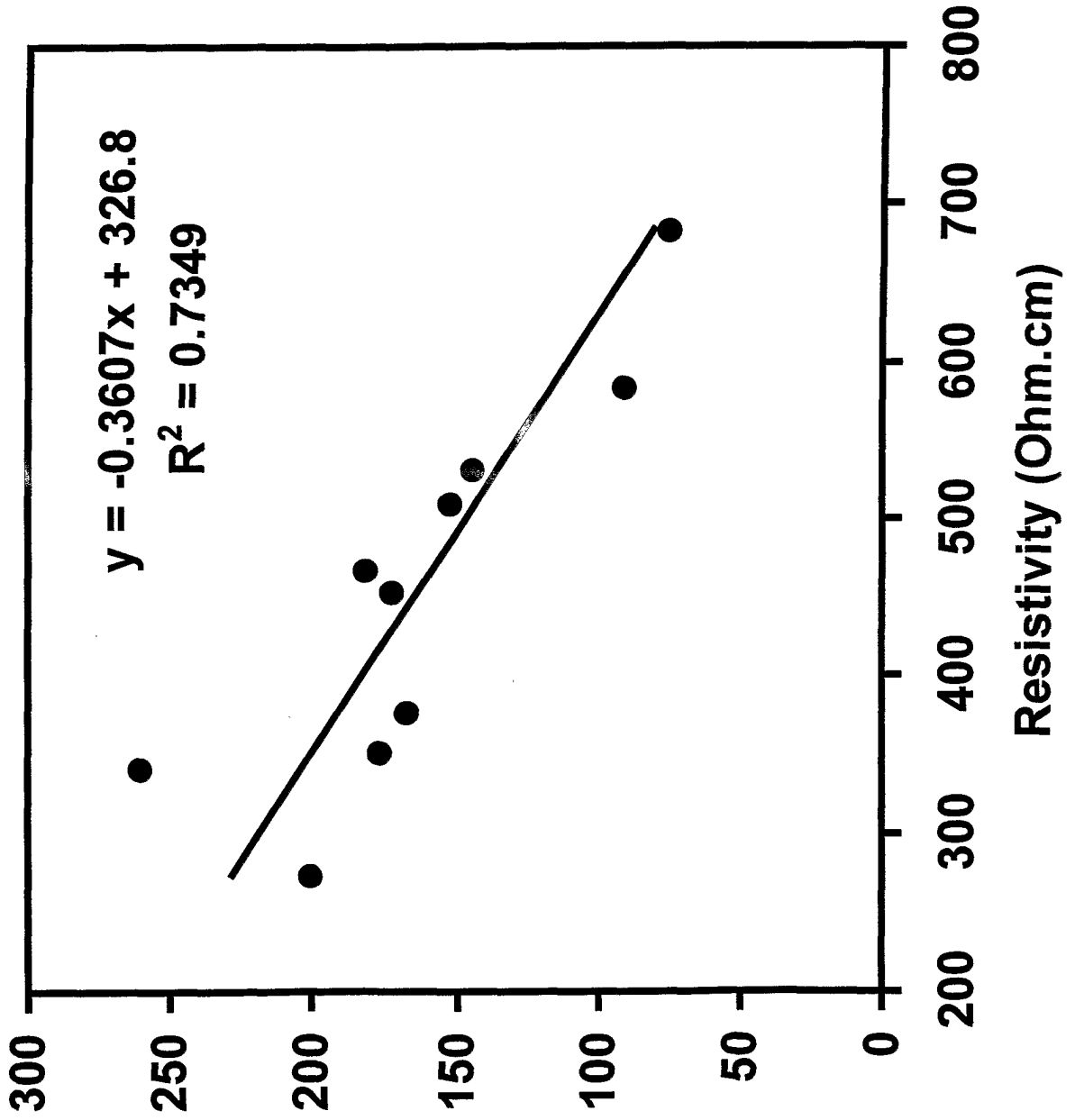
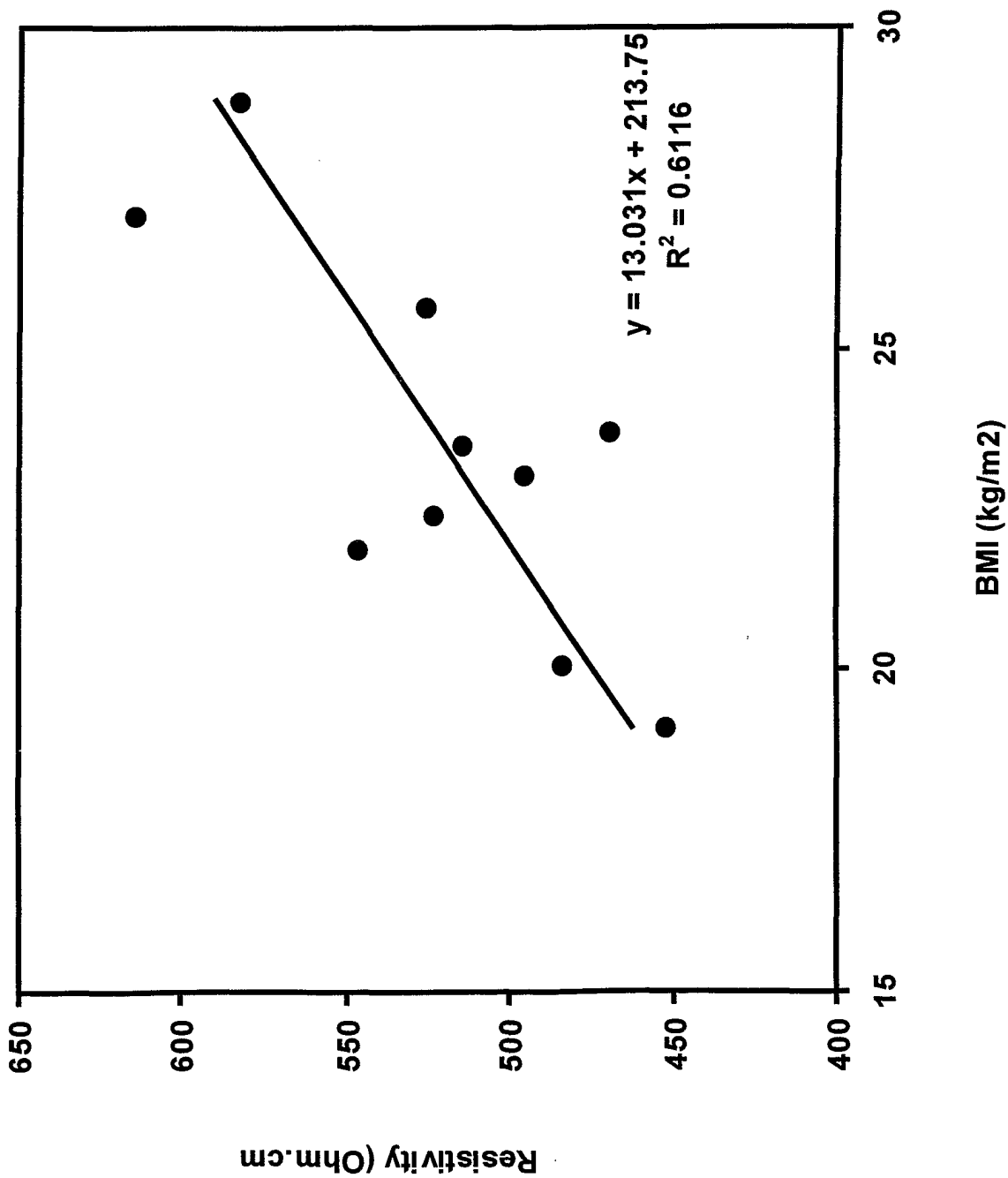

Fig. 6



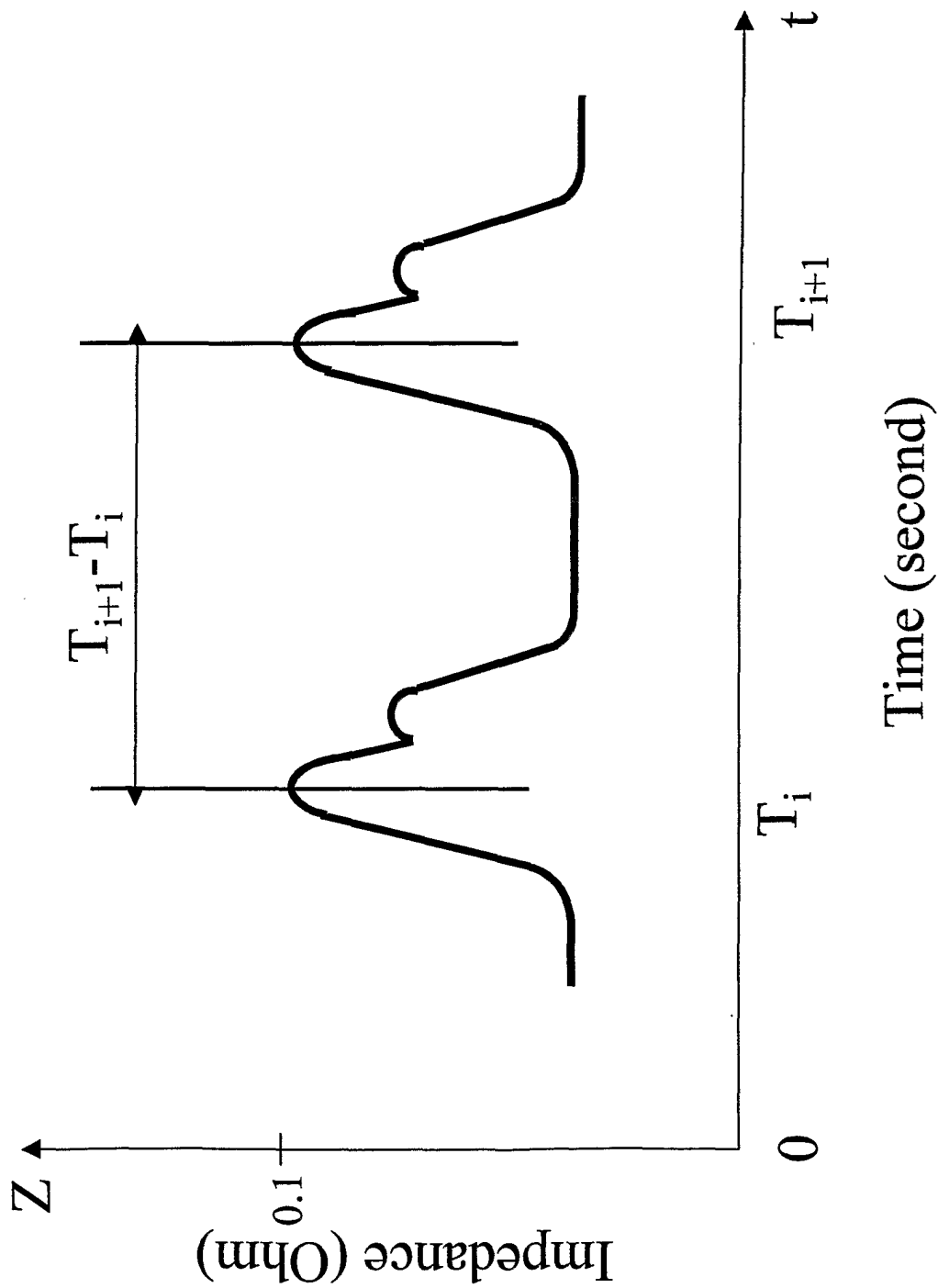

Fig. 7

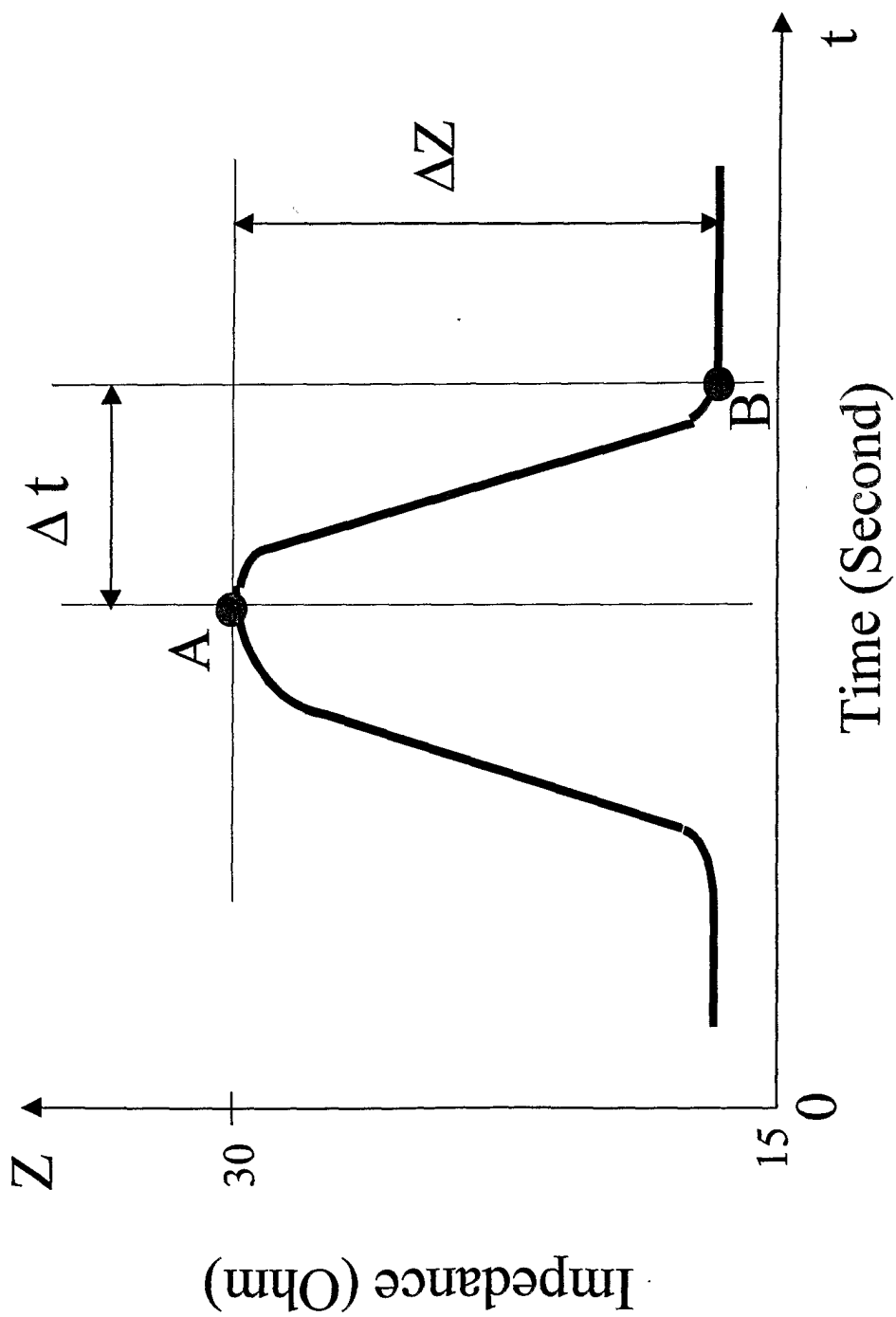

Fig.8

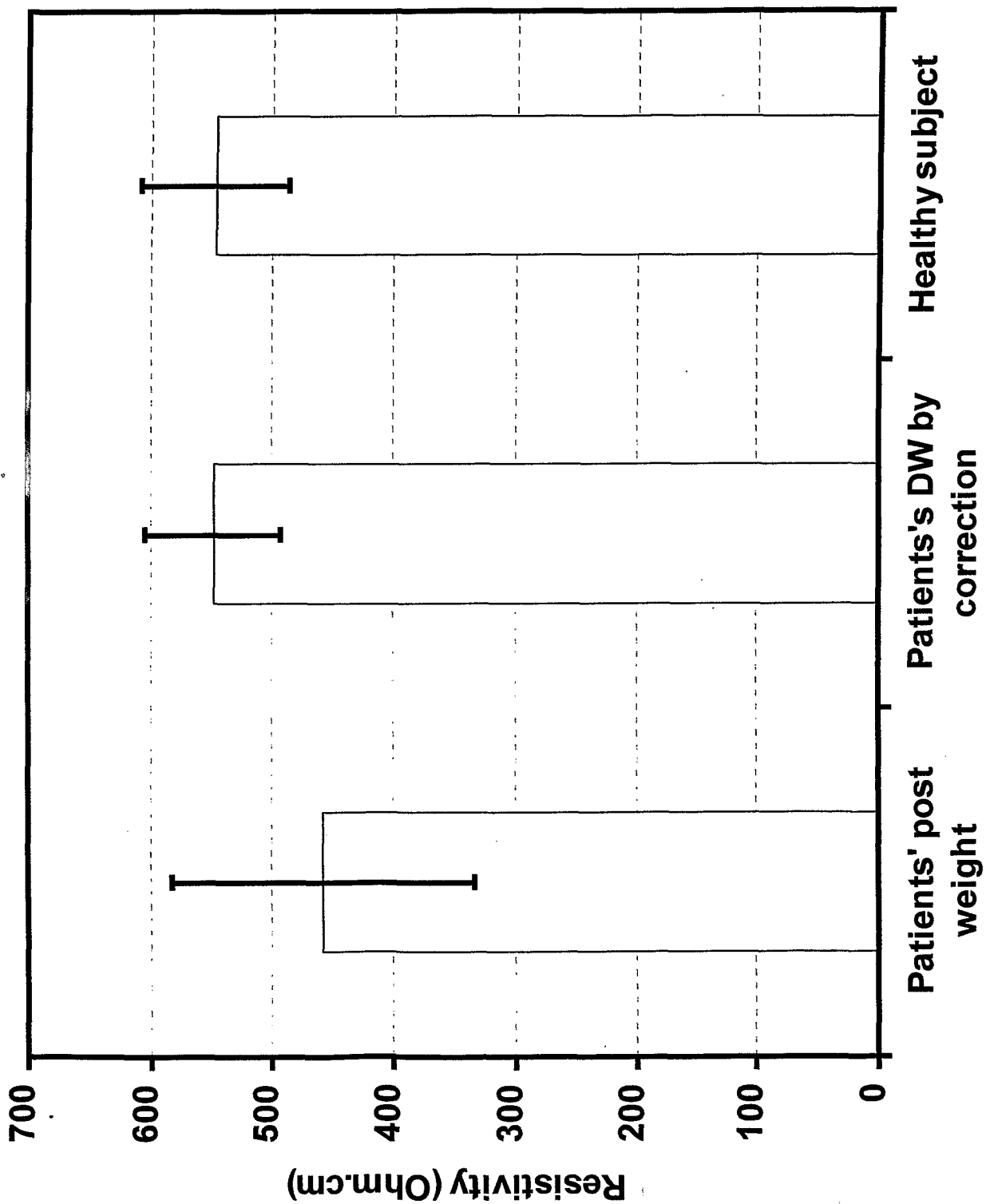

Fig.9

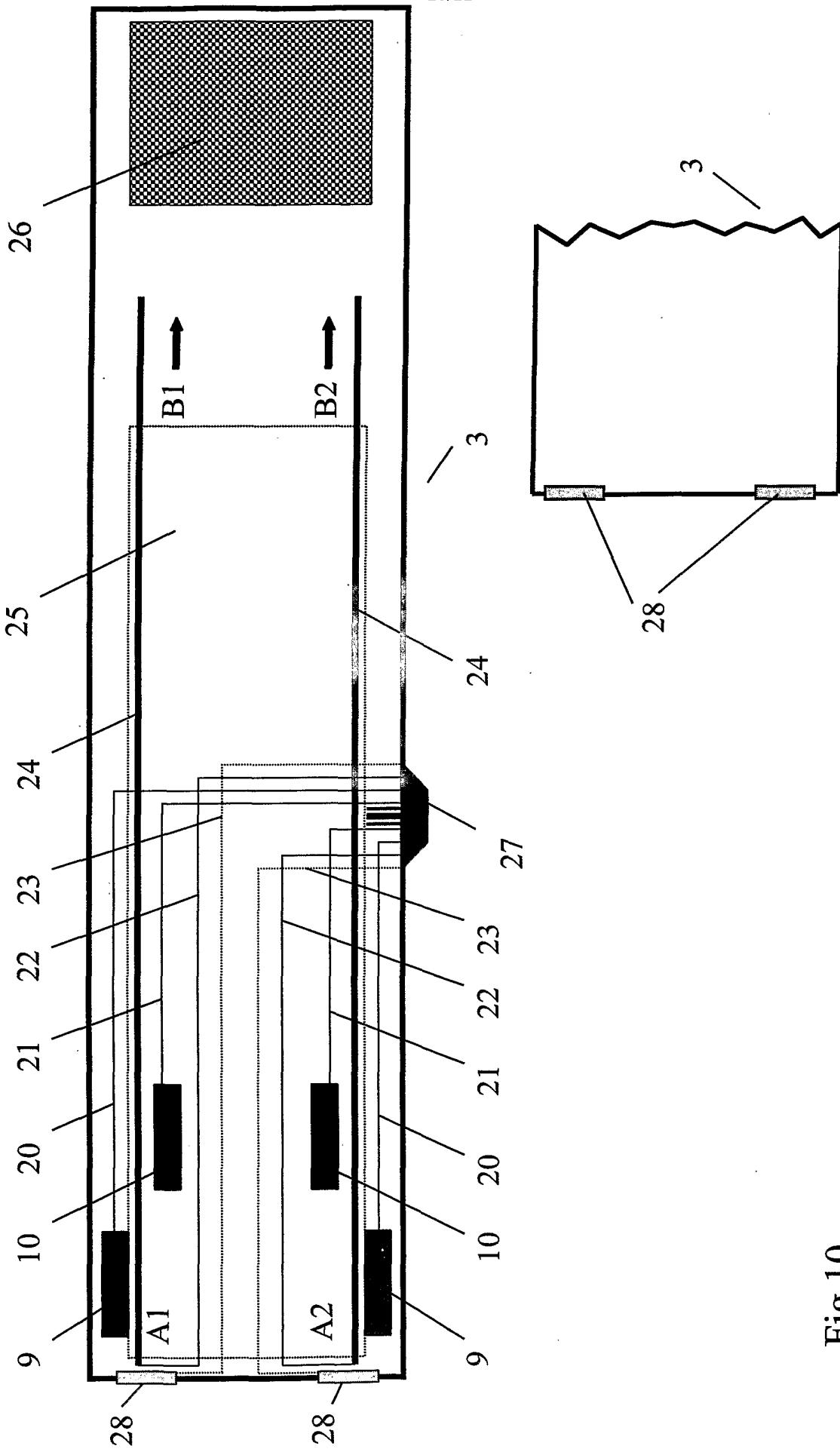

Fig.10

Fig 10A

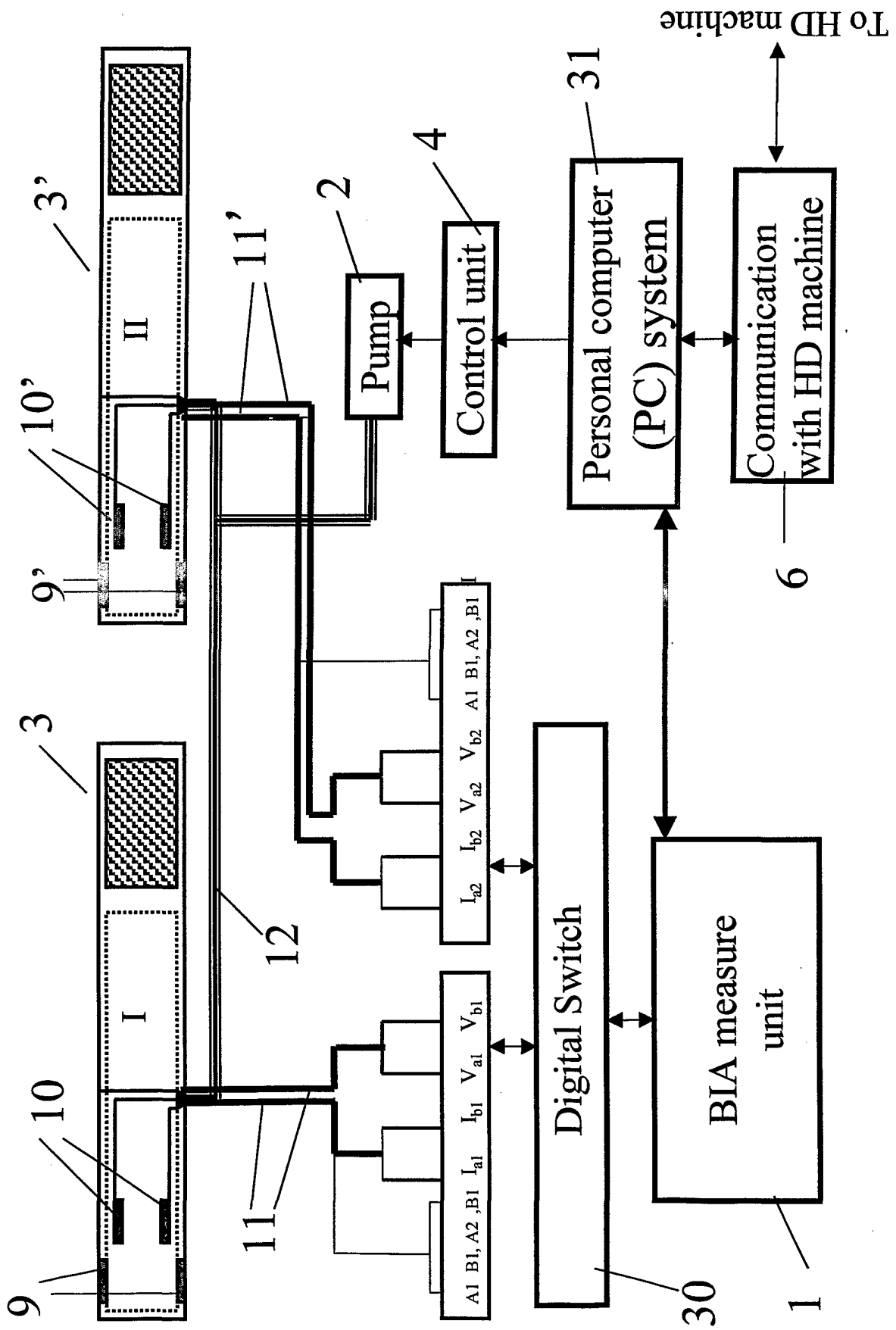

Fig. 11

INTERNATIONAL SEARCH REPORT

International Application No
PCT/US 01/25309

A. CLASSIFICATION OF SUBJECT MATTER
IPC 7 A61B5/05 A61M1/16

According to International Patent Classification (IPC) or to both national classification and IPC

B. FIELDS SEARCHED

Minimum documentation searched (classification system followed by classification symbols)
IPC 7 A61M A61B

Documentation searched other than minimum documentation to the extent that such documents are included in the fields searched

Electronic data base consulted during the international search (name of data base and, where practical, search terms used)

PAJ, EPO-Internal, WPI Data, INSPEC, COMPENDEX

C. DOCUMENTS CONSIDERED TO BE RELEVANT

Category °	Citation of document, with indication, where appropriate, of the relevant passages	Relevant to claim No.
X	US 4 370 983 A (LICHTENSTEIN ERIC S) 1 February 1983 (1983-02-01)	20, 25, 30
Y	column 5, line 53 - line 59; claim 16	21, 22, 26, 27
A	column 6, line 40 - line 56 column 16, line 40 - line 47 --- -/--	31

Further documents are listed in the continuation of box C.

Patent family members are listed in annex.

° Special categories of cited documents :

- *A* document defining the general state of the art which is not considered to be of particular relevance
- *E* earlier document but published on or after the international filing date
- *L* document which may throw doubts on priority claim(s) or which is cited to establish the publication date of another citation or other special reason (as specified)
- *O* document referring to an oral disclosure, use, exhibition or other means
- *P* document published prior to the international filing date but later than the priority date claimed

- *T* later document published after the international filing date or priority date and not in conflict with the application but cited to understand the principle or theory underlying the invention
- *X* document of particular relevance; the claimed invention cannot be considered novel or cannot be considered to involve an inventive step when the document is taken alone
- *Y* document of particular relevance; the claimed invention cannot be considered to involve an inventive step when the document is combined with one or more other such documents, such combination being obvious to a person skilled in the art.
- *G* document member of the same patent family

Date of the actual completion of the international search

14 January 2002

Date of mailing of the international search report

29/01/2002

Name and mailing address of the ISA
European Patent Office, P.B. 5818 Patentlaan 2
NL - 2280 HV Rijswijk
Tel. (+31-70) 340-2040, Tx. 31 651 epo nl,
Fax: (+31-70) 340-3016

Authorized officer

Knüpling, M

INTERNATIONAL SEARCH REPORT

Inter: 1af Application No
PCT/US 01/25309

C.(Continuation) DOCUMENTS CONSIDERED TO BE RELEVANT		
Category °	Citation of document, with indication, where appropriate, of the relevant passages	Relevant to claim No.
X	FANSAN ZHU ET AL: "Estimation of volume of fluid in the peritoneal cavity by bioimpedance analysis" BMES/EMBS CONFERENCE, 1999. PROCEEDINGS OF THE FIRST JOINT ATLANTA, GA, USA 13-16 OCT. 1999, PISCATAWAY, NJ, USA, IEEE, US, 13 October 1999 (1999-10-13), page 798 XP002187323 ISBN: 0-7803-5674-8	20, 25, 30
Y	the whole document	21, 22, 26, 27
A		31
X	WO 98 51211 A (AHER ANTS; SILEM HEIKI (EE); LAMP JUERGEN (EE); KOEOEBI TIIT (FI)) 19 November 1998 (1998-11-19)	31
Y	page 2, line 17 - line 19	21, 22, 26, 27
	page 9, line 5 - line 29 page 10, line 16 - line 17 page 12, line 13 - line 28 page 13, line 24 - line 35	
A	page 17, line 18 - line 31	20, 23, 28, 31
Y	US 4 204 545 A (YAMAKOSHI KENICHI) 27 May 1980 (1980-05-27) column 1, line 7 - line 12	21, 22, 26, 27
A	column 3, line 4 - line 46	20, 23, 28, 31
A	GB 2 069 706 A (ASULAB AG) 26 August 1981 (1981-08-26) page 6, line 19 - line 33	20-29, 31
A	SHIMAZU H ET AL: "ELECTRIC IMPEDANCE CUFF FOR THE INDIRECT MEASUREMENT OF BLOOD PRESSURE AND VOLUME ELASTIC MODULUS IN HUMAN LIMB AND FINGER ARTERIES" MEDICAL AND BIOLOGICAL ENGINEERING AND COMPUTING, PETER PEREGRINUS LTD. STEVENAGE, GB, vol. 27, no. 5, 1 September 1989 (1989-09-01), pages 477-483, XP000046402 ISSN: 0140-0118 page 478, section 2.1 "Electric impedance cuff"	20-23, 25, 28, 31

INTERNATIONAL SEARCH REPORT

 International Application No
 PCT/US 01/25309

Patent document cited in search report		Publication date	Patent family member(s)	Publication date
US 4370983	A	01-02-1983	US 3946731 A	30-03-1976
			US 3912455 A	14-10-1975
			AU 5999380 A	20-11-1980
			DE 3068781 D1	06-09-1984
			EP 0027470 A1	29-04-1981
			JP 56500993 T	23-07-1981
			WO 8002376 A1	13-11-1980
			US 4464172 A	07-08-1984
			IL 49953 A	31-07-1980
			AU 7300574 A	11-03-1976
			CA 1034459 A1	11-07-1978
			CH 612587 A5	15-08-1979
			CH 594418 A5	13-01-1978
			DE 2442086 A1	20-03-1975
			ES 429812 A1	01-09-1976
			FR 2242994 A1	04-04-1975
			GB 1492386 A	16-11-1977
			IE 40006 B1	14-02-1979
			JP 50072494 A	16-06-1975
			SE 7411321 A	10-03-1975
SE 8200621 A	03-02-1982			
BE 819642 A1	31-12-1974			
GB 1492387 A	16-11-1977			
IE 40007 B1	14-02-1979			
ZA 7405558 A	29-10-1975			
US 3774762 A	27-11-1973			
WO 9851211	A	19-11-1998	EP 1014852 A1	05-07-2000
			WO 9851211 A1	19-11-1998
			US 6228033 B1	08-05-2001
US 4204545	A	27-05-1980	JP 1408252 C	27-10-1987
			JP 54041584 A	02-04-1979
			JP 62013013 B	23-03-1987
			CA 1104373 A1	07-07-1981
GB 2069706	A	26-08-1981	CH 642835 A5	15-05-1984
			DE 3014198 A1	27-08-1981
			FR 2475883 A1	21-08-1981
			IT 1135510 B	27-08-1986
			JP 56130140 A	12-10-1981
			US 4429699 A	07-02-1984

专利名称(译)	用于透析患者的节段生物阻抗测量的装置和方法		
公开(公告)号	EP1309273A1	公开(公告)日	2003-05-14
申请号	EP2001963952	申请日	2001-08-13
[标]申请(专利权)人(译)	肾RES INST		
申请(专利权)人(译)	肾脏研究院有限责任公司		
当前申请(专利权)人(译)	肾脏研究院有限责任公司		
[标]发明人	ZHU FANSAN LEVIN NATHAN		
发明人	ZHU, FANSAN LEVIN, NATHAN		
IPC分类号	A61B5/00 A61B5/022 A61B5/0245 A61B5/026 A61B5/05 A61B5/053 A61M1/14 A61M1/16		
CPC分类号	A61B5/022 A61B5/0535 A61B5/0537 A61B5/4869 A61M1/16 A61M2205/3393 A61M2205/50		
优先权	09/638657 2000-08-14 US		
其他公开文献	EP1309273B1		
外部链接	Espacenet		

摘要(译)

本发明包括通过节段生物阻抗分析确定进行透析的患者的干体重的方法。在优选的实施方案中，通过与正常受试者的生物阻抗值比较或通过监测透析期间生物阻抗的变化来确定干体重。本发明的一个实施方案是一种用于在透析期间确定干体重的装置。