



(51) International Patent Classification:

A61B 5/00 (2006.01) A61B 5/0444 (2006.01)
A61B 5/024 (2006.01) A61B 8/08 (2006.01)
A61B 5/0245 (2006.01) A61B 8/02 (2006.01)
A61B 5/113 (2006.01)

(21) International Application Number:

PCT/IB2013/055420

(22) International Filing Date:

2 July 2013 (02.07.2013)

(25) Filing Language:

English

(26) Publication Language:

English

(30) Priority Data:

61/670,648 12 July 2012 (12.07.2012) US

(71) Applicant (for all designated States except DE): **KONINKLIJKE PHILIPS N.V.** [NL/NL]; High Tech Campus 5, NL-5656 AE Eindhoven (NL).

(71) Applicant (for DE only): **PHILIPS DEUTSCHLAND GMBH** [DE/DE]; Lübeckertordamm 5, 20099 Hamburg (DE).

(72) Inventors: **REUTER, Stefan Benjamin**; c/o High Tech Campus, Building 5, NL-5656 AE Eindhoven (NL). **WOHLSCHLAGER, Markus**; c/o High Tech Campus, Building 5, NL-5656 AE Eindhoven (NL). **GEYWITZ,**

Hansjoerg; c/o High Tech Campus, Building 5, NL-5656 AE Eindhoven (NL).

(74) Agents: **STEFFEN, Thomas** et al.; High Tech Campus Building 5, NL-5656 AE Eindhoven (NL).

(81) Designated States (unless otherwise indicated, for every kind of national protection available): AE, AG, AL, AM, AO, AT, AU, AZ, BA, BB, BG, BH, BN, BR, BW, BY, BZ, CA, CH, CL, CN, CO, CR, CU, CZ, DE, DK, DM, DO, DZ, EC, EE, EG, ES, FI, GB, GD, GE, GH, GM, GT, HN, HR, HU, ID, IL, IN, IS, JP, KE, KG, KN, KP, KR, KZ, LA, LC, LK, LR, LS, LT, LU, LY, MA, MD, ME, MG, MK, MN, MW, MX, MY, MZ, NA, NG, NI, NO, NZ, OM, PA, PE, PG, PH, PL, PT, QA, RO, RS, RU, RW, SC, SD, SE, SG, SK, SL, SM, ST, SV, SY, TH, TJ, TM, TN, TR, TT, TZ, UA, UG, US, UZ, VC, VN, ZA, ZM, ZW.

(84) Designated States (unless otherwise indicated, for every kind of regional protection available): ARIPO (BW, GH, GM, KE, LR, LS, MW, MZ, NA, RW, SD, SL, SZ, TZ, UG, ZM, ZW), Eurasian (AM, AZ, BY, KG, KZ, RU, TJ, TM), European (AL, AT, BE, BG, CH, CY, CZ, DE, DK, EE, ES, FI, FR, GB, GR, HR, HU, IE, IS, IT, LT, LU, LV, MC, MK, MT, NL, NO, PL, PT, RO, RS, SE, SI, SK, SM, TR), OAPI (BF, BJ, CF, CG, CI, CM, GA, GN, GQ, GW, KM, ML, MR, NE, SN, TD, TG).

[Continued on next page]

(54) Title: METHOD FOR IMPROVED DETERMINATION OF MATERNAL HEART RATE AND FETAL MONITORING SYSTEM THERETO

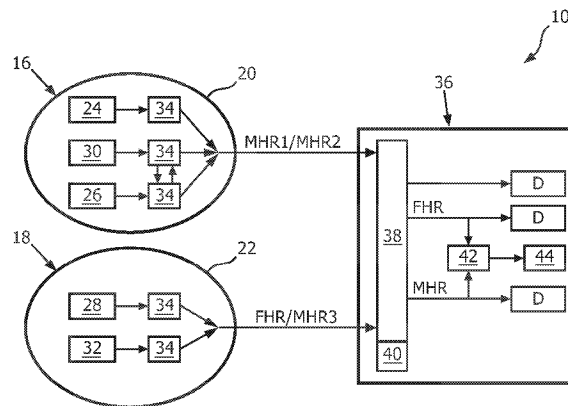

FIG. 2

(57) Abstract: A method for determining at least one maternal physiological parameter out of a heart rate and a breathing rate, comprising the following steps: (a) attaching at least two transducers units (16, 18) of a fetal monitoring system (10) to a maternal abdomen (14); (b) evaluating an acceleration signal regarding at least one out of frequency, amplitude, and signal pattern to derive an acceleration signal corresponding to the at least one maternal physiological parameter; a fetal monitoring system (10), comprising at least two transducers units (16, 18), at least one transducer (24, 26, 28) provided for taking up physiological parameters, at least a first signal processing unit (34), and at least one acceleration sensor (30, 32) different from the at least two transducers (24, 26, 28), wherein the at least one acceleration sensor (30, 32), in at least one operating mode, is rigidly mounted inside a housing (20, 22) of one of the at least two transducer units (16, 18); and wherein the first signal processing unit (34) is provided to evaluate the acceleration signal regarding at least one out of frequency, amplitude, and signal pattern to derive an acceleration signal corresponding to at least one maternal physiological parameter; and a transducer unit (16, 18) for use in a fetal monitoring system (10).



Published:

— with international search report (Art. 21(3))

— before the expiration of the time limit for amending the claims and to be republished in the event of receipt of amendments (Rule 48.2(h))

Method for improved determination of maternal heart rate and fetal monitoring system thereto

FIELD OF THE INVENTION

The invention pertains to a method for determining at least one maternal physiological parameter out of a heart rate and a breathing rate by using a fetal monitoring system, to a fetal monitoring system, and to a sensor unit for use in a fetal monitoring system.

5

BACKGROUND OF THE INVENTION

In the field of fetal monitoring, i.e. the field of measurement and visualization of more than one physiological parameter of unborn human beings, it is known to use monitoring systems comprising multiple transducers for measuring uterine activity and a fetal heart beat. Basically two methods are applied:

10

An external or indirect method employs a use of external transducers placed on the maternal abdomen. Typically, ultrasound (US) Doppler transducers are used in this category, wherein high frequency sound waves reflect mechanical action of a fetal heart.

15

The other method is an internal or direct method that uses a spiral electrode to convert a fetal electrocardiogram obtained from a presenting part of the unborn. This method can be used only when the presenting part is accessible and identifiable. Because of the limited scope of application for the invention, this method shall therefore not be considered in further detail herein.

20

Fetal monitoring systems of the prior art also provide measurements for maternal parameters like electro-cardiogram (ECG), oxygen saturation by pulse oximetry (SpO₂), blood pressure (NBP) or temperature. Generally speaking, a designer of fetal monitoring systems has to make a trade-off between providing extensive monitoring and facilitating a most natural birth without hindering cables and sensors.

25

Monitoring systems using ultrasound Doppler technology are normally able to accurately calculate the fetal heart rate. However, a Doppler signal is composed of reflections from all moving structures in a maternal body. Normally, these stem from the fetal heart beat only, but also reflections from maternal vessels like the aorta or other abdominal vessels may contribute to the Doppler signal. In most cases, maternal and fetal heart rates are easy to

distinguish, because the frequency of a fetal signal is much higher than a maternal heart rate. In case of maternal stress or drug delivery as well as in the case of decreased fetal heart rates, the two heart rates may converge or even become inverted. Because the fetal monitoring technology cannot detect a difference between a fetal and a maternal signal source when
5 applying a transducer for picking up a fetal heart rate, producing a continuous maternal heart rate trace is the recommended method.

Most fetal monitoring systems have built-in comparison algorithms for identifying duplication of heart rates. This feature helps to detect trace coincidences. Question marks are automatically printed whenever two recorded heart rate traces show
10 similarities over a certain amount of time.

The methods described above for obtaining the maternal heart rate require either additional sensors or at least additional electrodes. Electrodes and sensors add additional cables, thus increasing patient and caregiver inconvenience. As a result, any method that adds additional sensors or electrodes is not well accepted.

15 It is therefore desirable to provide a method for determining at least one maternal physiological parameter such as a maternal heart rate that is both reliable and robust without employing additional sensors, electrodes, or the like.

SUMMARY OF THE INVENTION

20 In one aspect of the present invention, the object is achieved by a method for determining at least one maternal physiological parameter out of a heart rate and a breathing rate, comprising the following steps:

(a) attaching at least two transducers units (16, 18) of a fetal monitoring system to a maternal abdomen, the fetal monitoring system further comprising

25 at least one transducer provided for taking up physiological parameters and converting them into corresponding signals;

at least one signal processing unit provided to process signals;

at least one acceleration sensor provided for converting mechanical acceleration at the maternal abdomen into a corresponding acceleration signal, wherein the at
30 least one acceleration sensor is different from the at least one transducer, and wherein the at least one acceleration sensor, in at least one operating mode, is rigidly mounted inside a housing that at least partially encompasses at least one of the at least two transducers;

(b) evaluating the acceleration signal regarding at least one out of frequency, amplitude, and signal pattern to derive an acceleration signal corresponding to the at least one maternal physiological parameter.

The phrase “transducer”, as used in this application, shall be understood particularly as a means for converting one form of energy into another form of energy, in particular, for converting mechanical energy or radiant energy into electric energy, and vice versa. Exemplary transducers that shall be encompassed are passively operated transducers such as pressure-sensitive sensors, as well as transducers that are actively operated at one time of operation and are passively operated at another time of operation, such as ultrasound Doppler transducers.

By this method, an additional signal from an independent source can be obtained that allows for confirmation of physiological data and thus, for prevention of mistakes. It therefore provides a reduced risk of misinterpreting the fetal physiological parameter, while maintaining operating comfort to caregivers and ease to the child-bearing or birth giving mother, as the maternal physiological parameter can be determined in a reliable and robust manner without employing additional sensors, electrodes, or the like.

In a further aspect of the invention, the method further comprises the steps of (c) determining and tracking a cross-channel verification between the acceleration signal and at least one signal of the at least one transducer corresponding to a fetal heart rate; and

(d) depending on a result of the cross-channel verification, activating an alert signal.

The phrase “cross-channel verification”, as used in this application, shall be understood particularly as any method of obtaining a measure of similarity between two signals in a timely domain, and shall in particular encompass methods derived from a frequency analysis of the two signals. By that, the acceleration signal can be employed as a signal from an independent source to check against a fetal heart rate signal obtained from one of the transducers, and a risk for misinterpreting the maternal physiological parameter, such as a maternal heart rate, as a fetal physiological parameter such as a fetal heart rate, is substantially reduced.

In yet another aspect of the present invention, the method further comprises the step of

(c2) selecting one out of the transducer signals and the accelerator signal, based on an evaluation of at least one out of signal history and signal quality.

Thereby, a desired continuous trace of the maternal physiological parameter can be kept to a higher degree, with a lower number of gaps in the trace, and the risk for misinterpreting the maternal physiological parameter as the fetal physiological parameter can be reduced further.

5 It is another object of the invention to provide a fetal monitoring system, comprising at least two transducer units, at least one transducer provided for taking up physiological parameters and converting them into corresponding signals, at least a first signal processing unit provided to process signals, and at least one acceleration sensor provided for converting mechanical acceleration of a maternal abdomen into a corresponding
10 acceleration signal, wherein the at least one acceleration sensor is different from the at least one transducer, wherein the at least one acceleration sensor, in at least one operating mode, is rigidly mounted inside a housing of one of the at least two transducer units, and wherein the first signal processing unit is provided to evaluate the acceleration signal regarding at least one out of frequency, amplitude, and signal pattern to derive an acceleration signal
15 corresponding to at least one maternal physiological parameter.

An additional signal from an independent source can be obtained from the at least one acceleration sensor that allows for confirmation of physiological data and thus, for prevention of mistakes. The fetal monitoring systems may provide a reduced risk of misinterpreting the maternal physiological parameter, while maintaining operating comfort to
20 caregivers and ease to the child-bearing or birth-giving mother, as the maternal physiological parameter can be determined in a reliable and robust manner without employing additional sensors, electrodes, or the like.

Preferably, the first signal processing unit may reside in the housing of the one of the transducer units the acceleration sensor is rigidly mounted in, and may be designed to
25 receive the acceleration signal as an input signal. Alternatively, a second signal processing unit may be located in the housing of the one of the transducer units the acceleration sensor is rigidly mounted in, that may be assigned exclusively for evaluating the acceleration signal.

A continuous real-time monitoring can be obtained by furnishing the fetal monitoring system with a signal selector unit that is provided for selecting one out of the
30 transducer signals and the accelerator signal, based on an evaluation of at least one out of signal history and signal quality. This may also allow for an unambiguous attribution of the selected signal to the at least one maternal physiological parameter.

In a preferred embodiment, the signal selector unit comprises a software module that is provided for carrying out the steps of determining and tracking the cross-

channel verification and the activating of the alert, depending on the result of the cross-channel verification, and/or the step of selecting one out of the transducer signals and the accelerator signal. The steps are converted into a program code that is implementable in and executable by the fetal monitoring system. Thereby, a flexible adjustment, easy portability of the method and method parameters and a uniformity of products may readily be attainable.

The fetal monitoring system may further comprise a cross-channel verification unit provided for determining a cross-channel verification between traces of at least two of the signals in an at least partially continuous time interval. Thereby, a risk of misinterpreting the maternal physiological parameter as a fetal physiological parameter may be highly reducible.

In a preferred embodiment, the at least one acceleration sensor is designed as a micro-electromechanical system (MEMS). Thus, a robust and reliable solution for an acceleration sensor can be provided, which is rigidly mountable inside the housing of one of the at least two transducers in an easy manner.

Preferably, the at least one acceleration sensor is provided for converting mechanical acceleration into corresponding acceleration signals in three substantially orthogonal directions, by which a complete coverage of monitoring physiological parameters for all potential relative arrangements of the transducers of the fetal monitoring system and the subject may be achieved.

It is another object of the invention to provide a transducer unit for use in a fetal monitoring system. The transducer unit comprises at least one transducer provided for taking up physiological parameters and converting them into a corresponding signal, a housing that at least partially encompasses the transducer, and at least one acceleration sensor provided for converting mechanical acceleration into a corresponding acceleration signal, wherein the at least one acceleration sensor, in at least one operating mode, is rigidly mounted inside the housing, so that no additional external cabling is required.

BRIEF DESCRIPTION OF THE DRAWINGS

These and other aspects of the invention will be apparent from and elucidated with reference to the embodiments described hereinafter. Such embodiment does not necessarily represent the full scope of the invention, however, and reference is made therefore to the claims and herein for interpreting the scope of the invention.

In the drawings:

Fig. 1 shows a schematic plan view of two transducer units of a fetal monitoring system arranged in preparation of a state of operation at a mother prior to birth, and

5 Fig. 2 illustrates a schematic functional diagram of the fetal monitoring system pursuant to Fig. 1.

DETAILED DESCRIPTION OF EMBODIMENTS

Fig. 1 shows a schematic plan view of a fetal monitoring system 10 comprising two transducer units 16, 18 arranged in preparation of a state of operation at a mother 12 prior to birth. The two transducer units 16, 18 are designed for being attached to the mother's abdomen 14 with a belt (not shown).

The first transducer unit 16 comprises a housing 20 that partially encompasses a transducer 24 designed as a tocodynamometer having a flat area that is in contact with the abdomen 14. The tocodynamometer is provided for taking up a first maternal physiological parameter, namely a uterine pressure, which is converted by the tocodynamometer into a corresponding uterine pressure signal. Further, the first transducer unit 16 comprises another transducer 26 that is designed as an optical sensor which is integrated in the first transducer unit 16 at a lower outer surface of the housing 20. The optical transducer 26 is therefore also in contact with the abdomen 14. It uses an optical method to detect a pulsation of dermal blood vessels to derive a maternal heart rate signal MHR1. The pulsation in the abdominal skin is extremely weak, and the optical transducer 26, although having a number of advantages in other regards, is very susceptible to movements between transducer 26 and skin, which are caused by movements of the mother 12 or even by her coughing or laughing. This might result in gaps in a trace of the maternal heart rate MHR1.

The second transducer unit 18 comprises another housing 22 that partially encompasses a transducer 28 designed as an ultrasonic Doppler sensor, which is provided for taking up another physiological parameter, namely a fetal heart rate FHR. As mentioned in the introduction, a signal from the ultrasonic Doppler sensor that is intended to correspond to the fetal heart rate FHR might be affected by reflections from maternal vessels like the aorta or other abdominal vessels if not correctly adjusted or by a shift of a position of the unborn.

The first transducer unit 16 and the second transducer unit 18 each comprise an acceleration sensor 30, 32 that is different from the transducers 24, 26, 28 of the respective transducer unit 16, 18. In a state of operation, each one of the acceleration sensors 30, 32,

which is provided for converting mechanical acceleration of the maternal abdomen 14 into a corresponding acceleration signal, is rigidly mounted inside the housing 20, 22 of the respective transducer unit 16, 18.

5 The acceleration sensor 32 of the second transducer unit 18 is insensitive to any material between the sensor and skin like water or an acoustic coupling gel, which is required for the ultrasonic Doppler sensor to work properly. Thus, a usage of the ultrasonic Doppler sensor is not restricted by the acceleration sensor 32 in any way.

Each of the acceleration sensors 30, 32 is designed as a micro-electro-mechanical system (MEMS) of a type based on the cantilever beam and proof mass-principle.
10 This type of sensor is well known to the one of skills in the art and shall therefore not be described in further detail herein. The acceleration sensors 30, 32 are provided for converting mechanical acceleration into corresponding acceleration signals in three orthogonal directions, so that movements of the maternal abdomen 14 in any direction can be detected. As the transducer units 16, 18 are located at different positions at the abdomen 14 and with
15 different relative orientation with regard to the abdomen 14, both acceleration sensors 30, 32 will acquire slightly different and independent signals.

Each of the transducers 24, 26, 28 and each of the acceleration sensors 30, 32 have a signal processing unit 34 assigned to it that is provided to process a signal that is generated by the transducers 24, 26, 28 and acceleration sensors 30, 32, respectively, in
20 response to the physiological parameter.

The signal processing units 34 of each of the acceleration sensors 30, 32 are provided to evaluate the acceleration signal regarding at least one out of frequency, amplitude, and signal pattern to derive an acceleration signal corresponding to at least one maternal physiological parameter, as will be explained in the following.

25 A schematic functional diagram of the fetal monitoring system 10 is illustrated in Fig. 2. The two transducer units 16, 18 provide processed signals to a signal monitoring unit 36 via cabling or, alternatively, via a wireless connection.

The signal monitoring unit 36 of the fetal monitoring system 10 provides several options for displaying processed signals, as is commonly known. Further, the signal
30 monitoring unit 36 comprises a signal selector unit 38 the function of which will be explained later on. The signal selector unit 38 is provided to carry out specific steps of a method for determining at least one maternal physiological parameter out of a heart rate and a breathing rate. To this end, the signal selector unit 38 comprises a software module 40 provided for

carrying out these specific steps, wherein the steps are converted into a program code that is implemented in and executed by the signal selector unit 38 in the operational state.

Moreover, the fetal monitoring system 10 comprises a cross-channel verification unit 42 that is provided for determining a cross-channel verification between traces of two of the signals continuously over time. One of the two signals is the maternal heart rate signal MHR1, MHR2, MHR3 derived from any one of the acceleration sensors 30, 32 and the optical transducer 26. The other one of the two signals is the fetal heart rate FHR taken up by the transducer 28 designed as an ultrasonic Doppler sensor. In general, more than one ultrasonic Doppler sensor transducer could be employed for fetal monitoring, for instance in case of a multiple birth. Then, another cross-channel verification between the maternal heart rate signal MHR1, MHR2, MHR and a second fetal heart rate taken up by an additional ultrasonic Doppler sensor transducer would also be determined continuously over time.

Once the fetal monitoring system 10 is arranged as shown in Fig. 1 and put to operation, the transducers 24, 26, 28 and acceleration sensors 30, 32 provide their corresponding signals. The signal processing units 34 assigned to each one the acceleration sensors 30, 32 comprise means for evaluating the acceleration signals regarding at least one out of frequency, amplitude, and signal pattern to derive an acceleration signal corresponding to the at least one maternal physiological parameter, namely a maternal heart rate MHR2, MHR3.

The maternal heart rate MHR1, MHR2, MHR3 derived from any one of the acceleration sensors 30, 32 and the optical transducer 26 and the fetal heart rate FHR derived from the signal of the ultrasonic Doppler sensor are fed to the cross-channel verification unit 42 at a sample rate of the assigned signal processing units 34. The signal that is meant to represent the maternal heart rate MHR1, MHR2, MHR3 at the best is selected by the signal selector unit 38 based on multiple parameters like logical considerations, heart rate history, signal quality or other information. The cross-channel verification unit 42 compares a frequency of the selected maternal heart rate signal MHR1, MHR2, MHR3 and a fetal heart rate FHR signal from the ultrasonic Doppler sensor, and tracks a result over time. A pre-determined threshold for a difference in frequency is stored in a memory that the cross-channel verification unit 42 has access to. As long as the determined difference in frequency is larger than this pre-determined threshold, the signal selected by the signal selector unit 38 represents the correct maternal heart rate MHR1, MHR2, MHR3. Once the determined difference in frequency is smaller than the pre-determined threshold, the cross-channel

verification unit 42 activates an alert signal 44 to indicate that the ultrasonic Doppler sensor signal might be affected by a maternal pulse activity. In response to the alert signal 44, a caregiver can adjust a position of the ultrasonic Doppler sensor at the maternal abdomen 14, so as the signal of the ultrasonic Doppler sensor to correctly correspond to the fetal heart rate FHR again. By that, a reliability and robustness of the fetal monitoring system 10 is significantly increased and the risk of intrapartum fetal mortality is reduced.

While the invention has been illustrated and described in detail in the drawings and foregoing description, such illustration and description are to be considered illustrative or exemplary and not restrictive; the invention is not limited to the disclosed embodiments.

10 Other variations to the disclosed embodiments can be understood and effected by those skilled in the art in practicing the claimed invention, from a study of the drawings, the disclosure, and the appended claims. In the claims, the word "comprising" does not exclude other elements or steps, and the indefinite article "a" or "an" does not exclude a plurality. The mere fact that certain measures are recited in mutually different dependent claims does not
15 indicate that a combination of these measures cannot be used to advantage. Any reference signs in the claims should not be construed as limiting the scope.

REFERENCE SYMBOL LIST

10	fetal monitoring system
12	mother
14	abdomen
16	transducer unit
18	transducer unit
20	housing
22	housing
24	transducer
26	transducer
28	transducer
30	acceleration sensor
32	acceleration sensor
34	signal processing unit
36	signal monitoring unit
38	signal selector unit
40	software module
42	cross-channel verification unit
44	alert signal
D	display
MHR1	maternal heart rate signal
MHR2	maternal heart rate signal
MHR3	maternal heart rate signal
FHR	fetal heart rate signal

CLAIMS:

1. A method for determining at least one maternal physiological parameter out of a heart rate and a breathing rate, comprising the following steps:
 - (a) attaching at least two transducers units (16, 18) of a fetal monitoring system (10) to a maternal abdomen (14), the fetal monitoring system (10) further comprising
5 at least one transducer (24, 26, 28) provided for taking up physiological parameters and converting them into corresponding signals;
at least one signal processing unit (34) provided to process signals;
at least one acceleration sensor (30, 32) provided for converting mechanical acceleration at the maternal abdomen (14) into a corresponding acceleration signal, wherein
10 the at least one acceleration sensor (30, 32) is different from the at least one transducer (24, 26, 28), and wherein the at least one acceleration sensor (30, 32), in at least one operating mode, is rigidly mounted inside a housing (20, 22) that at least partially encompasses the at least one transducer (24, 26, 28);
 - (b) evaluating the acceleration signal regarding at least one out of frequency,
15 amplitude, and signal pattern to derive an acceleration signal corresponding to the at least one maternal physiological parameter.
2. The method as claimed in claim 1, further comprising the steps of
 - (c) determining and tracking a cross-channel verification between the acceleration
20 signal and at least one signal of the at least one transducer (24, 26, 28) corresponding to a fetal heart rate (FHR); and
 - (d) depending on a result of the cross-channel verification, activating an alert signal (44).
- 25 3. The method as claimed in claim 1, further comprising the step of
 - (c2) selecting one out of the transducer signals and the accelerator signal, based on an evaluation of at least one out of signal history and signal quality.

4. A fetal monitoring system (10), comprising:
at least two transducers units (16, 18), at least one transducer (24, 26, 28)
provided for taking up physiological parameters and converting them into corresponding
signals;
- 5 at least a first signal processing unit (34) provided to process signals;
at least one acceleration sensor (30, 32) provided for converting mechanical
acceleration of a maternal abdomen (14) into a corresponding acceleration signal,
wherein the at least one acceleration sensor (30, 32) is different from the at least one
transducer (24, 26, 28),
- 10 wherein the at least one acceleration sensor (30, 32), in at least one operating mode, is rigidly
mounted inside a housing (20, 22) of one of the at least two transducer units (16, 18); and
wherein the first signal processing unit (34) is provided to evaluate the acceleration signal
regarding at least one out of frequency, amplitude, and signal pattern to derive an
acceleration signal corresponding to at least one maternal physiological parameter.
- 15
5. The fetal monitoring system (10) as claimed in claim 4, further comprising a
signal selector unit (38) that is provided to carry out step (c2) of claim 3.
6. The fetal monitoring system (10) as claimed in claim 4 or 5, further
20 comprising a cross-channel verification unit (42) provided for determining a cross-
verification between traces of at least two of the signals in an at least partially continuous
time interval.
7. The fetal monitoring system (10) as claimed in any of the claims 4 to 6,
25 wherein the at least one acceleration sensor (30, 32) is designed as a micro-electromechanical
system.
8. The fetal monitoring system (10) as claimed in one of claim 4 to 7, wherein
30 the at least one acceleration sensor (30, 32) is provided for converting mechanical
acceleration into corresponding acceleration signals in three substantially orthogonal
directions.
9. A software module (40) provided for carrying out step (c) and (d) of claim 2
and/or step (c2) of claim 3, wherein the steps are converted into a program code that is

implementable in and executable by the fetal monitoring system (10) as claimed in any of the claims 4 to 8.

10. A transducer unit (16, 18) for use in a fetal monitoring system (10) as claimed
5 in any of the claims 4 to 8, comprising
- at least one transducer (24, 26, 28) provided for taking up physiological parameters and converting them into a corresponding signal;
 - a housing (20, 22) that at least partially encompasses the transducer (24, 26, 28);
 - 10 at least one acceleration sensor (30, 32) provided for converting mechanical acceleration into a corresponding acceleration signal, wherein
 - the at least one acceleration sensor (30, 32), in at least one operating mode, is rigidly mounted inside the housing (20, 22).

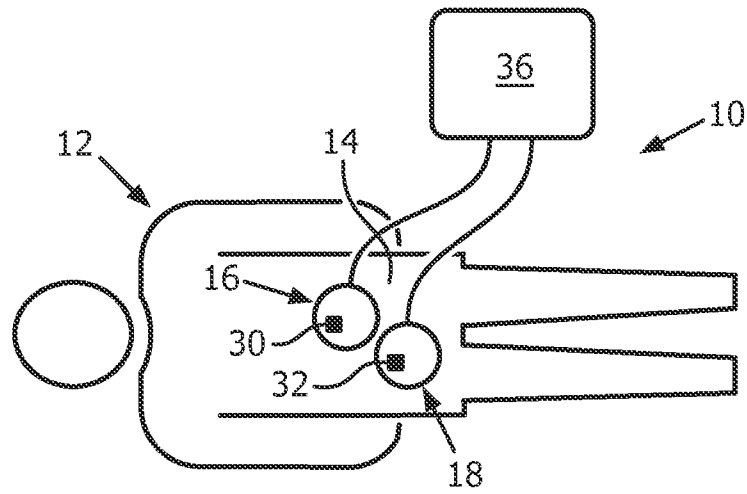

FIG. 1

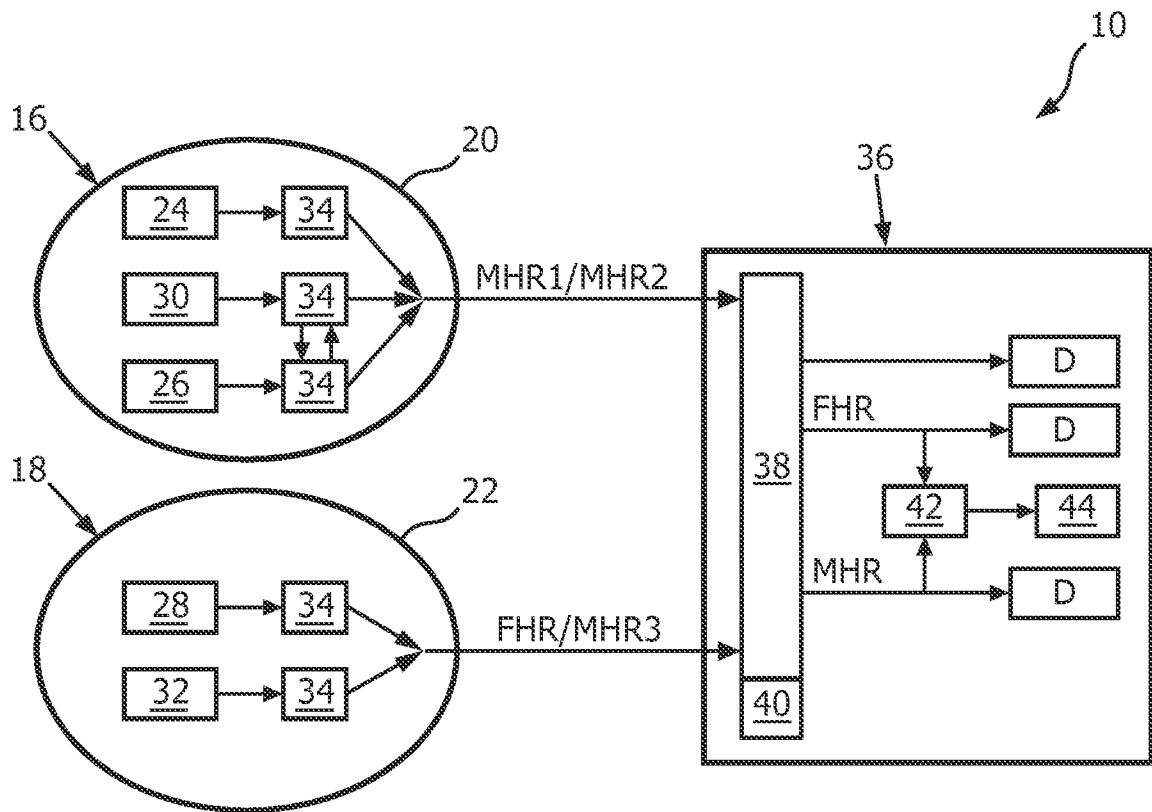

FIG. 2

INTERNATIONAL SEARCH REPORT

International application No
PCT/IB2013/055420

A. CLASSIFICATION OF SUBJECT MATTER
 INV. A61B5/00 A61B5/024 A61B5/0245 A61B5/113 A61B5/0444
 A61B8/08 A61B8/02
 ADD.
 According to International Patent Classification (IPC) or to both national classification and IPC

B. FIELDS SEARCHED
 Minimum documentation searched (classification system followed by classification symbols)
 A61B

Documentation searched other than minimum documentation to the extent that such documents are included in the fields searched

Electronic data base consulted during the international search (name of data base and, where practicable, search terms used)
 EPO-Internal, WPI Data, COMPENDEX, EMBASE, INSPEC

C. DOCUMENTS CONSIDERED TO BE RELEVANT

Category*	Citation of document, with indication, where appropriate, of the relevant passages	Relevant to claim No.
X	GB 2 471 667 A (MONICA HEALTHCARE LTD [GB]) 12 January 2011 (2011-01-12) abstract page 8, line 22 - page 22, line 11; figures 1,3,6,9	1-10
A	----- WO 99/05963 A1 (GENESIS TECHNOLOGIES INC [US]) 11 February 1999 (1999-02-11) abstract page 16, line 28 - page 17, line 18; figure 7	1-10
A	----- US 4 781 200 A (BAKER DONALD A [US]) 1 November 1988 (1988-11-01) abstract column 4, line 21 - column 6, line 40; figures 1,2,5 ----- -/--	1-10

Further documents are listed in the continuation of Box C.

See patent family annex.

* Special categories of cited documents :

- "A" document defining the general state of the art which is not considered to be of particular relevance
- "E" earlier application or patent but published on or after the international filing date
- "L" document which may throw doubts on priority claim(s) or which is cited to establish the publication date of another citation or other special reason (as specified)
- "O" document referring to an oral disclosure, use, exhibition or other means
- "P" document published prior to the international filing date but later than the priority date claimed

- "T" later document published after the international filing date or priority date and not in conflict with the application but cited to understand the principle or theory underlying the invention
- "X" document of particular relevance; the claimed invention cannot be considered novel or cannot be considered to involve an inventive step when the document is taken alone
- "Y" document of particular relevance; the claimed invention cannot be considered to involve an inventive step when the document is combined with one or more other such documents, such combination being obvious to a person skilled in the art
- "&" document member of the same patent family

Date of the actual completion of the international search 8 November 2013	Date of mailing of the international search report 04/12/2013
Name and mailing address of the ISA/ European Patent Office, P.B. 5818 Patentlaan 2 NL - 2280 HV Rijswijk Tel. (+31-70) 340-2040, Fax: (+31-70) 340-3016	Authorized officer Juárez Colera, M

INTERNATIONAL SEARCH REPORT

International application No
PCT/IB2013/055420

C(Continuation). DOCUMENTS CONSIDERED TO BE RELEVANT

Category*	Citation of document, with indication, where appropriate, of the relevant passages	Relevant to claim No.
A	WO 2012/061827 A2 (WEST WIRELESS HEALTH INST [US]; ROHAM MASOUD [US]; SALDIVAR ENRIQUE [U] 10 May 2012 (2012-05-10) the whole document -----	1-10

INTERNATIONAL SEARCH REPORT

Information on patent family members

International application No PCT/IB2013/055420

Patent document cited in search report	Publication date	Patent family member(s)	Publication date
GB 2471667	A	12-01-2011	EP 2451345 A2 16-05-2012 GB 2471667 A 12-01-2011 JP 2013505032 A 14-02-2013 US 2012150010 A1 14-06-2012 WO 2011004147 A2 13-01-2011
WO 9905963	A1	11-02-1999	AU 8762198 A 22-02-1999 US 6115624 A 05-09-2000 WO 9905963 A1 11-02-1999
US 4781200	A	01-11-1988	NONE
WO 2012061827	A2	10-05-2012	AU 2011323102 A1 23-05-2013 CA 2816894 A1 10-05-2012 EP 2635191 A2 11-09-2013 US 2012232398 A1 13-09-2012 WO 2012061827 A2 10-05-2012

专利名称(译)	用于改善母亲心率的确定的方法和对其的胎儿监测系统		
公开(公告)号	EP2872034A1	公开(公告)日	2015-05-20
申请号	EP2013765464	申请日	2013-07-02
[标]申请(专利权)人(译)	皇家飞利浦电子股份有限公司		
申请(专利权)人(译)	皇家飞利浦N.V. PHILIPS GMBH		
当前申请(专利权)人(译)	皇家飞利浦N.V. PHILIPS GMBH		
[标]发明人	REUTER STEFAN BENJAMIN WOHLSCHLAGER MARKUS GEYWITZ HANSJOERG		
发明人	REUTER, STEFAN BENJAMIN WOHLSCHLAGER, MARKUS GEYWITZ, HANSJOERG		
IPC分类号	A61B5/00 A61B5/024 A61B5/0245 A61B5/113 A61B5/0444 A61B8/08 A61B8/02		
CPC分类号	A61B5/0205 A61B5/1118 A61B8/02 A61B8/0866 A61B5/0059 A61B5/02411 A61B5/02455 A61B5/033 A61B5/0444 A61B5/113 A61B8/488 A61B5/11 A61B8/5223		
代理机构(译)	STEFFEN, THOMAS		
优先权	61/670648 2012-07-12 US		
外部链接	Espacenet		

摘要(译)

一种用于从心率和呼吸速率中确定至少一个母体生理参数的方法，包括以下步骤：(a) 将胎儿监测系统(10)的至少两个换能器单元(16,18)附接到母体腹部(14)；(b) 评估关于频率，幅度和信号模式中的至少一个的加速度信号，以导出对应于至少一个母体生理参数的加速度信号；胎儿监测系统(10)，包括至少两个换能器单元(16,18)，至少一个用于获取生理参数的换能器(24,26,28)，至少第一信号处理单元(34)，和至少一个加速度传感器(30,32)与前述至少两个换能器(24,26,28)不同，其中所述至少一个加速度传感器(30,32)在至少一个运行模式中刚性地安装在一个内部。所述至少两个换能器单元(16,18)之一的壳体(20,22)；并且其中提供第一信号处理单元(34)以评估关于频率，幅度和信号模式中的至少一个的加速度信号，以导出对应于至少一个母体生理参数的加速度信号；和用于胎儿监测系统(10)的换能器单元(16,18)。