

(19) World Intellectual Property Organization
International Bureau



(43) International Publication Date
23 February 2012 (23.02.2012)

(10) International Publication Number
WO 2012/024577 A2

- (51) **International Patent Classification:**
A61B 5/0402 (2006.01)
- (21) **International Application Number:**
PCT/US2011/048403
- (22) **International Filing Date:**
19 August 2011 (19.08.2011)
- (25) **Filing Language:** English
- (26) **Publication Language:** English
- (30) **Priority Data:**
61/375,442 20 August 2010 (20.08.2010) US
- (71) **Applicant (for all designated States except US):** C.R. BARD, INC. [US/US]; 730 Central Avenue, Murray Hill, NJ 07974 (US).
- (72) **Inventors; and**
- (75) **Inventors/Applicants (for US only):** POWERS, Kelly, B. [US/US]; 8 North Foxhill Road, North Salt Lake, UT 84054 (US). BEASLEY, Jim, C. [US/US]; 7339 North 3rd Avenue, Phoenix, AZ 85021 (US).
- (74) **Agent:** WIGHT, Todd, W.; Rutan & Tucker LLP, 611 Anton Boulevard, Suite 1400, Costa Mesa, CA 92626 (US).
- (81) **Designated States (unless otherwise indicated, for every kind of national protection available):** AE, AG, AL, AM,

AO, AT, AU, AZ, BA, BB, BG, BH, BR, BW, BY, BZ, CA, CH, CL, CN, CO, CR, CU, CZ, DE, DK, DM, DO, DZ, EC, EE, EG, ES, FI, GB, GD, GE, GH, GM, GT, HN, HR, HU, ID, IL, IN, IS, JP, KE, KG, KM, KN, KP, KR, KZ, LA, LC, LK, LR, LS, LT, LU, LY, MA, MD, ME, MG, MK, MN, MW, MX, MY, NA, NG, NI, NO, NZ, OM, PE, PG, PH, PL, PT, QA, RO, RS, RU, SC, SD, SE, SG, SK, SL, SM, ST, SV, SY, TH, TJ, TM, TN, TR, TT, TZ, UA, UG, US, UZ, VC, VN, ZA, ZM, ZW.

(84) **Designated States (unless otherwise indicated, for every kind of regional protection available):** ARIPO (BW, GH, GM, KE, LR, LS, MW, MZ, NA, SD, SL, SZ, TZ, UG, ZM, ZW), Eurasian (AM, AZ, BY, KG, KZ, MD, RU, TJ, TM), European (AL, AT, BE, BG, CH, CY, CZ, DE, DK, EE, ES, FI, FR, GB, GR, HR, HU, IE, IS, IT, LT, LU, LV, MC, MK, MT, NL, NO, PL, PT, RO, RS, SE, SI, SK, SM, TR), OAPI (BF, BJ, CF, CG, CI, CM, GA, GN, GQ, GW, ML, MR, NE, SN, TD, TG).

Declarations under Rule 4.17:

- as to applicant's entitlement to apply for and be granted a patent (Rule 4.17(ii))
- of inventorship (Rule 4.17(iv))

[Continued on next page]

(54) **Title:** RECONFIRMATION OF ECG-ASSISTED CATHETER TIP PLACEMENT

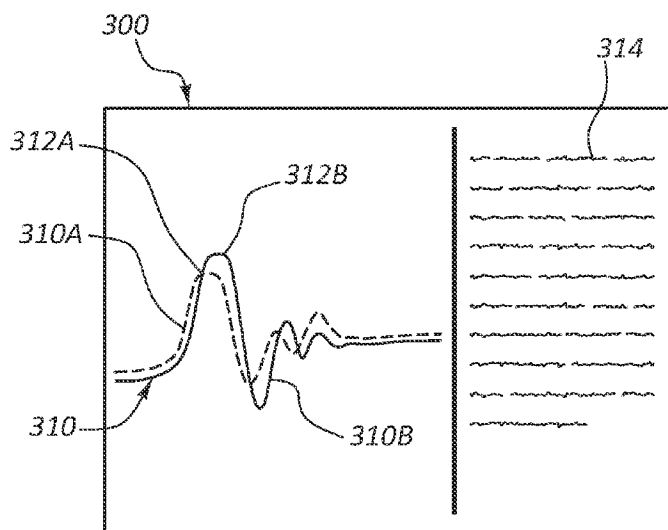

FIG. 7

(57) **Abstract:** Reconfirmation of the position of a catheter intravascularly placed with the assistance of ECG signals of the patient is disclosed, thus assisting in determination of subsequent catheter displacement within the patient vasculature. In one embodiment a method for reconfirming a position of an indwelling medical device within a body of a patient comprises first placing the medical device within the body of the patient using ECG signals of the patient. A first ECG signal profile relating to an initial position of the indwelling medical device after initial placement of the medical device is stored. A second ECG signal profile relating to the position of the indwelling medical device at a time subsequent to initial placement of the medical device is then acquired. The first ECG signal profile is compared with the second ECG signal profile to determine whether displacement of the indwelling medical device has occurred.

WO 2012/024577 A2

Published:

- *without international search report and to be republished upon receipt of that report (Rule 48.2(g))*

RECONFIRMATION OF ECG-ASSISTED CATHETER TIP PLACEMENT**CROSS-REFERENCE TO RELATED APPLICATIONS**

[0001] This application claims the benefit of U.S. Provisional Patent Application No. 61/375,442, filed August 20, 2010, and entitled “System for Reconfirmation of ECG-Assisted Catheter Tip Placement,” which is incorporated herein by reference in its entirety.

BRIEF SUMMARY

[0002] Briefly summarized, embodiments of the present invention are directed to reconfirmation of a position of a catheter or other indwelling device that has been placed with the assistance of ECG signals of the patient. The system and methods described herein enable a clinician to confirm whether the distal tip of the indwelling catheter remains positioned in the same location as when the catheter was initially placed. Should the tip be found to have migrated to another position, steps can be taken to return it to its proper position.

[0003] In one embodiment a method for reconfirming a position of an indwelling medical device within a body of a patient comprises first placing the medical device within the body of the patient using ECG signals of the patient. A first ECG signal profile relating to an initial position of the indwelling medical device after initial placement of the medical device is complete is stored. A second ECG signal profile relating to a position of the indwelling medical device at a time subsequent to initial placement of the medical device is then acquired. The first ECG signal profile is compared with the second ECG signal profile to determine whether displacement of the indwelling medical device has occurred after initial placement of the medical device. If displacement has occurred, the clinician can take the necessary steps to reposition the catheter as needed.

[0004] These and other features of embodiments of the present invention will become more fully apparent from the following description and appended claims, or may be learned by the practice of embodiments of the invention as set forth hereinafter.

BRIEF DESCRIPTION OF THE DRAWINGS

[0005] A more particular description of the present disclosure will be rendered by reference to specific embodiments thereof that are illustrated in the appended drawings. It is

appreciated that these drawings depict only typical embodiments of the invention and are therefore not to be considered limiting of its scope. Example embodiments of the invention will be described and explained with additional specificity and detail through the use of the accompanying drawings in which:

[0006] FIG. 1 is a block diagram depicting various elements of a system for intravascular placement of a catheter, according to one example embodiment of the present invention;

[0007] FIG. 2 is a simplified view of a patient and a catheter being inserted therein with assistance of the system of FIG. 1;

[0008] FIG. 3 is a partial cutaway view of a conductive pathway configuration within the catheter of FIG. 2 in accordance with one embodiment;

[0009] FIG. 4 is a perspective view of a card reader/encoder system for use in accordance with one embodiment;

[00010] FIG. 5 is a top view of a catheter bifurcation including an RFID chip in accordance with one embodiment;

[00011] FIG. 6 is a simplified top view of an RFID reader/encoder; and

[00012] FIG. 7 is a screenshot of the display of the system of FIG. 2 showing a plurality of ECG waveforms during use of the system in confirming a position of a catheter, in accordance with one embodiment.

DETAILED DESCRIPTION OF SELECTED EMBODIMENTS

[00013] Reference will now be made to figures wherein like structures will be provided with like reference designations. It is understood that the drawings are diagrammatic and schematic representations of exemplary embodiments of the present invention, and are neither limiting nor necessarily drawn to scale.

[00014] For clarity it is to be understood that the word “proximal” refers to a direction relatively closer to a clinician using the device to be described herein, while the word “distal” refers to a direction relatively further from the clinician. For example, the end of a catheter placed within the body of a patient is considered a distal end of the catheter, while the catheter end remaining outside the body is a proximal end of the catheter. Also, the words

“including,” “has,” and “having,” as used herein, including the claims, shall have the same meaning as the word “comprising.”

[00015] Embodiments of the present invention are generally directed to reconfirmation of a position of a catheter or other indwelling device that has been placed with the assistance of ECG signals of the patient. As is explained herein, the system and methods described herein particularly enable a clinician to confirm whether the distal tip of the indwelling catheter remains positioned in the same location as when the catheter was initially placed. Should the tip be found to have migrated to another position, steps can be taken to return it to its proper position.

[00016] Reference is first made to FIGS. 1 and 2, where one example of a catheter placement and monitoring system, generally designated at 10, is shown. The system 10 enables visualization of a subcutaneous vessel of a patient 70 via ultrasound imaging, followed by insertion, advancement, and final placement of a catheter 72 within the patient's vasculature via monitoring of ECG signals emitted by the SA node of the patient's heart. A simplified block diagram of hardware and other components of the system 10 is shown in FIG. 1, while FIG. 2 depicts the system and catheter 72 in relation to the patient 70. As shown, the system 10 in one embodiment generally includes a console 20 housing a display 30, an ultrasound probe 40, and a sensor unit 50 for placement on the chest of the patient 70.

[00017] In greater detail and as mentioned above, FIG. 2 shows the general relation of the components of the system 10 to a patient 70 during a procedure to place the catheter 72 into the patient vasculature through a skin insertion site 73. FIG. 2 shows that the catheter 72 generally includes a proximal portion 74 that remains exterior to the patient and a distal portion 76 that resides within the patient vasculature after placement is complete. The system 10 is employed to ultimately position a distal tip 76A of the catheter 72 in a desired position within the patient vasculature. In one embodiment, the desired position for the catheter distal tip 76A is proximate the patient's heart, such as in the lower one-third ($1/3^{\text{rd}}$) portion of the Superior Vena Cava (“SVC”). Of course, the system 10 can be employed to place the catheter distal tip in other locations. The catheter proximal portion 74 further includes a bifurcation 74A that provides fluid communication between the one or more lumens of the catheter 72 and one or more extension legs 74B extending proximally from the hub. Each extension leg 74B includes a luer connector 74C for attachment to suitable medical devices.

[00018] The console 20 houses various components necessary for operation of the system 10. A processor 22, including non-volatile memory such as EEPROM for instance, is included in the console 20 for controlling system function during operation of the system 10, thus acting as a control processor. A digital controller/analog interface 24 is also included with the console 20 and is in communication with both the processor 22 and other system components to govern interfacing between the ultrasound probe 40, sensor 50, and other system components.

[00019] The console 20 further includes ports 52 for connection with the sensor 50 and optional components 54 including a printer, storage media, keyboard, etc. The ports 52 in one embodiment are USB ports, though other port types or a combination of port types can be used for this and the other interfaces connections described herein. A power connection 56 is included with the console 20 to enable operable connection to an external power supply 58. An internal battery 60 can also be employed, either with or exclusive of an external power supply. Power management circuitry 59 is included with the digital controller/analog interface 24 of the console to regulate power use and distribution.

[00020] The display 30 of the system 10 in the present embodiment is integrated into the console 20 and is used to display information to the clinician during the catheter placement procedure, and as will be seen, during reconfirmation of catheter distal tip position in accordance with embodiments to be described below. Optionally, the display may be separate from the console. In one embodiment, a console button interface 32 and buttons included on the probe 40 can be used to control functionality of the system 10 during the catheter placement procedure. Thus, the single display 30 of the system console 20 can be employed for ultrasound guidance in accessing a patient's vasculature, ECG-based confirmation of catheter distal tip placement with respect to a node of the patient's heart, as well as subsequent confirmation of catheter distal tip position, as will be seen below. In one embodiment, the display 30 is an LCD device.

[00021] As mentioned above, the ultrasound probe 40 is employed in connection with ultrasound ("US")-based visualization of a subcutaneous vessel, such as a vein, in preparation for insertion of the catheter 72 into the vasculature. Such visualization gives real time ultrasound guidance for introducing the catheter into the vasculature of the patient (via the insertion site 73) and assists in reducing complications typically associated with such introduction, including inadvertent arterial puncture, hematoma, pneumothorax, etc.

[00022] The handheld probe 40 includes a head housing a piezoelectric array for producing ultrasonic pulses and for receiving echoes thereof after reflection by the patient's body when the head is placed against the patient's skin proximate the prospective insertion site 73. The probe 40 can further include a plurality of control buttons for controlling the system 10, thus eliminating the need for the clinician to reach out of the sterile field, which is established about the patient insertion site prior to catheter placement, to control system functionality.

[00023] As such, in one embodiment a clinician employs the ultrasound modality of the system 10 to determine a suitable insertion site and establish vascular access, such as with a needle or introducer, then with the catheter. The clinician can then seamlessly switch, via button pushes on the buttons included on the probe 40, to an ECG-based catheter tip guidance modality (described below), without having to reach out of the sterile field. In this way, the system 10 assists the clinician in guiding the distal tip of the catheter 72 through the vasculature toward an intended destination.

[00024] FIG. 1 shows that the probe 40 further includes a button and memory controller 42 for governing button and probe operation. The button and memory controller 42 can include non-volatile memory, such as EEPROM, in one embodiment. The button and memory controller 42 is in operable communication with a probe interface 44 of the console 20, which includes a piezo input/output component 44A for interfacing with the probe piezoelectric array and a button and memory input/output component 44B for interfacing with the button and memory controller 42.

[00025] As mentioned, the system 10 includes functionality wherein determination of the proximity of the catheter distal tip 76A relative to a sino-atrial ("SA") or other electrical impulse-emitting node of the heart of the patient 70 can be determined, thus providing enhanced ability to accurately place the catheter distal tip in a desired location proximate the node. Also referred to herein as "ECG" or "ECG-based tip confirmation," this modality of the system 10 enables detection of ECG signals from the SA node in order to place the catheter distal tip in a desired location within the patient vasculature. Note that the US and ECG modalities are seamlessly combined in the present system 10, and can be employed in concert or individually to assist in catheter placement. In addition, other modalities, such as magnetic element-based catheter tip location, can also be included in the system 10. In one embodiment, it is understood that the ECG modality as described herein can be included in a

stand-alone system without the inclusion of the US or other modalities. Thus, the environments in which the embodiments herein are described are understood as merely example environments and are not considered limiting of the present disclosure. Note also that other ECG-based guidance/monitoring systems can be employed in connection with the distal tip reconfirmation embodiments described further below.

[00026] FIGS. 1 and 2 show a stylet 130 removably predisposed within the lumen of the catheter 72 being inserted into the patient 70 via the insertion site 73. The stylet 130 includes a sensing component, i.e., an electrode proximate its distal end for sensing ECG signals produced by the SA node. The stylet 130 includes a tether 134 extending from its proximal end that operably connects to the sensor 50. In brief, the stylet tether 134 provides a conductive path that permits ECG signals detected by the ECG electrode included on a distal portion of the stylet 130 to be conveyed to the sensor 50 during catheter advancement.

[00027] Reference and ground ECG skin electrodes 138 attach to the skin surface of the patient 70 and are operably attached to the sensor 50 to enable the system to filter out high level electrical activity unrelated to the electrical activity of the SA node of the heart, thus enabling the ECG-based tip confirmation functionality. Together with the reference and ground signals received from the ECG skin electrodes 138 placed on the patient's skin, the ECG signals sensed by the stylet electrode are received by the sensor 50 positioned on the patient's chest or other designated component of the system 10. The sensor 50 and/or console processor 22 can process the ECG signal data to produce an electrocardiogram waveform on the display 30. In the case where the sensor 50 processes the ECG signal data, a processor is included therein to perform the intended functionality. If the console 20 processes the ECG signal data, the processor 22, controller 24, or other processor can be utilized in the console to process the data.

[00028] Thus, as the catheter 72 is advanced through the patient vasculature, the display 30 depicts an ECG electrocardiogram waveform produced as a result of patient heart's electrical activity as detected by the electrode of the stylet 130. In greater detail, the ECG electrical activity of the SA node, including a P-wave portion of the waveform, is detected by the electrode of the stylet 130 and forwarded to the sensor 50 and console 20. The ECG electrical activity is then processed for depiction on the display 30. A clinician placing the catheter can then observe the ECG data, including depiction of the P-wave, to determine

optimum placement of the distal tip 76A of the catheter 72, such as proximate the SA node in one embodiment.

[00029] Note that the ECG waveform and its P-wave change as the electrode of the stylet 130 is moved relative to the SA node of the patient's heart. For instance, the P-wave of the ECG waveform will generally increase in amplitude as the electrode approaches the SA node and will generally decrease as the electrode recedes from the SA node. As mentioned, in one embodiment the console 20 includes the electronic components, such as the processor 22, necessary to receive and process the ECG signals detected by the stylet electrode. In another embodiment, the sensor 50 can include the necessary electronic components to process the ECG signals. Further details regarding the catheter placement system described herein and its use can be found in U.S. Patent Application Publication No. 2010/0036227, filed September 10, 2009, and entitled "Apparatus and Display Methods Relating to Intravascular Placement of a Catheter," which is incorporated herein by reference in its entirety. Of course, it is appreciated that the ECG-based catheter placement system described above is but one example of an ECG monitor that can be used to practice the embodiments disclosed herein; indeed, other ECG-based monitoring and placement systems can also be employed.

[00030] Note that the electrode of the stylet 130 in the present embodiment includes a distal portion of the conductive stylet wire such that ECG signals are detected and transmitted via the stylet wire to the tether 134 and the sensor 50. It is noted, however, that an electrode used to detect intravascular ECG signals can be configured in many different ways. As such, "electrode" as used herein can generally refer to any structure that can be used to detect ECG signals from the heart of the patient. As will be seen, an electrode in other embodiments can include a portion of a column of conductive solution disposed in a lumen of the catheter, among other possible electrode configurations.

[00031] As described further above, monitoring of changes in the detected ECG signal emitted by the SA node as the stylet electrode(s) is advanced within the vasculature enables the clinician placing the catheter to determine when the distal tip of the catheter 72 is positioned as desired within the vasculature. Again, one example of a desirable catheter distal tip position includes placement thereof in the lower 1/3rd of the Superior Vena Cava ("SVC"). After placement of the catheter 72 is complete, the stylet 130 is removed from the lumen of the catheter 72 and the catheter is prepped for initial use. The ECG waveform

detected when the distal tip 76A of the catheter 72 is initially placed in its desired position within the patient vasculature is also referred to herein as the first ECG signal profile.

[00032] It is often desirable to re-confirm the position of the catheter distal tip 76A at a later time after initial placement of the catheter so as to ensure that no malposition or displacement of the distal tip has inadvertently occurred. In turn, this ensures that medicaments or other solutions delivered to the patient via the catheter are delivered to the desired region of the vasculature. The system 10 or other suitable ECG monitoring system can be employed in reconfirming proper catheter distal tip position post-placement.

[00033] In one embodiment, such reconfirmation of catheter distal tip placement can be achieved by measuring the ECG waveform – also referred to herein as a second ECG signal profile – detected at or near the distal tip of the in-place catheter via a suitably placed electrode, then comparing the second ECG profile with the first ECG profile taken when the catheter 72 was initially placed using the system 10.

[00034] In order to measure ECG signals at the indwelling catheter distal tip and thus acquire the second ECG profile, a suitable conductive path must be present in the catheter 72 to enable ECG signals with respect to the catheter distal tip to be detected and transmitted to the system 10 or other suitable ECG monitor. In one embodiment, a conductive wire temporarily disposed in the catheter is used as the conductive medium, with its distal end serving as an electrode for detection of ECG signals. The conductive wire can be inserted through one of the luer connectors 74C and its respective extension leg 74B, then distally through a lumen of the catheter 72. Knowing the length of the in-place catheter 72, the wire is advanced until its distal end is proximate to or co-terminal with the distal tip 76A of the catheter.

[00035] A proximal end of the conductive wire extending beyond the proximal end of the catheter 72 and out the extension leg 74B through which the wire extends is operably connected to the system 10 in a manner similar to that of the stylet 130 and tether 134 of FIG. 2. This configuration enables ECG signals emitted by the SA node, *i.e.*, the second ECG profile, to be detected at or near the distal end of the conductive wire and transmitted via the conductive wire to the system 10, thus informing the clinician as to ECG profile of the distal tip 76A of the catheter 72 in its current position.

[00036] As mentioned, the conductive wire configured as discussed immediately above is similar to the stylet 130 shown in FIG. 2. Indeed, in one embodiment the stylet 130 used for the initial catheter placement can be used again subsequent to the initial placement to reconfirm catheter distal tip location by inserting it into the lumen of the catheter 72 and operably connecting it to the system 10 via the tether 134 as shown in FIG. 2 so as to enable the second ECG profile of the catheter distal tip in its current location to be acquired. In addition, another suitable stylet or guidewire can be employed to provide the above-described conductive path from the catheter distal tip to the system.

[00037] FIG. 3 shows details of another configuration for providing a conductive path between an electrode at or near the indwelling catheter distal end 76A and the system 10 for tip position reconfirmation. In particular, the conductive path includes a conductive solution 200 disposed in the respective extension leg 74B and lumen of the catheter 72 so as to extend to the distal tip 76A thereof. The conductive solution 200 includes saline, or other biocompatible and electrically conductive solution. So configured, the conductive solution 200 serves as an electrode and a portion of a conductive path for detecting ECG signals at the distal tip 76A of the catheter 72. A cap 202 is connected to the luer connector 74C of the respective fluid-filled extension leg 74B.

[00038] In addition to the conductive solution 200, the conductive path of the embodiment of FIG. 3 further includes a conductive wire 208 that passes through the cap 202 and extends distally through the respective extension leg 74B such that a distal end 208B thereof is immersed in the conductive solution. A proximal portion of the conductive wire 208 terminating in a proximal end 208A extends from the cap 202. An alligator clip 210 or other suitable electrical connector is attached to the proximal portion of the conductive wire 208. The clip 210 is operably connected to a tether 234, which connects to the sensor 50 of the system 10, similar to the manner of connection of the tether 134 in FIG. 2, thus operably connecting the column of the conductive solution 200 disposed in the catheter 72 to the system and enabling ECG signals detected by the conductive solution to be transmitted to the system. In this way, the second ECG signal profile representing the position of the distal tip 76A of the catheter 72 within the vasculature can be acquired. In addition to those described in connection with FIGS. 2 and 3, note that other conductive path configurations can be employed in other embodiments. Thus, these conductive path solutions should be considered as non-limiting.

[00039] In order to compare the first ECG signal profile acquired at the time of initial catheter distal tip placement with a subsequent second ECG profile measured at the time of distal tip position reconfirmation, a storage component for storage of the first ECG signal profile at the time of initial placement is necessary. In one embodiment, this is accomplished by fitting the system 10 or other suitable ECG monitor system with a card reader/encoder 250, an example of which is shown in FIG. 4 as attached to the console 20. Thus, when the catheter 72 is initially placed using the system 10, a patient data card 254 can be encoded by the system 10 by swiping the card through the reader/encoder 250, which encodes and stores on a magnetic stripe 256 of the data card various data regarding the initial catheter placement, including the first ECG signal profile at time of initial placement. The card 254 is then given to the patient or otherwise safeguarded.

[00040] Later, when reconfirmation of the position of the distal tip 76A of the previously placed catheter 72 (FIG. 1) is desired, the catheter is operably connected to the system 10 in one of the configurations described above in connection with FIGS. 2, 3, or by another suitable manner so as to provide a conductive path from the distal tip 76A of the catheter to the system. The card 254, encoded at time of initial catheter placement is then swiped through the reader/encoder 250 of the system 10 so as to be read thereby. This provides to the system 10 the first ECG signal profile of the catheter distal tip position at time of initial placement. The first ECG signal profile, including for instance an ECG waveform as detected by an electrode at or near the distal end 76A of the catheter 72 at time of initial placement, can be depicted on the display 30 of the system console 20 (FIG. 1), or otherwise conveyed to the clinician.

[00041] A new ECG signal measurement, using an electrode disposed at or near the distal tip 76A of the catheter 72 and the suitable conductive path interconnecting the electrode with the system 10, is then taken to produce a second ECG signal profile relating to the current catheter distal tip position within the vasculature. The second ECVG signal profile can, like the first ECG signal profile, also be depicted on the display 30 of the system console 20. The two ECG signal profiles can be superimposed as ECG waveforms atop one another and compared in some suitable manner (*e.g.*, measurement of P-wave absolute voltage values) so as determine whether the distal tip 76A of the catheter 72 has been undesirably displaced. If so, proper procedures can be undertaken by the clinician to suitably re-position the catheter distal tip 76A. If it has not been displaced, the catheter 72 can be used as intended. Note that

the specific order of the process described above can vary in other embodiments. For instance, acquisition of the second ECG signal profile can take place before inputting the first ECG signal profile into the system, in one embodiment.

[00042] FIG. 5 shows another possible storage component for enabling storage and access to initial placement first ECG signal profile and other data, wherein an RFID chip 270 is embedded in a portion of the catheter 72 itself, such as the bifurcation 74A (*see also* FIG. 2). An RFID encoder/reader 274 including an antenna 280 and associated circuitry 282, as shown in FIG. 6, can be included with the system 10 or other suitable ECG monitor to enable the first ECG signal profile relating to the position of the catheter distal tip 76A at time of initial placement to be encoded and stored on the catheter RFID chip 270. In one embodiment, the RFID chip 270 is a field-programmable chip, including both read-only memory for unique identification of the chip itself, as well as non-volatile memory that is programmable by the RFID encoder/reader 274 to store the first ECG signal profile at time of initial placement.

[00043] In addition to the first ECG signal profile, other data can be stored on the RFID chip 270 (or the card 254 of FIG. 4 or other suitable storage component), including patient name, date and location of initial placement, final length of catheter after trimming, record of previous power injections, creatinine or other blood counts, etc. In one embodiment, the length of the portion of the PICC that remains external to the insertion site after placement is complete is stored. In another embodiment, web portal information can be stored to direct a user to a website where useful information or other assistance is provided. Note that the RFID chip 270 can be either active or passive. Note further that other storage components are possible for storing the first and/or second ECG signal profiles, including a memory location within the system 10 itself and remote offsite storage wherein the ECG signal monitor can access the profiles wirelessly, such as via WiFi or other suitable wireless protocol.

[00044] FIG. 7 shows one possible example of a screenshot 300 for depiction on the display 30 of the system 10 during reconfirmation of the catheter distal tip position, according to one embodiment. As shown, the screenshot 300 shows ECG waveforms 310, including a waveform 310A corresponding to the first ECG signal profile at time of initial catheter placement and a waveform 310B corresponding to the second ECG signal profile at time of reconfirmation of the distal tip placement, described above. The two waveforms

310A and 310B can be calibrated by the system 10 and superimposed atop one another in one embodiment so as to enable a comparison therebetween to be made. In one embodiment, for instance, a P-wave 312A of the initial waveform 310A can be compared with a P-wave 312B of the current waveform 310B so as to determine whether displacement of the catheter distal tip 76A with respect to the SA node has occurred.

[00045] The right side of the screenshot 300 also shows additional data 314 regarding the patient, catheter type, catheter length, etc. Of course, the ECG signal and other data depicted here can take one or more of many forms and formats. Indeed, the data content can vary according to desire or need, as appreciated by one skilled in the art. In one embodiment for instance, both the peak P-wave magnitude during initial catheter placement, as well as the P-wave magnitude after catheter pull-back for final distal tip positioning during initial placement, are stored for later comparison with similar magnitudes taken at time of tip reconfirmation.

[00046] Thus, according to one embodiment a method is disclosed for reconfirming a position of a catheter or other indwelling medical device within a body of a patient. The method includes placing the medical device within the body of the patient using ECG signals of the patient, then storing a first ECG signal profile that relates to an initial position of the indwelling medical device after initial placement of the medical device is complete. As mentioned, the first ECG signal profile can be stored on a patient card, an RFID chip, in system memory, writing down or printing the ECG signal data, or on another suitable storage component. The method further includes acquiring a second ECG signal profile relating to a position of the indwelling medical device at a time after initial placement of the medical device, and comparing the first ECG signal profile with the second ECG signal profile to determine whether displacement of the indwelling medical device has occurred after initial placement of the medical device. Note that comparing the profiles can be performed directly by a clinician observing the waveforms depicted on the console display 30, or automatically by suitable algorithms executable by the processor 22 of the console 20.

[00047] Embodiments of the invention may be embodied in other specific forms without departing from the spirit of the present disclosure. The described embodiments are to be considered in all respects only as illustrative, not restrictive. The scope of the embodiments is, therefore, indicated by the appended claims rather than by the foregoing description. All

changes that come within the meaning and range of equivalency of the claims are to be embraced within their scope.

What is claimed is:

CLAIMS

1. A method for reconfirming a position of an indwelling medical device within a body of a patient, the method comprising:
 - placing the medical device within the body of the patient using ECG signals of the patient;
 - storing a first ECG signal profile relating to an initial position of the indwelling medical device after initial placement of the medical device is complete;
 - acquiring a second ECG signal profile relating to a position of the indwelling medical device at a time subsequent to initial placement of the medical device; and
 - comparing the first ECG signal profile with the second ECG signal profile to determine whether displacement of the indwelling medical device has occurred after initial placement of the medical device.

2. The method for reconfirming as defined in claim 1, wherein the medical device includes a catheter and wherein displacement of the medical device is determined relative to a distal tip of the catheter.

3. The method for reconfirming as defined in claim 1, wherein storing the first ECG signal profile includes storing the first ECG signal profile on a component associated with the medical device or the patient.

4. The method for reconfirming as defined in claim 3, wherein storing the first ECG signal profile includes storing the first ECG signal profile on a card readable by a card reader.

5. The method for reconfirming as defined in claim 3, wherein storing the first ECG signal profile includes storing the first ECG signal profile on the medical device itself.

6. The method for reconfirming as defined in claim 5, wherein the medical device includes a catheter and wherein storing the first ECG profile includes storing the first ECG signal profile on an RFID chip included with the catheter.

7. The method for reconfirming as defined in claim 1, wherein storing the first ECG signal profile includes storing the first ECG signal profile remotely from the medical device.

8. The method for reconfirming as defined in claim 1, wherein storing the first ECG signal profile further includes forwarding ECG signals from an electrode associated with the medical device to an ECG monitor via a conductive path established between the electrode and the ECG monitor.

9. The method for reconfirming as defined in claim 8, wherein comparing the first ECG signal profile with the second ECG signal profile includes depicting the first and second ECG signal profiles as waveforms on a display of the ECG monitor.

10. The method for reconfirming as defined in claim 9, wherein comparing the first and second ECG signal profiles includes comparing P-wave components of the first and second ECG signal profiles.

11. The method for reconfirming as defined in claim 10, wherein storing the first ECG signal profile includes storing the first ECG signal profile in a memory of the ECG signal monitor.

12. A system for reconfirming the position of a catheter within a patient, the catheter being disposed in proximity to an ECG signal-producing node of the heart of the patient, the system comprising:

at least one electrode for acquiring a first ECG signal profile, the first ECG signal profile relating to an initial position of a distal tip of the catheter within the patient, the at least one electrode also for acquiring a second ECG signal profile relating to a subsequent position of the distal tip of the catheter within the patient;

a storage component for storing at least the first ECG signal profile; and

an ECG signal monitor that receives the first ECG signal profile from the storage component and also receives the second ECG signal profile, the ECG signal monitor conveying data relating to first and second ECG signal profiles so as to enable determination of whether the subsequent position of the distal tip of the catheter differs from the initial position.

13. The system for reconfirming as defined in claim 12, wherein the at least one electrode for acquiring the first ECG signal profile is included with the catheter within the body of the patient, and wherein the at least one electrode is operably connected to the ECG signal monitor by a conductive path.

14. The system for reconfirming as defined in claim 13, wherein the at least one electrode includes a stylet disposed within a lumen of the catheter, and wherein the conductive path includes a tether operably connected to the at least one electrode.

15. The system for reconfirming as defined in claim 12, wherein the at least one electrode and conductive path includes a conductive solution disposed within a lumen of the catheter.

16. The system for reconfirming as defined in claim 15, wherein a conductive wire is partially disposed in the conductive solution, the conductive wire extending from the catheter and operably connecting to the ECG signal monitor.

17. The system for reconfirming as defined in claim 12, wherein the storage component includes an RFID chip included in the catheter, and wherein the ECG signal monitor includes an RFID encoder/reader for encoding and reading the first ECG signal profile of the RFID chip.

18. The system for reconfirming as defined in claim 17, wherein the RFID chip is a field-programmable chip.

19. The system for reconfirming as defined in claim 12, wherein the storage component is remotely disposed with respect to the catheter.

20. The system for reconfirming as defined in claim 19, wherein the storage component includes a card including a programmable magnetic stripe, and wherein the ECG signal monitor includes a card encoder/reader.

21. The system for reconfirming as defined in claim 12, wherein the ECG signal monitor wirelessly receives the first ECG signal profile from a remote location.

22. The system for reconfirming as defined in claim 12, wherein at least one of the first and second ECG signal profiles includes data relating to at least one of a length of the portion of the catheter remaining external to the body of the patient after placement and a web portal where further information can be acquired.

23. The system for reconfirming as defined in claim 12, wherein the ECG signal monitor includes at least one electrode disposed internal to the patient and at least two electrodes for placement of the skin of the patient.

24. The system for reconfirming as defined in claim 12, wherein a first electrode is employed in acquiring the first ECG signal profile and a second electrode is employed in acquiring the second ECG signal profile.

25. A method for reconfirming a position of a distal tip of a catheter within a vasculature of a patient, the method comprising:

- placing a catheter within the vasculature of the patient using ECG signals of the patient;
- storing a first ECG signal profile relating to an initial position of the distal tip of the catheter after initial placement of the catheter is complete;
- acquiring a second ECG signal profile relating to a position of the distal tip of the catheter at a time after initial placement of the catheter; and
- comparing the first ECG signal profile with the second ECG signal profile to determine whether displacement of the catheter within the vasculature has occurred after initial placement of the catheter.

26. The method for reconfirming as defined in claim 25, wherein comparing the first and second ECG signal profiles includes visually observing first and second ECG waveforms detected by at least one electrode disposed within the patient.

27. The method for reconfirming as defined in claim 26, wherein comparing the first and second ECG signal profiles includes comparing P-wave components of the first and second ECG waveforms, the first and second ECG waveforms depicted in a superimposed fashion on a display of an ECG signal monitor.

28. The method for reconfirming as defined in claim 25, wherein comparing the first and second ECG signal profiles is performed automatically by an ECG signal monitor that receives the first and second ECG signal profiles.

29. The method for reconfirming as defined in claim 25, wherein storing the first ECG signal profile includes:

acquiring the first ECG signal profile via at least one intravascular electrode;

and

storing the first ECG signal profile on a storage component, the storage component encodable by an encoder included with an ECG monitor.

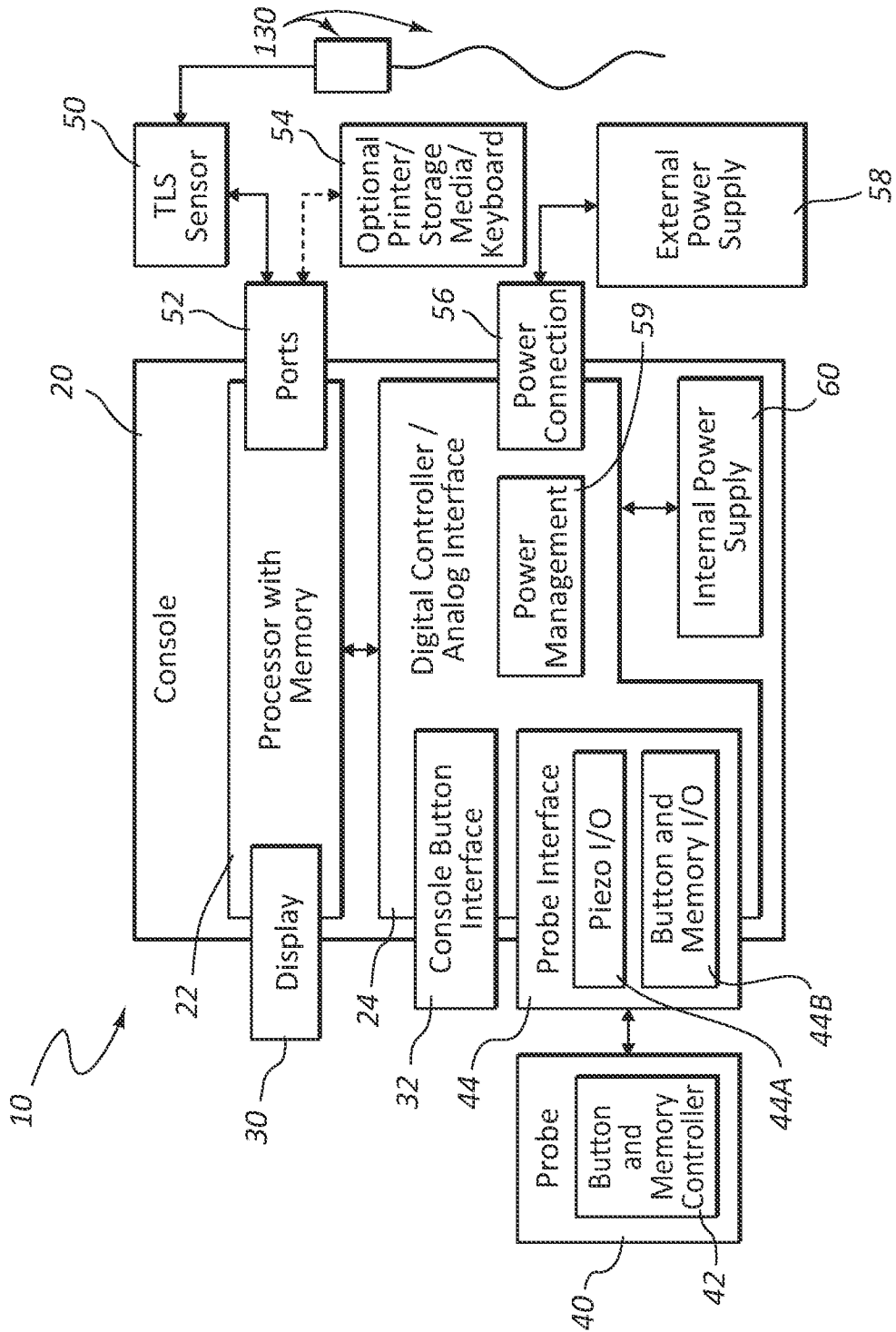

FIG. 1

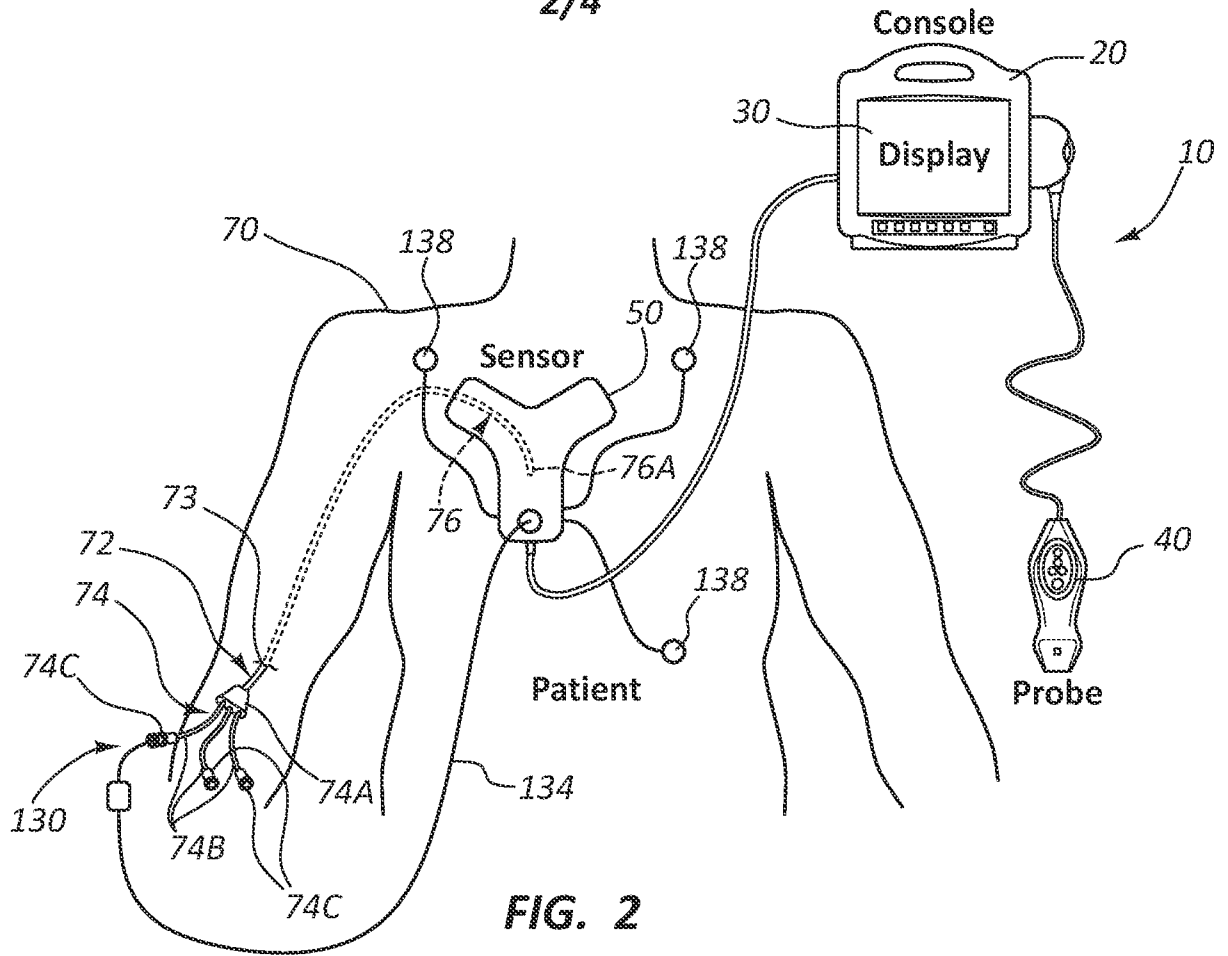

FIG. 2

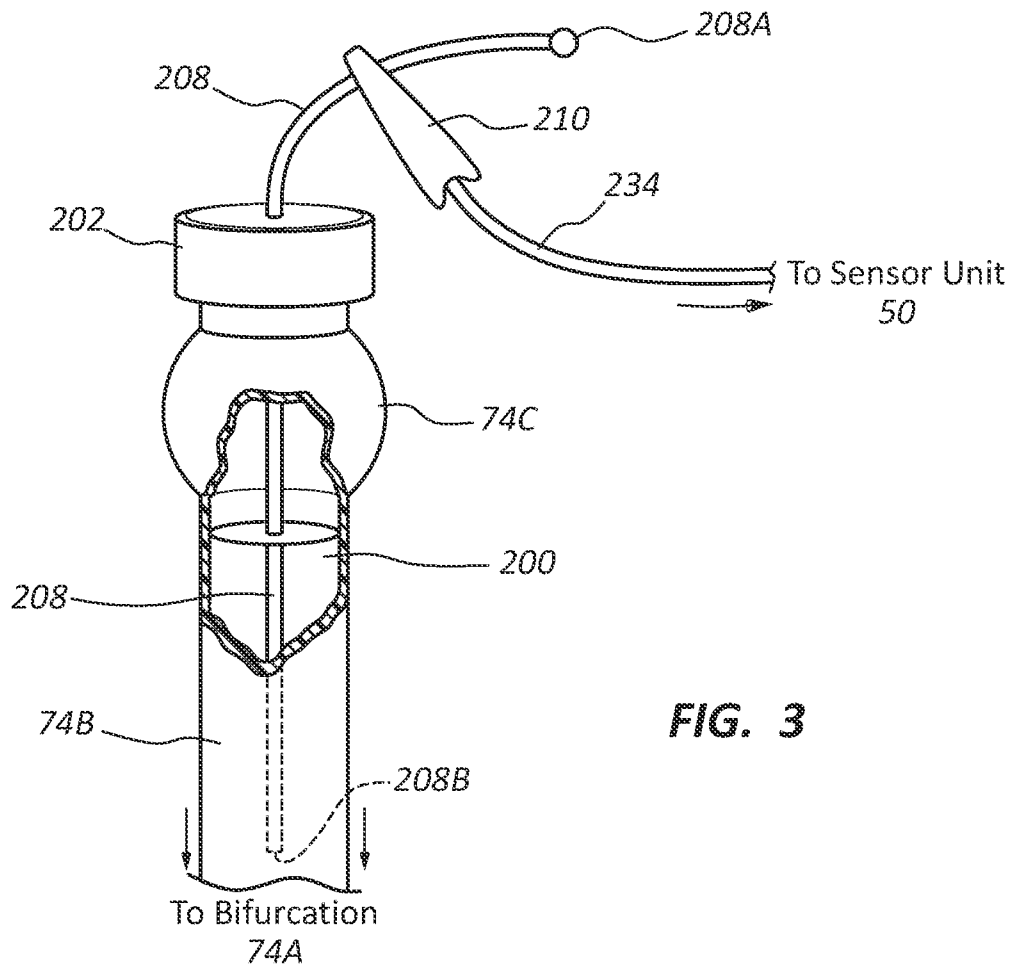

FIG. 3

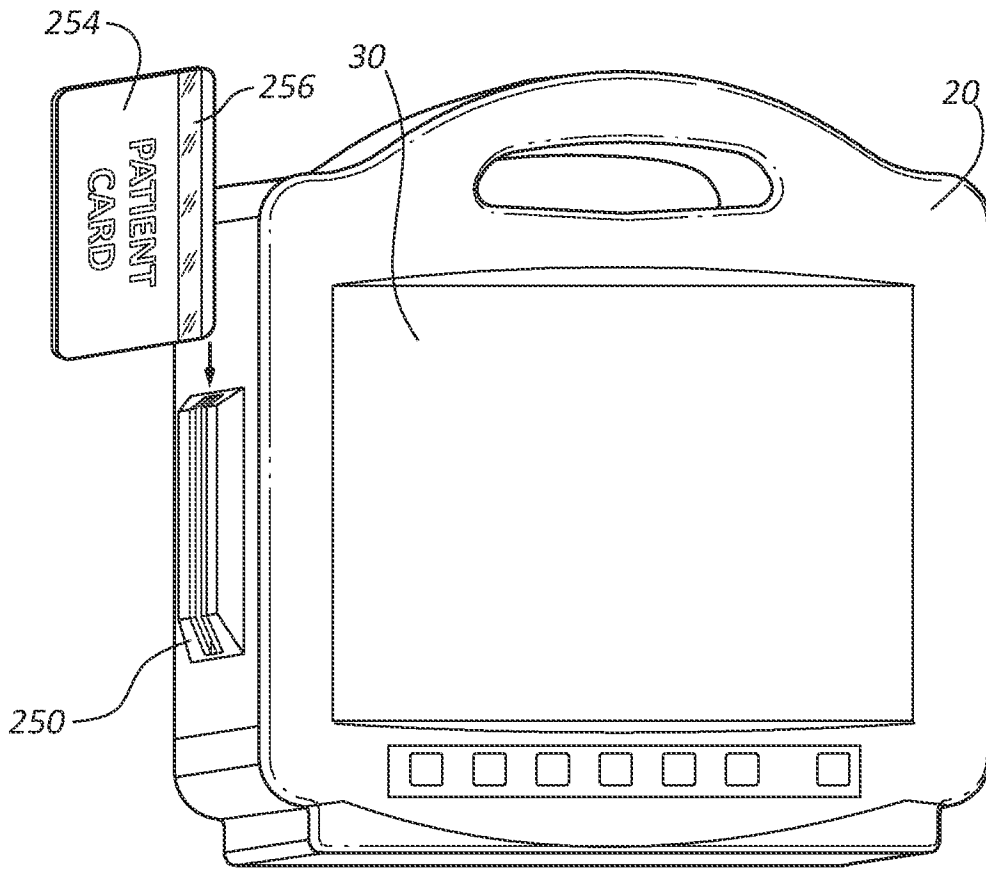

FIG. 4

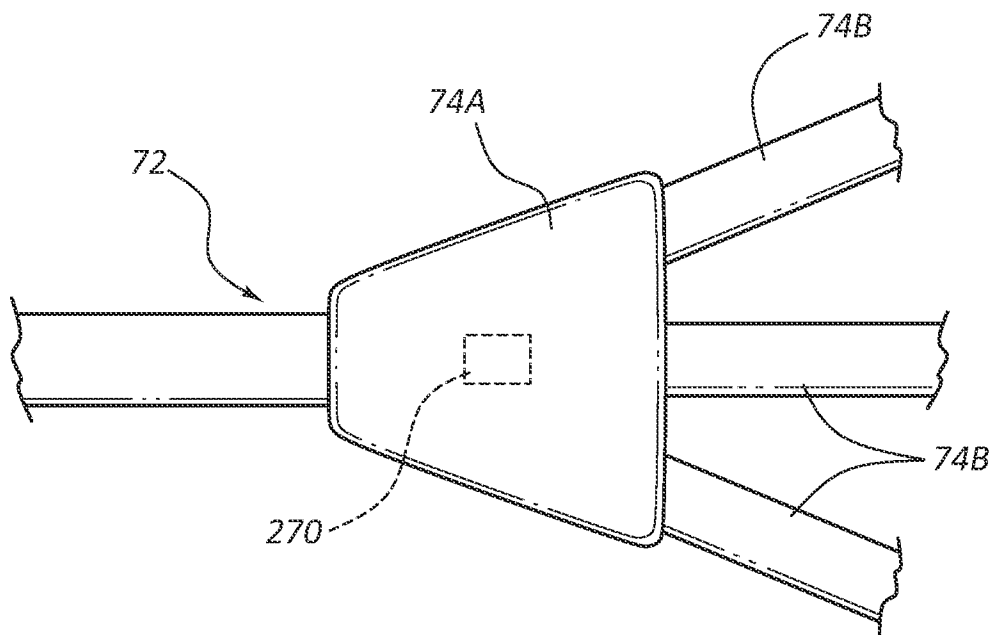

FIG. 5

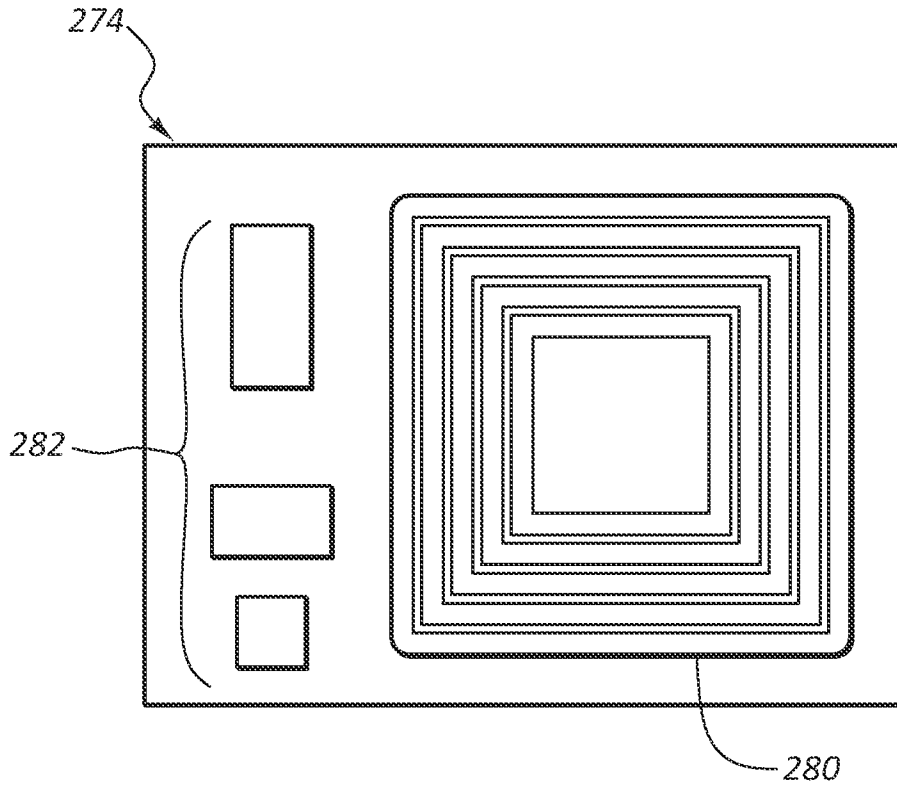

FIG. 6

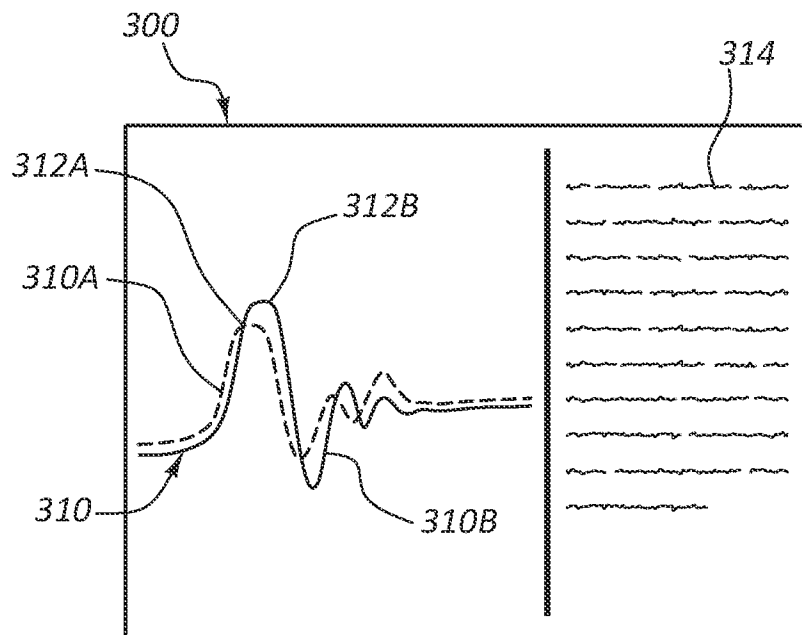

FIG. 7

专利名称(译)	重新确认ECG辅助导管尖端放置		
公开(公告)号	EP2605699A2	公开(公告)日	2013-06-26
申请号	EP2011818828	申请日	2011-08-19
申请(专利权)人(译)	C.R. BARD INC.		
当前申请(专利权)人(译)	C.R. BARD INC.		
[标]发明人	POWERS KELLY B BEASLEY JIM C		
发明人	POWERS, KELLY, B. BEASLEY, JIM, C.		
IPC分类号	A61B5/0402 A61B5/00 A61B5/042 A61B5/0452 A61B5/06 A61B8/00		
CPC分类号	A61M25/0105 A61B5/042 A61B5/04525 A61B5/065 A61B5/6851 A61B5/7246 A61B8/0841 A61B8/085 A61M2025/0166		
优先权	61/375442 2010-08-20 US		
其他公开文献	EP2605699A4		
外部链接	Espacenet		

摘要(译)

公开了借助于患者的ECG信号在血管内放置的导管的位置的重新确认，从而有助于确定患者脉管系统内的后续导管移位。在一个实施例中，一种用于再确认留置医疗设备在患者体内的位置的方法包括首先使用患者的ECG信号将医疗设备放置在患者体内。存储与初始放置医疗装置之后的留置医疗装置的初始位置有关的第一ECG信号轮廓。然后获取与初始放置医疗装置之后的留置医疗装置的位置有关的第二ECG信号轮廓。将第一ECG信号轮廓与第二ECG信号轮廓进行比较，以确定是否已经发生了留置医疗设备的位移。