



- (51) International Patent Classification:  
A61B 5/00 (2006.01) A61M 16/00 (2006.01)
- (21) International Application Number:  
PCT/US2010/027508
- (22) International Filing Date:  
16 March 2010 (16.03.2010)
- (25) Filing Language: English
- (26) Publication Language: English
- (30) Priority Data:  
12/411,014 25 March 2009 (25.03.2009) US
- (71) Applicant (for all designated States except US): NELL-COR PURITAN BENNETT LLC [US/US]; 6135 Gunbarrel Avenue, Boulder, Colorado 80301 (US).
- (72) Inventor; and
- (75) Inventor/Applicant (for US only): LOVEJOY, David [US/US]; 201 Woodside Lane, Thiensville, Wisconsin 53092 (US).
- (74) Agent: DOUGHERTY, Thomas; ATTN IP Legal, 6135 Gunbarrel Avenue, Boulder, Colorado 80301 (US).

- (81) Designated States (unless otherwise indicated, for every kind of national protection available): AE, AG, AL, AM, AO, AT, AU, AZ, BA, BB, BG, BH, BR, BW, BY, BZ, CA, CH, CL, CN, CO, CR, CU, CZ, DE, DK, DM, DO, DZ, EC, EE, EG, ES, FI, GB, GD, GE, GH, GM, GT, HN, HR, HU, ID, IL, IN, IS, JP, KE, KG, KM, KN, KP, KR, KZ, LA, LC, LK, LR, LS, LT, LU, LY, MA, MD, ME, MG, MK, MN, MW, MX, MY, MZ, NA, NG, NI, NO, NZ, OM, PE, PG, PH, PL, PT, RO, RS, RU, SC, SD, SE, SG, SK, SL, SM, ST, SV, SY, TH, TJ, TM, TN, TR, TT, TZ, UA, UG, US, UZ, VC, VN, ZA, ZM, ZW.
- (81) Designated States (unless otherwise indicated, for every kind of regional protection available): ARIPO (BW, GH, GM, KE, LS, MW, MZ, NA, SD, SL, SZ, TZ, UG, ZM, ZW), Eurasian (AM, AZ, BY, KG, KZ, MD, RU, TJ, TM), European (AT, BE, BG, CH, CY, CZ, DE, DK, EE, ES, FI, FR, GB, GR, HR, HU, IE, IS, IT, LT, LU, LV, MC, MK, MT, NL, NO, PL, PT, RO, SE, SI, SK, SM, TR), OAPI (BF, BJ, CF, CG, CI, CM, GA, GN, GQ, GW, ML, MR, NE, SN, TD, TG).

Published:  
— with international search report (Art. 21(3))

(54) Title: MEDICAL DEVICE FOR ASSESSING INTRAVASCULAR BLOOD VOLUME AND TECHNIQUE FOR USING THE SAME

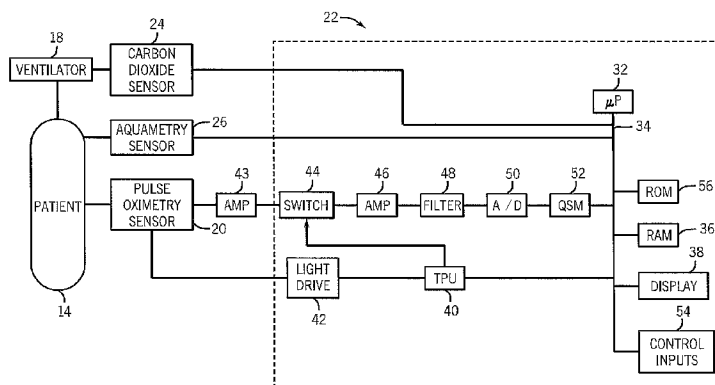

FIG. 2

(57) Abstract: Embodiments of the present invention relate to a system and method for determining a physiologic parameter of a patient. Specifically, embodiments of the present invention include methods and systems for correcting a pulse oximetry plethysmographic waveform variability measurement based on parameters that may influence the waveform variability. The corrected measurement may be used to estimate intravascular blood volume and/or fluid responsiveness of a patient.

WO 2010/111073 A1

# **MEDICAL DEVICE FOR ASSESSING INTRAVASCULAR BLOOD VOLUME AND TECHNIQUE FOR USING THE SAME**

## **BACKGROUND**

The present disclosure relates generally to a method and system for monitoring  
5 physiological parameters of a patient. Specifically, embodiments of the present invention  
relate to more accurate estimation of intravascular blood volume and fluid responsiveness  
by adjusting pulse oximetry waveform measurements to account for variations in  
respiratory parameters and/or other patient parameters.

This section is intended to introduce the reader to aspects of the art that may be  
10 related to various aspects of the present disclosure, which are described and/or claimed  
below. This discussion is believed to be helpful in providing the reader with background  
information to facilitate a better understanding of the various aspects of the present  
disclosure. Accordingly, it should be understood that these statements are to be read in  
this light, and not as admissions of prior art.

15 In the field of medicine, doctors often desire to monitor certain physiological  
characteristics of their patients. Accordingly, a wide variety of devices have been  
developed for monitoring many such characteristics of a patient. Such devices provide  
doctors and other healthcare personnel with the information they need to provide the best  
possible healthcare for their patients. As a result, such monitoring devices have become  
20 an indispensable part of modern medicine.

One physiological parameter that physicians may wish to monitor is blood fluid  
volume (i.e., intravascular volume). Variations from normal fluid volume in the blood  
may indicate a change in clinical condition or an injury. For example, hypovolemia is a

state of decreased intravascular volume that may be associated with dehydration. Correct clinical assessment of hypovolemia is complex. More specifically, intravascular volume is difficult to estimate, particularly in critically ill patients. Without an accurate assessment of a patient's intravascular volume, it is difficult to predict whether a patient will respond to fluid therapy (e.g., a blood or fluid infusion) with an improvement in clinical condition, such as an increase in stroke volume and cardiac output. Accordingly, accurate assessments of intravascular volume may assist a clinician in determining whether a patient will be responsive to fluid therapy.

To this end, indicators such as the systolic blood pressure variation, pulse pressure variation, or stroke volume variation may be used to estimate intravascular volume and determine whether a patient is likely to be fluid responsive. However, these measurements tend to be invasive. For example, to obtain an accurate pulse pressure waveform from which the intravascular volume can be determined, a physician may insert an invasive arterial line.

#### **BRIEF DESCRIPTION OF THE DRAWINGS**

Advantages of the disclosure may become apparent upon reading the following detailed description and upon reference to the drawings in which:

FIG. 1 is a block diagram of a ventilation system for determining intravascular blood volume in accordance with an embodiment;

FIG. 2 is a block diagram of a patient monitor that may be used in conjunction with the ventilation system of FIG. 1 in accordance with an embodiment;

FIG. 3 is a block diagram of a method illustrating an embodiment;

FIG. 4 is a plethysmographic waveform illustrating an embodiment; and

FIG. 5 is a block diagram of a closed-loop ventilation system for administering a fluid therapy in accordance with an embodiment.

5

### **DETAILED DESCRIPTION**

One or more specific embodiments of the present invention will be described below. In an effort to provide a concise description of these embodiments, not all features of an actual implementation are described in the specification. It should be appreciated that in the development of any such actual implementation, as in any engineering or design project, numerous implementation-specific decisions may be made to achieve the developers' specific goals, such as compliance with system-related and business-related constraints, which may vary from one implementation to another. Moreover, it should be appreciated that such a development effort might be complex and time consuming, but would nevertheless be a routine undertaking of design, fabrication, and manufacture for those of ordinary skill having the benefit of this disclosure.

For patients who are undergoing multiple and overlapping medical treatments, monitoring physiological parameters may be complex. For example, certain physiological characteristics of the patient may be influenced by the medical treatment being provided. In embodiments, a ventilator may control a patient's breathing rate along with the type and amount of gases inhaled. Because respiration affects the delivery of oxygen from the lungs into the blood, changes in ventilation parameters and/or patient lung conditions may

result in changes to hemodynamic parameters, such as pulse pressure and blood oxygenation.

The variability in a waveform representative of a patient's blood oxygen levels (i.e., a plethysmographic waveform) may be used to estimate a patient's intravascular volume. Blood oxygen levels may be monitored with a non-invasive, optical pulse oximetry sensor that transmits two or more wavelengths of light, most commonly red and near infrared wavelengths, through a patient's tissue and that photoelectrically detects the absorption and/or scattering of the transmitted light in such tissue. The use of pulse oximetry to estimate intravascular volume and fluid responsiveness in ventilated patients provides the ease of use of a noninvasive, rather than invasive, sensor. However, as noted, blood oxygen measurements may be affected by other clinical conditions, such as respiratory parameters. For example, the plethysmographic waveform signal may be sensitive to respiratory parameters, such as respiration rate, tidal volume, end tidal carbon dioxide concentration, or positive end-expiratory pressure, which may be controlled by particular settings on a ventilator. In addition, the plethysmographic waveform signal may be sensitive to tissue or blood constituent concentration, for example, a tissue water fraction or a partial pressure of carbon dioxide in the tissue. Further, the plethysmographic waveform signal may have certain patient-to-patient variability based on age, weight, gender, and clinical condition.

The plethysmographic waveform signal, or, in embodiments, a calculated value based on variation in the waveform signal, may be corrected or adjusted to provide a more accurate estimate of intravascular volume. A clinician may use the estimate of intravascular volume to make determinations about a patient's clinical condition, such as

the likelihood that the patient will respond to fluid therapy. The adjustment may correct for certain physiological conditions that may influence the plethysmographic waveform and that may either mask or exaggerate the plethysmographic waveform variability. For example, in the case of a ventilated patient with a controlled respiration rate, the patient's

5 blood oxygen saturation may be higher relative to a patient who is not receiving breathing assistance. Depending on the patient's clinical condition, a ventilated patient with generally higher respiration rate may have greater peak-to-peak variability in a plethysmographic waveform, which in turn would result in a higher calculated variability value. Typically, higher variability values (e.g., greater than 15% variability) may be

10 associated with increased fluid responsiveness. Accordingly, an artificially high variability value may mask a patient's true fluid responsiveness.

By correcting the variability of the plethysmographic signal to account for the influence of patient parameters, such as a higher respiration rate as a result of ventilation, the resulting plethysmographic waveform variability value may be more accurate.

15 Accordingly, a clinician may be able to make more informed decisions about whether the patient may benefit from fluid therapy. In addition, the clinician may be able to assess changes in blood volume more rapidly and may be able to intervene to provide therapy to the patient at an earlier time point. In embodiments, a closed-loop system is provided in which the corrected plethysmographic waveform variability is used to estimate the

20 intravascular volume and determine the fluid responsiveness of a patient. A closed-loop controller may control delivery of fluid therapy if the estimate of intravascular volume is associated with hypovolemia, which may indicate that the patient will be responsive to fluid therapy.

Embodiments provided herein are directed to medical devices for assessing intravascular volume based on respiratory or other patient parameters. Suitable devices may be incorporated into a respiratory system **10**, shown in **FIG. 1**, or any other patient monitoring system. In one embodiment, the respiratory system **10** may include a tracheal tube **12**, such as an endotracheal tube, that is inserted into a patient **14** to deliver gases to and from the patient's lungs. The respiratory system **10** may also include a respiratory circuit **16** connecting the tracheal tube **12** to a ventilator **18**. In embodiments, the ventilator **18** may be a positive pressure ventilator, such as those available from Nellcor Puritan Bennett LLC.

The system **10** may also include a pulse oximetry sensor **20** for generating a plethysmographic waveform signal representative of a patient's blood oxygen levels. The pulse oximetry sensor **20** may be in communication with a monitor **22** configured to receive the plethysmographic waveform signal and estimate the patient's intravascular volume and/or fluid responsiveness. In one embodiment, the monitoring functions of the monitor **22** may be incorporated into a single device that also performs the functions of ventilator **18**.

In embodiments, the plethysmographic waveform variability may be corrected by adjusting for respiratory parameters controlled by the ventilator **18**. For example, the ventilator **18** may include a controller for controlling respiration rate, tidal volume, flow rate, pressure, peak airway pressure, ratio of expiration to inspiration time, fraction of inspired oxygen (i.e., the percentage of oxygen in the gas mixture), inspired pressure increases or decreases over each breath (e.g., positive end-expiratory pressure), and any other respiratory parameter. Any suitable respiratory parameter controlled by the

ventilator **18** may be used to adjust an estimate of intravascular volume, as discussed in more detail below.

The respiratory system **10** may also include any number or combination of additional sensors for providing information related to patient parameters that may be used to correct or adjust the estimate of the patient's intravascular volume and/or fluid responsiveness. For example, suitable sensors may include sensors for determining tissue hydration, tissue constituents, blood constituents, blood pressure, heart rate, patient temperature, or tissue impedance. Such sensors may also include sensors for determining the presence or concentration of biomarkers, including sensors for circulating biomarkers related to cardiac stress and function (e.g., troponin or cholesterol) and/or biomarkers associated with lung function (e.g., surfactant protein D).

Suitable sensors for providing information about additional patient parameters may be optical, electrical, chemical, or biological sensors. A carbon dioxide sensor or tissue water fraction sensor may direct two or more wavelengths of light, most commonly near infrared wavelengths between about 1,000 nm to about 2,500 nm, into a sample, e.g., a gas sample or a tissue sample. Other sensors may include electrical sensors, such as electrical impedance sensors that may sense a voltage drop between two electrodes that are applied to a patient's tissue. Chemical sensors may include colorimetric chemical sensors, such as colorimetric sensors for detection of carbon dioxide. For example, a chemical sensor for carbon dioxide may include an indicator solution containing hydroxyl ions or amine residues that react chemically with carbon dioxide to form a carbonate and/or a bicarbonate or carbamate moiety, such as those discussed in co-pending U.S. Application No. 11/526,393 by Ostrowski et al., filed on September 25, 2006, the

specification of which is incorporated by reference in its entirety herein for all purposes.

This reaction may ultimately result in a color change that may be optically detected.

Biological sensors may include enzymatic sensors for detecting a color or fluorescence change produced by enzymatic reactions or by antibody/ligand binding. For example,

5 surfactant protein D may be detected by an enzyme-linked immunosorbent assay available from Cell Sciences (Canton, MA).

By way of example, **FIG. 1** shows a carbon dioxide sensor **24** that may be associated with the respiratory circuit **16** and an aquametry sensor **26** that may be applied to an appropriate tissue location on the patient **14**. However, it should be understood that

10 carbon dioxide sensor **24** and aquametry sensor **26** are merely illustrative of sensor types that may be used in conjunction with the respiratory system **10**. The carbon dioxide sensor **24** may be disposed along the respiratory circuit **16** (e.g., within a tube or connector of the respiratory circuit **16**) or associated with the respiratory circuit **16**. In addition, the carbon dioxide sensor **24** may be applied to a patient's tissue for determining

15 partial pressure of carbon dioxide by optically interrogating the tissue. Carbon dioxide sensor **24** may be connected to downstream monitor **22** and may provide the data used to correct or adjust pulse oximetry variability measurements as provided herein. For example, a carbon dioxide sensor **24** may provide information to the monitor **22** relating to a carbon dioxide concentration in the expired gas stream. Carbon dioxide

20 concentration measurements, e.g., capnography, may be used to estimate carbon dioxide partial pressure in arterial blood. In one embodiment, end-tidal CO<sub>2</sub> (the level of carbon dioxide released at the end of expiration) may be determined through capnography, which may be implemented by monitor **22**. In other embodiments, the capnography

measurements may be performed by a separate processor-based device, or may be performed by the ventilator 18. To coordinate the measurement of end-tidal CO<sub>2</sub> with the timing of the expiration, the ventilator 18 may provide information to the monitor 22 relating to the timing of the expiration and inhalation. For example, the respiration timing information may be used to control the carbon dioxide sensor 24.

The respiratory system 10 may include, either instead of or in addition to carbon dioxide sensor/s 24, any number of additional sensor types. For example, aquametry sensor 26 may be a sensor that may be applied to a patient's tissue for determining a tissue water fraction. The aquametry sensor 26 may include any suitable arrangement of optical components for spectrophotometrically assessing the patient's tissue water fraction. In one embodiment, the aquametry sensor 26 and the pulse oximetry sensor 20 may be integrated into a unitary sensor body.

The downstream monitor 22 may receive signals, for example from ventilator 18 or from one or more sensors 24 or 26, to correct or adjust pulse oximetry signals received from pulse oximetry sensor 20. FIG. 2 is a block diagram of an embodiment of a monitor 22 that may be configured to implement the embodiments of the present disclosure. The pulse oximetry signal from the pulse oximetry sensor 20 may generate a plethysmographic waveform, which may be further processed and corrected by the monitor 22. The monitor 22 may receive and further process a signal from carbon dioxide sensor 24 to determine a value representative of a concentration of carbon dioxide in the respiratory circuit 16 and/or a signal from aquametry sensor 26 to determine a value representative of a tissue water fraction of the patient.

The monitor **22** may include a microprocessor **32** coupled to an internal bus **34**. Also connected to the bus may be a RAM memory **36** and a display **38**. A time processing unit (TPU) **40** may provide timing control signals to light drive circuitry **42**, which controls when an optical sensor (e.g., pulse oximetry sensor **20**, carbon dioxide sensor **24**, or tissue water fraction sensor **26**) is activated, and, if multiple light sources are used, the multiplexed timing for the different light sources. TPU **40** may also control the gating-in of signals from sensor **20** through an amplifier **43** and a switching circuit **44**. These signals are sampled at the proper time, depending at least in part upon which of multiple light sources is activated, if multiple light sources are used. The received signal from the pulse oximetry sensor **20** may be passed through an amplifier **46**, a low pass filter **48**, and an analog-to-digital converter **40**. The digital data may then be stored in a queued serial module (QSM) **52**, for later downloading to RAM **46** or ROM **56** as QSM **52** fills up.

In an embodiment, based at least in part upon the received signals corresponding to the light received by optical components of the pulse oximetry sensor **20**, microprocessor **32** may calculate the oxygen saturation using various algorithms. In addition, the microprocessor **32** may calculate a plethysmographic waveform variation using various algorithms, such as suitable statistical or time-series analysis algorithms. The plethysmographic waveform variation may be corrected based on input signals from other sensors (e.g., carbon dioxide sensor **24** or aquametry sensor **26**), the ventilator **18**, or caregiver inputs to control inputs **54**. For example, the caregiver may input a patient's age, weight, gender, or information about the patient's clinical condition that may be relevant to the accurate estimation of the intravascular volume. These algorithms may

employ certain coefficients, which may be empirically determined, and may correspond to the wavelengths of light used. In addition, the algorithms may employ additional correction coefficients. By way of example, a particular end tidal carbon dioxide measurement, as generated from a signal provided by carbon dioxide sensor **24**, may be associated with a particular correction coefficient. The algorithms and coefficients may be stored in a ROM **56** or other suitable computer-readable storage medium and accessed and operated according to microprocessor **32** instructions. In one embodiment, the correction coefficients may be provided as a lookup table.

A patient's intravascular volume may be determined based on the corrected variability of a pulse oximetry plethysmographic waveform that is adjusted based on patient parameters. **FIG. 3** is a process flow diagram illustrating a method **64** in accordance with some embodiments. The method may be performed as an automated procedure by a system, such as system **10**. In addition, certain steps of the method may be performed by a processor, or a processor-based device such as a patient monitor **22** that includes instructions for implementing certain steps of the method **64**.

According to an embodiment, the method **64** begins with obtaining a plethysmographic waveform signal from a pulse oximetry sensor **20** at step **66**. Additional data relating to one or more patient parameters is obtained at step **68**. The data relating to one or more patient parameters may be received from the ventilator **18**, or may be calculated from signals received from patient sensors, e.g., carbon dioxide sensor **24** or aquametry sensor **26**. In addition, the data relating to one or more patient parameters may be manually input by a healthcare provider.

The monitor **22** may perform analysis of the plethysmographic waveform signal and calculation of the plethysmographic waveform variability at step **70** based on the plethysmographic waveform signal obtained at step **66** and the additional patient parameter data obtained at step **68**. The mathematical model for adjusting the waveform variability based on additional patient parameters obtained in step **68** may be linear or nonlinear, multivariate, partial least squares, principal component regression, autoregressive moving average, mathematical curve fitting or simply an additive constant to the variability value. In one embodiment, the waveform variability is first calculated to provide a percentage value, and then the percentage value is adjusted based on the patient parameters.

In embodiments, the plethysmographic waveform signal may be modified or filtered based on the patient parameters prior to the calculation of the waveform variability to provide an adjusted or corrected variability value. For example, if a patient parameter is associated with having a damping effect on the waveform, the damping effect may be quantified and a filter may be used to remove the damping effect. In addition, the variability of the AC component (i.e., the pulsatile component) of the plethysmographic waveform signal, and not the DC component (i.e., the nonpulsatile component), may be used for assessing the intravascular blood volume. Accordingly, the DC component may be filtered out or otherwise removed from the waveform prior to the analysis in step **70**.

**FIG. 4** illustrates a plethysmographic waveform **80** from which the plethysmographic waveform variability,  $W_v$ , may be determined based on the following equation:

$$W_v = (W_{\max} - W_{\min}) / W_{\text{mean}}$$

where  $W_{\max}$  is a maximum peak value, taken as a vertical distance **82** between a peak **84** and trough **86** for a largest peak **88** (i.e., a single cardiac cycle) and  $W_{\min}$  is a minimum peak value, taken as vertical distance **90** between a peak **92** and trough **94** for a smallest peak **96** within a window **98** of consecutive peaks.  $W_{\text{mean}}$  represents the mean vertical distance between peak maxima and minima for the consecutive peaks in the window **98**. The window **98** may be a total number of peaks, such as 5 consecutive peaks, or may include all consecutive peaks within a time window, such as 10 seconds. In embodiments, an operator may adjust the settings on a monitor to change the size of the window according to the desired monitoring parameters. For example, an operator may increase the size of the window **98** from 10 seconds to 30 seconds to capture more data prior to providing the waveform variability. This may provide more accurate and/or stable waveform variability values, but may also slow the updating. The monitor **22** may provide rolling updates as the window **98** moves forward in time.

Turning back to **FIG. 3**, one or more patient parameters may be used to adjust or correct the calculated plethysmographic waveform variability at step **70**. In general, certain patient conditions may influence or have a correlative or inverse correlative relationship with the plethysmographic waveform. For example, the plethysmographic waveform variability may be particularly sensitive to vasoconstriction. In embodiments, the monitor **22** may allow a clinician to input information into the monitor related to whether or not the patient is taking any vasoconstrictive drugs, such as vasopressin analogs. Because vasoconstriction may increase cardiac preload and cardiac output, the resultant plethysmographic waveform may be adjusted to account for the effects of

vasoconstrictive drugs. Similarly, certain clinical conditions may cause vasoconstriction, including stress and hypothermia. Accordingly, information from temperature sensors may provide information about whether or not vasoconstriction may be a factor in influencing the plethysmographic waveform variability. When patient parameters  
5 indicative of vasoconstriction are available, the plethysmographic waveform variability may be adjusted accordingly.

Similarly, information relating to whether or not a patient is receiving positive end expiratory pressure (PEEP) ventilation may be used to adjust the plethysmographic waveform variability. PEEP can cause significant hemodynamic consequences through  
10 decreasing venous return to the right heart and decreasing right ventricular function. PEEP may increase intrathoracic pressure, leading to a resulting decrease in venous return and decrease in cardiac output. Accordingly, information relating to PEEP may be used to adjust the plethysmographic waveform variability to a lower threshold value indicative of hypovolemia, as discussed below. For example, because PEEP and intravascular  
15 volume depletion may be contraindicated, a patient receiving PEEP may be closely monitored for hypovolemia and may have a lower plethysmographic waveform variability threshold. In addition, PEEP may lead to an increase in plethysmographic waveform variability, meaning that the plethysmographic waveform variability may be adjusted downwards to account for the effects of PEEP.

20 A patient parameter may also be used to determine if plethysmographic waveform variability is likely to be accurate for the patient in question. For example for patients with normal tidal volumes, e.g., between 8 and 15 kg/ml, the plethysmographic waveform variability value may be a generally accurate estimate of intravascular volume or fluid

responsiveness. Accordingly, for these patients, the plethysmographic waveform variability value may not be adjusted when their tidal volumes are in the normal range. However, for patients outside of the range of normal tidal volumes, the plethysmographic waveform variability value may be less accurate and may be adjusted according to its  
5 relationship with tidal volumes outside of normal ranges.

In embodiments, tissue water fraction information from an aquametry sensor 26 may be used to adjust the plethysmographic waveform variability. Because plethysmographic waveform variability may be used as a surrogate for blood volume, information about the hydration state of other compartments, such as the tissue, may  
10 provide additional information for assessing intravascular blood volume. Total body water depletion through dehydration may lead to poor intravascular volume. The body may protectively shunt blood towards the most vital organs (heart, kidney and brain) and away from peripheral organs such as the intestines, muscles and skin. Hence, the earliest sign of dehydration may be seen in the skin and muscle tissues. A reduced extracellular  
15 fluid volume, e.g., tissue water fraction, may be an early indicator of low intravascular volume. A tissue water fraction may be determined according to methods discussed in U.S. Patent Application No. 11/716,443 to Hausmann et al., filed on March 9, 2007, the specification of which is incorporated by reference herein in its entirety for all purposes. If the tissue water fraction is associated with a low level of hydration, the  
20 plethysmographic waveform variability may be increased or adjusted upwards to reflect a higher likelihood of hypovolemia. In addition, the tissue water fraction may be used as a confirmation or confidence check for the plethysmographic waveform variability.

Further, information from a carbon dioxide sensor **24** may be used to adjust the plethysmographic waveform variability. Abnormally low levels of carbon dioxide in end tidal breaths may correlate with a concurrent decrease in blood volume. Accordingly, the plethysmographic waveform variability may be increased or adjusted upwards to reflect a higher likelihood of hypovolemia for patients with decreased end tidal carbon dioxide levels.

The monitor **22** may calculate the adjusted plethysmographic variability value and provide a display or other indication to a clinician, such as a graphical, visual, or audio representation of the intravascular volume at step **72**. For example, an adjusted plethysmographic variability value associated with normal intravascular blood volume may include a numeric value or a green light indicated on a display or a short tone generated by a speaker associated with monitor **22**. Similarly, an adjusted plethysmographic variability value associated with hypovolemia may trigger an alarm, which may include one or more of an audio or visual alarm indication. Further, the monitor **22** may provide a confidence metric or indicator to provide information to the clinician relating to how many parameters may have been taken into account. For example, if the plethysmographic variability value is consistent with trends from two or more additional patient parameters, the confidence may be higher than if only one patient parameter is used.

In one embodiment, the alarm may be triggered if the adjusted plethysmographic variability value is substantially greater than a predetermined value, substantially less than a predetermined value, or outside of a predetermined range. In one embodiment, a plethysmographic variability value of 10-15% may be considered to be indicative of a

non-responsive or normovolemic patient that would not benefit from a fluid infusion. In addition, a plethysmographic variability value above 15% may be considered to be indicative of a hypovolemic patient that would likely benefit from a fluid infusion with respect to increasing cardiac output and improving the overall state of oxygenation.

5 Accordingly, an alarm may be triggered when the plethysmographic waveform variability value is above 15% to alert a clinician that the patient may benefit from fluid therapy.

In other embodiments, a patient respiratory system **100** may operate under closed-loop control to provide to delivery of a fluid therapy (e.g., saline, blood, or other fluid) to a patient **14**. **FIG. 5** shows a system **100** under control of a primary controller **102** that  
10 may include a closed-loop controller that cooperates with a monitor **22** to control delivery of fluid therapy to the patient **14**. The primary controller **102** may receive input from the monitor **22**. Based on the plethysmographic waveform signal from the pulse oximetry sensor **20** as well as additional patient parameter information, such as the settings of ventilator **18** or the inputs from additional patient sensors, the monitor **22** may calculate a  
15 plethysmographic waveform variability value. The plethysmographic waveform variability value may be used by the controller **102** to control the fluid delivery device **104**. It should be understood that while **FIG. 5** depicts the controller **102** and the monitor **22** as separate devices, the monitoring functions of monitor **22** and the controller functions of controller **102** may be incorporated into a single device in embodiments.

20 For example, the controller **102** may receive a request for increased fluid from the monitor **22** when a measured plethysmographic waveform variability value, adjusted with regard to available patient parameters, is above a predefined target, e.g., above 15%. The fluid delivery device **104** may include a peristaltic pump or other type of pump attached to

an automatic intravenous line to achieve the desired delivery rate of the fluid to the patient. To control the rate at which the pump infuses the fluid, the speed of the pump may be controlled by the closed-loop controller **102**. When the plethysmographic waveform variability value falls below 15%, the controller **102** may slow or stop delivery  
5 of fluid from the fluid delivery device **104**. If the monitor **22** fails to determine that a plethysmographic waveform variability value has decreased after a set time, the controller **102** may generate a signal notifying a caregiver of prolonged hypovolemia or may cease delivery of fluids.

While the invention may be susceptible to various modifications and alternative  
10 forms, specific embodiments have been shown by way of example in the drawings and will be described in detail herein. However, it should be understood that the invention is not intended to be limited to the particular forms disclosed. Rather, the invention is to cover all modifications, equivalents and alternatives falling within the spirit and scope of the invention as defined by the following appended claims.

## CLAIMS

What is claimed is:

1. A method, comprising:  
using a processor:  
receiving a plethysmographic waveform signal from a sensor, wherein the plethysmographic waveform signal is generally representative of a blood oxygen saturation of a patient;  
receiving information related to a patient parameter that may influence the plethysmographic waveform signal; and  
determining plethysmographic waveform variability based at least in part on the plethysmographic waveform signal and/or the information related to the patient parameter.
2. The method of claim 1, comprising providing an indication of intravascular blood volume based on the plethysmographic waveform variability.
3. The method of claim 1, comprising triggering an alarm when the plethysmographic waveform variability is greater than a predetermined level or outside of a predetermined range.
4. The method of claim 3, wherein the predetermined level is about 15%.
5. The method of claim 1, wherein the information related to the patient parameter comprises a tissue carbon dioxide level, a tissue water fraction, and/or a combination thereof.
6. The method of claim 1, wherein the information related to the patient parameter comprises a ventilator setting of positive end pressure ventilation, a tidal volume, a respiration rate, an end-tidal carbon dioxide level, and/or any combination thereof.

7. The method of claim 1, wherein the information related to the patient parameter comprises a clinical condition of the patient and/or information related to a pharmacological treatment.

8. The method of claim 7, wherein the clinical condition comprises a likelihood of vasoconstriction.

9. A monitor, comprising:  
 an input circuit capable of receiving a plethysmographic waveform signal and information relating to a patient parameter that influences the plethysmographic waveform signal;

a memory storing an algorithm configured to calculate a plethysmographic waveform variability based at least in part on the plethysmographic waveform signal and/or the information related to the patient parameter; and

an output circuit configured to provide an indication of the plethysmographic waveform variability.

10. The monitor of claim 9, wherein the information relating to a patient parameter comprises information received from a carbon dioxide sensor and/or a tissue water fraction sensor.

11. The monitor of claim 9, wherein the information relating to a patient parameter comprises respiratory parameter information.

12. The monitor of claim 9, wherein the algorithm comprises the following equation:

$$W_v = (W_{\max} - W_{\min}) / W_{\text{mean}},$$

wherein  $W_v$  is the plethysmographic waveform variability,  $W_{\max}$  is a maximum peak value for a largest peak,  $W_{\min}$  is a minimum peak value for a smallest peak, and

$W_{\text{mean}}$  represents the mean vertical distance between peak maxima and minima for the consecutive peaks in the window within a window of consecutive peaks.

13. The monitor of claim 9, wherein the information related to the patient parameter comprises a tidal volume, and wherein the algorithm is configured to adjust the plethysmographic waveform variability when the tidal volume is outside of a range of between about 8 to about 15 kg/ml.

14. The monitor of claim 9, wherein the information relating to the patient parameter comprises information that the patient is undergoing positive end expiratory pressure ventilation, and wherein the algorithm is configured to increase the plethysmographic waveform variability based on the information.

15. The monitor of claim 9, wherein the information relating to the patient parameter comprises information that the patient is receiving vasoconstrictive drugs, and wherein the algorithm is configured to adjust the plethysmographic waveform variability based on the information.

16. A system for automatically controlling delivery of a fluid, comprising:  
a delivery mechanism capable of delivering a fluid to a patient; and  
a controller, wherein the controller is capable of:

receiving a plethysmographic waveform signal and information relating to a patient parameter that influences the plethysmographic waveform signal;

determining a plethysmographic waveform variability based at least in part on the plethysmographic waveform signal and the information related to the patient parameter; and

generally automatically adjusting delivery of the fluid based on a comparison of the plethysmographic waveform variability with a predetermined value.

17. The system of claim 16, comprising a ventilator capable of delivering a gas mixture to the patient, wherein the information related to the patient parameter comprises a setting or parameter of the ventilator.

18. The system of claim 16, wherein the delivery mechanism is capable of delivering the fluid comprises an intravenous fluid pump.

19. The system of claim 16, comprising a sensor capable of providing the information related to the patient parameter physiologic parameter.

20. The system of claim 19, wherein the sensor comprises a carbon dioxide sensor and/or a tissue water fraction sensor.

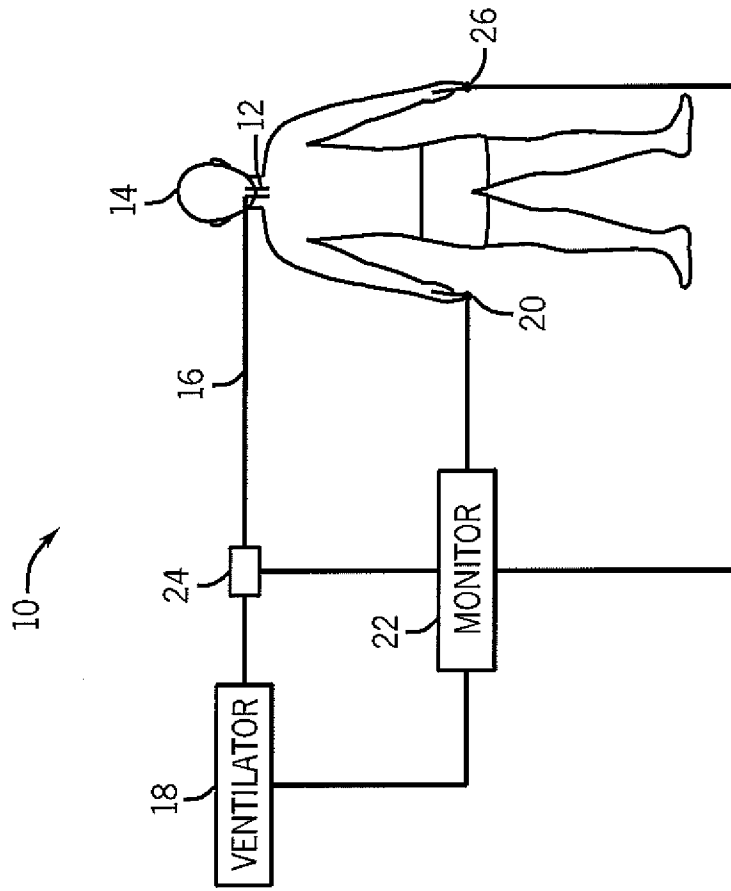

FIG. 1



3 / 5

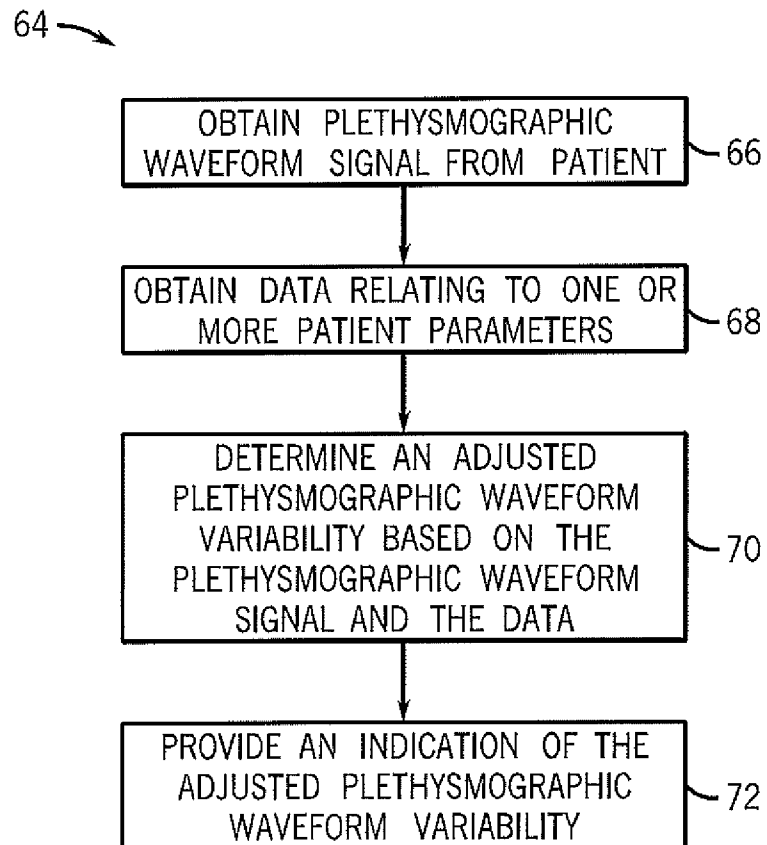

FIG. 3

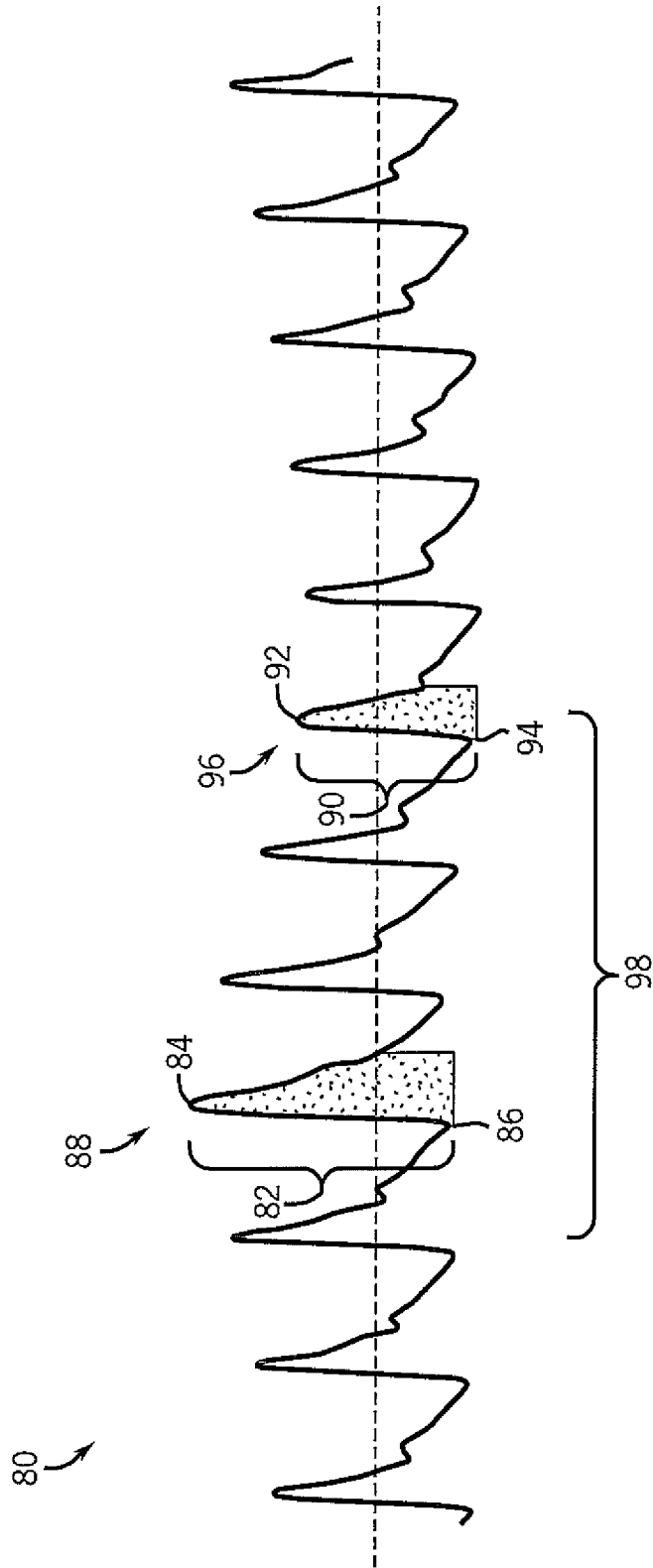

FIG. 4

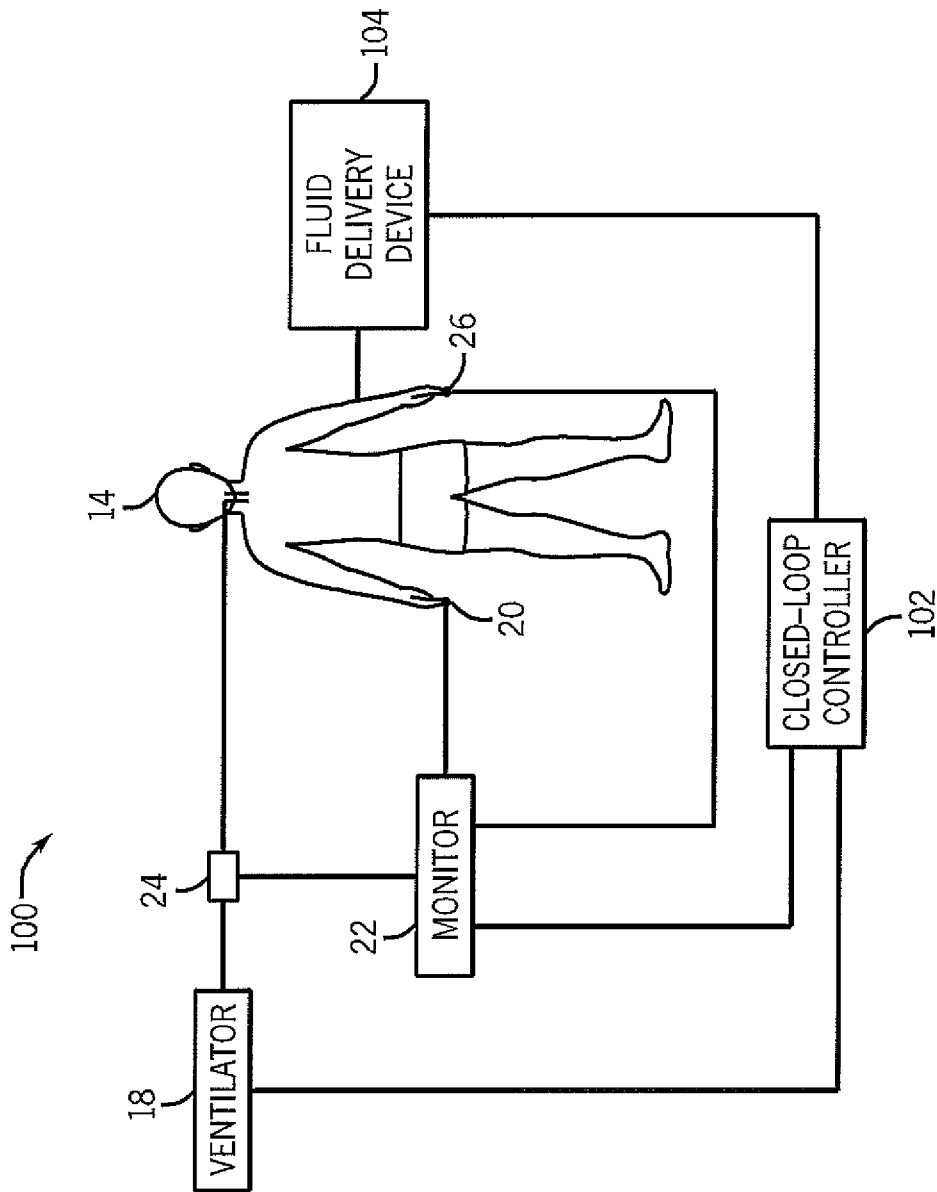

FIG. 5

**INTERNATIONAL SEARCH REPORT**

International application No  
PCT/US2010/027508

**A. CLASSIFICATION OF SUBJECT MATTER**  
INV. A61B5/00 A61M16/00  
ADD.

According to International Patent Classification (IPC) or to both national classification and IPC

**B. FIELDS SEARCHED**

Minimum documentation searched (classification system followed by classification symbols)  
A61B A61M

Documentation searched other than minimum documentation to the extent that such documents are included in the fields searched

Electronic data base consulted during the international search (name of data base and, where practical, search terms used)

EPO-Internal

**C. DOCUMENTS CONSIDERED TO BE RELEVANT**

Category*	Citation of document, with indication, where appropriate, of the relevant passages	Relevant to claim No.
X Y	US 2006/058691 A1 (KIANI MASSI E [US]) 16 March 2006 (2006-03-16) the whole document	1-4,6,9, 11,12 5,7,8, 10,16-20
Y	----- US 2009/076462 A1 (KIANI MASSI E [US]) 19 March 2009 (2009-03-19) the whole document	16-20
Y	----- US 2004/260186 A1 (DEKKER ANDREAS LUBBERTUS ALOYS [NL]) 23 December 2004 (2004-12-23) paragraph [0072]; figures 7,8	7,8
Y	----- WO 02/075289 A2 (NELLCOR PURITAN BENNETT INC [US]) 26 September 2002 (2002-09-26) page 1, line 3 - line 7 page 4, line 12 - line 17 ----- -/-	5,10

Further documents are listed in the continuation of Box C.

See patent family annex.

\* Special categories of cited documents :

- \*A\* document defining the general state of the art which is not considered to be of particular relevance
- \*E\* earlier document but published on or after the international filing date
- \*L\* document which may throw doubts on priority claim(s) or which is cited to establish the publication date of another citation or other special reason (as specified)
- \*O\* document referring to an oral disclosure, use, exhibition or other means
- \*P\* document published prior to the international filing date but later than the priority date claimed

- \*T\* later document published after the international filing date or priority date and not in conflict with the application but cited to understand the principle or theory underlying the invention
- \*X\* document of particular relevance; the claimed invention cannot be considered novel or cannot be considered to involve an inventive step when the document is taken alone
- \*Y\* document of particular relevance; the claimed invention cannot be considered to involve an inventive step when the document is combined with one or more other such documents, such combination being obvious to a person skilled in the art.
- \*&\* document member of the same patent family

Date of the actual completion of the international search

10 June 2010

Date of mailing of the international search report

17/06/2010

Name and mailing address of the ISA/  
European Patent Office, P.B. 5818 Patentlaan 2  
NL - 2280 HV Rijswijk  
Tel. (+31-70) 340-2040,  
Fax: (+31-70) 340-3016

Authorized officer

Hunt, Brynley

## INTERNATIONAL SEARCH REPORT

International application No  
PCT/US2010/027508

C(Continuation). DOCUMENTS CONSIDERED TO BE RELEVANT		
Category*	Citation of document, with indication, where appropriate, of the relevant passages	Relevant to claim No.
A	<p>WO 2008/073855 A2 (MASIMO CORP [US]; AL-ALI AMMAR [US]; WEBER WALTER [US]; MAJMUDAR ANMOL) 19 June 2008 (2008-06-19) paragraph [0019] paragraphs [0021] - [0026] paragraphs [0027] - [0031] paragraph [0033] -----</p>	1,9,12, 16
A	<p>US 6 099 481 A (DANIELS RICH H [US] ET AL) 8 August 2000 (2000-08-08) column 6, line 40 - line 43 column 7, line 59 - column 8, line 7 -----</p>	13,14
A	<p>WO 2006/086085 A2 (HYPERMED INC [US]; PANASYUK SVETLANA V [US]; FREEMAN JENNY E [US]; HOP) 17 August 2006 (2006-08-17) page 25, line 24 - line 28 -----</p>	15
A	<p>US 2008/200775 A1 (LYNN LAWRENCE A [US]) 21 August 2008 (2008-08-21) paragraphs [0011], [0014] -----</p>	14,15

# INTERNATIONAL SEARCH REPORT

Information on patent family members

International application No PCT/US2010/027508
---

Patent document cited in search report	Publication date	Patent family member(s)	Publication date
US 2006058691	A1	16-03-2006	NONE
US 2009076462	A1	19-03-2009	NONE
US 2004260186	A1	23-12-2004	AU 2003217564 A1 09-09-2003 CN 1646055 A 27-07-2005 EP 1485009 A1 15-12-2004 JP 2005535359 T 24-11-2005 WO 03071938 A1 04-09-2003
WO 02075289	A2	26-09-2002	CA 2441017 A1 26-09-2002 DE 60223787 T2 27-11-2008 EP 1368638 A2 10-12-2003 ES 2299558 T3 01-06-2008 HK 1063072 A1 11-04-2008 JP 4176480 B2 05-11-2008 JP 2004523320 T 05-08-2004 US 2002165439 A1 07-11-2002
WO 2008073855	A2	19-06-2008	EP 2096994 A2 09-09-2009 US 2008188760 A1 07-08-2008
US 6099481	A	08-08-2000	US 6179784 B1 30-01-2001
WO 2006086085	A2	17-08-2006	AU 2005327078 A1 17-08-2006 CA 2592691 A1 17-08-2006 EP 1835845 A2 26-09-2007 JP 2008525158 T 17-07-2008
US 2008200775	A1	21-08-2008	CA 2678856 A1 28-08-2008 EP 2124730 A1 02-12-2009 WO 2008103389 A1 28-08-2008

专利名称(译)	用于评估血管内血容量的医疗设备和使用该设备的技术		
公开(公告)号	<a href="#">EP2410904A1</a>	公开(公告)日	2012-02-01
申请号	EP2010710136	申请日	2010-03-16
[标]申请(专利权)人(译)	内尔科尔普里坦贝内特公司		
申请(专利权)人(译)	NELLCOR PURITAN BENNETT LLC		
当前申请(专利权)人(译)	COVIDIEN LP		
[标]发明人	LOVEJOY DAVID		
发明人	LOVEJOY, DAVID		
IPC分类号	A61B5/00 A61M16/00 A61B5/02 A61B5/1455		
CPC分类号	A61B5/14551 A61B5/02028 A61B5/4839 A61M16/0051 A61M16/026 A61M2230/205		
优先权	12/411014 2009-03-25 US		
其他公开文献	EP2410904B1		
外部链接	<a href="#">Espacenet</a>		

#### 摘要(译)

本发明的实施例涉及用于确定患者的生理参数的系统和方法。具体地，本发明的实施例包括用于基于可能影响波形可变性的参数来校正脉搏血氧饱和度体积描记波形可变性测量的方法和系统。校正的测量值可用于估计患者的血管内血液量和/或液体反应性。