

(19) World Intellectual Property Organization
International Bureau



(43) International Publication Date
11 June 2009 (11.06.2009)

PCT

(10) International Publication Number
WO 2009/073852 A1

- (51) International Patent Classification:
H04R 1/00 (2006.01)
- (21) International Application Number:
PCT/US2008/085706
- (22) International Filing Date:
5 December 2008 (05.12.2008)
- (25) Filing Language: English
- (26) Publication Language: English
- (30) Priority Data:
11/952,780 7 December 2007 (07.12.2007) US
- (63) Related by continuation (CON) or continuation-in-part (CIP) to earlier application:
US 11/952,780 (CON)
Filed on 7 December 2007 (07.12.2007)

(74) Agents: HAN, Johny U. et al.; Levine Bagade Han LLP, 2400 Geng Road, Suite 120, Palo Alto, California 94303 (US).

(81) Designated States (unless otherwise indicated, for every kind of national protection available): AE, AG, AL, AM, AO, AT, AU, AZ, BA, BB, BG, BH, BR, BW, BY, BZ, CA, CH, CN, CO, CR, CU, CZ, DE, DK, DM, DO, DZ, EC, EE, EG, ES, FI, GB, GD, GE, GH, GM, GT, HN, HR, HU, ID, IL, IN, IS, JP, KE, KG, KM, KN, KP, KR, KZ, LA, LC, LK, LR, LS, LT, LU, LY, MA, MD, ME, MG, MK, MN, MW, MX, MY, MZ, NA, NG, NI, NO, NZ, PG, PH, PL, PT, RO, RS, RU, SC, SD, SE, SG, SK, SL, SM, ST, SV, SY, TJ, TM, TN, TR, TT, TZ, UA, UG, UZ, VC, VN, ZA, ZM, ZW.

(84) Designated States (unless otherwise indicated, for every kind of regional protection available): ARIPO (BW, GH, GM, KE, LS, MW, MZ, NA, SD, SL, SZ, TZ, UG, ZM, ZW), Eurasian (AM, AZ, BY, KG, KZ, MD, RU, TJ, TM), European (AT, BE, BG, CH, CY, CZ, DE, DK, EE, ES, FI, FR, GB, GR, HR, HU, IE, IS, IT, LT, LU, LV, MC, MT, NL, NO, PL, PT, RO, SE, SI, SK, TR), OAPI (BF, BJ, CF, CG, CI, CM, GA, GN, GQ, GW, ML, MR, NE, SN, TD, TG).

(71) Applicant (for all designated States except US): SONITUS MEDICAL, INC. [US/US]; 1825 S. Grant Street, Suite 350, San Mateo, California 94402 (US).

(72) Inventors; and
(75) Inventors/Applicants (for US only): ABOLFATHI, Amir [US/US]; 2150 Stockbridge Avenue, Woodside, California 94062 (US). KASSAYAN, Reza [IR/US]; 61 Parker Avenue, Atherton, California 94027 (US).

Declaration under Rule 4.17:
— as to applicant's entitlement to apply for and be granted a patent (Rule 4.17(ii))
Published:
— with international search report

(54) Title: SYSTEM AND METHOD TO PROVIDE TWO-WAY COMMUNICATIONS TO AND FROM A MOUTH WEARABLE COMMUNICATOR

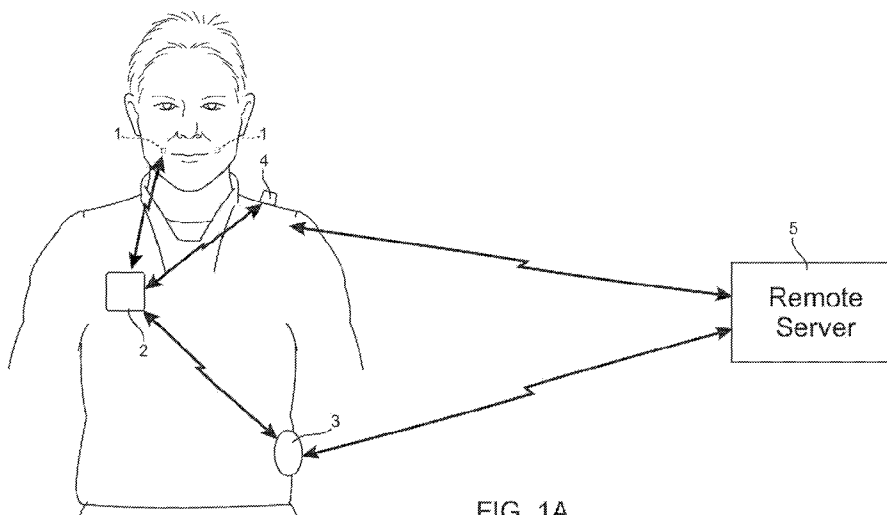

FIG. 1A

(57) Abstract: An electronic and transducer device can be attached, adhered, or otherwise embedded into or upon a removable oral appliance or other oral device to form a two-way communication assembly. In another embodiment, the device provides an electronic and transducer device that can be attached, adhered, or otherwise embedded into or upon a removable oral appliance or other oral device to form a medical tag containing patient identifiable information. Such an oral appliance may be a custom-made device fabricated from a thermal forming process utilizing a replicate model of a dental structure obtained by conventional dental impression methods. The electronic and transducer assembly may receive incoming sounds either directly or through a receiver to process and amplify the signals and transmit the processed sounds via a vibrating transducer element coupled to a tooth or other bone structure, such as the maxillary, mandibular, or palatine bone structure.

WO 2009/073852 A1

SYSTEM AND METHOD TO PROVIDE TWO-WAY COMMUNICATIONS TO AND FROM A MOUTH WEARABLE COMMUNICATOR

BACKGROUND

[0001] Traditionally field workers such as fire fighters and plant workers communicate using two way radios such as radios supplied by Motorola, Inc. As mentioned in United States Patent 20070142072, two way radios allow users the ability to wirelessly communicate with others on a small network. Most two way radios use various channels or frequencies for communication. Monitoring of more than one channel allows a user to communicate with a plurality of people for a variety of purposes. In a security environment, for instance, channel 1 may be used to communicate about and monitor emergency conditions. Channel 2 may be used to communicate about and monitor major security threats. Channel 3 may be used to communicate about and monitor minor security threats. A user may monitor all three channels by using a two way radio having a scanning mode. However, the user is limited to transmitting on the most recently scanned channel. If the user fails to transmit within a short predetermined period of time, the two way radio may scan to a new channel. The user then needs to manually select the channel, wasting valuable time and eliminating the ability to scan other channels during the selection process.

[0002] Other devices that can be used instead of two way radios include cellular telephones. These devices have revolutionized personal communication by allowing telephone access from anywhere within reach of wireless network infrastructure (e.g., cellular networks, communication satellites, or other infrastructure of other wireless networks adapted for voice communications). In as much as the use of handheld wireless voice communication devices is not restricted to homes and offices, such devices will often be used in environments where there is considerable ambient noise. Examples of such environments include busy urban settings, inside moving vehicles and on factory floors. Ambient noise in an environment can degrade the intelligibility of received voice audio and thereby interfere with users' ability to communicate.

[0003] United States Patent 20060270467 discusses enhancing the intelligibility of speech emitted into a noisy environment by filtering ambient noise with a filter that simulates the physical blocking of noise by at least a part of a voice communication device and determining a frequency dependent SNR of received voice audio relative to ambient noise is computed on a perceptual (e.g. Bark) frequency scale. Formants are identified and the SNR in bands including certain formants are modified with formant enhancement gain factors in order to improve intelligibility. However, in certain industrial, emergency, government and military applications, such noise filtering is insufficient to provide high quality, hands-free, yet inconspicuous communication capability for field personnel.

SUMMARY

[0004] Methods and apparatus that support communications and/or medical information monitoring for field personnel are disclosed. In one embodiment, a device provides an electronic and transducer device that can be attached, adhered, or otherwise embedded into or upon a removable oral appliance or other oral device to form a two-way communication assembly.

[0005] In another embodiment, the device provides an electronic and transducer device that can be attached, adhered, or otherwise embedded into or upon a removable oral appliance or other oral device to form a medical tag containing patient identifiable information. Such an oral appliance may be a custom-made device fabricated from a thermal forming process utilizing a replicate model of a dental structure obtained by conventional dental impression and/or imaging methods. The electronic and transducer assembly may receive incoming sounds either directly or through a receiver to process and amplify the signals and transmit the processed sounds via a vibrating transducer element coupled to a tooth or other bone structure, such as the maxillary, mandibular, or palatine bone structure.

[0006] Advantages of preferred embodiments may include one or more of the following. The system is a multi-purpose communication platform that is rugged, wireless and secure. The system provides quality, hands-free, yet inconspicuous communication capability for field personnel. In embodiments that support voice and data from the field, the system automates the capture and transfer of data in the field to a central remote computer for further processing. By minimizing human data collection, the system reduces paperwork, allows for the collection of more complete field information, eliminates redundant data entry, and increases responsiveness to fluid situations present in industrial environment or emergency, local government or military incidents.

[0007] For applications that require health monitoring, the system enables healthcare providers to make certain all patient episodes are captured and recorded no matter the environment. Most importantly, the system provides a standard of care to field personnel by providing access to previously unavailable information. For military and emergency applications, the system provides commanders with real time visibility of their readiness status and provides support for medical command and control, telemedicine and medical informatics applications across the continuum of the spectrum of military medical operations but especially for the first responder and far forward medical facilities. With soldiers deployed in many different parts of the world, the system allows medical professionals to capture patient episodes anywhere, anytime, and ensure complete patient information is recorded and transferred to the soldier's medical records at home. Additionally, the system

provides a dental identification capability which is retained on the individual and thus is less subject to destruction, loss, forgetfulness, or any of numerous other problems.

BRIEF DESCRIPTION OF THE DRAWINGS

[0008] Figs. 1A-1C shows exemplary two way communication devices.

[0009] Fig. 1D illustrates the dentition of a patient's teeth and one variation of a two-way communication device which is removably placed upon or against the patient's tooth or teeth as a removable oral appliance.

[0010] Fig. 2A illustrates a perspective view of the lower teeth showing one exemplary location for placement of the removable oral appliance two-way communication device.

[0011] Fig. 2B illustrates another variation of the removable oral appliance in the form of an appliance which is placed over an entire row of teeth in the manner of a mouthguard.

[0012] Fig. 2C illustrates another variation of the removable oral appliance which is supported by an arch.

[0013] Fig. 2D illustrates another variation of an oral appliance configured as a mouthguard.

[0014] Fig. 3 illustrates a detail perspective view of the oral appliance positioned upon the patient's teeth utilizable in combination with a transmitting assembly external to the mouth and wearable by the patient in another variation of the device.

[0015] Fig. 4 shows an illustrative configuration of the individual components in a variation of the oral appliance device having an external transmitting assembly with a receiving and transducer assembly within the mouth.

[0016] Fig. 5 shows an illustrative configuration of another variation of the device in which the entire assembly is contained by the oral appliance within the user's mouth.

[0017] Fig. 6A shows a partial cross-sectional view of an oral appliance placed upon a tooth with an electronics/transducer assembly adhered to the tooth surface via an adhesive.

[0018] Fig. 6B shows a partial cross-sectional view of a removable backing adhered onto an adhesive surface.

[0019] Fig. 7 shows a partial cross-sectional view of another variation of an oral appliance placed upon a tooth with an electronics/transducer assembly pressed against the tooth surface via an osmotic pouch.

[0020] Fig. 8 shows a partial cross-sectional view of another variation of an oral appliance placed upon a tooth with an electronics/transducer assembly pressed against the tooth surface via one or more biasing elements.

[0021] Fig. 9 illustrates another variation of an oral appliance having an electronics assembly and a transducer assembly separated from one another within the electronics and transducer housing of the oral appliance.

[0022] Figs. 10 and 11 illustrate additional variations of oral appliances in which the electronics and transducer assembly are maintainable against the tooth surface via a ramped surface and a biasing element.

[0023] Fig. 12 shows yet another variation of an oral appliance having an interfacing member positioned between the electronics and/or transducer assembly and the tooth surface.

[0024] Fig. 13 shows yet another variation of an oral appliance having an actuatable mechanism for urging the electronics and/or transducer assembly against the tooth surface.

[0025] Fig. 14 shows yet another variation of an oral appliance having a cam mechanism for urging the electronics and/or transducer assembly against the tooth surface.

[0026] Fig. 15 shows yet another variation of an oral appliance having a separate transducer mechanism positionable upon the occlusal surface of the tooth for transmitting vibrations.

[0027] Fig. 16 illustrates another variation of an oral appliance having a mechanism for urging the electronics and/or transducer assembly against the tooth surface utilizing a bite-actuated mechanism.

[0028] Fig. 17 shows yet another variation of an oral appliance having a composite dental anchor for coupling the transducer to the tooth.

[0029] Figs. 18A and 18B show side and top views, respectively, of an oral appliance variation having one or more transducers which may be positioned over the occlusal surface of the tooth.

[0030] Figs. 19A and 19B illustrate yet another variation of an oral appliance made from a shape memory material in its pre-formed relaxed configuration and its deformed configuration when placed over or upon the patient's tooth, respectively, to create an interference fit.

[0031] Fig. 20 illustrates yet another variation of an oral appliance made from a pre-formed material in which the transducer may be positioned between the biased side of the oral appliance and the tooth surface.

[0032] Fig. 21 illustrates a variation in which the oral appliance may be omitted and the electronics and/or transducer assembly may be attached to a composite dental anchor attached directly to the tooth surface.

[0033] Figs. 22A and 22B show partial cross-sectional side and perspective views, respectively, of another variation of an oral appliance assembly having its occlusal surface removed or omitted for patient comfort.

[0034] Figs. 23A and 23B illustrate perspective and side views, respectively, of an oral appliance which may be coupled to a screw or post implanted directly into the underlying bone, such as the maxillary or mandibular bone.

[0035] Fig. 24 illustrates another variation in which the oral appliance may be coupled to a screw or post implanted directly into the palate of a patient.

[0036] Figs. 25A and 25B illustrate perspective and side views, respectively, of an oral appliance which may have its transducer assembly or a coupling member attached to the gingival surface to conduct vibrations through the gingival tissue and underlying bone.

[0037] Fig. 26 illustrates an example of how multiple oral appliance two-way communication assemblies or transducers may be placed on multiple teeth throughout the patient's mouth.

[0038] Figs. 27A and 27B illustrate perspective and side views, respectively, of an oral appliance (similar to a variation shown above) which may have a microphone unit positioned adjacent to or upon the gingival surface to physically separate the microphone from the transducer to attenuate or eliminate feedback.

[0039] Fig. 28 illustrates another variation of a removable oral appliance supported by an arch and having a microphone unit integrated within the arch.

[0040] Fig. 29 shows yet another variation illustrating at least one microphone and optionally additional microphone units positioned around the user's mouth and in wireless communication with the electronics and/or transducer assembly.

DESCRIPTION

[0041] As shown in the embodiment of Fig. 1A, a two way communication system 1 includes a mouth wearable communicator 6, one or more body sensors 2, and a linking unit 3 coupled to the mouth wearable communicator and the one or more body sensors, the linking unit adapted to communicate with a remote station. The mouth wearable communicator can include a bone conduction hearing system to transmit sound to the user, and the communicator can have an embedded microphone to pick up sound. The mouth wearable communicator can be a custom oral device. One or more medical sensors can be embedded therein to pick up vital sign information. Alternatively, environmental sensors such as room temperature sensors can be used to sense parameters from the environment and/or the room, for example. Vital sign can include certain body physiological signal measurements while environmental signals may be of interest in fire fighting and other similar cases. The environment temperature sensor can be provided in the linking unit 3 or other devices attached or close to body. Also there are some other signals beside listed that can be picked from linking unit 3 or even the mouth wearable communicator 6 that may be of great value. For example "Location (using GPS or cell phone signals or equivalent method)", "Speed", "Acceleration", "Shock", "Smoke", "Light", "Infra Red", "Radiation" and "Wind Speed" can help identify the location of a Fire Fighter or Miner, and to assess if he or she is at risk. The mouth wearable communicator can provide a data storage device such as a solid state memory or a flash storage device. The content of the the data storage device can be encrypted for security. A local transceiver can connect the mouth wearable communicator 6 with the one or more body sensors 2 and the linking unit 3. The local transceiver can transmit encrypted data for secure transmission if desired. A wireless local area network (LAN) or a wired LAN can support communications among the mouth wearable communicator 6 with the one or more body sensors 2 and the linking unit 3. The LAN forms a body link among sensors 2, mouth piece 1 and the linking unit or device 3. The linking unit 3 can communicate over a wide area network (WAN) to the remote station 5. The remote station can be a satellite, a cellular tower, a relay station mounted on an airplane or a helicopter, or a relay station mounted on a blimp, among others.

[0042] A beacon 4 can be positioned on the user's body and communicate with the mouth wearable communicator 6 to identify that the user is in need of assistance. The beacon 4 can provide an audible signal, a location signal, a visible signal to request assistance. The beacon 4 can be affixed to a first responder's uniform and can be activated if the user's vital signs indicate he/she has been hurt and can help to locate them in a smoky environment.

[0043] The two way communication device can use the body sensor 2 to sense a vital sign or a measured parameter such as environment temperature, among others. The vital sign can

include body temperature, hydration, heart rate, EKG, EEG, pulse rate, oxygen saturation, respiratory cycle, air flow velocity, potential of hydrogen (pH) level, for example. The measured parameter can include environment temperature. The sensor can be positioned in the linking unit 3 or other devices attached or close to body. Also other measured parameter signals that can be picked from the linking unit 3 or the mouth piece 6 that may be of value, including "Location (using GPS or cell phone signals or equivalent method)", "Speed", "Acceleration", "Shock", "Smoke", "Light", "Infra Red", "Radiation" and "Wind Speed." The measure parameters can help identify the location of a Fire Fighter or Miner, and to assess if he or she is at risk, for example. The body sensor 2 can also include an activity monitor. For instance accelerometers can monitor whether the subject is moving, walking or running and relay the information to the remote station 5.

[0044] The two way communication device can have a microphone to pick up sound. The microphone can be an intraoral microphone or an extraoral microphone. In one embodiment, the microphone cancels environmental noise and transmits a user's voice to the remote station. This embodiment provides the ability to cancel environmental noises while transmitting subject's own voice to the remote station 5 such as a call center. As the microphone is in a fixed location (compared to ordinary wireless communication devices) and very close to user's own voice, the system can handle environmental noise reduction that is important in working in high noise areas. As such, the two way communication device can be used by workers in loud environments such as a professional entertainer or athlete and/or support personnel, a soldier, a medic, a fireman, an emergency worker, among others.

[0045] The two way communication device can provide a wireless sensor network that communicates with the mouth wearable communicator 6, the one or more body sensors 2, and the linking unit 3. In other embodiments, the linking unit 3 wirelessly communicates with other linking units of other users to form a wireless local area network for detection, identification and communication with a crew.

[0046] In one embodiment, the mouth wearable communicator 6 has a housing having a shape which is conformable to at least a portion of at least one tooth; an actuatable transducer disposed within or upon the housing and in vibratory communication with a surface of the at least one tooth; and a wireless communication transceiver coupled to the transducer to provide received sound to the user and to provide communication for the user. The two way communication device can be an oral appliance having a shape which conforms to the at least one tooth. An electronic assembly can be disposed within or upon the housing and which is in communication with the transducer.

[0047] In another aspect, a method for providing two way communication includes intraorally wearing a mouth wearable communicator; sensing one or more body parameters or

environmental parameters; and linking to the mouth wearable communicator and the one or more body sensors to a remote station.

[0048] Implementations of the above method can include one or more of the following. The system can transmit sound using a bone conduction device. The mouth wearable communicator can be a custom oral device. The system can embed one or more sensors in the mouth wearable communicator. The system can store medical or environmental data in the mouth wearable communicator. For emergency or military users that may face danger, the system can store data in the mouth wearable communicator as a secured black box device for subsequent forensic analysis.

[0049] Turning now to Figs. 1B-1C, exemplary usage scenarios are shown. As shown in FIG. 1B, an industrial user is shown using the two way communication device. As shown in Fig. 1C, an exemplary two way communication device and/or medical monitoring device 1 is shown for military applications. In one embodiment, the device 1 provides an electronic and transducer device that can be attached, adhered, or otherwise embedded into or upon a removable oral appliance or other oral device to form a two-way communication assembly. As shown in Figs. 1B-1C, the device can be used by emergency and security personnel, medical personnel, municipal workers, industrial plant workers, individuals in loud environments that require communications (musicians, athletes and their support personnel), and the military, among others.

[0050] In another embodiment, the device 1 provides an electronic and transducer device 4 that can be attached, adhered, or otherwise embedded into or upon a removable oral appliance or other oral device to form a medical tag containing patient identifiable information. Such an oral appliance may be a custom-made device fabricated from a thermal forming process utilizing a replicate model of a dental structure obtained by conventional dental impression methods. The electronic and transducer assembly may receive incoming sounds either directly or through a receiver to process and amplify the signals and transmit the processed sounds via a vibrating transducer element coupled to a tooth or other bone structure, such as the maxillary, mandibular, or palatine bone structure.

[0051] The device 1 can include sensors that detect chemicals present in the user's saliva and provide medical information on the user. The device 1 can also sense heart rate, EKG, and other bio-signals that can be picked up within the mouth. Additionally, the device 1 can communicate with a medical data collection module 2 that can collect vital signs such as temperature, heart rate, EKG, respiration rate, and other vital signs or medical information. The device 1 can communicate with the module 2 through various short range radios such as a Bluetooth radio, for example.

[0052] The device 1 can also communicate through a long range transceiver such as a short-wave transceiver, a cellular telephone transceiver, or a satellite transceiver 3. Such transceivers can be provided within the device 1, or alternatively, can be body worn. In the embodiment of Fig. 1, a cellular or satellite transceiver 3 is positioned on a belt worn by the user. The transceiver 3 communicates with the other devices on the user's body through the short range radio such as Bluetooth, for example.

[0053] An exemplary process to collect medical information from the user (such as fire fighting personnel) and for supporting bone-conduction two way communication can be as follows:

Periodically collect vital sign and other medical information

Check to see if the user is using the long range transceiver for talking

If long range transceiver is not used for talking, upload medical history of the user to a remote computer over the long range transceiver

Remote computer detects if the medical data falls outside of an acceptable range that requires medical intervention

Alarm sound is generated to the user alerting him/her that there is a potential problem and that he/she should contact Command post

If medical intervention is required, the remote computer alerts the user's commander for action to assist the user

Self-help instructions can be sent through the transceiver 3 to the bone conduction communication device 1

[0054] In one embodiment, the medical data would include user identification, triage status, condition, and treatment. The data would be routed via a cellular transceiver or a satellite transceiver to a Command Post where it is processed, stored, relayed to the Internet, and moved back to devices on the field. As a result, data on casualties would be accessible immediately for operational use by other users, medics, responders, incident commanders and even receiving hospitals that can help the user. Real-time information regarding victims and their status is critical to the overall management of field medical care. Medical command can then coordinate timely information on the number of casualties and their needs with the known availability of resources, such as on-scene providers, ambulance locations, and area hospital capacities. Real-time information is also provided for determining the appropriate patient destination, depending on the type of injuries and the capabilities of the receiving facilities.

[0055] An exemplary process to collect work information from a plant or site and for supporting bone-conduction two way communication with the worker can be as follows:

Periodically collect plant or industrial parameters

Check to see if the user is using the long range transceiver for talking

If long range transceiver is not used for talking, upload the industrial parameters collected by the user to a remote computer over the long range transceiver

Remote computer detects if the collected data falls outside of an acceptable range that requires intervention

If intervention is required, the remote computer alerts the user's supervisor for action and also activate a beacon mounted on the user to help identify his/her location in case of smoke or other issues that could hamper visibility

Corrective instructions can be sent through the transceiver to the bone conduction communication device 1 so that user can fix problem at the site

[0056] In another embodiment for military use, the remote computer can support a BATTLEFIELD MEDICAL INFORMATION SYSTEMS TACTICAL-JOINT (BMIST-J) for enabling military providers to record, store, retrieve and transfer medical records to the DoD's Clinical Data Repository by synchronizing the received data. The system supports digital versions of the DD 1380 (field medical card) and SF 600 (chronological medical record of care). Diagnostic and treatment decision aids are provided by the system. The data captured by the device 1 is also Personal Information Carrier (PIC) compatible. The system provides a secure, legible, electronic records of battlefield treatments, contributes to a comprehensive, life-long medical history, and facilitates medical surveillance. This device can also help medical personnel to triage soldiers more effectively by noting vital signs and ranking accordingly.

[0057] Turning now to more details on the device 1, as shown in Fig. 1D, a patient's mouth and dentition 10 is illustrated showing one possible location for removably attaching two-way communication assembly 14 upon or against at least one tooth, such as a molar 12. The patient's tongue TG and palate PL are also illustrated for reference. An electronics and/or transducer assembly 16 may be attached, adhered, or otherwise embedded into or upon the assembly 14, as described below in further detail.

[0058] Fig. 2A shows a perspective view of the patient's lower dentition illustrating the two-way communication assembly 14 comprising a removable oral appliance 18 and the electronics and/or transducer assembly 16 positioned along a side surface of the assembly 14. In this variation, oral appliance 18 may be fitted upon two molars 12 within tooth engaging channel 20 defined by oral appliance 18 for stability upon the patient's teeth, although in other variations, a single molar or tooth may be utilized. Alternatively, more than two molars may be utilized for the oral appliance 18 to be attached upon or over. Moreover, electronics and/or transducer assembly 16 is shown positioned upon a side surface of oral appliance 18 such that the assembly 16 is aligned along a buccal surface of the tooth 12; however, other

surfaces such as the lingual surface of the tooth 12 and other positions may also be utilized. The figures are illustrative of variations and are not intended to be limiting; accordingly, other configurations and shapes for oral appliance 18 are intended to be included herein.

[0059] Fig. 2B shows another variation of a removable oral appliance in the form of an appliance 15 which is placed over an entire row of teeth in the manner of a mouthguard. In this variation, appliance 15 may be configured to cover an entire bottom row of teeth or alternatively an entire upper row of teeth. In additional variations, rather than covering the entire rows of teeth, a majority of the row of teeth may be instead be covered by appliance 15. Assembly 16 may be positioned along one or more portions of the oral appliance 15.

[0060] Fig. 2C shows yet another variation of an oral appliance 17 having an arched configuration. In this appliance, one or more tooth retaining portions 21, 23, which in this variation may be placed along the upper row of teeth, may be supported by an arch 19 which may lie adjacent or along the palate of the user. As shown, electronics and/or transducer assembly 16 may be positioned along one or more portions of the tooth retaining portions 21, 23. Moreover, although the variation shown illustrates an arch 19 which may cover only a portion of the palate of the user, other variations may be configured to have an arch which covers the entire palate of the user.

[0061] Fig. 2D illustrates yet another variation of an oral appliance in the form of a mouthguard or retainer 25 which may be inserted and removed easily from the user's mouth. Such a mouthguard or retainer 25 may be used in sports where conventional mouthguards are worn; however, mouthguard or retainer 25 having assembly 16 integrated therein may be utilized by persons, hearing impaired or otherwise, who may simply hold the mouthguard or retainer 25 via grooves or channels 26 between their teeth for receiving instructions remotely and communicating over a distance.

[0062] Generally, the volume of electronics and/or transducer assembly 16 may be minimized so as to be unobtrusive and as comfortable to the user when placed in the mouth. Although the size may be varied, a volume of assembly 16 may be less than 800 cubic millimeters. This volume is, of course, illustrative and not limiting as size and volume of assembly 16 and may be varied accordingly between different users.

[0063] Moreover, removable oral appliance 18 may be fabricated from various polymeric or a combination of polymeric and metallic materials using any number of methods, such as computer-aided machining processes using computer numerical control (CNC) systems or three-dimensional printing processes, e.g., stereolithography apparatus (SLA), selective laser sintering (SLS), and/or other similar processes utilizing three-dimensional geometry of the patient's dentition, which may be obtained via any number of techniques. Such techniques may include use of scanned dentition using intra-oral scanners such as laser, white light,

ultrasound, mechanical three-dimensional touch scanners, magnetic resonance imaging (MRI), computed tomography (CT), other optical methods, etc.

[0064] In forming the removable oral appliance 18, the appliance 18 may be optionally formed such that it is molded to fit over the dentition and at least a portion of the adjacent gingival tissue to inhibit the entry of food, fluids, and other debris into the oral appliance 18 and between the transducer assembly and tooth surface. Moreover, the greater surface area of the oral appliance 18 may facilitate the placement and configuration of the assembly 16 onto the appliance 18.

[0065] Additionally, the removable oral appliance 18 may be optionally fabricated to have a shrinkage factor such that when placed onto the dentition, oral appliance 18 may be configured to securely grab onto the tooth or teeth as the appliance 18 may have a resulting size slightly smaller than the scanned tooth or teeth upon which the appliance 18 was formed. The fitting may result in a secure interference fit between the appliance 18 and underlying dentition.

[0066] In one variation, with assembly 14 positioned upon the teeth, as shown in Fig. 3, an extra-buccal transmitter assembly 22 located outside the patient's mouth may be utilized to receive auditory signals for processing and transmission via a wireless signal 24 to the electronics and/or transducer assembly 16 positioned within the patient's mouth, which may then process and transmit the processed auditory signals via vibratory conductance to the underlying tooth and consequently to the patient's inner ear.

[0067] The transmitter assembly 22, as described in further detail below, may contain a microphone assembly as well as a transmitter assembly and may be configured in any number of shapes and forms worn by the user, such as a watch, necklace, lapel, phone, belt-mounted device, etc.

[0068] Fig. 4 illustrates a schematic representation of one variation of two-way communication assembly 14 utilizing an extra-buccal transmitter assembly 22, which may generally comprise microphone 30 for receiving sounds and which is electrically connected to processor 32 for processing the auditory signals. Processor 32 may be connected electrically to transmitter 34 for transmitting the processed signals to the electronics and/or transducer assembly 16 disposed upon or adjacent to the user's teeth. The microphone 30 and processor 32 may be configured to detect and process auditory signals in any practicable range, but may be configured in one variation to detect auditory signals ranging from, e.g., 250 Hertz to 20,000 Hertz.

[0069] With respect to microphone 30, a variety of various microphone systems may be utilized. For instance, microphone 30 may be a digital, analog, and/or directional type

microphone. Such various types of microphones may be interchangeably configured to be utilized with the assembly, if so desired.

[0070] Power supply 36 may be connected to each of the components in transmitter assembly 22 to provide power thereto. The transmitter signals 24 may be in any wireless form utilizing, e.g., radio frequency, ultrasound, microwave, Blue Tooth® (BLUETOOTH SIG, INC., Bellevue, WA), etc. for transmission to assembly 16. Assembly 22 may also optionally include one or more input controls 28 that a user may manipulate to adjust various acoustic parameters of the electronics and/or transducer assembly 16, such as acoustic focusing, volume control, filtration, muting, frequency optimization, sound adjustments, and tone adjustments, etc.

[0071] The signals transmitted 24 by transmitter 34 may be received by electronics and/or transducer assembly 16 via receiver 38, which may be connected to an internal processor for additional processing of the received signals. The received signals may be communicated to transducer 40, which may vibrate correspondingly against a surface of the tooth to conduct the vibratory signals through the tooth and bone and subsequently to the middle ear to facilitate hearing of the user. Transducer 40 may be configured as any number of different vibratory mechanisms. For instance, in one variation, transducer 40 may be an electromagnetically actuated transducer. In other variations, transducer 40 may be in the form of a piezoelectric crystal having a range of vibratory frequencies, e.g., between 250 to 4000 Hz.

[0072] Power supply 42 may also be included with assembly 16 to provide power to the receiver, transducer, and/or processor, if also included. Although power supply 42 may be a simple battery, replaceable or permanent, other variations may include a power supply 42 which is charged by inductance via an external charger. Additionally, power supply 42 may alternatively be charged via direct coupling to an alternating current (AC) or direct current (DC) source. Other variations may include a power supply 42 which is charged via a mechanical mechanism, such as an internal pendulum or slidable electrical inductance charger as known in the art, which is actuated via, e.g., motions of the jaw and/or movement for translating the mechanical motion into stored electrical energy for charging power supply 42.

[0073] In another variation of assembly 16, rather than utilizing an extra-buccal transmitter, two-way communication assembly 50 may be configured as an independent assembly contained entirely within the user's mouth, as shown in Fig. 5. Accordingly, assembly 50 may include an internal microphone 52 in communication with an on-board processor 54. Internal microphone 52 may comprise any number of different types of microphones, as described above. Processor 54 may be used to process any received auditory signals for

filtering and/or amplifying the signals and transmitting them to transducer 56, which is in vibratory contact against the tooth surface. Power supply 58, as described above, may also be included within assembly 50 for providing power to each of the components of assembly 50 as necessary.

[0074] In order to transmit the vibrations corresponding to the received auditory signals efficiently and with minimal loss to the tooth or teeth, secure mechanical contact between the transducer and the tooth is ideally maintained to ensure efficient vibratory communication. Accordingly, any number of mechanisms may be utilized to maintain this vibratory communication.

[0075] In one variation as shown in Fig. 6A, a partial cross-sectional view of a removable oral appliance 60 is shown placed over or upon a tooth TH. Electronics and/or transducer housing 62 may be seen defined along oral appliance 60 such that housing 62 is aligned or positioned adjacent to a side surface, buccal and/or lingual surface, of the tooth TH. Housing 62 may provide protection to the electronics and/or transducer assembly from the environment of the mouth.

[0076] An electronics and/or transducer assembly 64 may be simply placed, embedded, or encapsulated within housing 62 for contacting the tooth surface. In this variation, assembly 64 may be adhered against the tooth surface via an adhesive surface or film 66 such that contact is maintained between the two. As shown in Fig. 6B, a removable backing 68 may be adhered onto adhesive surface 66 and removed prior to placement upon the tooth surface. In this manner, assembly 64 may be replaced upon the tooth as necessary with additional electronics and/or transducer assemblies.

[0077] Aside from an adhesive film 66, another alternative may utilize an expandable or swellable member to ensure a secure mechanical contact of the transducer against the tooth. As shown in Fig. 7, an osmotic patch or expandable hydrogel 74 may be placed between housing 62 and electronics and/or transducer assembly 72. After placement of oral appliance 60, hydrogel 74 may absorb some fluids, either from any surrounding fluid or from a fluid introduced into hydrogel 74, such that hydrogel 74 expands in size to force assembly 72 into contact against the tooth surface. Assembly 72 may be configured to define a contact surface 70 having a relatively smaller contact area to facilitate uniform contact of the surface 70 against the tooth. Such a contact surface 70 may be included in any of the variations described herein. Additionally, a thin encapsulating layer or surface 76 may be placed over housing 62 between contact surface 70 and the underlying tooth to prevent any debris or additional fluids from entering housing 62.

[0078] Another variation is shown in Fig. 8, which shows electronics and/or transducer assembly 80 contained within housing 62. In this variation, one or more biasing elements 82,

e.g., springs, pre-formed shape memory elements, etc., may be placed between assembly 80 and housing 62 to provide a pressing force on assembly 80 to urge the device against the underlying tooth surface, thereby ensuring mechanical contact.

[0079] In yet another variation, the electronics may be contained as a separate assembly 90 which is encapsulated within housing 62 and the transducer 92 may be maintained separately from assembly 90 but also within housing 62. As shown in Fig. 9, transducer 92 may be urged against the tooth surface via a spring or other biasing element 94 and actuated via any of the mechanisms described above.

[0080] In other variations as shown in Fig. 10, electronics and/or transducer assembly 100 may be configured to have a ramped surface 102 in apposition to the tooth surface. The surface 102 may be angled away from the occlusal surface of the tooth. The assembly 100 may be urged via a biasing element or spring 106 which forces the ramped surface 102 to pivot about a location 104 into contact against the tooth to ensure contact for the transducer against the tooth surface.

[0081] Fig. 11 illustrates another similar variation in electronics and/or transducer assembly 110 also having a ramped surface 112 in apposition to the tooth surface. In this variation, the ramped surface 112 may be angled towards the occlusal surface of the tooth. Likewise, assembly 110 may be urged via a biasing element or spring 116 which urges the assembly 110 to pivot about its lower end such that the assembly 110 contacts the tooth surface at a region 114.

[0082] In yet another variation shown in Fig. 12, electronics and/or transducer assembly 120 may be positioned within housing 62 with an interface layer 122 positioned between the assembly 120 and the tooth surface. Interface layer 122 may be configured to conform against the tooth surface and against assembly 120 such that vibrations may be transmitted through layer 122 and to the tooth in a uniform manner. Accordingly, interface layer 122 may be made from a material which attenuates vibrations minimally. Interface layer 122 may be made in a variety of forms, such as a simple insert, an O-ring configuration, etc. or even in a gel or paste form, such as denture or oral paste, etc. Additionally, layer 122 may be fabricated from various materials, e.g., hard plastics or polymeric materials, metals, etc.

[0083] Fig. 13 illustrates yet another variation in which electronics and/or transducer assembly 130 may be urged against the tooth surface via a mechanical mechanism. As shown, assembly 130 may be attached to a structural member 132, e.g., a threaded member or a simple shaft, which is connected through housing 62 to an engagement member 134 located outside housing 62. The user may rotate engagement member 134 (as indicated by rotational arrow 136) or simply push upon member 134 (as indicated by linear arrow 138) to urge assembly 130 into contact against the tooth. Moreover, actuation of engagement member 134

may be accomplished manually within the mouth or through the user's cheek or even through manipulation via the user's tongue against engagement member 134.

[0084] Another variation for a mechanical mechanism is illustrated in Fig. 14. In this variation, electronics and/or transducer assembly 140 may define a portion as an engaging surface 142 for contacting against a cam or lever mechanism 144. Cam or lever mechanism 144 may be configured to pivot 146 such that actuation of a lever 148 extending through housing 62 may urge cam or lever mechanism 144 to push against engaging surface 142 such that assembly 140 is pressed against the underlying tooth surface.

[0085] In yet another variation, the electronics 150 and the transducer 152 may be separated from one another such that electronics 150 remain disposed within housing 62 but transducer 152, connected via wire 154, is located beneath dental oral appliance 60 along an occlusal surface of the tooth, as shown in Fig. 15. In such a configuration, vibrations are transmitted via the transducer 152 through the occlusal surface of the tooth. Additionally, the user may bite down upon the oral appliance 60 and transducer 152 to mechanically compress the transducer 152 against the occlusal surface to further enhance the mechanical contact between the transducer 152 and underlying tooth to further facilitate transmission therethrough.

[0086] In the variation of Fig. 16, another example for a bite-enhanced coupling mechanism is illustrated where electronics and/or transducer assembly 160 defines an angled interface surface 162 in apposition to a correspondingly angled engaging member 164. A proximal end of engaging member 164 may extend through housing 62 and terminate in a pusher member 166 positioned over an occlusal surface of the tooth TH. Once oral appliance 60 is initially placed over tooth TH, the user may bite down or otherwise press down upon the top portion of oral appliance 60, thereby pressing down upon pusher member 166 which in turn pushes down upon engaging member 164, as indicated by the arrow. As engaging member 164 is urged downwardly towards the gums, its angled surface may push upon the corresponding and oppositely angled surface 162 to urge assembly 160 against the tooth surface and into a secure mechanical contact.

[0087] In yet another variation, an electronics and/or transducer assembly 170 may define a channel or groove 172 along a surface for engaging a corresponding dental anchor 174, as shown in Fig. 17. Dental anchor 174 may comprise a light-curable acrylate-based composite material adhered directly to the tooth surface. Moreover dental anchor 174 may be configured in a shape which corresponds to a shape of channel or groove 172 such that the two may be interfitted in a mating engagement. In this manner, the transducer in assembly 170 may vibrate directly against dental anchor 174 which may then transmit these signals directly into the tooth TH.

[0088] Figs. 18A and 18B show partial cross-sectional side and top views, respectively, of another variation in which oral appliance 180 may define a number of channels or grooves 184 along a top portion of oral appliance 180. Within these channels or grooves 184, one or more transducers 182, 186, 188, 190 may be disposed such that they are in contact with the occlusal surface of the tooth and each of these transducers may be tuned to transmit frequencies uniformly. Alternatively, each of these transducers may be tuned to transmit only at specified frequency ranges. Accordingly, each transducer can be programmed or preset for a different frequency response such that each transducer may be optimized for a different frequency response and/or transmission to deliver a relatively high-fidelity sound to the user.

[0089] In yet another variation, Figs. 19A and 19B illustrate an oral appliance 200 which may be pre-formed from a shape memory polymer or alloy or a superelastic material such as a Nickel-Titanium alloy, e.g., Nitinol. Fig. 19A shows oral appliance 200 in a first configuration where members 202, 204 are in an unbiased memory configuration. When placed upon or against the tooth TH, members 202, 204 may be deflected into a second configuration where members 202', 204' are deformed to engage tooth TH in a secure interference fit, as shown in Fig. 19B. The biased member 204' may be utilized to press the electronics and/or transducer assembly contained therein against the tooth surface as well as to maintain securement of the oral appliance 200 upon the tooth TH.

[0090] Similarly, as shown in Fig. 20, removable oral appliance 210 may have biased members to secure engage the tooth TH, as above. In this variation, the ends of the members 212, 214 may be configured into curved portions under which a transducer element 218 coupled to electronics assembly 216 may be wedged or otherwise secured to ensure mechanical contact against the tooth surface.

[0091] Fig. 21 shows yet another variation in which the oral appliance is omitted entirely. Here, a composite dental anchor or bracket 226, as described above, may be adhered directly onto the tooth surface. Alternatively, bracket 226 may be comprised of a biocompatible material, e.g., stainless steel, Nickel-Titanium, Nickel, ceramics, composites, etc., formed into a bracket and anchored onto the tooth surface. The bracket 226 may be configured to have a shape 228 over which an electronics and/or transducer assembly 220 may be slid over or upon via a channel 222 having a corresponding receiving configuration 224 for engagement with bracket 226. In this manner, assembly 220 may be directly engaged against bracket 226, through which a transducer may directly vibrate into the underlying tooth TH. Additionally, in the event that assembly 220 is removed from the tooth TH, assembly 220 may be simply slid or rotated off bracket 226 and a replacement assembly may be put in its place upon bracket 226.

[0092] Figs. 22A and 22B show partial cross-sectional side and perspective views, respectively, of yet another variation of an oral appliance 230. In this variation, the oral appliance 230 may be configured to omit an occlusal surface portion of the oral appliance 230 and instead engages the side surfaces of the tooth TH, such as the lingual and buccal surfaces only. The electronics and/or transducer assembly 234 may be contained, as above, within a housing 232 for contact against the tooth surface. Additionally, as shown in Fig. 22B, one or more optional cross-members 236 may connect the side portions of the oral appliance 230 to provide some structural stability when placed upon the tooth. This variation may define an occlusal surface opening 238 such that when placed upon the tooth, the user may freely bite down directly upon the natural occlusal surface of the tooth unobstructed by the oral appliance device, thereby providing for enhanced comfort to the user.

[0093] In yet other variations, vibrations may be transmitted directly into the underlying bone or tissue structures rather than transmitting directly through the tooth or teeth of the user. As shown in Fig. 23A, an oral appliance 240 is illustrated positioned upon the user's tooth, in this example upon a molar located along the upper row of teeth. The electronics and/or transducer assembly 242 is shown as being located along the buccal surface of the tooth. Rather than utilizing a transducer in contact with the tooth surface, a conduction transmission member 244, such as a rigid or solid metallic member, may be coupled to the transducer in assembly 242 and extend from oral appliance 240 to a post or screw 246 which is implanted directly into the underlying bone 248, such as the maxillary bone, as shown in the partial cross-sectional view of Fig. 23B. As the distal end of transmission member 244 is coupled directly to post or screw 246, the vibrations generated by the transducer may be transmitted through transmission member 244 and directly into post or screw 246, which in turn transmits the vibrations directly into and through the bone 248 for transmission to the user's inner ear.

[0094] Fig. 24 illustrates a partial cross-sectional view of an oral appliance 250 placed upon the user's tooth TH with the electronics and/or transducer assembly 252 located along the lingual surface of the tooth. Similarly, the vibrations may be transmitted through the conduction transmission member 244 and directly into post or screw 246, which in this example is implanted into the palatine bone PL. Other variations may utilize this arrangement located along the lower row of teeth for transmission to a post or screw 246 drilled into the mandibular bone.

[0095] In yet another variation, rather utilizing a post or screw drilled into the underlying bone itself, a transducer may be attached, coupled, or otherwise adhered directly to the gingival tissue surface adjacent to the teeth. As shown in Figs. 25A and 25B, an oral appliance 260 may have an electronics assembly 262 positioned along its side with an

electrical wire 264 extending therefrom to a transducer assembly 266 attached to the gingival tissue surface 268 next to the tooth TH. Transducer assembly 266 may be attached to the tissue surface 268 via an adhesive, structural support arm extending from oral appliance 260, a dental screw or post, or any other structural mechanism. In use, the transducer may vibrate and transmit directly into the underlying gingival tissue, which may conduct the signals to the underlying bone.

[0096] For any of the variations described above, they may be utilized as a single device or in combination with any other variation herein, as practicable, to achieve the desired hearing level in the user. Moreover, more than one oral appliance device and electronics and/or transducer assemblies may be utilized at any one time. For example, Fig. 26 illustrates one example where multiple transducer assemblies 270, 272, 274, 276 may be placed on multiple teeth. Although shown on the lower row of teeth, multiple assemblies may alternatively be positioned and located along the upper row of teeth or both rows as well. Moreover, each of the assemblies may be configured to transmit vibrations within a uniform frequency range. Alternatively in other variations, different assemblies may be configured to vibrate within non-overlapping frequency ranges between each assembly. As mentioned above, each transducer 270, 272, 274, 276 can be programmed or preset for a different frequency response such that each transducer may be optimized for a different frequency response and/or transmission to deliver a relatively high-fidelity sound to the user.

[0097] Moreover, each of the different transducers 270, 272, 274, 276 can also be programmed to vibrate in a manner which indicates the directionality of sound received by the microphone worn by the user. For example, different transducers positioned at different locations within the user's mouth can vibrate in a specified manner by providing sound or vibrational queues to inform the user which direction a sound was detected relative to an orientation of the user. For instance, a first transducer located, e.g., on a user's left tooth, can be programmed to vibrate for sound detected originating from the user's left side. Similarly, a second transducer located, e.g., on a user's right tooth, can be programmed to vibrate for sound detected originating from the user's right side. Other variations and queues may be utilized as these examples are intended to be illustrative of potential variations.

[0098] In variations where the one or more microphones are positioned in intra-buccal locations, the microphone may be integrated directly into the electronics and/or transducer assembly, as described above. However, in additional variation, the microphone unit may be positioned at a distance from the transducer assemblies to minimize feedback. In one example, similar to a variation shown above, microphone unit 282 may be separated from electronics and/or transducer assembly 280, as shown in Figs. 27A and 27B. In such a

variation, the microphone unit 282 positioned upon or adjacent to the gingival surface 268 may be electrically connected via wire(s) 264.

[0099] Although the variation illustrates the microphone unit 282 placed adjacent to the gingival tissue 268, unit 282 may be positioned upon another tooth or another location within the mouth. For instance, Fig. 28 illustrates another variation 290 which utilizes an arch 19 connecting one or more tooth retaining portions 21, 23, as described above. However, in this variation, the microphone unit 294 may be integrated within or upon the arch 19 separated from the transducer assembly 292. One or more wires 296 routed through arch 19 may electrically connect the microphone unit 294 to the assembly 292. Alternatively, rather than utilizing a wire 296, microphone unit 294 and assembly 292 may be wirelessly coupled to one another, as described above.

[0100] In yet another variation for separating the microphone from the transducer assembly, Fig. 29 illustrates another variation where at least one microphone 302 (or optionally any number of additional microphones 304, 306) may be positioned within the mouth of the user while physically separated from the electronics and/or transducer assembly 300. In this manner, the one or optionally more microphones 302, 304, 306 may be wirelessly coupled to the electronics and/or transducer assembly 300 in a manner which attenuates or eliminates feedback, if present, from the transducer.

[0101] The applications of the devices and methods discussed above are not limited to the treatment of hearing loss but may include any number of further treatment applications. Moreover, such devices and methods may be applied to other treatment sites within the body. Modification of the above-described assemblies and methods for carrying out the invention, combinations between different variations as practicable, and variations of aspects of the invention that are obvious to those of skill in the art are intended to be within the scope of the claims.

CLAIMS

What is claimed is:

1. A two way communication device, comprising:
 - a. a mouth wearable communicator;
 - b. one or more body sensors; and
 - c. a linking unit coupled to the mouth wearable communicator and the one or more body sensors, the linking unit adapted to communicate with a remote station.
2. The two way communication device of claim 1, wherein the mouth wearable communicator comprises a bone conduction device.
3. The two way communication device of claim 1, wherein the mouth wearable communicator comprises a custom oral device.
4. The two way communication device of claim 1, wherein the mouth wearable communicator comprises one or more medical sensors embedded therein.
5. The two way communication device of claim 1, wherein the mouth wearable communicator comprises a data storage device.
6. The two way communication device of claim 5, wherein the data storage device is encrypted.
7. The two way communication device of claim 1, comprising a local transceiver coupling the mouth wearable communicator with the one or more body sensors and the linking unit.
8. The two way communication device of claim 7, wherein the local transceiver transmits encrypted data.
9. The two way communication device of claim 1, comprising a wireless local area network (LAN) or a wired LAN coupling the mouth wearable communicator with the one or more body sensors and the linking unit.
10. The two way communication device of claim 1, wherein the linking unit is coupled to a wide area network (WAN).
11. The two way communication device of claim 1, wherein the remote station comprises one of: a satellite, a cellular tower, a relay station mounted on an airplane or a helicopter, a relay station mounted on a blimp.

12. The two way communication device of claim 1, comprising a beacon coupled to the mouth wearable communicator to identify a person in need of assistance.
13. The two way communication device of claim 12, wherein the beacon comprises an audible signal, a location signal, a visible signal.
14. The two way communication device of claim 1, wherein the body sensor senses a vital sign or a measured parameter.
15. The two way communication device of claim 1, wherein the body sensor senses one or more of: body temperature, environment temperature, hydration, heart rate, EKG, EEG, pulse rate, oxygen saturation, respiratory cycle, air flow velocity, potential of hydrogen (pH) level.
16. The two way communication device of claim 1, comprising a microphone to pick up sound.
17. The two way communication device of claim 16, wherein the microphone comprises one of: an intraoral microphone, an extraoral microphone.
18. The two way communication device of claim 16, wherein the microphone cancels environmental noise and transmits a user's voice to the remote station.
19. The two way communication device of claim 1, wherein the mouth wearable communicator is used by one of: workers in loud environments, a professional entertainer or athlete and/or support personnel, a soldier, a medic, a fireman, an emergency worker.
20. The two way communication device of claim 16, comprising a wireless sensor network coupled to the mouth wearable communicator, the one or more body sensors, or the linking unit.
21. The two way communication device of claim 16, wherein the linking unit wirelessly communicates with other linking units to form a network for detection, identification and communication with a crew.
22. The two way communication device of claim 16, wherein the linking unit wirelessly communicates with other linking units to form a local area network.
23. The two way communication device of claim 1, comprising a housing having a shape which is conformable to at least a portion of at least one tooth;
an actuatable transducer disposed within or upon the housing and in vibratory communication with a surface of the at least one tooth; and

a wireless communication transceiver coupled to the transducer to provide received sound to the user and to provide communication for the user.

24. The two way communication device of claim 23, comprising an oral appliance having a shape which conforms to the at least one tooth.

25. The two way communication device of claim 23, comprising an electronic assembly disposed within or upon the housing and which is in communication with the transducer.

26. A method for providing two way communication, comprising:

- a. intraorally wearing a mouth wearable communicator;
- a. sensing one or more body parameters or environmental parameters; and
- b. linking to the mouth wearable communicator and the one or more body sensors to a remote station.

27. The method of claim 26, comprising transmitting sound using a bone conduction device.

28. The method of claim 26, comprising providing the mouth wearable communicator as a custom oral device.

29. The method of claim 26, comprising embedding one or more sensors in the mouth wearable communicator.

30. The method of claim 26, comprising storing medical or environmental data in the mouth wearable communicator.

31. The method of claim 26, comprising storing data in the mouth wearable communicator as a secured black box device for subsequent forensic analysis.

32. The method of claim 26, comprising monitoring user activity.

33. The method of claim 32, comprising using an accelerometer to detect whether the user is walking, moving, or running.

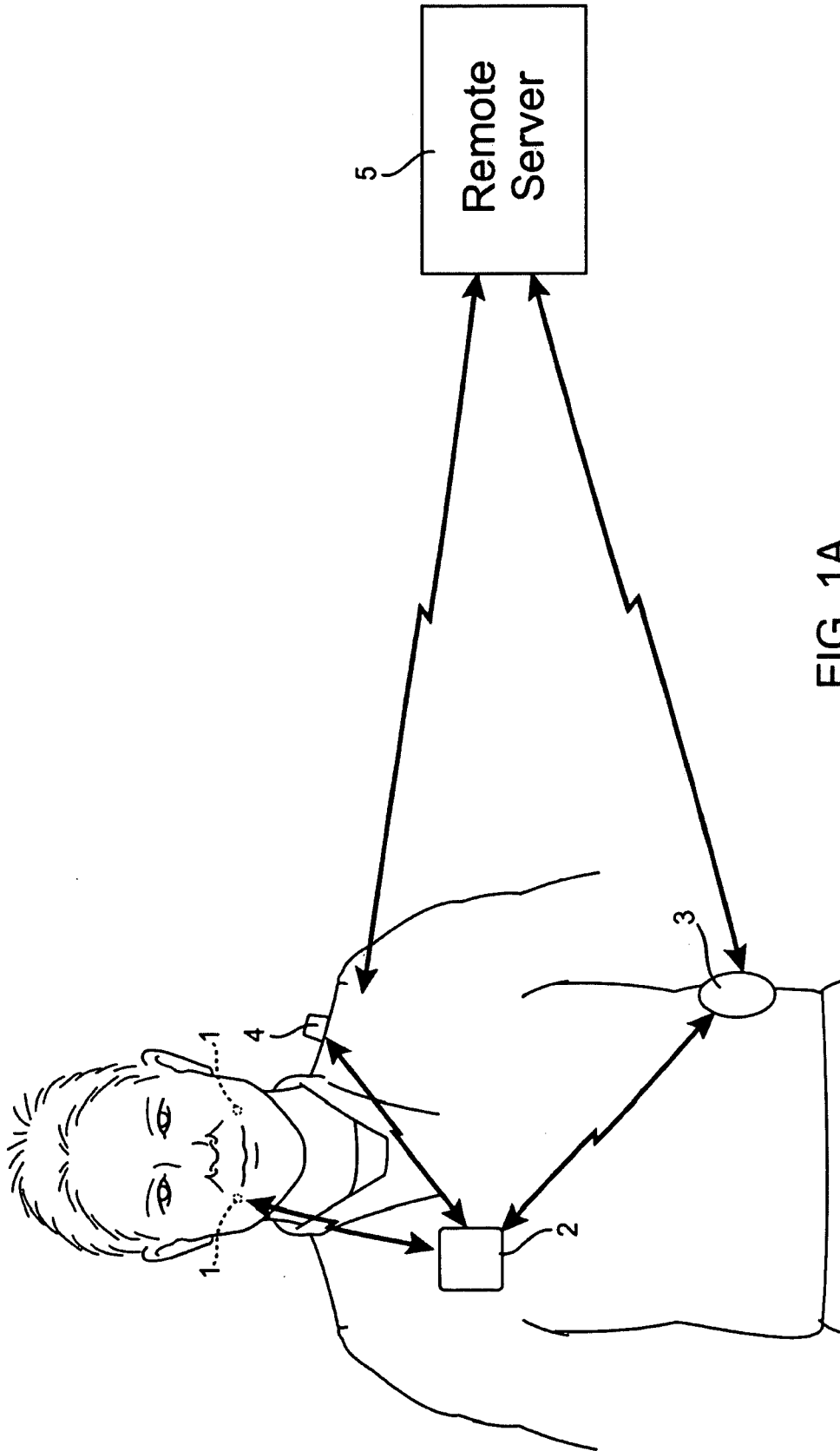

FIG. 1A

+

+

+

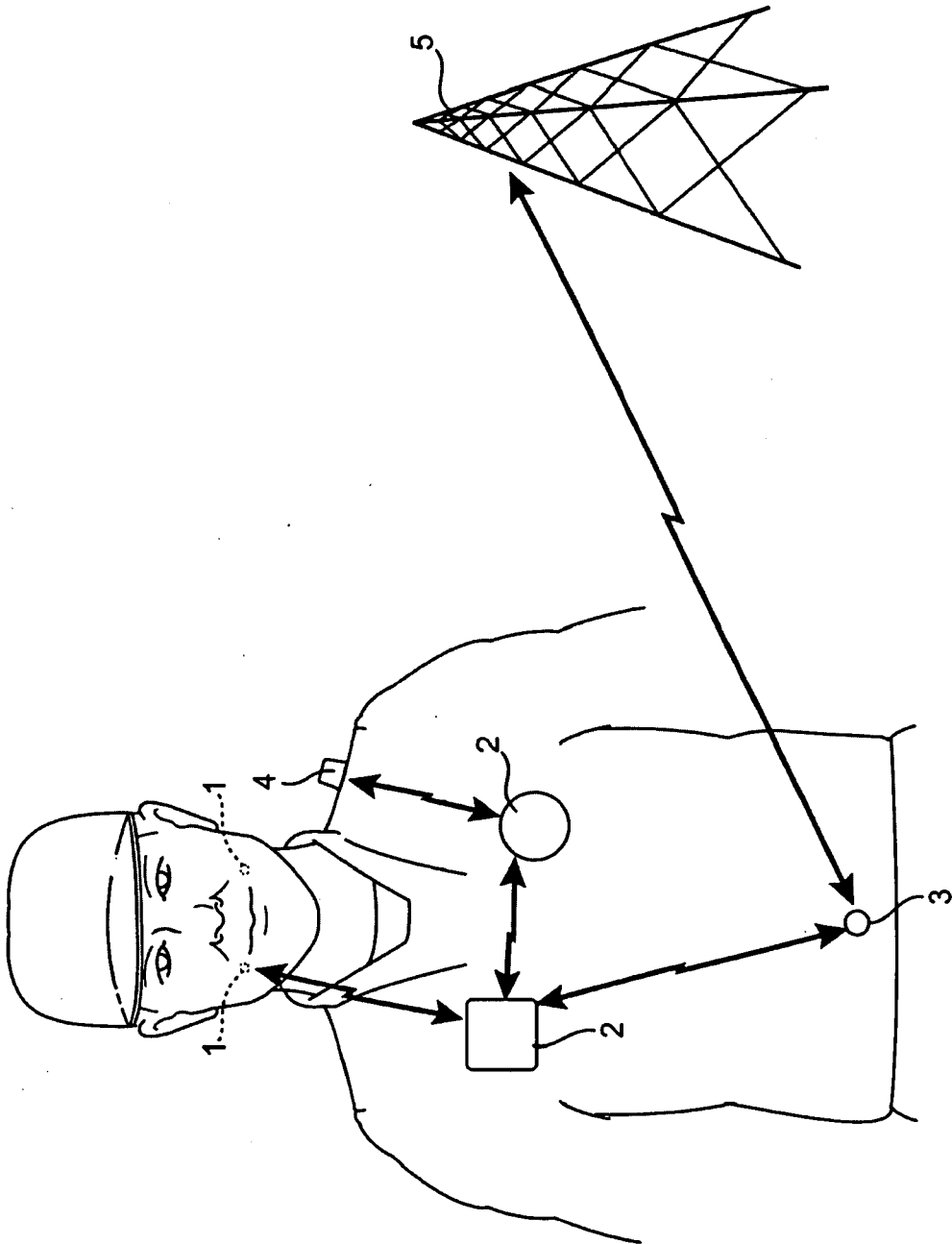

FIG. 1B

+

+

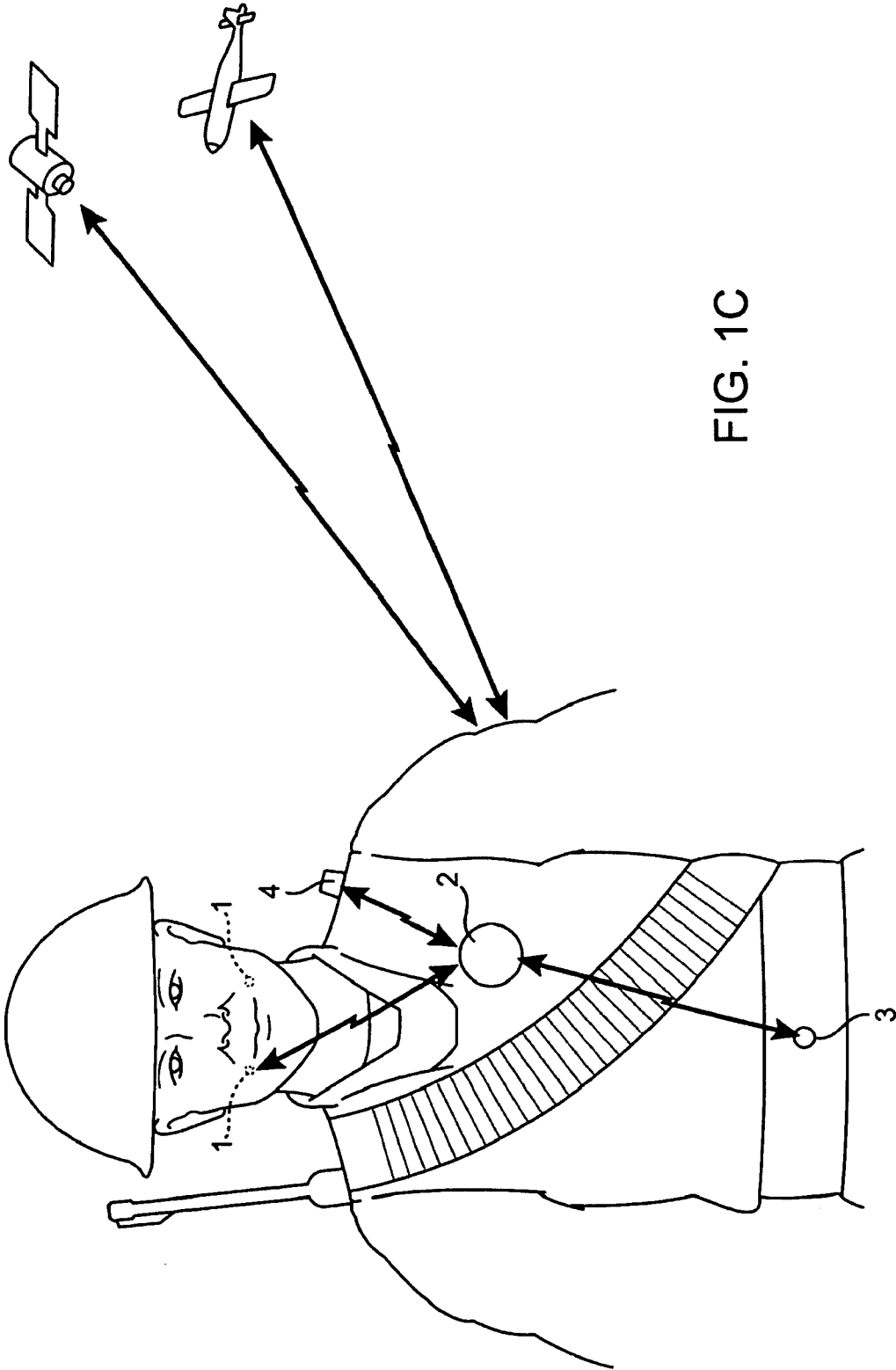

FIG. 1C

+

+

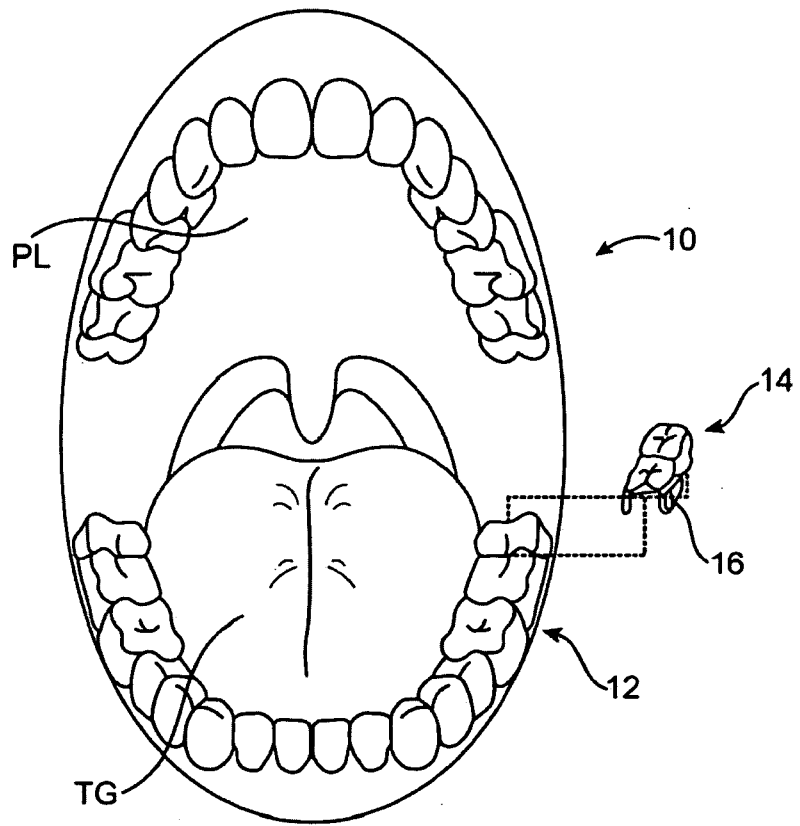

FIG. 1D

+

+

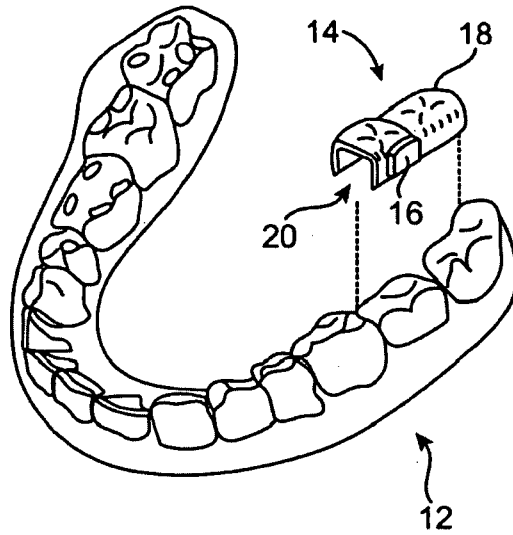

FIG. 2A

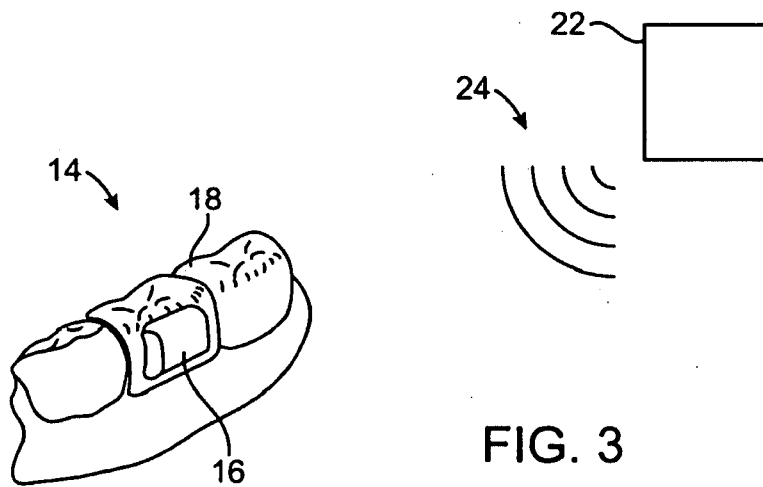

FIG. 3

+

+

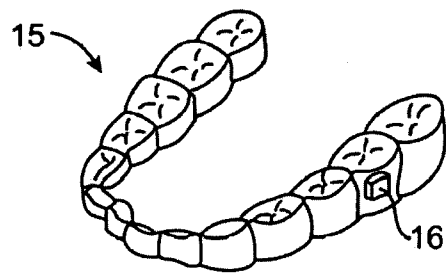

FIG. 2B

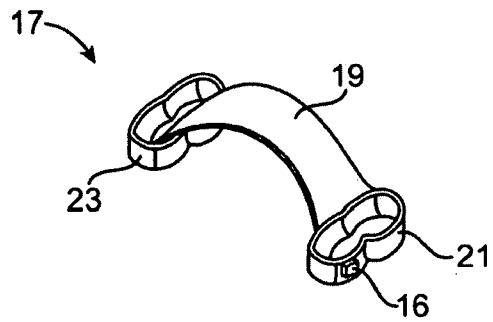

FIG. 2C

+

+

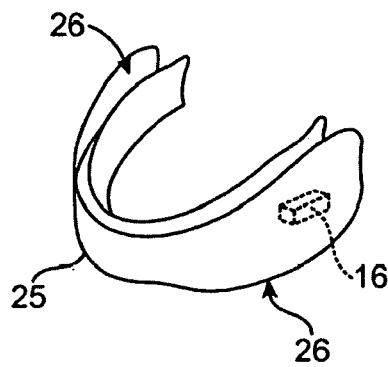

FIG. 2D

+

+

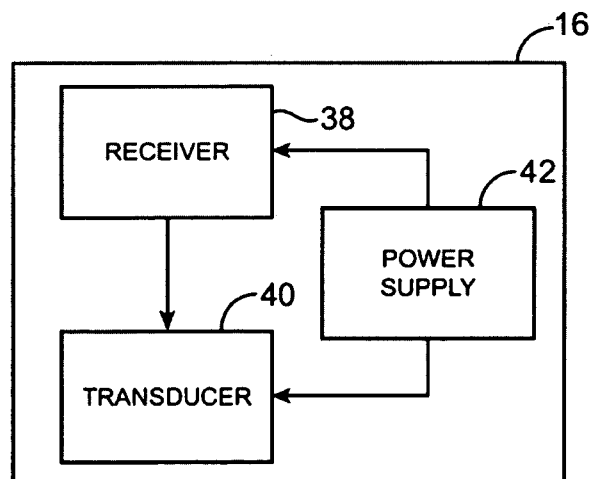
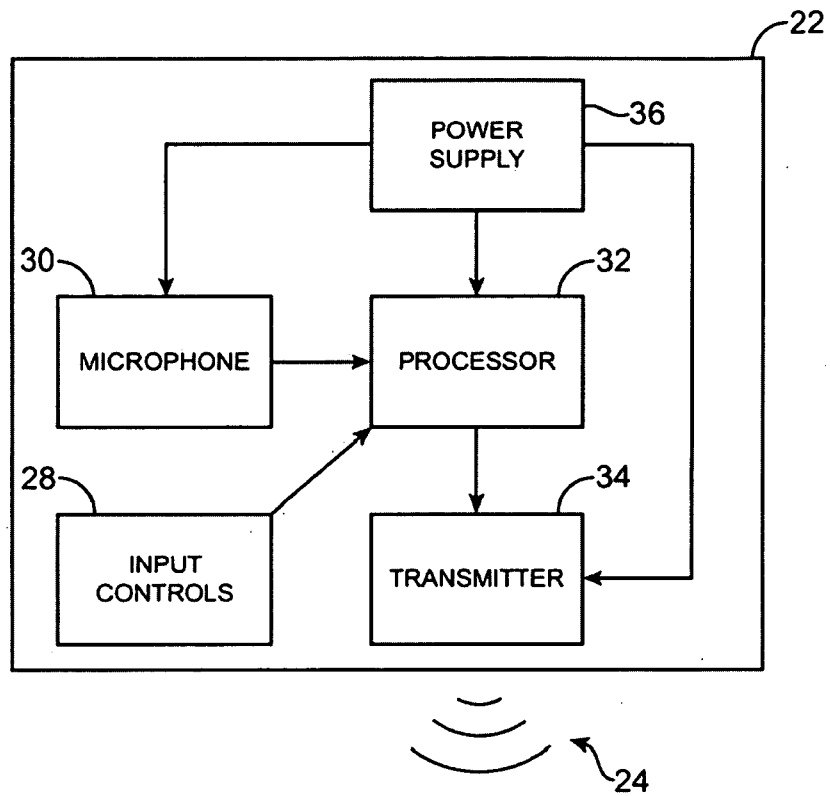

FIG. 4

+

+

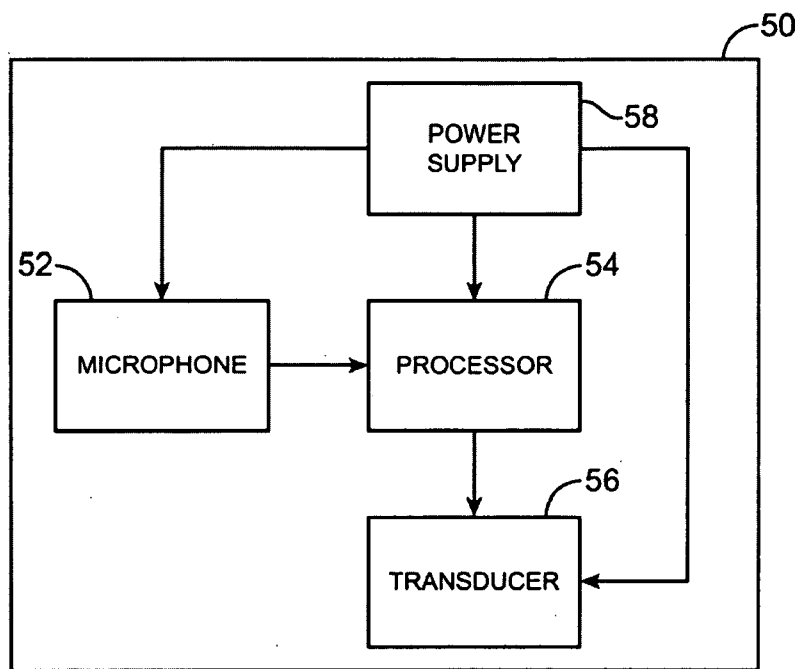

FIG. 5

+

+

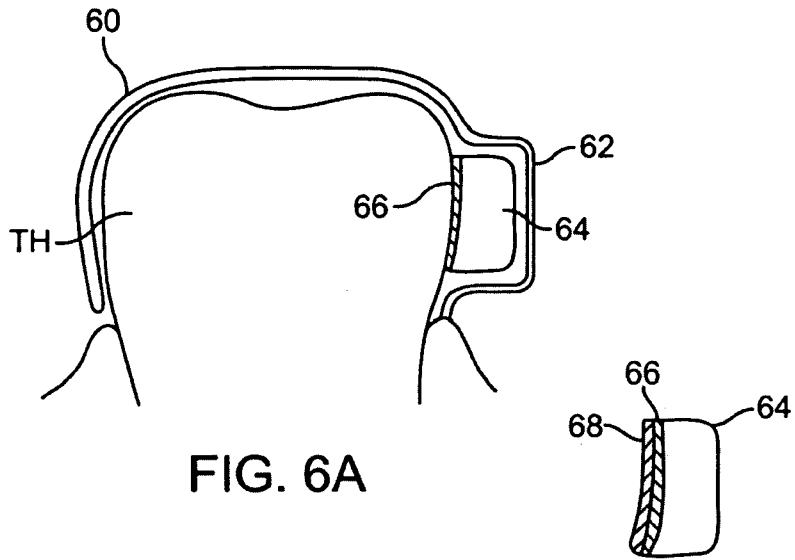

FIG. 6A

FIG. 6B

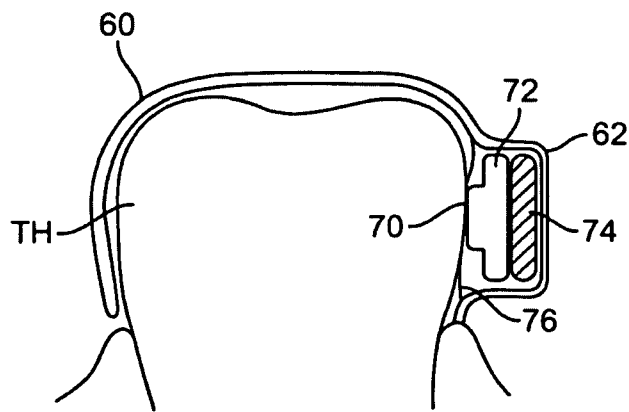

FIG. 7

+

+

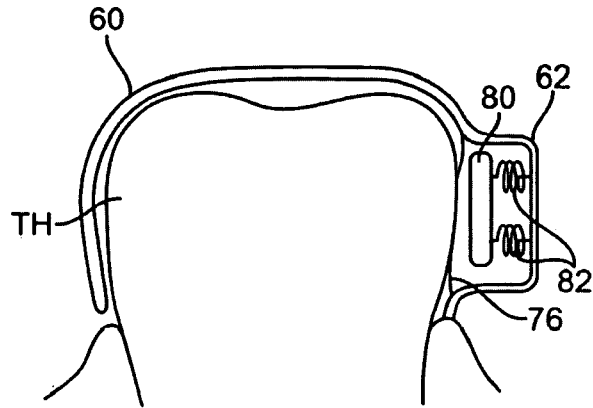

FIG. 8

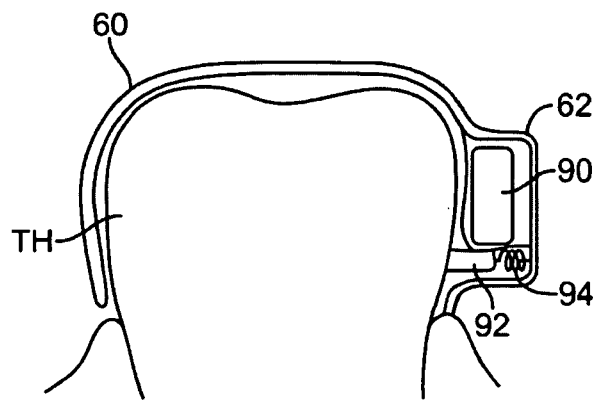

FIG. 9

+

+

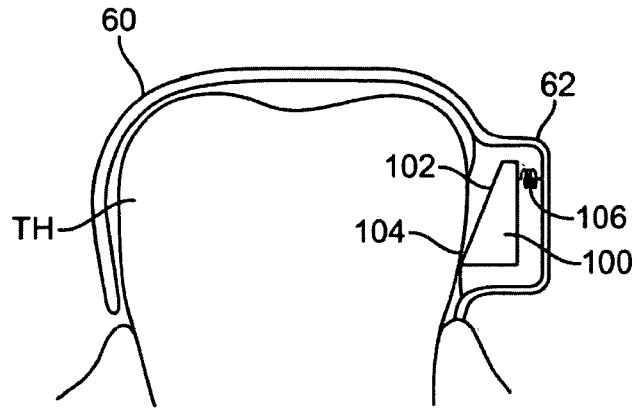

FIG. 10

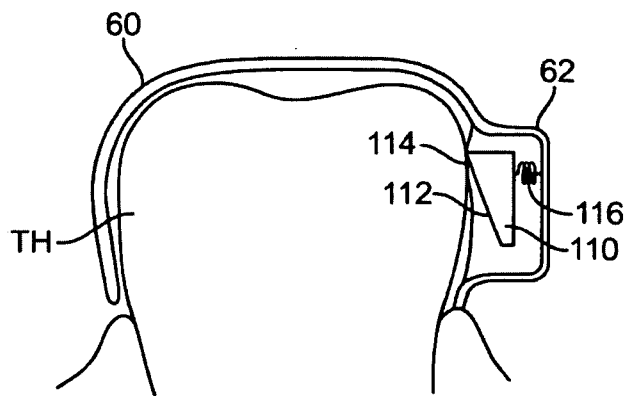

FIG. 11

+

+

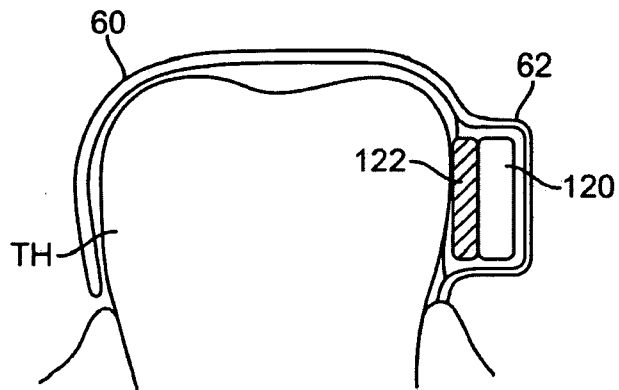

FIG. 12

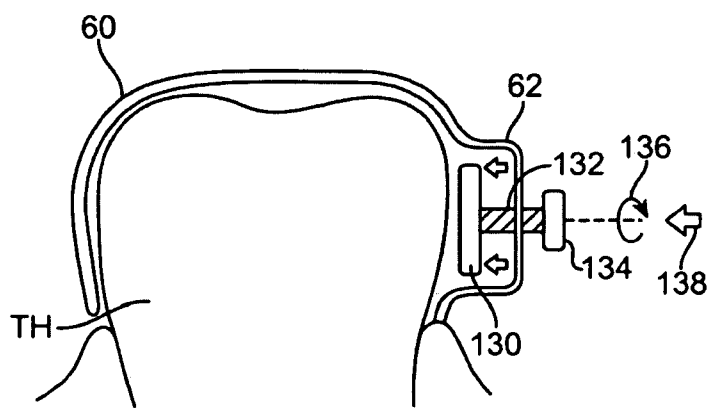

FIG. 13

+

+

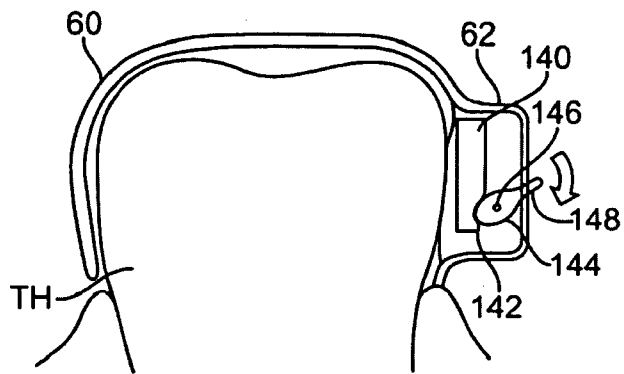

FIG. 14

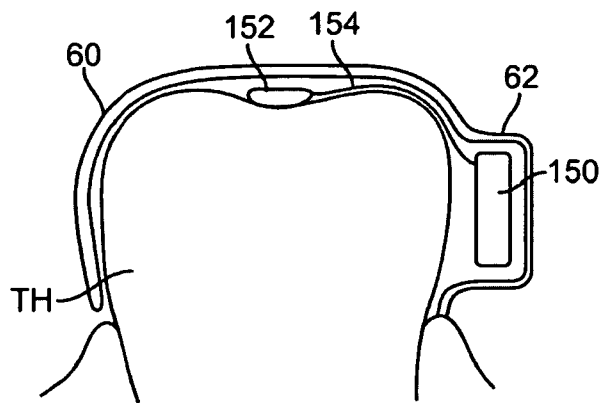

FIG. 15

+

+

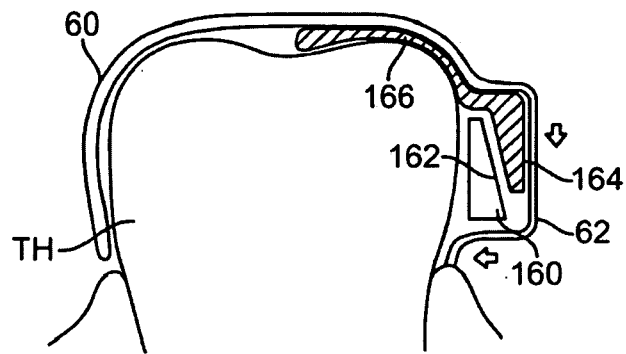

FIG. 16

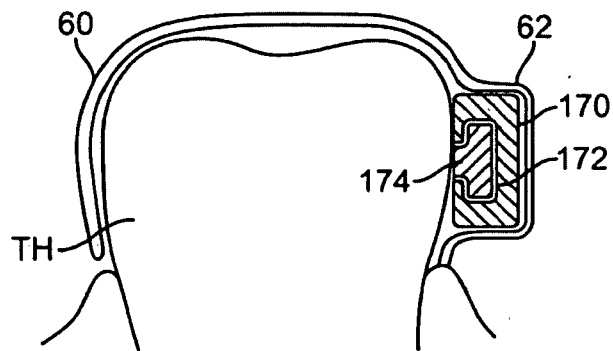

FIG. 17

+

+

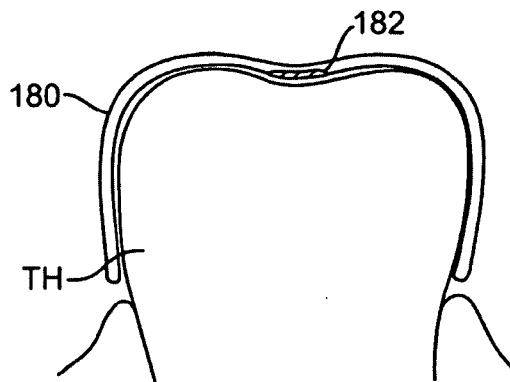

FIG. 18A

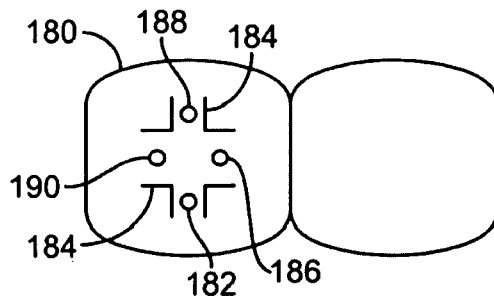

FIG. 18B

+

+

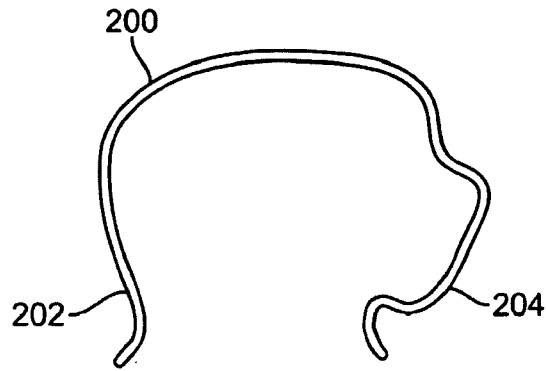

FIG. 19A

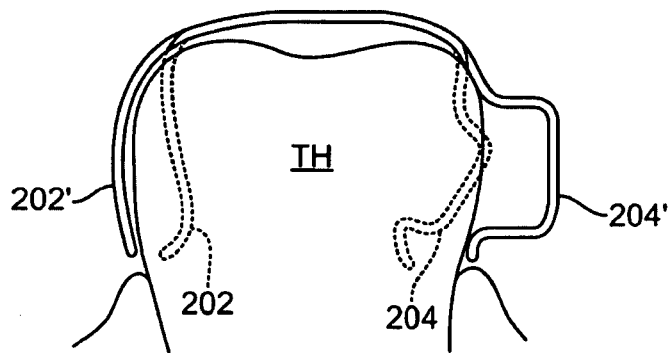

FIG. 19B

+

+

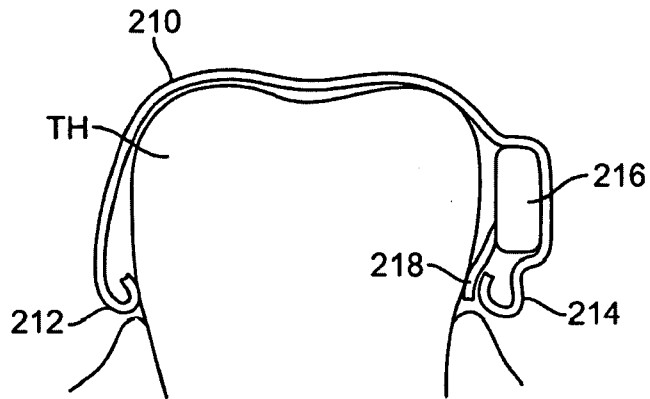

FIG. 20

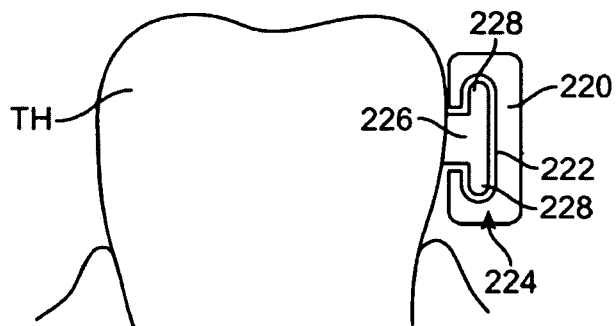

FIG. 21

+

+

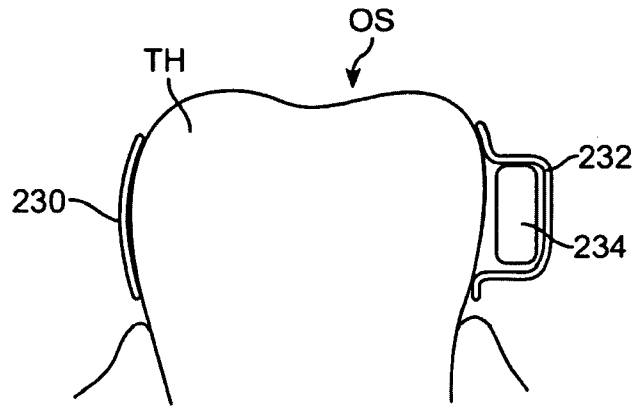

FIG. 22A

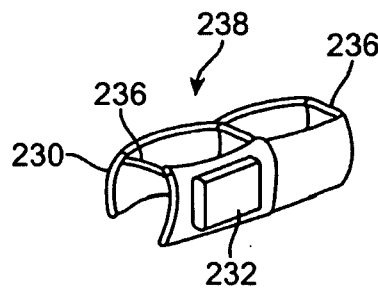

FIG. 22B

+

+

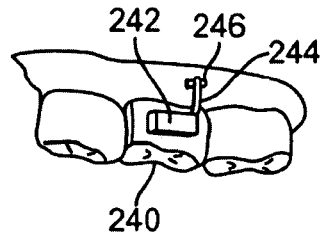

FIG. 23A

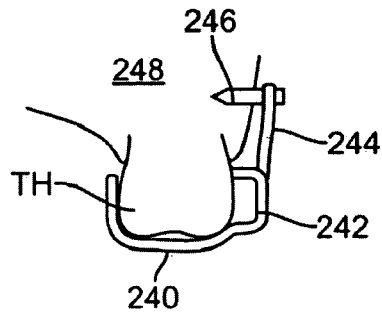

FIG. 23B

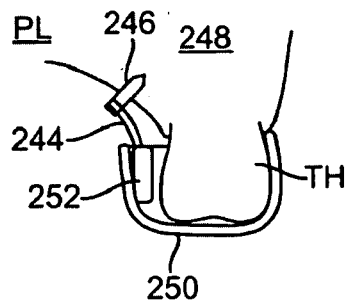

FIG. 24

+

+

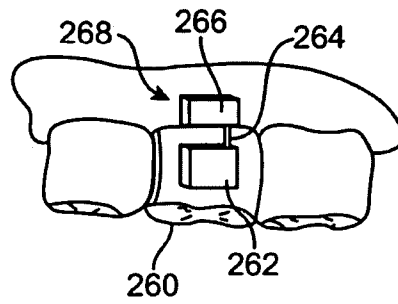

FIG. 25A

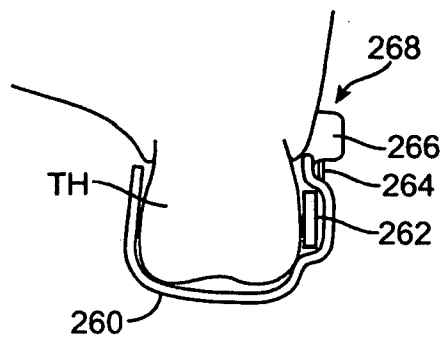

FIG. 25B

+

+

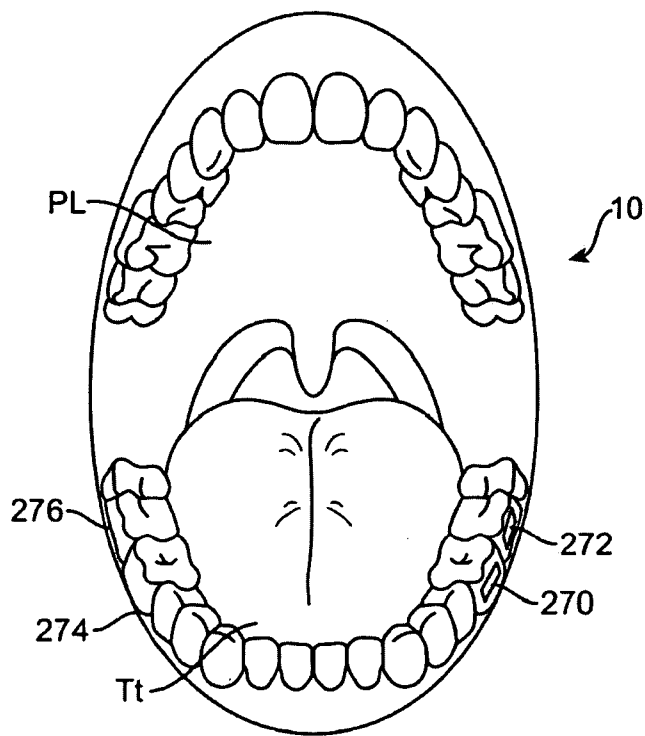

FIG. 26

+

+

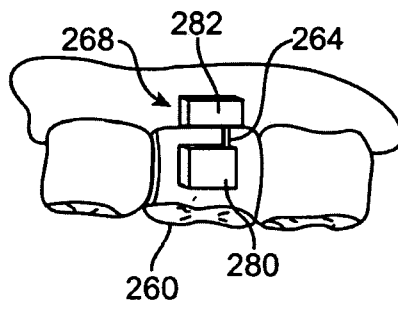

FIG. 27A

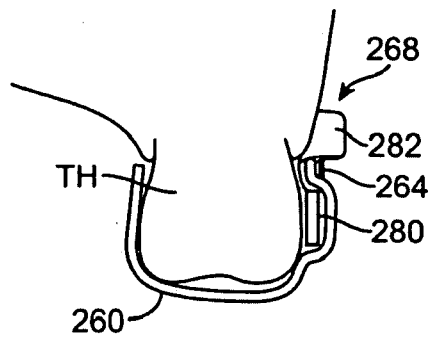

FIG. 27B

+

+

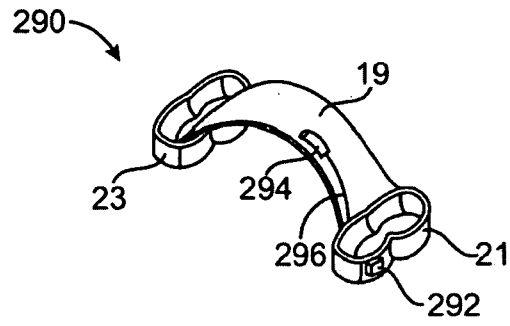

FIG. 28

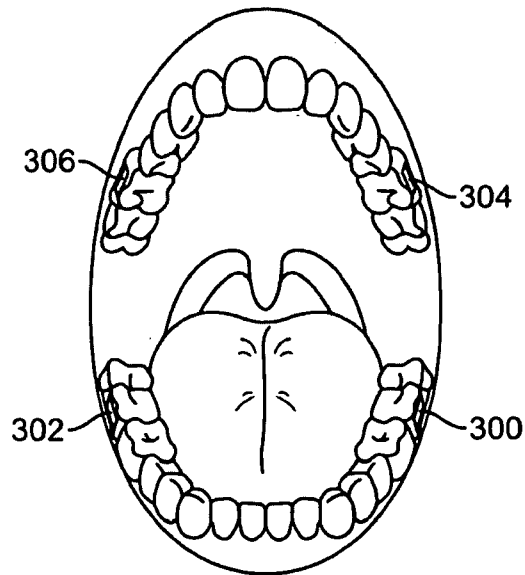

FIG. 29

+

INTERNATIONAL SEARCH REPORT

International application No.

PCT/US 08/85706

A. CLASSIFICATION OF SUBJECT MATTER IPC(8) - H04R 1/00 (2009.01) USPC - 381/344 According to International Patent Classification (IPC) or to both national classification and IPC		
B. FIELDS SEARCHED Minimum documentation searched (classification system followed by classification symbols) IPC(8): H04R 1/00 (2009.01) USPC: 381/344 Documentation searched other than minimum documentation to the extent that such documents are included in the fields searched USPC: 381/61, 63, 150, 191, 337, 344, 385; 455/73, 550.1 (view text search terms below) Electronic data base consulted during the international search (name of data base and, where practicable, search terms used) pubWEST(PGPB,USPT,EPAB,JPAB; PLUR=YES); Google Scholar Text search terms: two-way, 2-way, point, to, point, communication, wireless, channel, frequency, mouth, oral, wearable, worn, wear, bone, tooth, sensor, encrypt, wire, wireless, LAN, WAN, transceiver, transmitter, receiver, satellite...		
C. DOCUMENTS CONSIDERED TO BE RELEVANT		
Category*	Citation of document, with indication, where appropriate, of the relevant passages	Relevant to claim No.
X	US 2007/0276270 A1 (TRAN) 29 November 2007 (29.11.2007) entire document, especially Abstract, Figs.1 and 6B; and para [0013], [0017]-[0018], [0032], [0055], [0062], [0064], [0183]-[0184], [0213], [0215], [0218], [0222], [0226], [0237], [0244], [0246]-[0247], [0250], [0258], [0273], [0275], [0279], [0282], [0292], [0336] and [0416]	1-10, 12-22, 26-33
Y		11, 23-25
Y	US 2006/0064037 A1 (SHALON, et al.) 23 March 2006 (23.03.2006) entire document, especially Abstract, Figs.1A-1B and 1D; and para [0009], [0130], [0165], [0168], [0237], [0331] and [0403]	11, 23-25
A	US 2007/0265533 A1 (TRAN) 15 November 2007 (15.11.2007) entire document	1-33
A	ALTMANN et al. "Foresighting the New Technology Wave - Expert Group." In: State of the Art Reviews and Related Papers - Center on Nanotechnology and Society, 2004 Conference [online]. Published June 14, 2004, page 1-291 [retrieved on 2009-01-11]. Retrieved from the Internet: <URL: http://www.nano-and-society.org/NELSI/documents/ECreviewsandpapers061404.pdf > entire document	1-33
<input type="checkbox"/> Further documents are listed in the continuation of Box C. <input type="checkbox"/>		
* Special categories of cited documents: "A" document defining the general state of the art which is not considered to be of particular relevance "E" earlier application or patent but published on or after the international filing date "L" document which may throw doubts on priority claim(s) or which is cited to establish the publication date of another citation or other special reason (as specified) "O" document referring to an oral disclosure, use, exhibition or other means "P" document published prior to the international filing date but later than the priority date claimed "T" later document published after the international filing date or priority date and not in conflict with the application but cited to understand the principle or theory underlying the invention "X" document of particular relevance; the claimed invention cannot be considered novel or cannot be considered to involve an inventive step when the document is taken alone "Y" document of particular relevance; the claimed invention cannot be considered to involve an inventive step when the document is combined with one or more other such documents, such combination being obvious to a person skilled in the art "&" document member of the same patent family		
Date of the actual completion of the international search 11 January 2009 (11.01.2009)		Date of mailing of the international search report 06 FEB 2009
Name and mailing address of the ISA/US Mail Stop PCT, Attn: ISA/US, Commissioner for Patents P.O. Box 1450, Alexandria, Virginia 22313-1450 Facsimile No. 571-273-3201		Authorized officer: Lee W. Young PCT Helpdesk: 571-272-4300 PCT OSP: 571-272-7774

专利名称(译)	提供往口可穿戴通信器的双向通信的系统和方法		
公开(公告)号	EP2227912A1	公开(公告)日	2010-09-15
申请号	EP2008857987	申请日	2008-12-05
[标]申请(专利权)人(译)	索尼图斯医疗公司		
申请(专利权)人(译)	SONITUS MEDICAL , INC.		
当前申请(专利权)人(译)	SONITUS MEDICAL , INC.		
[标]发明人	ABOLFATHI AMIR KASSAYAN REZA		
发明人	ABOLFATHI, AMIR KASSAYAN, REZA		
IPC分类号	H04R1/00 A61B5/00 A61B5/11 H04W4/90		
CPC分类号	A61B5/0002 A61B5/1112 A61B5/4504 A61B5/682 A61B5/7465 G16H10/65 G16H80/00 H04L67/12 H04L67/18 H04M1/05 H04M1/6066 H04B1/38 H04B1/385 H04M1/60 H04M1/6033 H04M1/725 H04M1/72527 G06F19/3418		
优先权	12/952780 2007-12-07 US		
其他公开文献	EP2227912A4		
外部链接	Espacenet		

摘要(译)

电子和换能器装置可以附接，粘附或以其他方式嵌入可移除的口腔器具或其他口腔装置中或上，以形成双向通信组件。在另一个实施例中，该装置提供电子和换能器装置，其可以附接，粘附或以其他方式嵌入可移除的口腔器具或其他口腔装置中或上，以形成包含患者可识别信息的医疗标签。这种口腔器具可以是利用通过传统牙科印模方法获得的牙科结构的复制模型的热成形工艺制造的定制装置。电子和换能器组件可以直接或通过接收器接收输入声音，以处理和放大信号，并通过耦合到牙齿或其他骨结构（例如上颌骨，下颌骨或腭骨）的振动换能器元件传输处理过的声音。结构体。