



(11) **EP 2 201 891 A1**

(12) **EUROPEAN PATENT APPLICATION**
published in accordance with Art. 153(4) EPC

(43) Date of publication:
30.06.2010 Bulletin 2010/26

(51) Int Cl.:
A61B 5/145 (2006.01)

(21) Application number: **08715148.6**

(86) International application number:
PCT/CN2008/070412

(22) Date of filing: **21.03.2008**

(87) International publication number:
WO 2009/114963 (24.09.2009 Gazette 2009/39)

(84) Designated Contracting States:
**AT BE BG CH CY CZ DE DK EE ES FI FR GB GR
HR HU IE IS IT LI LT LU LV MC MT NL NO PL PT
RO SE SI SK TR**
Designated Extension States:
AL BA MK RS

(72) Inventor: **WANG, Weihu**
Beijing 100039 (CN)

(71) Applicant: **Beijing Choice Electronic Technology
Co., Ltd.**
Beijing 100039 (CN)

(74) Representative: **Vogelbruch, Fabian et al**
Cohausz & Florack
Patent- und Rechtsanwälte
Partnerschaftsgesellschaft
Bleichstraße 14
D-40211 Düsseldorf (DE)

(54) **SOFT FINGER COT BLOOD OXYGEN MEASURING DEVICE**

(57) The present invention discloses a soft gum fingerstall oximeter without pivot structure, the soft gum fingerstall oximeter (21) comprises a soft gum fingerstall (11) which can wraps around a finger closely with variations of the profile of the finger and causes a clamping

force distributed on the clamped portion of the finger uniformly. An emission circuit board and a reception circuit board are provided in the soft gum fingerstall (11). The soft gum fingerstall (11) of the oximeter (21) is enclosed, which can shield light entering from a side.

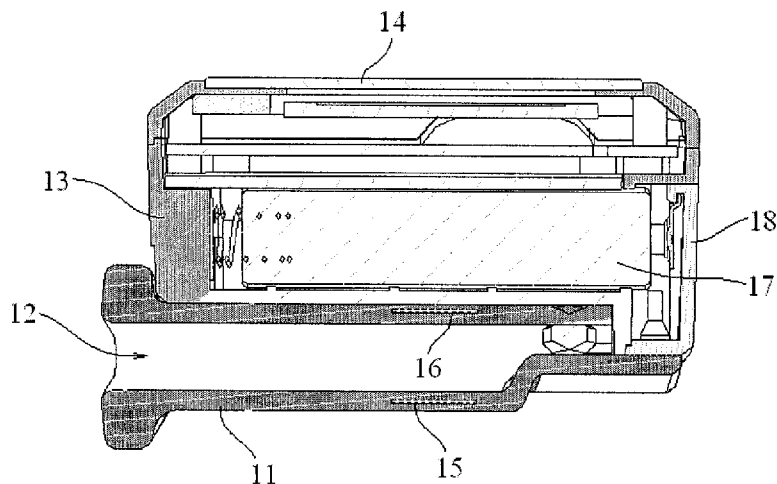

Fig.1B

EP 2 201 891 A1

Description

Field of the Invention

[0001] The present invention relates to a finger clip oximeter, and particularly relates to a soft gum fingerstall oximeter without pivot structure.

Background of the Invention

[0002] Generally, a finger clip oximeter according to the prior art includes an upper case and a lower case which are connected with each other by a pivot, can be rotated around the pivot relatively and be separated by a certain distance from each other. The upper and lower cases apply a clamping pressure to a nail of a measured finger by a coil spring.

[0003] However, when the finger clip oximeter clamps the nail to perform oximetric measurement, the upper and lower cases are opened a certain angle with respect to each other necessarily. After the upper and lower cases are opened, light will enter from a side thereby to influence the measurement result in case that the light is strong. Different persons have different sizes of fingers, therefore, the angles which the upper and lower cases are opened with respect to each other are different and the influences owing to light entering from a side are different as well. Accordingly, the finger clip oximeter is hard to perform calibration on fingers with various sizes in advance, so that a light path offset occurs easily during its practical use resulting in a measuring error.

[0004] In addition, in the finger clip oximeter according to the prior art, a finger clamping portion of the upper and lower cases applies a non uniform force to a finger along the length of the finger, and the smaller clamping force exists in the location which is more away from the hinged pivot. Because different users are different largely in sizes of fingers, the clamping portion of the finger clip oximeter according to the prior art can only be defined within a prescribed range of size, and it is impossible that any specific finger clip oximeter according to the prior art is applicable to a finger which is too thick or too thin. Therefore, the range in which the finger clip oximeter according to the prior art can be applied is limited. Further, for a user with thicker fingers, the user's fingers are not comfortable when he uses the finger clip oximeter according to the prior art.

[0005] Since the finger clip oximeter according to the prior art is limited in its structure, a portion where the cases contact with a finger can not be cleaned conveniently and thoroughly. Therefore, there is a risk of cross propagation of bacteria among different users in use.

[0006] Also, the finger clip oximeter according to the prior art is complicated in structure and difficult to be assembled.

Summary of the Invention

[0007] An object of the present invention is to provide a soft gum fingerstall oximeter without pivot structure which can shield light entering from a side and can be used normally to obtain an accurate measurement result in a strong light environment.

[0008] Another object of the present invention is to provide a soft gum fingerstall oximeter without pivot structure which can reduce a light path offset and improve accuracy of measurement.

[0009] Still another object of the present invention is to provide a soft gum fingerstall oximeter without pivot structure, in which the soft gum fingerstall wraps around a finger closely with variations of the profile of the finger and a clamping force is distributed on the clamped portion of the finger uniformly by use of the physical flexibility of silicon rubber, so that a human-machine contact surface is changed and comfort is improved.

[0010] Yet still another object of the present invention is to provide a soft gum fingerstall oximeter without pivot structure, in which a portion where the cases contact with a finger can be cleaned conveniently and thoroughly, thus, there is no risk of cross propagation of bacteria among the users in use.

[0011] Again yet still another object of the present invention is to provide a soft gum fingerstall oximeter without pivot structure, in which the structure of the product is simplified and the reliability of the product is improved.

[0012] For this reason, the invention provides a soft gum fingerstall oximeter without pivot structure, **characterized in that** the soft gum fingerstall oximeter comprises a soft gum fingerstall which wraps around a finger with variations of the profile of the finger and causes a clamping force distributed on the clamped portion of the finger uniformly, and an emission circuit board and a reception circuit board are provided in the soft gum fingerstall.

[0013] Preferably, the soft gum fingerstall oximeter further comprises a housing in which electronic elements including a data processing circuit board, a test report display screen, operation keys, a battery, a speaker and a mini USB data output port are provided, and the housing is provided on a side outside of the soft gum fingerstall and is connected to the soft gum fingerstall detachably.

[0014] Preferably, all of the electronic elements including a data processing circuit board, a measuring circuit board, a test report display screen, operation keys, a battery, a speaker, and a mini USB data output port are fixed within a soft silica gel sheath, a stainless steel connecting plate which is used to fix and protect the electronic elements is imbedded in the soft silica gel sheath, the stainless steel connecting plate is hot pressed to and inserted into the soft silica gel sheath to form a single unit, and the outline of the connecting plate varies along profiles of a top surface and side surfaces of the soft silica gel sheath.

[0015] Preferably, electronic elements including a data processing circuit board, a test report display screen, op-

eration keys, a battery, a speaker and a mini USB data output port are provided in a housing in which horizontal dragging slideways for soft gum slide plates are provided, an upper soft gum fingerstall and a lower soft gum fingerstall are fixed to the soft gum slide plates respectively, while the soft gum slide plates are mounted on the horizontal dragging slideways for the soft gum slide plates in the housing respectively, measuring elements are attached to the soft gum fingerstalls, and the measuring elements attached to the soft gum fingerstalls are connected to an interface circuit board in the housing via a pin socket.

[0016] The soft gum fingerstall oximeter according to the present invention has an enclosed silica gel fingerstall which can shield light entering from a side so that the oximeter can be used normally to obtain an accurate measurement result in a strong light environment.

[0017] The soft gum fingerstall oximeter according to the present invention has an enclosed silica gel fingerstall which can reduce a light path offset and improve accuracy of measurement.

[0018] The soft gum fingerstall oximeter according to the present invention has an enclosed silica gel fingerstall in which the soft gum fingerstall wraps around a finger closely with variations of the profile of the finger by use of the physical flexibility of silicon rubber and causes a clamping force distributed on the clamped portion of the finger uniformly so that a human-machine contact surface is changed and comfort is improved.

[0019] The soft gum fingerstall oximeter according to the present invention has an enclosed silica gel fingerstall in which a portion where the cases contact with a finger can be cleaned conveniently and thoroughly by use of the physical flexibility of silicon rubber, thus, there is no risk of cross propagation of bacteria among the users in use.

[0020] The soft gum fingerstall oximeter according to the present invention has an enclosed silica gel fingerstall in which the structure of the product is simplified and the reliability of the product is improved by eliminating the pivot and the coil spring in the prior art.

Brief Description of the Drawings

[0021]

Fig. 1A is a perspective diagram of a soft gum fingerstall oximeter according to a first embodiment of the present invention;

Fig. 1B is a longitudinal section view along a line I-I in Fig. 1A;

Fig. 1C is a transverse section view along a line II-II in Fig. 1A;

Fig. 2A is a perspective diagram of a soft gum fingerstall oximeter according to a second embodiment of the present invention;

Fig. 2B is a longitudinal section view along a line L-L in Fig. 2A;

Fig. 2C is a transverse section view along a line W-W in Fig. 2A;

Fig. 3A is a perspective diagram of a soft gum fingerstall oximeter according to a third embodiment of the present invention;

Fig. 3B is a longitudinal section view along a line A-A in Fig. 3A;

Fig. 3C is a transverse section view along a line B-B in Fig. 3A.

Detailed Description of the Preferred Embodiments

[0022] According to a first embodiment of the present invention, as shown in Figs. 1A, 1B and 1C, a soft gum fingerstall oximeter is a box like oximeter which includes a housing 13 and a silica gel fingerstall 11. The housing 13 is provided outside the silica gel fingerstall 11 which is a soft fingerstall and on which a number of umbrella shaped connectors (not shown) are provided. These umbrella shaped connectors can be snapped into the housing 13 to connect the silica gel fingerstall 11 with the housing 13.

[0023] If the silica gel fingerstall 11 is required to be replaced, all we need is to hold the housing 13 and pull the silica gel fingerstall 11 with a little force, that is, the silica gel fingerstall 11 can be separated from the housing 13 conveniently.

[0024] In this embodiment, measuring elements 15, 16 are provided on the silica gel fingerstall 11. A data processing circuit board, a test report display screen 14, operation keys, a battery 17, a speaker, a mini USB data output port and the like are provided in the housing 13. The measuring elements 15, 16 fixed to the silica gel fingerstall 11 are connected to an interface circuit board in the housing 13 via a pin socket. A reference numeral 18 denotes a battery cap.

[0025] When a finger is inserted into the silica gel fingerstall 11 from an opening 12 of the silica gel fingerstall 11, the silica gel fingerstall 11 wraps around the finger closely with variations of the profile of the finger and causes a clamping force distributed on the clamped portion of the finger uniformly.

[0026] The silica gel fingerstall 11 has a wider elastic range, which is adaptable to a larger variation of the sizes of fingers.

[0027] The silica gel fingerstall 11 is in a totally enclosed form, which prevents the side strong light from disturbing the measurement.

[0028] Since a pivot structure is eliminated, the reliability of the oximeter is improved.

[0029] According to a second embodiment of the present invention, as shown in Figs. 2A, 2B and 2C, a soft gum fingerstall oximeter 21 is an integral soft silica gel sheath oximeter in which all of electronic elements are placed in a soft silica gel sheath 22.

[0030] In order that all of the electronic elements are fixed within the soft silica gel sheath 22, a stainless steel connecting plate, which is hot pressed to and inserted into the soft silica gel sheath 22 to form a single unit, is

imbedded in the soft silica gel sheath 22. The outline of the connecting plate varies along profiles of a top surface and side surfaces of the soft silica gel sheath 22 to function as fixing and protecting the elements.

[0031] A data processing circuit board 27, measuring circuit boards 25, 26, a test report display screen 23, operation keys, a battery 28, a speaker, a mini USB data output port and the like are provided in the soft silica gel sheath 22.

[0032] When a finger is inserted into the soft silica gel sheath 22 from an opening 24, soft silica gel sheath 22 wraps around the finger closely with variations of the profile of the finger and causes a clamping force distributed on the clamped portion of the finger uniformly.

[0033] The soft silica gel sheath 22 has a wider elastic range, which is adaptable to a larger variation of the sizes of fingers.

[0034] In this embodiment, because all of the electronic elements are contained in the soft silica gel sheath 22, the material of the sheath can absorb impact force from the exterior, thus the soft silica gel sheath further has a drop-proof function.

[0035] The soft silica gel sheath 22 is in a totally enclosed form, which prevents the side strong light from disturbing the measurement.

[0036] Since a pivot structure is eliminated, the reliability of the oximeter is improved.

[0037] According to a third embodiment of the present invention, as shown in Figs. 3A, 3B and 3C, a soft gum fingerstall oximeter is a box like soft gum finger plate oximeter. A housing 31 in which horizontal dragging slideways for soft gum slide plates 35, 37 are provided is provided in the soft gum fingerstall oximeter. An upper soft gum fingerstall 36 and a lower soft gum fingerstall 34 are fixed to the soft gum slide plates 37, 35 respectively, while the soft gum slide plates 37, 35 are mounted on the horizontal dragging slideways for the soft gum slide plates in the housing 31 respectively. Measuring elements 39, 38 are attached to the soft gum fingerstalls 36, 34 respectively.

[0038] After the soft gum slide plates 37, 35 are dragged out of the housing 31, the upper and lower soft gum fingerstalls 36, 34 can be replaced conveniently. The measuring elements 39, 38 fixed to the soft gum fingerstalls 36, 34 respectively are connected to an interface circuit board in the housing 31 via a pin socket.

[0039] A data processing circuit board, a test report display screen 33, operation keys, a battery 40, a speaker, a mini USB data output port and the like are provided in the housing 31.

[0040] When a finger is inserted into the soft gum fingerstalls 36, 34 from an opening 32, the soft gum fingerstalls 36, 34 wrap around the finger closely with variations of the profile of the finger and cause a clamping force distributed on the clamped portion of the finger uniformly.

[0041] The soft gum fingerstalls 36, 34 have a wider elastic range, which is adaptable to a larger variation of the sizes of fingers.

[0042] The soft gum fingerstalls 36, 34 are completely provided in the housing 31 which is in a totally enclosed form, which prevents the side strong light from disturbing the measurement.

[0043] Since a pivot structure is eliminated, the reliability of the oximeter is improved.

[0044] Though the three embodiments of the present invention have been described above, those skilled in the art can understand that various modifications, improvements and substitutions can be made to the present invention, but all of these modifications, improvements and substitutions fall within the scope of the invention defined by the appended claims.

Claims

1. A soft gum fingerstall oximeter without pivot structure, **characterized in that** the soft gum fingerstall oximeter comprises a soft gum fingerstall which wraps around a finger closely with variations of the profile of the finger and causes a clamping force distributed on the clamped portion of the finger uniformly, and an emission circuit board and a reception circuit board are provided in the soft gum fingerstall.
2. The soft gum fingerstall oximeter without pivot structure according to claim 1, further comprising a housing in which electronic elements including a data processing circuit board, a test report display screen, operation keys, a battery, a speaker and a mini USB data output port are provided, and the housing is placed in a side outside of the soft gum fingerstall and is connected to the soft gum fingerstall detachably.
3. The soft gum fingerstall oximeter without pivot structure according to claim 1, wherein, all of the electronic elements including a data processing circuit board, a test report display screen, operation keys, a battery, a speaker, and a mini USB data output port are fixed within a soft silica gel sheath, a stainless steel connecting plate which is used to fix and protect the electronic elements is imbedded in the soft silica gel sheath, the stainless steel connecting plate is hot pressed to and inserted into the soft silica gel sheath to form a single unit, and the outline of the stainless steel connecting plate varies along profiles of a top surface and side surfaces of the soft silica gel sheath.
4. The soft gum fingerstall oximeter without pivot structure according to claim 1, wherein, electronic elements including a data processing circuit board, a test report display screen, operation keys, a battery, a speaker and a mini USB data output port are provided in a housing in which horizontal dragging slideways for soft gum slide plates are provided, an upper

soft gum fingerstall and a lower soft gum fingerstall are fixed to the soft gum slide plates respectively, while the soft gum slide plates are mounted on the horizontal dragging slideways for the soft gum slide plates in the housing respectively, measuring elements are attached to the soft gum fingerstalls, and the measuring elements attached to the soft gum fingerstalls are connected to an interface circuit board in the housing via a pin socket.

5

10

15

20

25

30

35

40

45

50

55

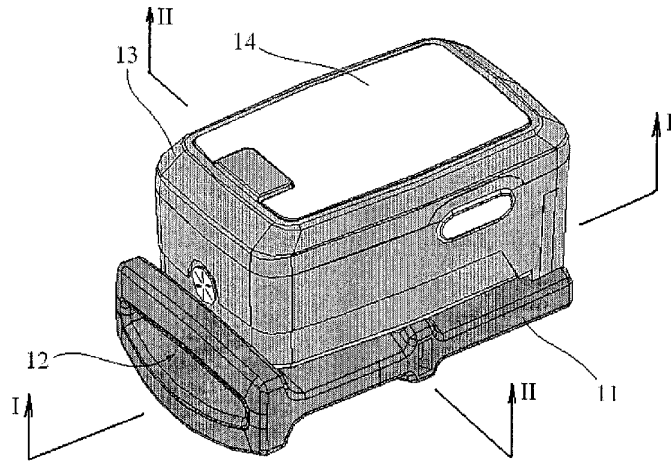

Fig. 1A

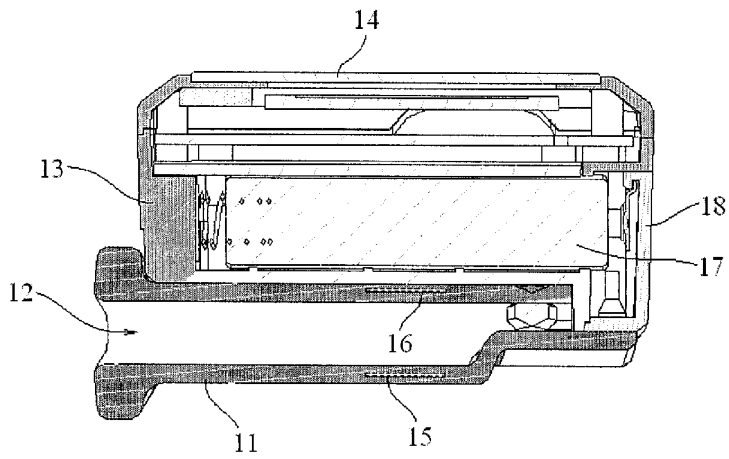

Fig.1B

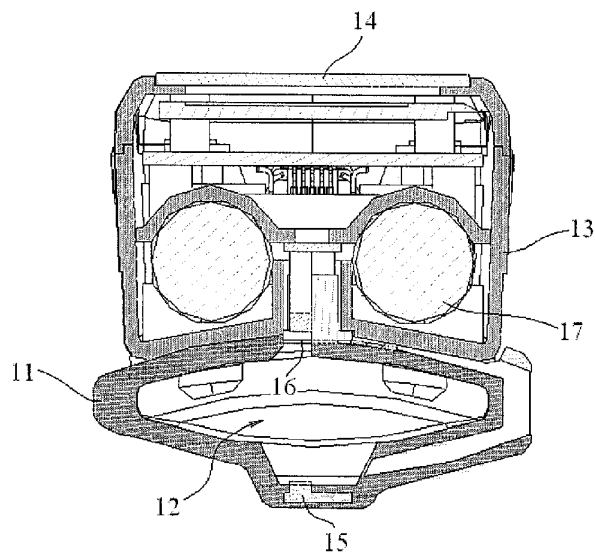

Fig.1C

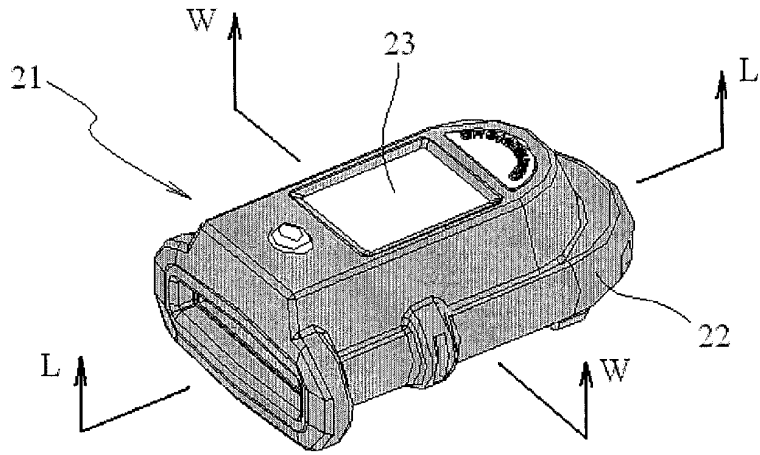

Fig.2A

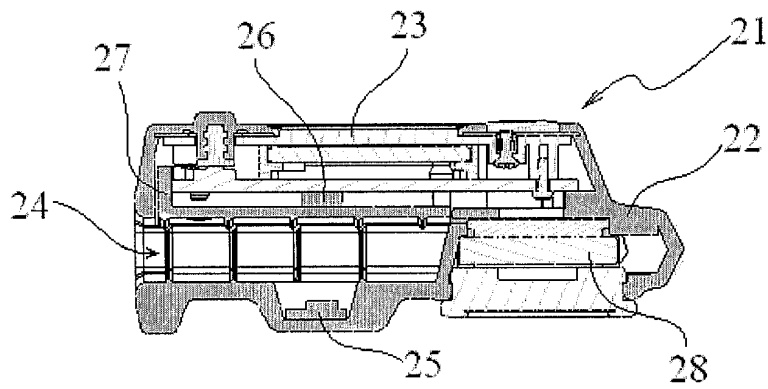

Fig.2B

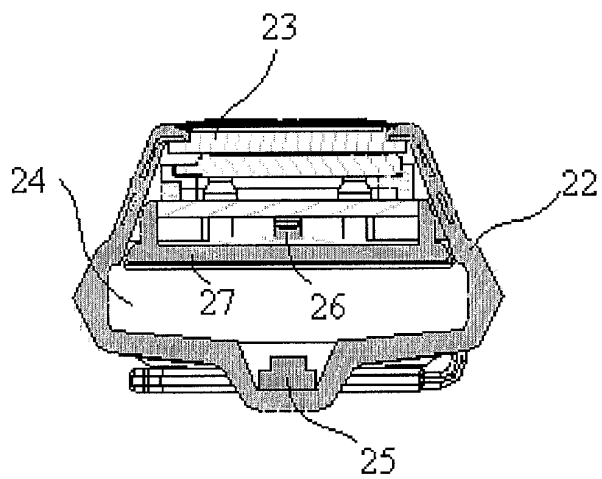

Fig.2C

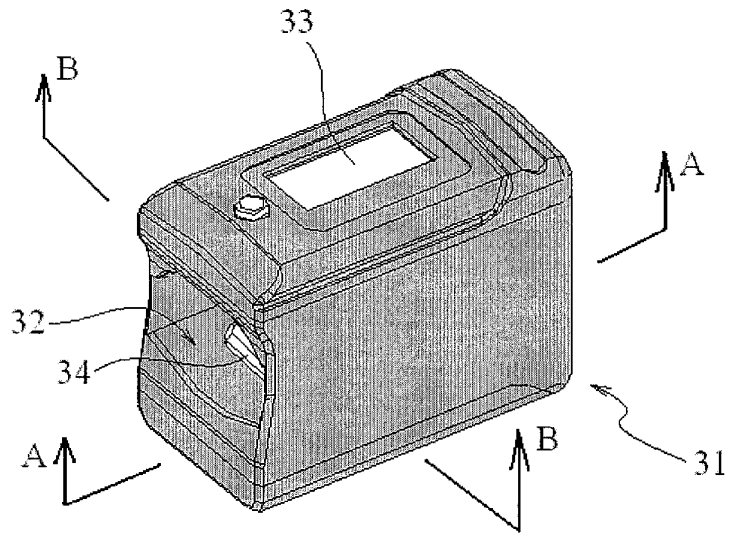

Fig.3A

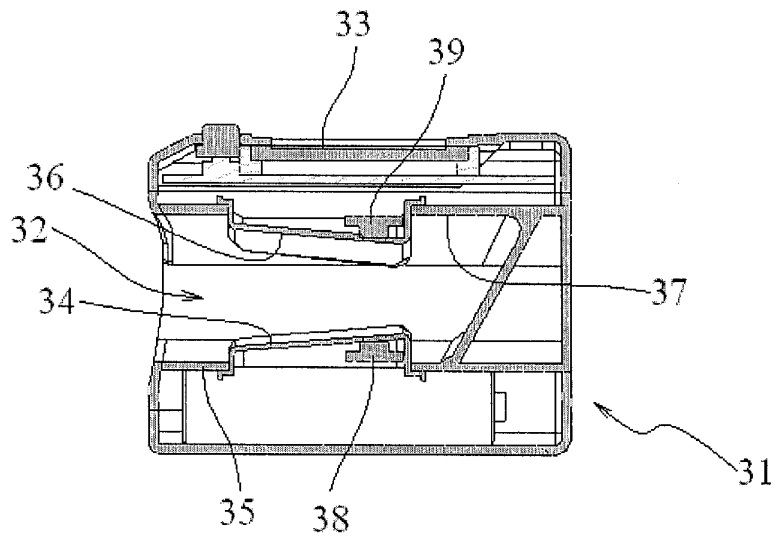

Fig.3B

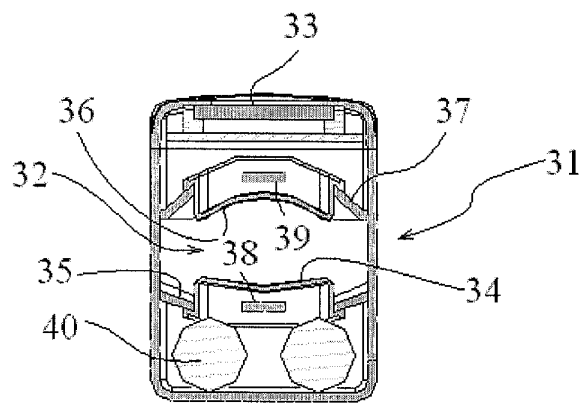

Fig.3C

INTERNATIONAL SEARCH REPORT

International application No.

PCT/CN2008/070412

A. CLASSIFICATION OF SUBJECT MATTER		
A61B5/145 (2006.01) i		
According to International Patent Classification (IPC) or to both national classification and IPC		
B. FIELDS SEARCHED		
Minimum documentation searched (classification system followed by classification symbols)		
IPC A61B		
Documentation searched other than minimum documentation to the extent that such documents are included in the fields searched		
Electronic data base consulted during the international search (name of data base and, where practicable, search terms used)		
CNPAT WPI EPODOC PAJ blood finger oxygen cot silica+ silicon elastic		
C. DOCUMENTS CONSIDERED TO BE RELEVANT		
Category*	Citation of document, with indication, where appropriate, of the relevant passages	Relevant to claim No.
Y	CN1141585A (MASIMO CORP), 29 Jan.1997 (29.01.1997), page 7, line 1 to page 14, line 14 in the specification, figures 4-16.	1-2,4
Y	CN2177449Y (FIRST MILITARY MEDICAL UNIVERS PLA), 21 Sep.1994 (21.09.1994), page 1, line 1 to 27 in the specification, figures 1-3.	1-2,4
A	JP2007-117641A (KONICA MINOLTA SENSING INC),17 May 2007 (17.05.2007), the whole document.	1-4
A	US5776059A (HEWLETT PACKARD CO),07 Jul. 1998 (07.07.1998), the whole document.	1-4
<input type="checkbox"/> Further documents are listed in the continuation of Box C. <input checked="" type="checkbox"/> See patent family annex.		
* Special categories of cited documents: "A" document defining the general state of the art which is not considered to be of particular relevance "E" earlier application or patent but published on or after the international filing date "L" document which may throw doubts on priority claim (S) or which is cited to establish the publication date of another citation or other special reason (as specified) "O" document referring to an oral disclosure, use, exhibition or other means "P" document published prior to the international filing date but later than the priority date claimed		"T" later document published after the international filing date or priority date and not in conflict with the application but cited to understand the principle or theory underlying the invention "X" document of particular relevance; the claimed invention cannot be considered novel or cannot be considered to involve an inventive step when the document is taken alone "Y" document of particular relevance; the claimed invention cannot be considered to involve an inventive step when the document is combined with one or more other such documents, such combination being obvious to a person skilled in the art "&" document member of the same patent family
Date of the actual completion of the international search 16 Sep. 2008(16.09.2008)		Date of mailing of the international search report 06 Nov. 2008 (06.11.2008)
Name and mailing address of the ISA/CN The State Intellectual Property Office, the P.R.China 6 Xitucheng Rd., Jimen Bridge, Haidian District, Beijing, China 100088 Facsimile No. 86-10-62019451		Authorized officer SUN,Xiaojing Telephone No. (86-10)62085632

Form PCT/ISA/210 (second sheet) (April 2007)

INTERNATIONAL SEARCH REPORT
 Information on patent family members

International application No.

PCT/CN2008/070412

Patent Documents referred in the Report	Publication Date	Patent Family	Publication Date
CN1141585A	29.01.1997	WO9502358A1	26.01.1995
		AU7361394A	13.02.1995
		EP0723417A1	31.07.1996
		JP9506786T	08.07.1997
		AU688352B	12.03.1998
		EP0723417B1	02.04.2003
		DE69432421E	08.05.2003
		CN1098053C	08.01.2003
		US5337744 A	16.08.1994
		CA2166069 A	26.01.1995
		US5452717 A	26.09.1995
		AT235855T	15.04.2003
		DE69432421T	12.02.2004
CN2177449Y	21.09.1994	None	
JP2007117641A	17.05.2007	None	
US5776059A	07.07.1998	DE19541605C2	24.06.1999
		DE19541605A1	15.05.1997

Form PCT/ISA/210 (patent family annex) (April 2007)

专利名称(译)	软指套血氧测量装置		
公开(公告)号	EP2201891A4	公开(公告)日	2013-07-10
申请号	EP2008715148	申请日	2008-03-21
[标]申请(专利权)人(译)	北京超思电子技术有限责任公司		
申请(专利权)人(译)	北京选择电子科技有限公司		
当前申请(专利权)人(译)	北京选择电子科技有限公司		
[标]发明人	WANG WEIHU		
发明人	WANG, WEIHU		
IPC分类号	A61B5/145 A61B5/1455 A61B5/00		
CPC分类号	A61B5/14552 A61B5/6826 A61B5/6838		
其他公开文献	EP2201891B1 EP2201891A1		
外部链接	Espacenet		

摘要(译)

本发明公开了一种没有枢轴结构的软胶指套式血氧计，软胶指套血氧计(21)包括软胶套(11)，其可以随手指轮廓的变化而紧密环绕手指，并且导致夹紧力分布在手指的被夹持部分上。发光电路板和接收电路板设置在软胶指(11)中。封装了血氧计(21)的软胶指(11)，其可以遮蔽从侧面进入的光。