

(19)



(11)

EP 2 120 681 B1

(12)

EUROPEAN PATENT SPECIFICATION

(45) Date of publication and mention of the grant of the patent:
13.07.2011 Bulletin 2011/28

(51) Int Cl.:
A61B 5/00 (2006.01) G01K 13/00 (2006.01)

(21) Application number: **08710063.2**

(86) International application number:
PCT/IB2008/050567

(22) Date of filing: **15.02.2008**

(87) International publication number:
WO 2008/110949 (18.09.2008 Gazette 2008/38)

(54) **METHODS AND DEVICES FOR MEASURING CORE BODY TEMPERATURE**

VERFAHREN UND VORRICHTUNGEN ZUR MESSUNG DER KÖRPERKERNTEMPERATUR

PROCÉDÉS ET DISPOSITIFS POUR MESURER LA TEMPÉRATURE CORPORELLE INTERNE

(84) Designated Contracting States:
AT BE BG CH CY CZ DE DK EE ES FI FR GB GR HR HU IE IS IT LI LT LU LV MC MT NL NO PL PT RO SE SI SK TR

(72) Inventor: **PADIY, Alexander, V.**
NL-5665 CK Geldrop (NL)

(30) Priority: **15.03.2007 US 894916 P**

(74) Representative: **Van Velzen, Maaïke Mathilde Philips**
Intellectual Property & Standards
P.O. Box 220
5600 AE Eindhoven (NL)

(43) Date of publication of application:
25.11.2009 Bulletin 2009/48

(73) Proprietor: **Koninklijke Philips Electronics N.V.**
5621 BA Eindhoven (NL)

(56) References cited:
EP-A- 0 310 101 WO-A-2004/001373
CA-A1- 2 538 940 US-A- 5 673 692
US-A1- 2006 189 884

EP 2 120 681 B1

Note: Within nine months of the publication of the mention of the grant of the European patent in the European Patent Bulletin, any person may give notice to the European Patent Office of opposition to that patent, in accordance with the Implementing Regulations. Notice of opposition shall not be deemed to have been filed until the opposition fee has been paid. (Art. 99(1) European Patent Convention).

Description

[0001] The following relates to the medical arts. It finds particular application in measuring core body temperature, and is described with particular reference thereto. However, the following finds more general application in measuring core body temperature-related values suitable for use in medical diagnostic, treatment monitoring, and related medical applications.

[0002] Core body temperature is an important medical vital sign. Unlike other vital signs such as heart rate or blood pressure, core body temperature is relatively insensitive to variations due to psychological or emotional state. Thus, core body temperature can be a good indicator of a medical problem. Moreover, a shift in core body temperature of only a few degrees Celsius away from the typical range can be life-threatening in and of itself, providing further motivation for monitoring this critical vital sign.

[0003] Unfortunately, core body temperature has heretofore been more difficult to measure than other vital signs such as heart rate or blood pressure. The core body temperature is defined as the temperature of blood flowing through the heart. However, for clinical purposes the core body temperature is typically taken as the brain temperature, since this value is typically close to the cardiac core temperature, and elevated brain temperature is a clinically serious condition that would be useful to monitor in clinical settings. As used herein, core body temperature is taken to correspond to the brain temperature. A rectal thermometer is also sometimes used to measure core body temperature, under the assumption that the rectal temperature is a suitable surrogate for the core body temperature. However, rectal temperature may differ substantially from core body temperature of the heart or brain. Insertion of a rectal thermometer is also uncomfortable for the patient, and rectal thermometry is not well-suited for extended monitoring over a period of hours, days, or longer.

[0004] To precisely measure core body temperature, a temperature sensor can be inserted into brain vasculature using a suitable catheter instrument. Although precise, this approach is clinically problematic because it is invasive and can produce disadvantageous side effects such as infection, vascular clotting, or so forth.

[0005] Core body temperature can also be estimated by measuring forehead temperature. This is the basis for the home diagnostic of placing a hand over the forehead of the patient to determine whether a fever is present. As a measure of core body temperature, this technique is inexact at best. A more precise core body temperature estimate can be obtained by placing a thermocouple, thermistor, or other electronic temperature sensor into contact with the forehead. However, the temperature acquired by such sensors can differ substantially from the core body temperature due to temperature drop across the skin and other intervening tissue. This temperature drop is not constant, but varies significantly as a function of sweat, room temperature, and other factors. The acquired temperature can also vary depending upon at what position on the forehead the sensor is placed.

[0006] Core body temperature is also sometimes estimated using an oral thermometer. It is known that placement of the thermometer in a posterior sublingual pocket provides a relatively accurate estimate of core body temperature, as this region is close to substantial arterial structure. However, even small errors in the positioning of the oral temperature can result in a substantial error in the temperature reading. Respiration, ingestion, or other oral activities can also adversely affect the temperature reading.

[0007] Thermometers are also known which are inserted into the ear canal to contact the tympanic membrane, also known colloquially as the ear drum. The tympanic membrane has relatively close proximity to the brain and reflects the core body temperature relatively accurately. However, the shape of the ear canal varies from person to person, and in some instances access to the tympanic membrane may be impeded or blocked by curvature of the ear canal. Another potential source of error is wax buildup in the ear canal. Physical contact with the tympanic membrane by the thermometer can also promote ear infection, which can be a serious medical condition. Core body temperature measurement via the tympanic membrane is also not well suited for extended monitoring over a period of hours, days, or longer.

[0008] Abreu, U.S. Published Application 2004/0059212, discloses a recently developed technique for measuring core body temperature that overcomes some of these difficulties. The approach of Abreu is based on identification of a thermally conductive pathway to the brain, called a "brain tunnel" in US 2004/0059212, located between the eyes proximate to an orbit or eye socket. By using contact thermometry at the location of this "brain tunnel," a relatively accurate core body temperature reading can be non-invasively obtained. Unfortunately, the identified brain tunnel has a small external cross-section near the eye orbit, which makes the accuracy of the core body temperature measurement strongly dependent upon precise placement of the temperature sensor. Positional deviations of as little as one or two millimeters can adversely affect the core body temperature measurement via the brain tunnel.

[0009] CA 2 538 940 A1 discloses a sensor array to measure the temperature. The sensor array is incorporated into a bandage and is fixed to a person's temple in use, preferably overlying a portion of the superficial temporal artery. The bandage carries a processing electronic to estimate the core body temperature based on the highest measured skin temperature. Further the bandage carries a transmitter. A second sensor array is incorporated into the bandage for estimation of the heat flow out of the skin.

[0010] US 2006/0189884 disclose a digital thermometer for measuring body temperature. The digital thermometer is designed to measure the temperature in the mouth of the user. This thermometer is designed to carry out single

measurements. It will generally take 10 to 30 seconds to reach the final temperature. Only temperatures under 43°C will be accepted.

[0011] WO 2004/001373 discloses support structure afor placement on the skin at the endof a brain tunnel. The support structure can be a modified nose pad or eyeglasses or a head mounted gear. The support structure comprises a sensor for measurement of the brain temperature.

[0012] While acquisition of an accurate core body temperature reading is difficult, extended monitoring of this vital sign is more difficult still. As noted above, suitable sites for measuring core body temperature, such as the posterior sublingual pocket and the "brain tunnel" identified by Abreu, are typically small. As a result, shift or movement of the temperature sensor over time during extended monitoring is problematic.

[0013] The invention as defined in the independent claims provides new and improved apparatuses and methods which overcome the above-referenced problems and others.

[0014] In accordance with one aspect, a core body temperature measurement device includes a plurality of electronic temperature sensors operatively coupled with or near a surface having a surface temperature approximating the core body temperature, and a readout controller including a maximum temperature reading selector. The readout controller is configured to acquire temperature readings using the plurality of temperature sensors and to output a core body temperature based on a highest usable temperature reading of the acquired temperature readings as determined by the maximum temperature reading selector, optionally also including a correction for the temperature drop through the skin as will be described in more detail in the sequel.

[0015] In accordance with another aspect, a core body temperature measurement device includes at least one electronic temperature sensor operatively coupled with or near a surface having a surface temperature approximating the core body temperature, and a readout controller configured to acquire an input temperature reading from the at least one electronic temperature sensor and to obtain a core body temperature therefrom. The readout controller includes a temperature corrector that increases the input temperature reading to account for a temperature difference between the input temperature reading and the core body temperature.

[0016] In accordance with another aspect, a core body temperature measurement method includes: acquiring a plurality of temperature readings at and near a surface having a surface temperature approximating the core body temperature; generating a highest usable temperature reading from the acquired temperature readings; and outputting a core body temperature based on the highest usable temperature.

[0017] One advantage resides in providing an accurate non-invasive core body temperature measurement.

[0018] Another advantage resides in providing a non-invasive core body temperature measurement that is relatively insensitive to the precise positioning of the temperature measurement device.

[0019] Another advantage resides in providing a non-invasive core body temperature measurement that is corrected for a temperature difference between the surface at which the temperature is measured and the body core.

[0020] Still further advantages of the present invention will be appreciated to those of ordinary skill in the art upon reading and understand the following detailed description.

FIGURE 1 diagrammatically shows a side view of a human head with the skin and other outer tissue removed to reveal arteries of the right side of the face and scalp, and further indicating preferred locations for acquiring non-invasive core body temperature measurements.

FIGURE 2 diagrammatically shows a side view of a human neck supporting a partially turned human head, with the skin and other outer tissues partially removed to reveal arteries of the right side of the neck and head, and further indicating preferred locations for acquiring non-invasive core body temperature measurements.

FIGURE 3 diagrammatically shows a readout controller for a core body temperature measurement device.

FIGURE 4 diagrammatically shows a maximum temperature reading selector.

FIGURE 5 diagrammatically shows an array of temperature sensors encompassing a brain tunnel location.

FIGURE 6 diagrammatically shows an interpolated temperature reading surface acquired by the array of temperature sensors positioned as shown in FIGURE 5.

FIGURE 7 diagrammatically shows an array of temperature sensors to the left of a brain tunnel location.

FIGURE 8 diagrammatically shows an interpolated temperature reading surface acquired by the array of temperature sensors positioned as shown in FIGURE 8.

FIGURE 9 diagrammatically shows a combination temperature/heat flux sensor.

FIGURE 10 diagrammatically shows a core body temperature measurement device including a mechanical frame in the form of an eyeglasses frame.

FIGURE 11 diagrammatically shows a core body temperature measurement device including a mechanical frame in the form of a behind-the-head pillow having extensions configured to loop over the left and right auricles.

FIGURE 12 diagrammatically shows a core body temperature measurement device including a mechanical frame in the form of headset including an earloop disposed around a proximate auricle without a headband.

FIGURE 13 diagrammatically shows a core body temperature measurement device including a mechanical frame

in the form of a circumferential headband.

FIGURE 14 diagrammatically shows a core body temperature measurement device including a mechanical frame in the form of a generally hemispherical headband.

FIGURE 15 diagrammatically shows a core body temperature measurement device including a mechanical frame in the form of an adhesive pad.

FIGURE 16 diagrammatically shows an oral thermometer including a plurality of electronic temperature sensors.

[0021] With reference to FIGURES 1 and 2, as used herein core body temperature is taken to correspond to the brain temperature. It is advantageous to measure core body temperature at a surface having a surface temperature approximating the core body temperature. For example, Abreu U.S. Published Application 2004/0059212, discloses measuring core body temperature at a thermally conductive pathway to the brain, called a "brain tunnel" in US 2004/0059212, located between the eyes proximate to an orbit or eye socket. This location is indicated in FIGURES 1 and 2 as the "between-the-eyes" location **BTT**. Another previously identified surface having a surface temperature approximating the core body temperature is the sublingual pocket (not visible in FIGURES 1 and 2) inside of the mouth. A posterior or rear of a sublingual pocket has been found to have a surface temperature approximating the core body temperature.

[0022] With continuing reference to FIGURES 1 and 2, it is recognized herein that skin overlaying arterial blood-rich superficial regions disposed near an auricle define other surfaces having a surface temperature approximating the core body temperature. The auricle, also known as the pinna, is the outer, projecting portion of the ear, that is, the visible part of the ear that resides outside of the head. The superficial temporal artery is positioned forward of the auricle and carries arterial blood from the external carotid artery outward toward the surface of the scalp in front of the auricle. Accordingly, a temperature measurement device may be operatively coupled with skin overlaying a portion of a superficial temporal artery disposed anterior (that is, in front of) the auricle, such as at a region **STA** indicated in FIGURES 1 and 2. As another example, arterial vessels disposed behind the auricle, such as the posterior auricular artery, carry arterial blood from the external carotid artery outward toward the surface of the scalp behind the ear. Accordingly, a temperature measurement device may be operatively coupled with skin overlaying a portion of an artery ascending posterior to (that is, behind) the auricle, such as at the region **PAA** indicated in FIGURES 1 and 2.

[0023] While FIGURES 1 and 2 show the configuration of the aforementioned arteries, auricle, and other anatomical features for the right auricle, it is to be understood that bilateral symmetry pertains, and similar core body temperature measurement positions exist for the left auricle as well. Indeed, in some embodiments core body temperature measurements are acquired from regions disposed near both the left and right auricles.

[0024] With reference to FIGURE 3, a suitable readout controller **10** for a core body temperature measurement device is described. The readout controller **10** reads temperature measurements using an electronic temperature sensor or, in some embodiments, a plurality of electronic temperature sensors **12**, that are thermally coupled with a surface having a surface temperature approximating the core body temperature. For example, the electronic temperature sensors **12** may be coupled with the region **STA** of FIGURES 1 and 2, the region **PAA** of FIGURES 1 and 2, the region **BTT** of FIGURES 1 and 2, the sublingual pocket inside the mouth (not shown in FIGURES 1 and 2), or some combination of these locations. An advantage of providing the plurality of temperature sensors **12**, rather than a single temperature sensor, is that the plurality of temperature sensors **12** can sample different portions of the skin or other surface. The precise location of the region **STA**, region **PAA**, region **BTT**, the sublingual pocket, or so forth, may vary from person to person and may be difficult to locate precisely on a given subject.

[0025] Using the plurality of temperature sensors **12** accommodates such individual variation. A maximum reading selector **14** selects the highest temperature measurement acquired by the plurality of temperature sensors **12** as a highest usable temperature reading **15** for determining the core body temperature. This approach relies on the recognition made herein that the measured temperature should be highest at that point where the skin temperature most closely approximates the core body temperature. Lower temperature measurements generally reflect higher thermal losses away from the surface having a surface temperature approximating the core body temperature. Lower temperature measurements may also reflect inaccurate temperature readings due to poor thermal contact of the temperature sensor with the skin or other measurement errors. Thus, by using the plurality of temperature sensors **12** and employing the maximum reading selector **14** to select the highest temperature measurement, such difficulties are alleviated.

[0026] With brief reference to FIGURES 4-6, in some embodiments the maximum temperature reading selector **14** uses a more complex algorithm for determining the highest usable temperature from which the core body temperature is determined. FIGURE 4 shows an embodiment of the maximum reading selector **14** that includes an interpolator **14a** for spatially interpolating the acquired temperature readings, and a peak detector **14b** for identifying the peak interpolated temperature as the highest usable temperature reading **15**.

[0027] FIGURES 5 and 6 illustrate this approach further. FIGURE 5 shows an example surface thermal profile of the skin surface at and near to the "brain tunnel" **BTT**. In FIGURE 5, the surface thermal profile is indicated by grayscale shading, with darker shading corresponding to higher temperature. The dark central position of the surface thermal profile corresponds to the center of the "brain tunnel" **BTT**, where the surface temperature is closest to the core body

temperature. At positions increasingly further away from the "brain tunnel" **BTT**, there is generally more thermal loss across intervening tissue such as skin or fat, resulting in a lower surface temperature. The plurality of temperature sensors **12** in FIGURE 5 comprises a 6×7 rectangular array, with each temperature sensor diagrammatically indicated in FIGURE 5 by a filled circle. Arrays with other numbers of sensors, and optionally arranged in other ways, are also contemplated.

[0028] FIGURE 6 plots a two-dimensional interpolated temperature surface $T_s(x,y)$ generated by the interpolator **14a** from the temperature readings acquired by the plurality of temperature sensors **12** positioned respective to the brain tunnel location **BTT** as shown in FIGURE 5. The interpolation may be done using a piece-wise constant interpolation algorithm, a piece-wise linear interpolation algorithm, a piece-wise quadratic interpolation algorithm, a higher-order interpolation algorithm, or so forth. The peak detector **14b** suitably determines the highest usable temperature T_{max} as the value of the interpolated temperature surface $T_s(x,y)$ at which the gradient ∇T_s of the two-dimensional temperature surface goes to zero. That is, the peak detector **14b** determines $T_{max}=Ts(x_o,y_o)$ where $\nabla T_s|(x_o,y_o)=0$.

[0029] With returning reference to FIGURE 4 and with further reference to FIGURES 7 and 8, if the peak detector **14b** fails to identify a peak at which the derivative or gradient goes to zero, this may indicate that the plurality of temperature sensors **12** does not encompass the "brain tunnel" **BTT** or other maximum temperature point on the surface where the surface temperature most closely approximates the core body temperature. In FIGURE 7, the array of temperature sensors **12** is positioned too far to the left of the brain tunnel **BTT**, such that it does not encompass the brain tunnel **BTT**. FIGURE 8 shows the corresponding interpolated temperature surface $T_s(x,y)$, which in this case does not have any peak at which ∇T_s goes to zero. Thus, the peak detector **14b** outputs a "no peak" result **14c** which is suitably used to issue an error warning **14d**. Optionally, "no peak" result **14c** includes an indication of the position of the highest temperature of the interpolated temperature surface $Ts(x,y)$, and the error warning **14d** includes a suggestion to move the temperature measurement device in the direction of the position of highest temperature. In the illustrative example of FIGURES 7 and 8, the highest temperature is at the right of the array of temperature sensors **12**, and so the error warning **14d** would suggest moving the temperature measurement device to the right.

[0030] On the other hand, if multiple peaks are located (that is, if $\nabla T_s=0$ at more than one position) then the highest interpolated temperature of the multiple peaks is suitably defined as T_{max} . For example, if $\nabla T_s(x_1,y_1)=0$ and $Ts(x_1,y_1)=37.4^\circ\text{C}$, while $\nabla T_s(x_2,y_2)=0$ and $Ts(x_2,y_2)=37.1^\circ\text{C}$, then selection of $T_{max}=37.4^\circ\text{C}$ is appropriate.

[0031] In the embodiments described with reference to FIGURES 5-8, the plurality of temperature sensors **12** is arranged two-dimensionally. In other embodiments, the plurality of temperature sensors **12** may have a linear, curvilinear, or other one-dimensional arrangement. In such embodiments, the interpolator **14a** suitably generates an interpolated one-dimensional temperature-versus position curve (e.g., $T_s(x)$) rather than the two-dimensional surface $T_s(x,y)$, and the gradient ∇T_s for such a one-dimensional curve has the form of a one-dimensional derivative (e.g., $\nabla T_s=dTs/dx$).

[0032] Still further, the maximum reading selector **14a**, **14b** illustrated in FIGURE 4 is an example. In another suitable embodiment, the maximum reading selector **14** determines the maximum usable temperature as the maximum temperature reading acquired by any of the temperature sensors **12**, except that any temperature above an outlier threshold is discarded. For example, the outlier threshold may be set at 43°C , since a temperature reading that high is not likely to be physically correct for a living human subject. This approach advantageously omits from consideration any unrealistic or non-physical temperature readings, such as might result from a malfunctioning temperature sensor of the plurality of temperature sensors **12**. Such outlier exclusion can also be used in conjunction with the maximum temperature reading selector **14a**, **14b** of FIGURE 4. Although the approach using the plurality of temperature sensors **12** has advantages, it is also contemplated to employ a single temperature sensor to acquire a single temperature measurement, and to omit the maximum reading selector **14**.

[0033] With returning reference to FIGURE 3, a temperature corrector **16** optionally increases the highest usable temperature reading **15** to account for a temperature drop across the skin, so as to more accurately determine the core body temperature. Alternatively, such a correction can be made to the temperature readings acquired by the plurality of temperature sensors **12** before input to the maximum temperature reading selector **14**. In one approach, this correction is made by adding a fixed amount, such as 1°C , to the highest usable temperature reading **15** to provide an estimated correction for the temperature drop due to thermal losses in the skin. This approach is computationally straightforward, but can lead to some error since the actual skin temperature drop varies based on factors such as moisture (e.g., sweat), ambient temperature, air convection, and so forth. More computationally elaborate skin temperature drop corrections can be used, as described later herein. Moreover, the temperature corrector **16** can correct for other factors that may affect the accuracy of the core body temperature measurement. For example, if the electronic temperature sensors **12** are thermocouples, the temperature corrector **16** may include a correction for non-linearity of the temperature-versus-thermocouple voltage characteristic. The output of the temperature corrector **16** is the core body temperature.

[0034] Optionally the temperature measurement device includes sensors to acquire other physiological parameters besides temperature. For example, a blood oxygen sensor **20**, such as an SpO_2 sensor or an StO_2 sensor, acquires a measurement (typically an optically based measurement in the case of an SpO_2 or StO_2 sensor) that is converted into a blood oxygenation level reading and a pulse reading by a pulse/oxygen extractor **22**. Different or additional sensors

can be included, such as a blood pressure sensor.

[0035] The resulting information including the core body temperature and optional other readings such as blood oxygenation and pulse are output by a suitable output path such as a built-in display (not shown in FIGURE 3), a wired connection, an illustrated wireless transmitter **24** or transceiver that outputs a wireless data signal **26**, or so forth. The core body temperature measurement device optionally includes other features. For example, if the core body temperature data is offloaded from the temperature measurement device using a wired connection, then the wired connection can incorporate a power input lead to power the sensors **12**, **20** and processor **10**. Alternatively, if the illustrated wireless transmitter **24** or transceiver is used such that the core body temperature measurement device is a wireless device, then an on-board battery **28**, power capacitor, or other on-board electrical power supply is suitably included.

[0036] As mentioned previously, the optional skin temperature corrector **16** in some embodiments employs an estimated skin temperature drop correction, such as a 1°C temperature drop correction. This approach is computationally straightforward, but can lead to some error since the actual skin temperature drop varies based on factors such as moisture (e.g., sweat), ambient temperature, air convection, and so forth. To accommodate such factors, in some embodiments the skin temperature corrector **16** employs a more complex corrective approach based on feedback. Some suitable temperature correction algorithms are disclosed in Fox et al., U.S. Patent No. 3,933,045 which is incorporated herein by reference; Heikkilä et al, U.S. Patent No. 5,816,706 which is incorporated herein by reference; and Tokita et al., U.S. Patent No. 6,886,978 which is incorporated herein by reference.

[0037] One suitable temperature correction algorithm operates in conjunction with the one or more skin temperature sensors **12** each configured to include parallel conductive plates or films spaced apart by a distance that is adjustable using inchworm actuators, MEMS actuators, or so forth. These temperature sensors are in effect combination temperature/heat flux sensors, because by acquiring temperature measurements across the two plates at different plate separations, the heat flux can be determined, from which the skin temperature drop can in turn be estimated. Designating the temperatures of the two conductive plates as T_1 and T_2 , respectively, and the core body temperature as T_{core} , the following expression holds:

$$\frac{dT}{dt} = \alpha \frac{d^2T}{dx^2} \quad (1),$$

where $\alpha = \lambda/\rho c_p$, λ denotes thermal conductivity, ρ denotes density, and c_p denotes specific heat. In a suitable coordinate system, x denotes depth with $x=0$ corresponding to a point inside the body at temperature T_{core} and $x=h_s$ corresponding to the surface of the skin. The boundary conditions for Equation (1) include the core body temperature T_{core} (to be determined) at $x=0$, and the measured temperature T_s at $x=h_s$, that is, at the surface of the skin. If the conductive plate at temperature T_2 is contacting or otherwise in good thermal communication with the skin, then $T_s=T_2$ to a good approximation. The heat flux out of the skin is denoted q_s herein.

[0038] Assuming the skin **33** can be represented as a plane of thickness h_s and thermal conductivity λ_s , the heat flux out of the skin q_s (that is, heat transfer rate on a per-unit area basis) can be written as:

$$q_s = -\lambda \frac{dT}{dx} \quad \text{at } x = h_s \quad (2),$$

and a solution of Equation (1) can be approximated as:

$$T_{core} = T_s + \frac{h_s}{\lambda_s} q_s + \frac{h_s^2}{2\alpha_s} \frac{dT_s}{dt} \quad (3).$$

At equilibrium, Equation (3) reduces to:

$$T_{core} = T_s + \frac{h_s}{\lambda_s} q_s \quad (4),$$

which demonstrates that the core body temperature T_{core} is higher than the skin temperature by a temperature drop across the skin corresponding to $(h_s/\lambda_s) \cdot q_s$.

[0039] By using feedback control of actuators separating the parallel conductive plates or films, the values of the quantities T_s , q_s , and can be measured for different moments in time $t_i = \{t_1, \dots, t_n\}$ to produce a matrix of coupled equations:

5

10

$$\begin{bmatrix} 1 & -\xi_1 & -\eta_1 \\ & \dots & \\ 1 & -\xi_n & -\eta_n \end{bmatrix} \begin{bmatrix} T_{core} \\ \frac{h_s}{\lambda_s} \\ \frac{h_s^2}{2\alpha_s} \end{bmatrix} = \begin{bmatrix} T_s(t_1) \\ \vdots \\ T_s(t_n) \end{bmatrix} \quad (5),$$

15

in which the unknown quantities are T_{core} , $\frac{h_s}{\lambda_s}$ and $\frac{h_s^2}{2\alpha_s}$, and where:

20

$$\xi \equiv q_s(t_i) \quad (6),$$

and

25

$$\eta \equiv \frac{dT_s}{dt}(t_i) \quad (7).$$

30

It is assumed here that T_{core} , $\frac{h_s}{\lambda_s}$ and $\frac{h_s^2}{2\alpha_s}$ are time-independent during the time interval $\{t_1, \dots, t_n\}$ over which the set of measurements are acquired. The system of Equations (5) can be solved by the temperature corrector **16** using a least squares minimisation procedure or other suitable coupled equations solver to provide the body core temperature T_{core} , and also the heat flux q_s through the surface of the skin. The sampling moments t_i are suitably chosen such that to ensure that the system of Equations (5) is well-conditioned.

35

[0040] In some embodiments, the heat flux across the parallel conductive plates of a parallel-plate temperature/heat flux sensor is determined by a combination of thermal and electrical measurements. This approach makes use of a formal correspondence identified herein between the electrostatic potential distribution given by Poisson's equation ($\epsilon \cdot \nabla^2 \phi = 0$) and the expression for temperature distribution ($k \cdot \nabla^2 T = 0$). Comparing these equations and using the boundary conditions $\phi|_{\Omega_1} = \phi_1$ and $T|_{\Omega_1} = T_1$ at the conductive plate arranged distal from the skin having a surface designated Ω_1 and $\phi|_{\Omega_2} = \phi_2$ and $T|_{\Omega_2} = T_2 = T_s$ at the conductive plate contacting the skin having a surface designated Ω_2 , it can be

40

shown that $\eta_T = \left(\frac{k}{\epsilon}\right) C$, where η_T is the thermal conductance between the two spaced-apart conductive plates, C is

45

the mutual capacitance of the two spaced-apart conductive plates, k is the thermal conductivity of the dielectric material spacing apart the conductive plates, and ϵ is the dielectric constant of the dielectric material spacing apart the conductive plates. In deriving this relationship between thermal conductance η_T and mutual capacitance C , it is assumed that the ratio k/ϵ is a constant. This assumption holds sufficiently for air, foam, polyethylene, and numerous other common dielectric spacers. The dielectric constant or permittivity ϵ of the dielectric spacer is related to the vacuum permittivity $\epsilon_0 \approx 8.8542 \times 10^{-12}$ F/m by the relative dielectric constant according to the relationship $\epsilon = \epsilon_r \cdot \epsilon_0$.

50

[0041] FIGURE 9 shows a suitable temperature/heat flux sensor making use of this capacitance/thermal conductance relationship. Two conductive plates **30**, **31** are spaced apart by a dielectric material **32**. The conductive plate **31** is in thermal contact with skin **33**. Actuators **34** such as piezoelectric elements, inchworm elements, or so forth, enable electrically driven control of the separation of the conductive plates **30**, **31**. In this embodiment, the temperatures T_1 , T_2 of the respective conductive plates **30**, **31** are measured by respective thermocouples **35**, **36** or other suitable temperature

55

transducers, and the mutual capacitance C of the plates **30, 31** is measured by a capacitance meter **37**. The temperatures T_1, T_2 and the mutual capacitance C for each of the temperature sensors **12** is input to the controller **10**, where the temperature corrector **16** is configured to apply the temperature correction set forth referencing Equations (1)-(7) and

making use of the heat flux $f = (T_1 - T_2) \cdot \eta_T = (T_1 - T_2) \cdot \left(\frac{k}{\epsilon}\right) \cdot C$. The relationship $\eta_T = \left(\frac{k}{\epsilon}\right)$ enables the heat

flux f across the parallel plates **30, 31** to be determined for the known (measured) T_1 and T_2 by a straightforward mutual capacitance measurement using a capacitance meter, from which the heat flux across the skin can be estimated.

Advantageously, the geometrical assumptions going into derivation of the relationship $\eta_T = \left(\frac{k}{\epsilon}\right) \cdot C$ are limited - for

example, spaced apart conductive bodies that are not parallel plates can be used. In the combination temperature/heat flux sensor of FIGURE 9, for example, the conductive plate **30** includes a pin or other protrusion **38** that decreases the plate separation distance and increases measurement sensitivity. Alternatively, one or more such pins or protrusions can be included on the plate **31**, or on both plates **30, 31**.

[0042] As another approach, the temperature corrector **16** can make a skin temperature drop correction determined based on physiological measurements such as the ambient temperature (suitably acquired using a temperature sensor that is not in contact with or close to the skin), skin sheet resistance or conductivity (measurable using a first electrode pair driving a small current and a second electrode pair measuring voltage generated by the drive current), or so forth. A lookup table or empirical formula suitably relates the skin temperature drop correction to the measured ambient temperature, skin sheet resistance, or other parameters.

[0043] In some contemplated embodiments of the temperature corrector **16**, the corrective approach of Tokita et al, U.S. Patent No. 6,886,978 is used, in which a variable heater provides a perturbation of the temperature distribution from which the core body temperature can be estimated. In this approach, the temperature distribution can be written for the sensor of FIGURE 9 as $(dT/dx) = a \cdot (T_{core} - T_2) - b \cdot (T_2 - T_1)$ where a and b are constants and T_{core} is the core body temperature. This relationship is derived in Tokita (note that the notation of Tokita reverses T_1 and T_2 versus FIGURE 9). The sensor of FIGURE 9 is used to acquire the data set $(T_1, T_2, dT/dx)$ for several different heating levels provided by the variable heater, producing a set of equations that can be solved simultaneously to obtain the parameters a, b , and T_{core} . In some suitable embodiments, an optical source of the blood oxygen sensor **20** provides variable heating for this purpose. For example, a SpO₂ sensor typically includes a semiconductor laser, LED, or other optical source for acquiring the SpO₂ reading - the optical source can also be operated at different power levels to provide variable heating for core body temperature measurement using the sensor of FIGURE 9 and the skin temperature drop correction as set forth in Tokita. In some such embodiments, the sensor of FIGURE 9 is modified by omission of the pin **38**, so that a well-defined planar geometry is provided. In other embodiments, the pin **38** is retained along with the capacitance meter **37**,

and the relation $\eta_T = \left(\frac{k}{\epsilon}\right)$ is used to derive the heat flux between the plates **30, 31** from which along with T_1 and T_2

the derivative dT/dx is determined. Additionally, the actuators **34** can be omitted in these embodiments in which thermal (i.e., heating) perturbation is used instead of mechanical perturbation. With the actuators **34** omitted, the spacing of the conductive layers or plates **30, 31** is not modifiable.

[0044] With reference to FIGURES 10-15, several head-mountable mechanical frames are set forth as illustrative examples of ways of mounting temperature sensor arrays to one or both of the surfaces **STA, PAA** shown in FIGURES 1 and 2 and having surface temperature approximating the core body temperature. The use of a head mountable mechanical frame facilitates extended monitoring of core body temperature.

[0045] FIGURE 10 diagrammatically shows a core body temperature measurement device **40** including a mechanical frame in the form of an eyeglasses frame **42**. The eyeglasses frame **42** can contain prescriptive lenses for correcting eyesight, or can contain non-corrective lenses, or can have no lenses at all. A first set of temperature sensors **12f** are mounted near the left and right bends of the frame and are operatively coupled with skin overlaying portion of the superficial left and right temporal arteries anterior to the left and right auricles. A second set of temperature sensors **12b** are mounted near the left and right earpieces and are operatively coupled with skin overlaying portions of left and right arteries ascending posterior to the left and right auricles. The temperature sensors **12f, 12b** are mounted on supports **44** that each include a spring bias **46** coupling the support to the eyeglasses frame and pressing the supported temperature sensors against the skin overlaying the target arterial blood-rich superficial region. The readout controller is suitably embodied by microchips **48** disposed on the eyeglasses frame **42** as illustrated.

Wired connections **50** provide power to the microchips **48** and sensors **12f, 12b** and provide a pathway for offloading the acquired core body temperature measurements and optional blood oxygenation or other measurements. A wireless

implementation of the described solution is also contemplated.

[0046] FIGURE 11 diagrammatically shows a core body temperature measurement device **60** including a mechanical frame in the form of a behind-the-head pillow **62** having extensions **64** configured to loop over the left and right auricles (only the right-side extension **64** is visible in FIGURE 11). One or more temperature sensors are mounted on one or more supports **66** disposed on one or both extensions **64**. Optionally, a microchip **68** defining the readout controller **10** is disposed on or in the behind-the-head pillow **62** and operatively connects with the temperature sensors on the supports **66** via wires (not shown) running inside of or along the extensions **64**.

[0047] FIGURE 12 diagrammatically shows a core body temperature measurement device **70** including a mechanical frame in the form of headset including an earloop **72** disposed around a proximate auricle without a headband. The illustrated embodiment includes a first temperature sensor support **74** disposed anterior to the right auricle and coupling one or more temperature sensors with skin overlaying a portion of the right superficial temporal artery, and a second temperature sensor support **76** disposed posterior to the right auricle and coupling one or more temperature sensors with skin overlaying a portion of an artery ascending posterior to the right auricle. The illustrated core body temperature measurement device **70** is a wireless device, and accordingly includes the readout controller **10** (FIGURE 3) with the on-board battery **28** or other on-board power source and wireless transmitter **24** or transceiver mounted on the earloop **72**. Some suitable on-board power devices and transmitters are known and used in existing wireless Bluetooth headsets that are sometimes embodied as earloops.

[0048] FIGURE 13 diagrammatically shows a core body temperature measurement device **80** including a mechanical frame in the form of a circumferential headband **82** with one or more supports for one or more temperature sensors disposed on the circumferential headband proximate to one or both auricles and contacting skin overlaying one or more arterial blood rich superficial regions disposed near the proximate auricle or auricles. In the illustrated embodiment, a front support **84** is disposed anterior to the right auricle and couples one or more temperature sensors with skin overlaying a portion of the right superficial temporal artery, and a back temperature sensor support **86** is disposed posterior to the right auricle and couples one or more temperature sensors with skin overlaying a portion of an artery ascending posterior to the right auricle. Optionally, corresponding supports for temperature sensors are also provided proximate to the left auricle. A wired connection **88** extends from an under-the-chin readout controller **90** for offloading core body temperature measurements and optionally other measurements, and for supplying electrical power to the device **80**. The under-the-chin readout controller **90** suitably has a configuration similar to that of the controller of FIGURE 3.

[0049] FIGURE 14 diagrammatically shows a core body temperature measurement device **100** including a mechanical frame in the form of a generally hemispherical headband **102** having an end with a temperature sensor support **104** disposed anterior to the right auricle and coupling one or more temperature sensors with skin overlaying a portion of the right superficial temporal artery. The readout controller is suitably mounted on top of the hemispherical head **102** (not shown in the perspective view of FIGURE 14) and optionally includes the wireless transmitter **24** or transceiver.

[0050] FIGURE 15 diagrammatically shows a core body temperature measurement device **110** including a mechanical frame in the form of an adhesive pad **112** adhered to contact skin overlaying a portion of the right superficial temporal artery. One or more temperature sensors are suitably disposed on, under, or in the adhesive pad **112** in thermal communication with the skin. In the illustrated embodiment, a rigid disk **114** contains the one or more temperature sensors along with a readout controller suitably conforming with the readout controller **10** of FIGURE 3.

[0051] The mechanical frames illustrated in FIGURES 10-15 are examples. Other head-mounted mechanical frames may be used that are configured to operatively couple one or more temperature sensors with a surface having a surface temperature approximating the core body temperature. For example, some of the mechanical frames shown in Abreu, U.S. Published Application 2004/0059212 for coupling a temperature sensor with the "brain tunnel" **BTT** of Abreu are readily adapted to support an array or other plurality of temperature sensors.

[0052] With reference to FIGURE 16, the core body temperature measurement approaches disclosed herein may be practiced in other ways besides through the use of a head-mountable mechanical frame. For example, FIGURE 16 shows a hand-held oral thermometer **120** having a body that includes a handle **122** containing a microchip **124** or other element or combination of elements embodying the controller **10** (see FIGURE 3), a neck **126**, and a generally spherical sensors head **128** supporting an array or other plurality of sensors **132**. The handle **122** and neck **126** enable a physician, nurse, or other person to insert the generally spherical sensors head **128** into a subject's mouth, preferably in a sublingual pocket inside of the mouth, and more preferably in a posterior or rear region of a sublingual pocket inside of the mouth. The temperature readout from the controller **10** is suitably displayed via a built-in LCD display **134**, or can be offloaded from the thermometer **120** via a wireless or wired connection (not shown in FIGURE 16).

[0053] The provision of a plurality of temperature sensors **132** (represented by filled circles in FIGURE 16) distributed over the generally spherical sensors head **128**, along with a suitable implementation of the maximum temperature reading selector **14** in the controller **10**, substantially improves the likelihood that an accurate temperature reading will be obtained even if there is substantial mispositioning of the generally spherical sensors head **128** in the sublingual pocket. The combination of a plurality of temperature sensors **132** and the maximum temperature reading selector **14** also provides robustness against individual anatomical variations that may result in unusual subject-specific arterial

configurations proximate to the sublingual pocket, or unusual subject-specific sublingual pocket geometries. For the purposes of temperature interpolation, the spatial arrangement of the plurality of temperature sensors **132** is suitably represented as a surface in a spherical coordinates system, or as a Cartesian surface approximately wrapped around the generally spherical sensors head **128**, or the like. Because some of the spherical area is occupied by the connection of the neck 126 to the generally spherical sensors head **128**, the plurality of temperature sensors **132** generally do not span an entire sphere. Moreover, it is contemplated for the generally spherical sensors head **128** to be ellipsoidal or otherwise-shaped.

[0054] The invention has been described with reference to the preferred embodiments. Modifications and alterations may occur to others upon reading and understanding the preceding detailed description. It is intended that the invention be construed as including all such modifications and alterations insofar as they come within the scope of the appended claims.

Claims

1. A core body temperature measurement device comprising:

at least one electronic temperature sensor (12, 12f, 12b, 132) operatively coupled with or near a surface (STA, PAA, BTT) having a surface temperature approximating the core body temperature; and a readout controller (10, 48, 68, 90, 124) configured to acquire an input temperature reading from the at least one electronic temperature sensor and to obtain a core body temperature therefrom, the readout controller including a temperature corrector (16) that increases the input temperature reading to account for a temperature difference between the input temperature reading and the core body temperature; **characterised in that:** the at least one electronic temperature sensor includes two conductive bodies (30, 31) separated by an insulating material (32), and the temperature corrector (16) comprises: a capacitance meter (37) configured to measure a mutual capacitance (C) of the two conductive bodies separated by the insulating material, the temperature difference being derived from the mutual capacitance and one or more temperature readings (T_1 , T_2) acquired by the at least one electronic temperature sensor.

2. The core body temperature measurement device as set forth in claim 1, wherein the at least one electronic temperature sensor (12) is operatively coupled with or near to a brain tunnel (BTT) between the eyes.

3. The core body temperature measurement device as set forth in claim 1, further comprising a variable heater which provides a perturbation of the temperature distribution from which the temperature corrector (16) derives the increase of the input temperature reading.

4. The core body temperature measurement device as set forth in claim 3, wherein the core body temperature measurement device further comprises:

a blood oxygen sensor (20) configured to acquire a blood oxygenation measurement, an optical source of the blood oxygen sensor (20) additionally being used to generate the variable heating.

5. The core body temperature measurement device as set forth in claim 1, 3 or 4, wherein the separation of the two conductive bodies (30, 31) is adjustable by actuators (34).

6. The core body temperature measurement device as set forth in claim 5, wherein one or both of the two conductive bodies (30, 31) comprises a protrusion (38) that decreases the separation distance between the two conductive bodies (30, 31).

7. A core body temperature measurement method comprising:

acquiring a plurality of temperature readings at and near a surface (STA, PAA, BTT) having a surface temperature approximating the core body temperature;
outputting a core body temperature based on the highest usable temperature;
correcting an input temperature or input temperatures from the acquired plurality of temperature readings for a temperature drop between the body core and said surface to generate the core body temperature, **characterised in that** the correcting comprises:
providing a temperature sensor including spaced-apart conductive bodies (30, 31) with one conductive body in

thermal contact at or near said surface (STA, PAA, BTT);
measuring a mutual capacitance of the spaced apart conductive bodies; and
estimating a heat flux between the conductive bodies based on the mutual capacitance.

- 5 **8.** The core body temperature measurement method as set forth in claim 7, wherein the surface having a surface temperature approximating the core body temperature is a brain tunnel (BTT) between the eyes.
9. The core body temperature measurement method as set forth in claim 7, wherein the correcting comprises:
- 10 variably heating the temperature sensor;
acquiring temperatures and a temperature derivative for the conductive bodies at a plurality of different heating levels; and
deriving the core body temperature from the acquired temperatures and temperature derivatives at the plurality of different heating levels.
- 15 **10.** The core body temperature measurement method as set forth in claim 9, wherein the variably heating comprises:
operating an optical source of a blood oxygen sensor (20) at different power levels to provide variable heating.
- 20 **11.** The core body temperature measurement method as set forth in claim 7, 9 or 10, further comprising the step of adjusting the separation of the two conductive bodies (30, 31) by actuators (34).

Patentansprüche

- 25 **1.** Vorrichtung zur Messung der Körperkerntemperatur, wobei die Vorrichtung Folgendes umfasst:
- mindestens einen elektronischen Temperatursensor (12, 12f, 12b, 132), der betriebsfähig an oder nahe einer Oberfläche (STA, PAA, BTT) mit einer Oberflächentemperatur, die sich der Körperkerntemperatur annähert, angebracht ist; und
- 30 eine Auslese-Steuereinheit (10, 48, 68, 90, 124), die konfiguriert ist, um einen Eingangstemperaturmesswert von dem mindestens einen elektronischen Temperatursensor zu erfassen und hiervon eine Körperkerntemperatur zu erlangen, wobei die Auslese-Steuereinheit eine Temperaturkorrektureinheit (16) umfasst, welche den Eingangstemperaturmesswert erhöht, um eine Temperaturdifferenz zwischen dem Eingangstemperaturmesswert und der Körperkerntemperatur zu berücksichtigen, **dadurch gekennzeichnet, dass:**
- 35 der mindestens eine elektronische Temperatursensor zwei leitende Körper (30, 31) umfasst, die durch ein isolierendes Material (32) voneinander getrennt sind, und die Temperaturkorrektureinheit (16) Folgendes umfasst:
- 40 einen Kapazitätsmesser (37), der konfiguriert ist, um die Gegenkapazität (C) der beiden leitenden, durch das isolierende Material getrennten Körper zu messen, wobei die Temperaturdifferenz von der Gegenkapazität und einem oder mehreren durch den mindestens einen elektronischen Temperatursensor erfassten Temperaturmesswert(en) (T_1 , T_2) abgeleitet wird.
- 45 **2.** Vorrichtung zur Messung der Körperkerntemperatur nach Anspruch 1, wobei der mindestens eine elektronische Temperatursensor (12) betriebsfähig an oder nahe einem Gehirntemperaturtunnel (BTT) zwischen den Augen angebracht ist.
- 50 **3.** Vorrichtung zur Messung der Körperkerntemperatur nach Anspruch 1, weiterhin mit einer variablen Heizeinheit, welche für eine Störung der Temperaturverteilung sorgt, aus der die Temperaturkorrektureinheit (16) die Zunahme des Eingangstemperaturmesswertes ableitet.
- 55 **4.** Vorrichtung zur Messung der Körperkerntemperatur nach Anspruch 3, wobei die Vorrichtung zur Messung der Körperkerntemperatur weiterhin Folgendes umfasst:
- einen Blutsauerstoffsensoren (20), der konfiguriert ist, um einen Blutsauerstoffmesswert zu erfassen, wobei eine optische Quelle des Blutsauerstoffsensors (20) zusätzlich verwendet wird, um die variable Erwärmung zu erzeugen.

EP 2 120 681 B1

5. Vorrichtung zur Messung der Körperkerntemperatur nach Anspruch 1, 3 oder 4, wobei die Trennung der beiden leitenden Körper (30, 31) durch Stellglieder (34) einstellbar ist.
6. Vorrichtung zur Messung der Körperkerntemperatur nach Anspruch 5, wobei einer oder beide der beiden leitenden Körper (30, 31) einen Vorsprung (38) umfasst, der den Trennungsabstand zwischen den beiden leitenden Körpern (30, 31) verringert.
7. Verfahren zur Messung der Körperkerntemperatur, das Folgendes umfasst:
- 10 Erfassen einer Vielzahl von Temperaturmesswerten an und nahe einer Oberfläche (STA, PAA, BTT) mit einer Oberflächentemperatur, die sich der Körperkerntemperatur annähert;
Ausgeben einer Körperkerntemperatur basierend auf der höchsten verwendbaren Temperatur;
Korrigieren einer Eingangstemperatur oder von Eingangstemperaturen aus der erfassten Vielzahl von Temperaturmesswerten in Bezug auf einen Temperaturabfall zwischen dem Körperkern und der genannten Oberfläche, um die Körperkerntemperatur zu erzeugen, **dadurch gekennzeichnet, dass** das Korrigieren Folgendes umfasst:
- 15 Schaffen eines Temperatursensors mit in einem Abstand voneinander angeordneten leitenden Körpern (30, 31), wobei sich ein leitender Körper in thermischem Kontakt an oder nahe der genannten Oberfläche (STA, PAA, BTT) befindet;
- 20 Messen einer Gegenkapazität der in einem Abstand voneinander angeordneten leitenden Körper; und
Schätzen eines Wärmeflusses zwischen den leitenden Körpern basierend auf der Gegenkapazität.
8. Verfahren zur Messung der Körperkerntemperatur nach Anspruch 7, wobei die Oberfläche mit einer sich der Körperkerntemperatur annähernden Oberflächentemperatur ein Gehirntemperaturtunnel (BTT) zwischen den Augen ist.
- 25 9. Verfahren zur Messung der Körperkerntemperatur nach Anspruch 7, wobei das Korrigieren Folgendes umfasst:
- variables Erwärmen des Temperatursensors;
Erfassen von Temperaturen und einer Temperaturableitung für die leitenden Körper bei einer Vielzahl von unterschiedlichen Erwärmungsstufen; und
30 Ableiten der Körperkerntemperatur von den erfassten Temperaturen und Temperaturableitungen bei der Vielzahl von unterschiedlichen Erwärmungsstufen.
10. Verfahren zur Messung der Körperkerntemperatur nach Anspruch 9, wobei das variable Erwärmen Folgendes umfasst:
- 35 Betreiben einer optischen Quelle eines Blutsauerstoffsensors (20) auf unterschiedlichen Leistungsstufen zum Schaffen einer variablen Erwärmung.
- 40 11. Verfahren zur Messung der Körperkerntemperatur nach Anspruch 7, 9 oder 10, weiterhin mit dem Schritt des Einstellens der Trennung der beiden leitenden Körper (30, 31) durch Stellglieder (34).

Revendications

- 45 1. Dispositif de mesure de température corporelle interne comprenant :
- au moins un détecteur de température électronique (12, 12f, 12b, 132) couplé fonctionnellement à ou près d'une surface (STA, PAA, BTT) ayant une température de surface s'approchant de la température corporelle interne ; et
- 50 un contrôleur de lecture (10, 48, 68, 90, 124) configuré pour acquérir une lecture de température d'entrée de l'au moins un détecteur de température électronique et pour obtenir de celui-ci une température corporelle interne, le contrôleur de lecture comportant un correcteur de température (16) qui augmente la lecture de température d'entrée pour tenir compte d'une différence de température entre la lecture de température d'entrée et la température corporelle interne ; **caractérisé en ce que** :
- 55 l'au moins un détecteur de température électronique comporte deux corps conducteurs (30, 31) séparés par un matériau isolant (32), et le correcteur de température (16) comprend :
- un dispositif de mesure de capacité (37) configuré pour mesurer une capacité mutuelle (C) des deux corps

EP 2 120 681 B1

conducteurs séparés par le matériau isolant, la différence de température étant dérivée de la capacité mutuelle et d'une ou plusieurs lectures de température (T_1 , T_2) acquises par l'au moins un capteur de température électronique.

- 5 2. Dispositif de mesure de température corporelle interne selon la revendication 1, dans lequel l'au moins un détecteur de température électronique (12) est couplé fonctionnellement à ou près d'un tunnel de cerveau (BTT) entre les yeux.
3. Dispositif de mesure de température corporelle interne selon la revendication 1, comprenant en outre un réchauffeur variable qui fournit une perturbation de la répartition de température de laquelle le correcteur de température (16) dérive l'augmentation de la lecture de température d'entrée.
- 10 4. Dispositif de mesure de température corporelle interne selon la revendication 3, dans lequel le dispositif de mesure de température corporelle interne comprend en outre :
- 15 un détecteur d'oxygène dans le sang (20) configuré pour acquérir une mesure d'oxygénation du sang, une source optique du détecteur d'oxygène dans le sang (20) étant en outre utilisée pour générer le chauffage variable.
- 20 5. Dispositif de mesure de température corporelle interne selon la revendication 1, 3 ou 4, dans lequel la séparation des deux corps conducteurs (30, 31) est réglable par des actionneurs (34).
6. Dispositif de mesure de température corporelle interne selon la revendication 5, dans lequel un ou deux des deux corps conducteurs (30, 31) comprennent une protubérance (38) qui réduit la distance de séparation entre les deux corps conducteurs (30,31).
- 25 7. Procédé de mesure de température corporelle interne comprenant les opérations consistant à :
- acquérir une pluralité de lectures de température à et près d'une surface (STA, PAA, BTT) ayant une température de surface s'approchant de la température corporelle interne ;
- 30 émettre une température corporelle interne sur la base de la température utilisable la plus élevée ;
- corriger une température d'entrée ou des températures d'entrée parmi la pluralité de lectures de température acquises pour une baisse de température entre l'intérieur du corps et ladite surface pour générer la température corporelle interne, **caractérisé en ce que** la correction comprend les opérations consistant à :
- 35 fournir un détecteur de température comprenant des corps conducteurs espacés l'un de l'autre (30, 31) avec un corps conducteur en contact thermique à ou près de ladite surface (STA, PAA, BTT) ;
- mesurer une capacité mutuelle des corps conducteurs espacés l'un de l'autre ; et
- estimer un flux de chaleur entre les corps conducteurs sur la base de la capacité mutuelle.
- 40 8. Procédé de mesure de température corporelle interne selon la revendication 7, dans lequel la surface ayant une température de surface s'approchant de la température corporelle interne est un tunnel de cerveau (BTT) entre les yeux.
9. Procédé de mesure de température corporelle interne selon la revendication 7, dans lequel la correction comprend les opérations consistant à :
- 45 chauffer variablement le détecteur de température ;
- acquérir des températures et une dérivée de température pour les corps conducteurs à une pluralité de niveaux de chauffage différents ; et
- dériver la température corporelle interne des températures et des dérivés de températures acquises à la pluralité
- 50 des niveaux de chauffage différents.
10. Procédé de mesure de température corporelle interne selon la revendication 9, dans lequel le chauffage variable comprend les opérations consistant à :
- 55 faire fonctionner une source optique d'un détecteur d'oxygène dans le sang (20) à différents niveaux de puissance pour fournir un chauffage variable.
11. Procédé de mesure de température corporelle interne selon la revendication 7, 9 ou 10, comprenant en outre

EP 2 120 681 B1

l'opération consistant à régler la séparation des deux corps conducteurs (30, 31) par les actionneurs (34).

5

10

15

20

25

30

35

40

45

50

55

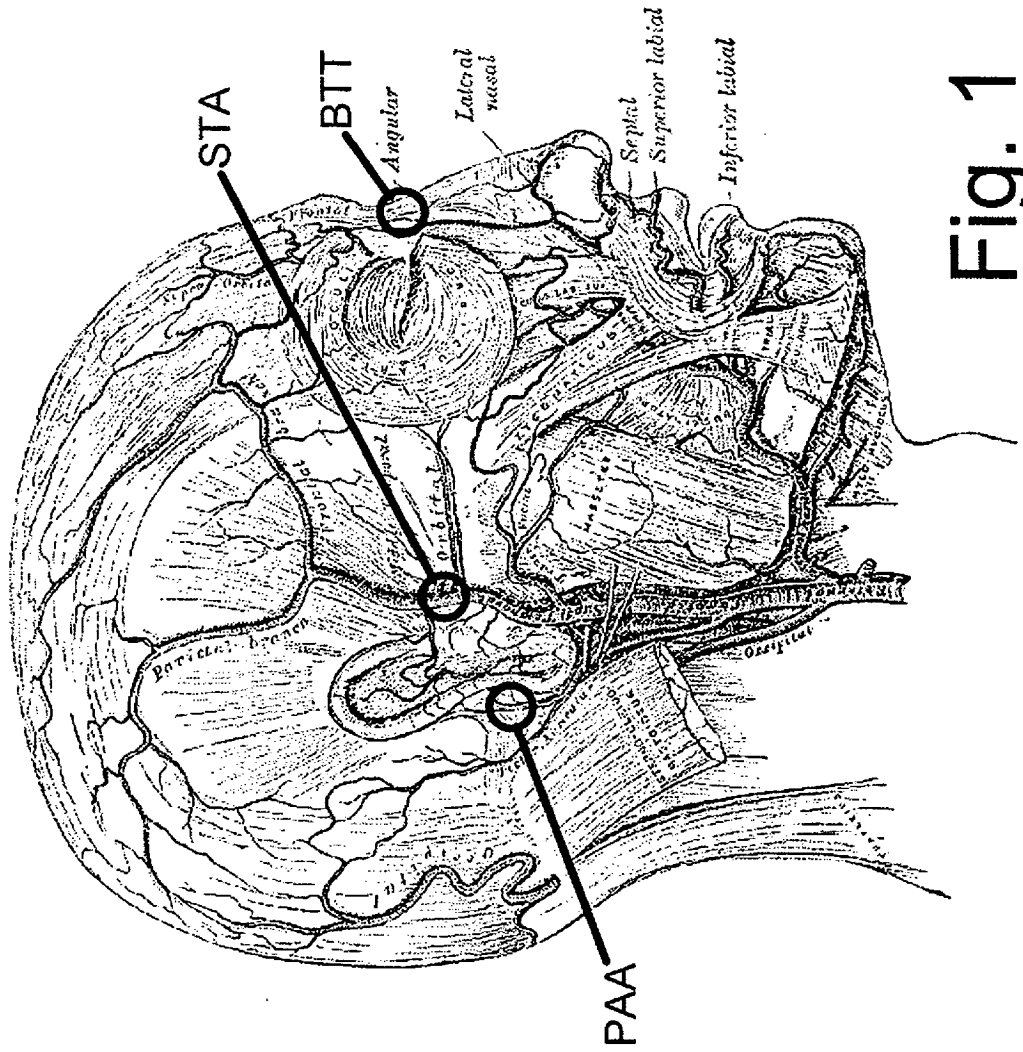

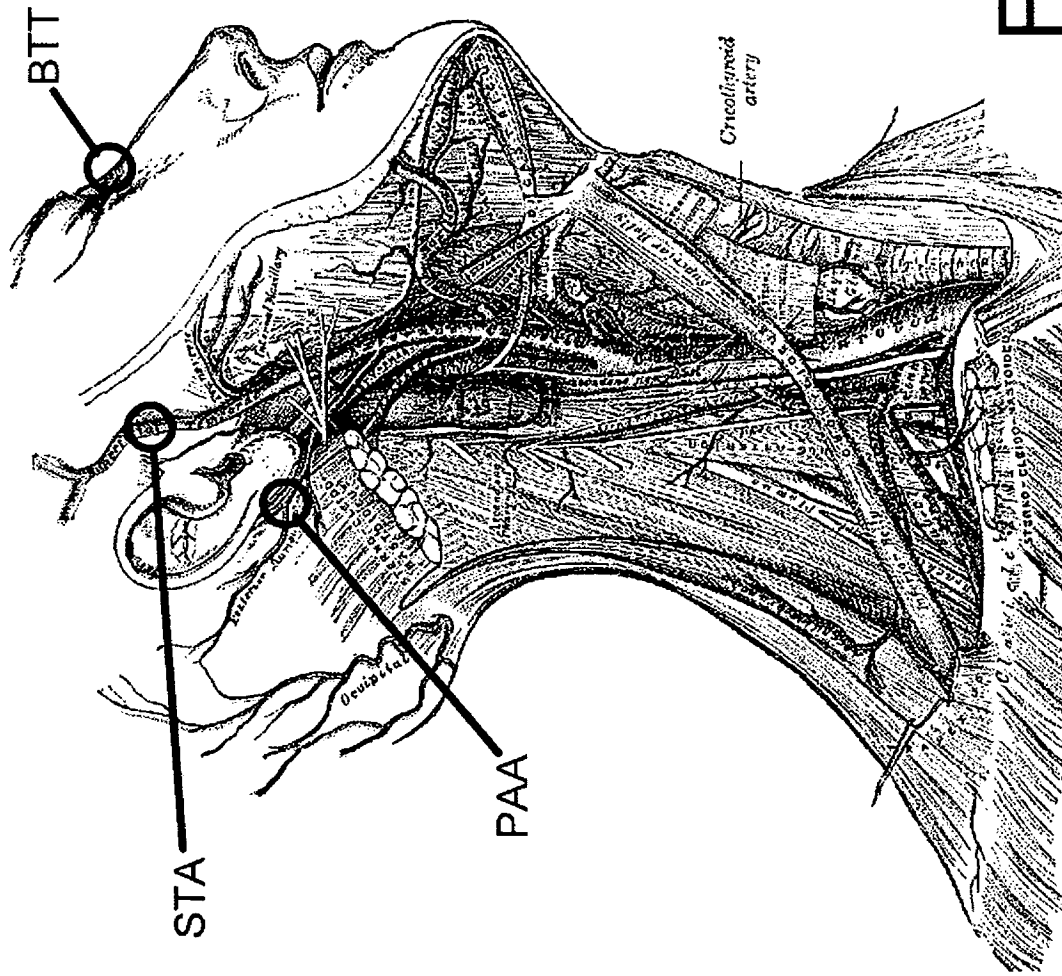

Fig. 2

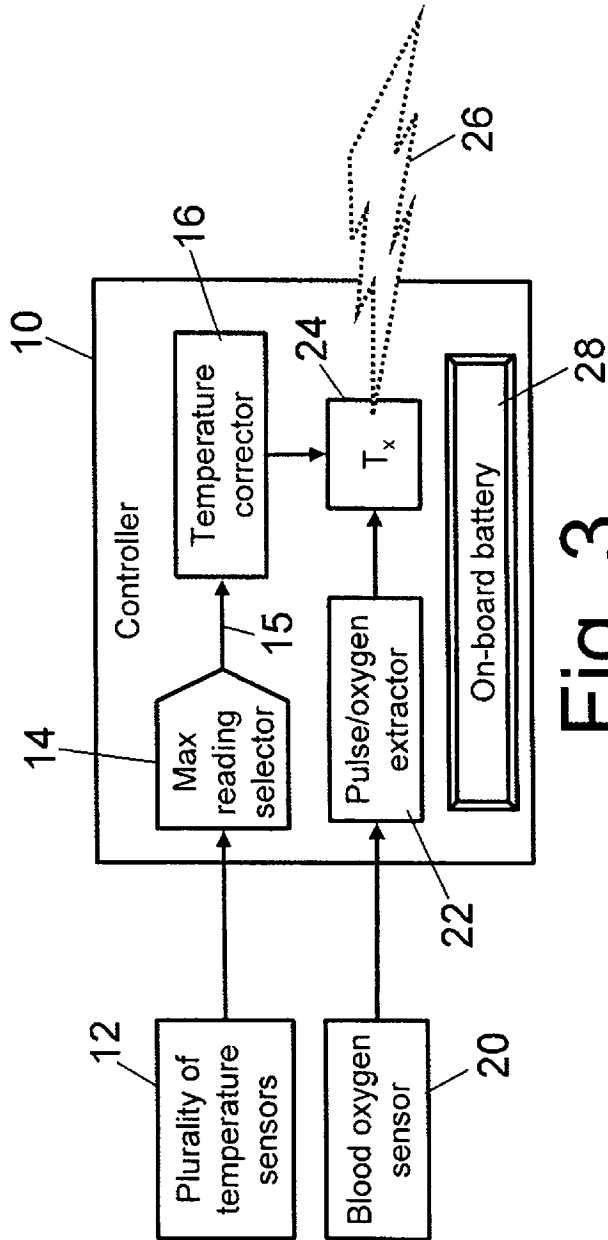

Fig. 3

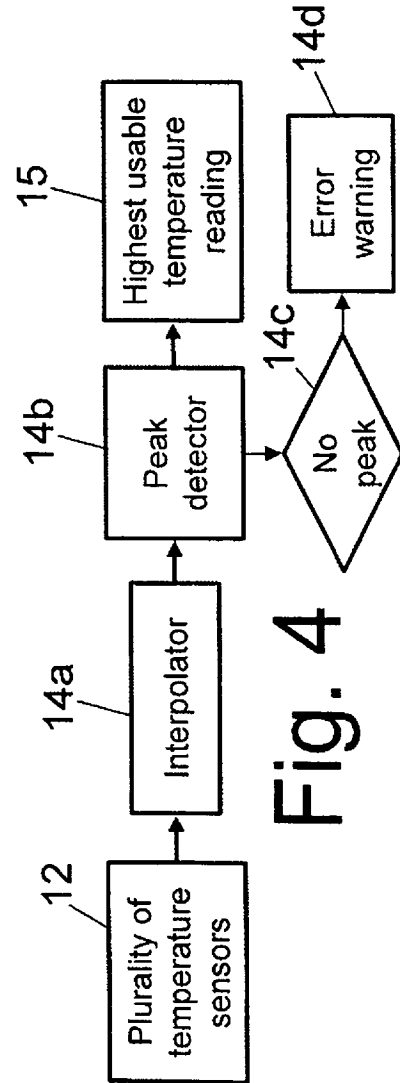

Fig. 4

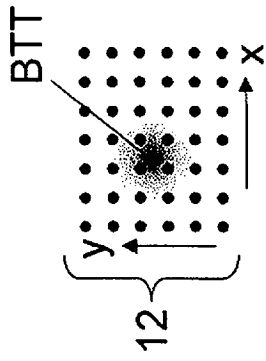

Fig. 5

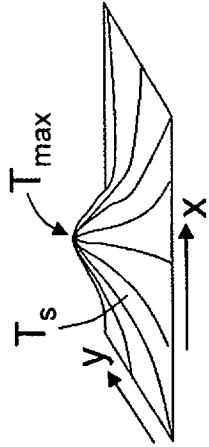

Fig. 6

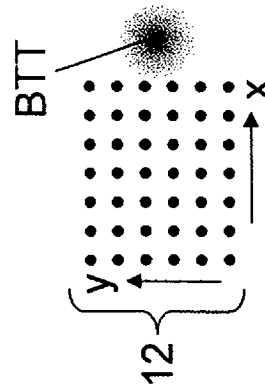

Fig. 7

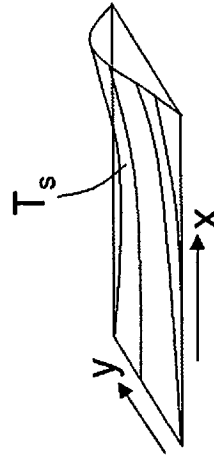

Fig. 8

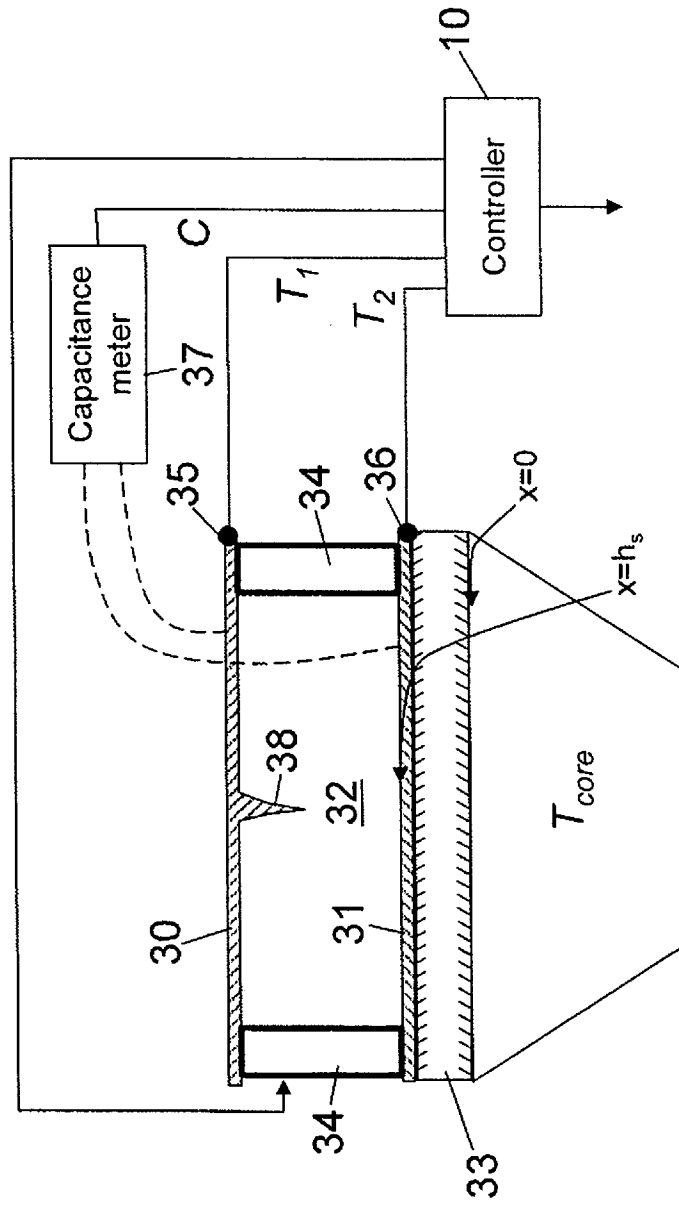

Fig. 9

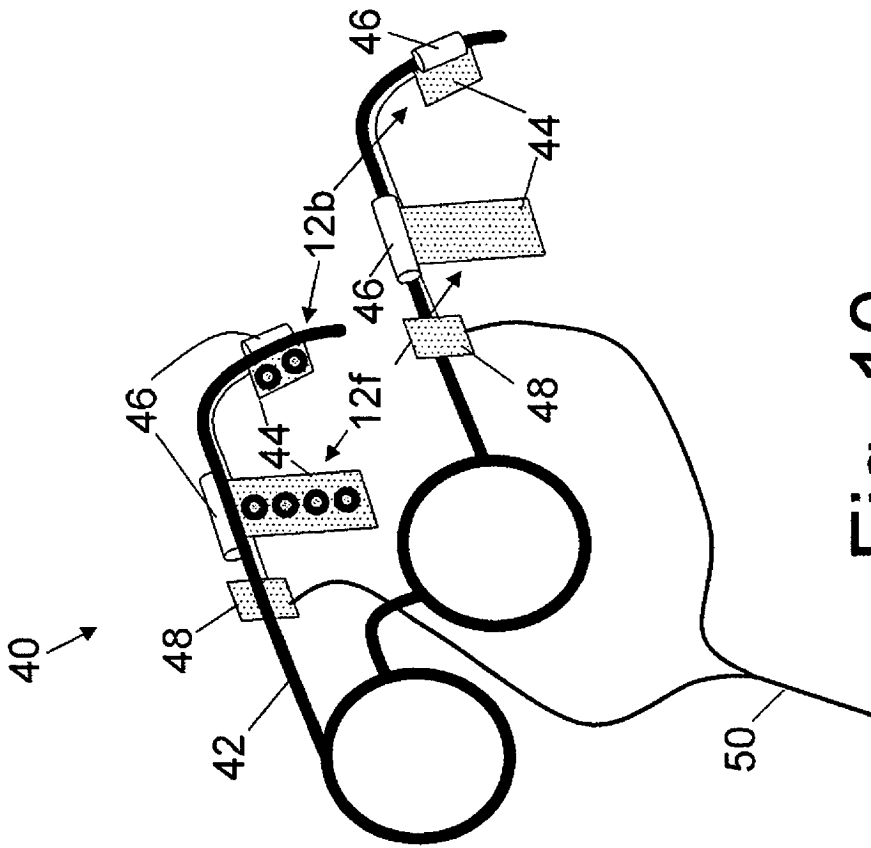

Fig. 10

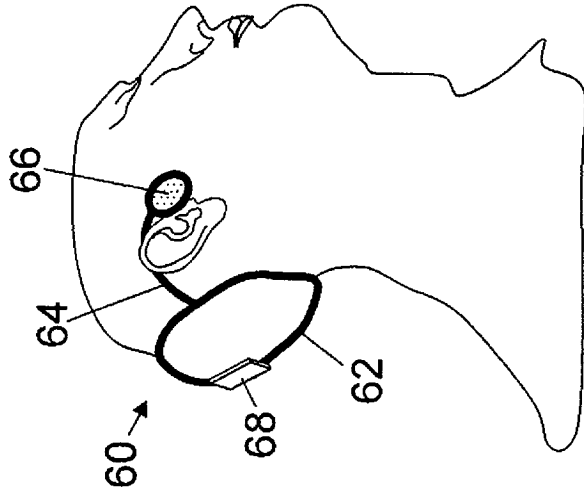

Fig. 11

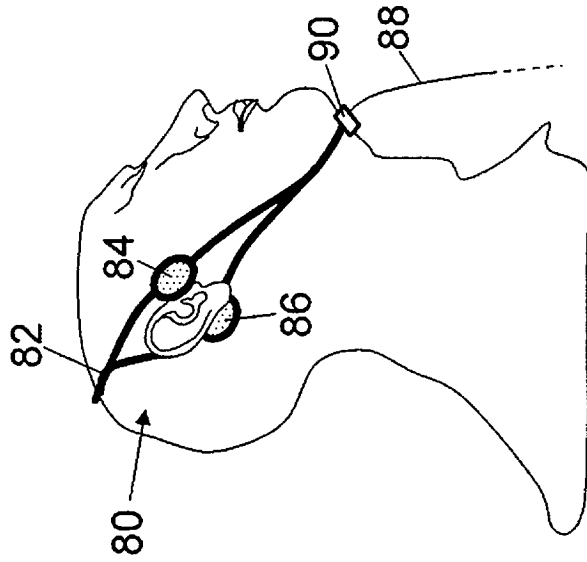

Fig. 12

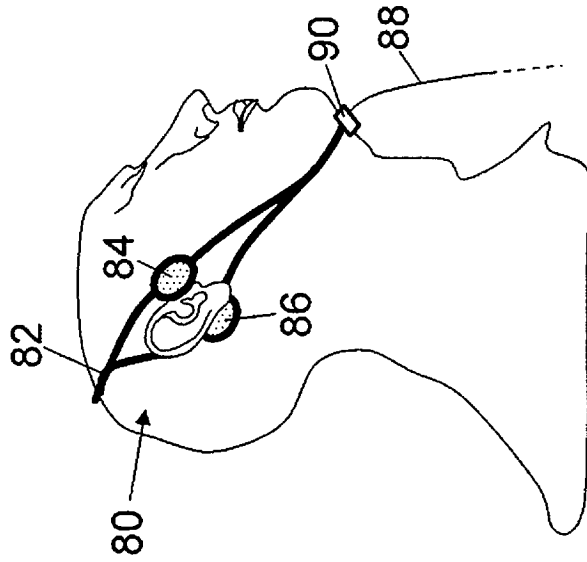

Fig. 13

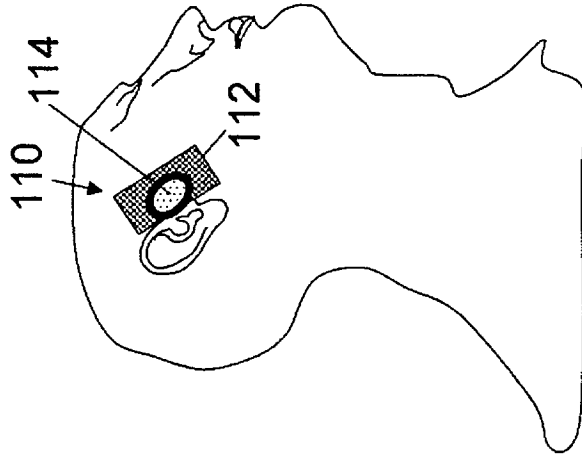

Fig. 14

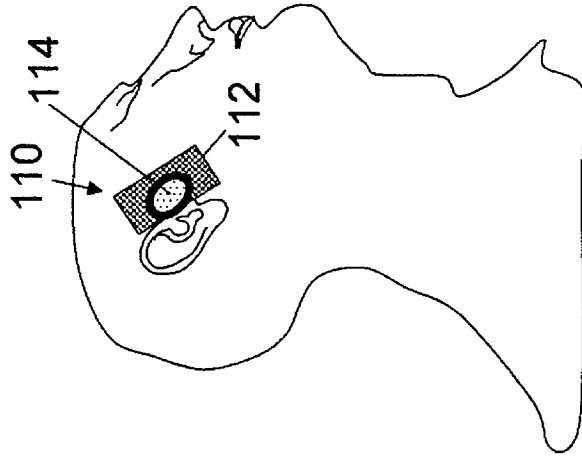

Fig. 15

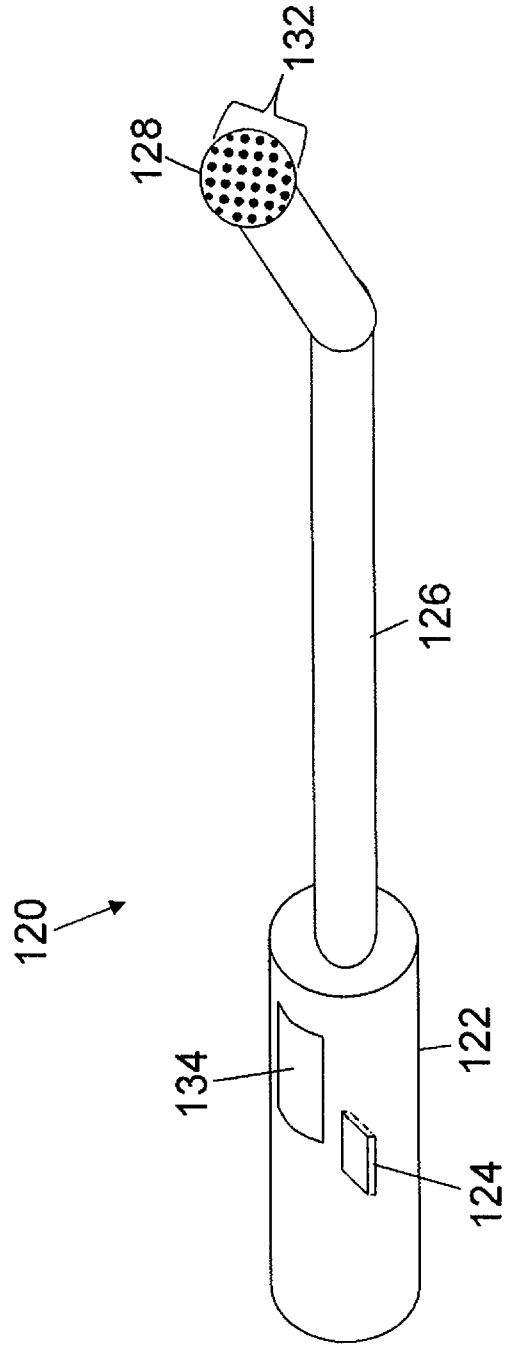

Fig. 16

REFERENCES CITED IN THE DESCRIPTION

This list of references cited by the applicant is for the reader's convenience only. It does not form part of the European patent document. Even though great care has been taken in compiling the references, errors or omissions cannot be excluded and the EPO disclaims all liability in this regard.

Patent documents cited in the description

- US 20040059212 A [0008] [0021] [0051]
- CA 2538940 A1 [0009]
- US 20060189884 A [0010]
- WO 2004001373 A [0011]
- US 3933045 A, Fox [0036]
- US 5816706 A, Heikkilä [0036]
- US 6886978 B, Tokita [0036] [0043]

专利名称(译)	测量核心体温的方法和装置		
公开(公告)号	EP2120681B1	公开(公告)日	2011-07-13
申请号	EP2008710063	申请日	2008-02-15
[标]申请(专利权)人(译)	皇家飞利浦电子股份有限公司		
申请(专利权)人(译)	皇家飞利浦电子N.V.		
当前申请(专利权)人(译)	皇家飞利浦电子N.V.		
[标]发明人	PADIY ALEXANDER V		
发明人	PADIY, ALEXANDER, V.		
IPC分类号	A61B5/00 G01K13/00		
CPC分类号	G01K13/002 A61B5/0002 A61B5/015 A61B5/145 A61B5/4064 A61B5/6814 A61B5/6815 A61B5/6833 A61B5/6838 A61B2562/0271 G01K1/026 G01K1/16 G01K7/42		
优先权	60/894916 2007-03-15 US		
其他公开文献	EP2120681A1		
外部链接	Espacenet		

摘要(译)

核心体温测量装置包括多个电子温度传感器 (12, 12f, 12b, 132), 其与表面温度接近核心体温的表面 (STA, PAA, BTT) 可操作地耦合或附近, 以及读出控制器 (10, 48, 68, 90, 124) 包括最高温度读数选择器 (14)。读出控制器被配置为使用多个温度传感器获取温度读数, 并基于由最大温度读数选择器确定的所获取的温度读数的最高可用温度读数输出核心体温。一种核心体温测量方法, 包括: 获取表面温度接近核心体温的表面 (STA, PAA, BTT) 及其附近的多个温度读数; 从获得的温度读数产生最高可用温度读数; 并根据最高可用温度输出核心体温。

