

(19) World Intellectual Property Organization  
International Bureau



(43) International Publication Date  
16 August 2001 (16.08.2001)

PCT

(10) International Publication Number  
**WO 01/58349 A1**

- (51) International Patent Classification<sup>7</sup>: **A61B 5/00**
- (21) International Application Number: PCT/US01/04343
- (22) International Filing Date: 12 February 2001 (12.02.2001)
- (25) Filing Language: English
- (26) Publication Language: English
- (30) Priority Data:  
60/182,018 11 February 2000 (11.02.2000) US
- (71) Applicant (for all designated States except US): **U.S. ARMY INSTITUTE OF SURGICAL RESEARCH** [US/US]; 3400 Rawley E. Chambers, Bldg. 3611, Fort Sam Houston, TX 78234-6315 (US).
- (72) Inventors; and
- (75) Inventors/Applicants (for US only): **WALKER, Steven, C.** [US/US]; 709a Ridgeside Drive, Baldwin, MO 63021 (US). **ALEXANDER, John, G.** [US/US]; 169 Liberty Crossing, O'Fallon, IL 62269 (US). **SHEPHERD, John, M.** [US/US]; 9210 Marymount Park, San Antonio, TX 78217 (US).
- (74) Agent: **ARWINE, Elizabeth**; Office of the Staff Judge Advocate, U.S. Army Medical Research and Material Command, Attn : MCMR - JA, 504 Scott Str, Fort Detrick, MD 21702-5102 (US).
- (81) Designated States (national): AE, AG, AL, AM, AT, AU, AZ, BA, BB, BG, BR, BY, BZ, CA, CH, CN, CR, CU, CZ, DE, DK, DM, DZ, EE, ES, FI, GB, GD, GE, GH, GM, HR, HU, ID, IL, IN, IS, JP, KE, KG, KP, KR, KZ, LC, LK, LR, LS, LT, LU, LV, MA, MD, MG, MK, MN, MW, MX, MZ, NO, NZ, PL, PT, RO, RU, SD, SE, SG, SI, SK, SL, TJ, TM, TR, TT, TZ, UA, UG, US, UZ, VN, YU, ZA, ZW.
- (84) Designated States (regional): ARIPO patent (GH, GM, KE, LS, MW, MZ, SD, SL, SZ, TZ, UG, ZW), Eurasian patent (AM, AZ, BY, KG, KZ, MD, RU, TJ, TM), European patent (AT, BE, CH, CY, DE, DK, ES, FI, FR, GB, GR, IE, IT, LU, MC, NL, PT, SE, TR), OAPI patent (BF, BJ, CF, CG, CI, CM, GA, GN, GW, ML, MR, NE, SN, TD, TG).
- Published:**  
— with international search report  
— before the expiration of the time limit for amending the claims and to be republished in the event of receipt of amendments

For two-letter codes and other abbreviations, refer to the "Guidance Notes on Codes and Abbreviations" appearing at the beginning of each regular issue of the PCT Gazette.

(54) Title: PACIFIER PULSE OXIMETER SENSOR

WO 01/58349 A1

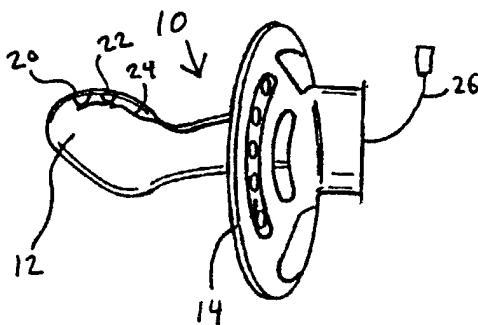

(57) Abstract: A pacifier pulse oximeter sensor includes pulse oximeter sensor elements (20, 22) located within the nipple of a pacifier (10). The pulse oximeter sensor elements (20, 22) may be completely within the nipple (12) material, embedded within the nipple material, nested within the nipple material, or adjacent to the nipple material while not being exposed to the outside environment. The pulse oximeter sensor elements (20, 22) include a light source (20) and a light detector (22). The pulse oximeter sensor elements (20, 22) communicate with an oximeter through wiring (24), an electrical connector, and/or wirelessly. An alternative embodiment adds oximeter processing capabilities to the pacifier pulse oximeter sensor.

## PACIFIER PULSE OXIMETER SENSOR

### I. FIELD OF THE INVENTION

This invention is directed to an apparatus and a method for measuring blood oxygenation from locations within the oral cavity of a subject, for example, a small child or a small/newborn animal. More particularly, the invention relates to using pulse oximeter sensors to perform reflective pulse oximetry within the oral cavity of a subject.

### II. BACKGROUND OF THE INVENTION

With a few exceptions, tradition and technology have favored transillumination pulse oximetry in the operating theater. The principle of operation of the pulse oximeter is fairly simple but is arguably the most important development in anesthesia monitoring in the twentieth century. Two wavelengths of light (usually 660 nm and 940 nm) are used to spectrophotometrically determine the ratio of oxidized to reduced hemoglobin noninvasively as well as to determine the pulsatility of blood plethysmographically.

However, reflectance oximetry rather than transillumination oximetry was the earliest investigative form of the technique for taking oximeter readings. Transillumination pulse oximetry, without question, is the most effective form when oximetry is obtained through skin. However, when skin is not interposed as a barrier to capillary bed access, reflectance pulse oximetry easily can be achieved with very accurate results. Indeed, it is used commonly and effectively among intrapartum and neonatal patients whose capillary beds are easily accessed through their skin. The technique has also been applied to adult and pediatric burn patients by placing the reflectance sensor in wounds or over hyperemic sites such as healed partial thickness burns. The effect is achieved by the backscattering of incident bispectral light that traverses and, on reflection from nonabsorptive collagenous tissues, retraverses formed elements in the blood back to the oximeter elements. Rather than superseding

transillumination pulse oximetry, this technique broadens the scope of possible monitoring sites, adding to the clinician's armamentarium.

Presently, the most common application of this in a medical setting is via transillumination through the capillary bed of a peripheral digit. However, young patients such as babies are apt to remove or reject foreign objects such as finger oximeters or inserted tubes upon realizing their placement when recovering from anesthesia or awaking from sleep. Sick children, in particular, are more likely to be restless and easily agitated and thus will resist any attempts to have medical readings taken like temperature or oximeter readings. Additionally, it is not unusual for multitrauma and thermally injured patients to either have severe peripheral vasoconstriction or to have severely damaged (or missing due to amputation) peripheral vascular beds.

There are other often overlooked capillary beds readily accessible in most adult burn patients and young children that are as amenable to reflectance oximetry similar to the forehead of the premature infant. The buccal surface, posterior soft palate, hard palate, lingual surfaces, and gums of a burned patient and/or child are seldom compromised no matter how severe the burn, and the capillary beds are very close to the surface in those areas. Transillumination pulse oximetry of the tongue and cheek has been documented as a viable method of monitoring, but not everyone has the equipment available to place a transilluminating pulse oximeter on the tongue or cheek.

Recent studies indicate that oral pulse oximetry is a superior modality when compared to peripheral transillumination pulse oximetry. A variety of studies have shown that oral pulse oximeters are more reliably and rapidly responsive than peripheral pulse oximeters. However, these studies use oral transillumination pulse oximetry, held in place via complex devices or pieces of improvised malleable metal.

Oral secretions, equipment failure, and placement difficulty often render these techniques ineffective.

Prior pulse oximeter sensors inserted through the mouth are usable only when the patient is under general anesthesia. These pulse oximeter sensors are inserted to reach the larynx area, for example, U.S. Patent No. 5,282,464 to Brain et al. Another known method uses transillumination pulse oximetry of the posterior tongue, but this method possibly may not be used with a patient, who is awake, for example. U.S. Patent No. 5,205,281 to Buchanan. Also, the posterior tongue is not the most accessible body part to take oximetry measurements.

Notwithstanding the usefulness of the above-described devices, and the above-identified recognized viability of transilluminating pulse oximetry, a need exists for a more convenient method for obtaining oximeter readings from a subject.

### **III. SUMMARY OF THE INVENTION**

The invention while addressing the problems of the prior art obtains advantages that were not achievable with the prior art apparatuses and methods.

An object of this invention is to provide an effective method for taking pulse oximetry measurements from oral capillary beds.

Another object of the invention is the use of reflectance pulse oximetry via the oral cavity for a variety of surgical, anesthetic, or critical care procedures or situations to include patients that are awake, undergoing general anesthesia, or recovering from general anesthesia.

Another object of the invention is to allow for lingual placement of a pulse oximeter sensor for reflectance readings to provide efficient and clinically accurate pulse oximetry measurements.

Another object of the invention is to allow for buccal placement of a pulse oximeter sensor for reflectance readings to provide efficient and clinically accurate pulse oximetry measurements.

Yet another object of the invention is to monitor oxygen levels in newborns and young children who are difficult to monitor because of their natural restlessness and young age.

Still another object of the invention is to monitor oxygen levels in severely burned ICU patients who are difficult to monitor.

An advantage of the invention is an improvement in the quality of care resulting from using a straightforward method with easily used devices to take internal oximetry measurements and readings.

Another advantage of the invention is that EMS crews and personnel will be able to use this invention easily in the field during, for example, emergency situations.

Another advantage of the invention is improved pulse oximetry readings.

Another advantage of the invention is reflectance pulse oximetry requires less power to function and thus less heat is produced than transillumination pulse oximetry. The decrease in produced heat lowers the risk the subject will be burned.

Yet another advantage of the invention is that ambient light will not degrade the oximeter readings because the invention is within the mouth of a subject.

The apparatus and the method accomplish the above objectives and achieve the advantages. The apparatus and the method are easily adapted to a wide variety of situations.

Furthermore, intraoral buccal, palatal, or lingual placement of a pulse oximeter probe in a configuration relying upon reflected light will provide pulse oximetry measurements comparable to those obtained by peripheral pulse oximetry. Test protocols suggest that buccal and palatal reflectance pulse oximetry provides a simple,

accurate means of monitoring arterial oxygen saturation in the severely burned patient where oximetric monitoring presents a challenge.

Furthermore, the apparatus to perform this method is extremely useful in cases where it is difficult at best or not even possible to attach prior art pulse oximeter sensors with clips or straps to the patient. The types of patients that this apparatus would be useful with are critically ill or injured patients including newborns, babies, young children, young animals, and burn or trauma patients without alternative sites and maxillofacial injuries.

Given the following enabling description of the drawings, the apparatus and the method should become evident to a person of ordinary skill in the art.

#### **IV. DESCRIPTION OF THE DRAWINGS**

The use of cross-hatching within these drawings should not be interpreted as a limitation on the potential materials used for construction. Like reference numerals in the figures represent and refer to the same element or function.

Figure 1 depicts a side view of the preferred embodiment of the invention.

Figure 2 illustrates a side cross-section of a nipple of the preferred embodiment of the invention.

Figures 3-10 depict side cross-sections of a nipple to illustrate various alternative placements and arrangements of pulse oximeter elements according to the invention.

Figures 11-16 illustrate top views of various alternative placements and arrangements of the pulse oximeter elements according to the invention.

Figures 17 and 18 depict the invention in use in a subject.

Figures 19 and 20 illustrate cross-sections of examples of attaching the nipple to the shield for the preferred embodiment of the invention.

Figures 21(a)-(b) depict an example of a shield structure for use in the preferred embodiment of the invention.

Figure 22 illustrates a top view of an alternative embodiment of the invention.

Figure 23 depicts a top cross-section of another alternative embodiment of the invention.

Figure 24 illustrates a rear view of the alternative embodiment of the invention illustrated in Figure 23.

Figure 25 depicts a block diagram for an alternative embodiment of the invention illustrated in Figures 23 and 24.

Figure 26 illustrates a top view of another alternative embodiment of the invention.

Figure 27 depicts a flowchart illustrating the steps for performing the preferred embodiment.

## **V. DETAILED DESCRIPTION OF THE INVENTION**

Figures 1-18 illustrate a preferred embodiment and alternative component arrangements of the pacifier oximeter sensor assembly. The assembly preferably includes a pacifier 10, pulse oximeter sensor elements 20, 22, and wiring 24.

The pacifier 10 preferably includes a nipple (or baglet) 12 and a shield (or guard) 14. The nipple 12 may be a variety of shapes in addition to those shown in Figures 1-18 that will allow the subject to apply a suction force to the nipple 12. Exemplary shapes for the nipple 12 include orthodontic, bottle nipple, spherical, and thumb shaped. The nipple 12 preferably is a flexible material typically used to make pacifiers and baby bottle nipples such as polypropylene, polyvinyl chloride, silicones, epoxies, polyester, thermoplastics, rubber, or similar flexible material. Preferably, the material used to make the nipple 12 will be at least partially translucent to allow light to pass through in the area of the pulse oximeter sensor elements 20, 22. Preferably, the

nipple 12 will have an inner cavity 124 formed as a void in the nipple material 122. However, the nipple 12 may be solid or filled with a flexible material to increase the protection of the pulse oximeter sensor elements 20, 22 and wiring 24.

The pulse oximeter sensor elements 20, 22 preferably are within the material 122 making up the nipple 12 to reduce the impact of the material 122 on the transmission of light through the material 122. However, the pulse oximeter sensor elements 20, 22 may be nested within the nipple material 122 as shown, for example, in Figure 4 or the pulse oximeter sensor elements 20, 22 may abut the nipple material 122 on the inner cavity surface as shown, for example, in Figure 3. The pulse oximeter sensor elements 20, 22 preferably will be placed in a position to transmit light and receive backscattered light from a capillary bed within the oral cavity of the subject as illustrated, for example, in Figures 17 and 18. The preferred locations are along the top of the nipple 12 (Figures 2-4), at the tip of the nipple 12 (Figure 5), and along the bottom of the nipple 12 (Figure 6). Also, the pulse oximeter elements 20, 22 may be located in and/or along the nipple shank 126 as illustrated, for example, in Figures 7-10.

Preferably, the pulse oximeter sensor elements include a light source 20 and a light detector 22. The placement and location of the light source 20 and the light detector 22 depicted in Figures 1-18 may be switched with respect to each other. Furthermore, the light source 20 and the light detector 22 may be in a variety of exemplary spatial locations relative to each other as shown, for example, in Figures 11-16. Although Figures 11-16 illustrated the pulse oximeter sensor elements 20, 22 on the top of the nipple 12, these elements may have similar spatial locations on other portions of the nipple 12 such as the tip, bottom, and along the shank 126.

The light source 20 preferably emits at least two frequencies of light in the red region, for example with a wavelength of 660 nm, and in the infrared region, for

example with a wavelength of 940 nm, preferably in response to a signal from a spectrophotometer, other similar oximeter monitoring devices or multiparameter patient monitoring systems that provide oximetry readings. The light source 20 preferably is one or more of the following: two light emitters such as light emitting diodes (LED), a bispectral emitter, a dual spectral emitter, a photoemitter, or a semiconductor die. However, any light source that facilitates reflectance pulse oximetry may be employed. Typically, the two emitter arrangement will include a red LED around or at 660 nm and a near-infrared LED emitting in the range of 890 to 950 nm and more particularly at about 940 nm. The light source 20 may emit light having a bandwidth, for example, in the range of 20 to 50 nm.

Preferably, the light detector 22 detects light emitted by the light source 20. Signals representing the detected light are transmitted by the light detector 22 to a spectrophotometer, an oximeter monitoring device or a multiparameter patient monitoring system that provides oximetry readings by discriminating between the relative intensity of these emissions and provides an index as to the degree of oxygen saturation of hemoglobin in blood. Preferably, the light detector 22 may be one of the following: a photoelectric receiver, a photodetector, or a semiconductor die.

The wiring 24 preferably includes conductive lines and contact electrodes. The wiring 24 preferably is embedded within the nipple material 122, or passes through the nipple cavity 124, or some combination of these two. An external cord 26 preferably is insulated and connects to the wiring 24 at a proximal end of the pacifier 126 so that the external cord 26 is outside of the oral cavity of the subject. The external cord 26 preferably includes a standard plug design to interface with a pulse oximetry spectrophotometer, a pulse monitor such as a plethysmograph, or other external device. Alternatively, the external cord 26 may be a jack to connect to a reusable

cable such as the cable sold with the Nellcor® OxiCliq® systems (Mallinckrodt, Inc., St. Louis, Missouri, U.S.A.).

The nipple 12 preferably is attached or mounted to the shield 14. An example of one type of mounting is integrally forming the nipple 12 with the shield 14, for example by mechanically coupling the nipple 12 to the shield 14. Another mounting arrangement, as illustrated in Figure 19, is to have the nipple 12 include a shank 126' with two integral spaced collars 1262, 1264 to form a channel to receive the shield 14. Preferably, the shield 14 is at or near the proximal end of the shank 126'. Preferably to prevent the shield 14 from being pulled off the shank 126', a handle 16 is looped through the shank 126' as illustrated in Figure 19.

Another example of attaching the nipple 12 to the shield 14 is illustrated in Figure 20. The shield 14 includes an opening for the nipple shank 126 to pass through preferably such that a rim or section of rolled up material 1266 is located on the proximal side of the shield 14. A plug 18 is inserted into the shield opening 142 to hold the nipple shank 126 in place with respect to the shield 14. More preferably, the plug 18 will include a securing mechanism that is compressed as it travels through the shield opening 142 and then expands on the distal side of the shield 14 to secure the plug 18 in place and hold the nipple 12 securely to the shield 14.

The shield 14 preferably is curved or bowed to form fit to the average baby's face. The shield 14 may be any shape that prevents it from being pulled into the subject's mouth from the suction force placed upon the nipple 12 by the subject. More preferably, the shield 14 will be shaped or include a reference indicator such that the top of the pacifier 10 can be readily determined by looking at the shield 14. In an alternative embodiment, the shield 14 preferably includes a plurality of holes (or relief openings) 142 to allow for spit to be discharged without interference from the pacifier 10 as illustrated, for example, in Figures 21(a), 23, and 24. Figure 21(b) illustrates a

relief opening 142' that allows insertion of a catheter such as an endotracheal tube. A further alternative is for the shield to include a mesh pattern over at least a portion of it. Another alternative embodiment adds a ring (or annular or other shaped handle) 16 on the opposite side of the shield 14 from the nipple 12 as illustrated in Figures 21(a) and 22 that may attach to either the shield 14 or the nipple 12. Preferably, the ring is hinged, collapsible, and/or flexible.

An alternative embodiment of the invention is the placement of the oximeter signal processing device within a housing 30 extending from the shield 14 on the side opposite the nipple 12 as illustrated, for example, in Figures 23 and 24. The oximeter signal processing device preferably is a miniature spectrophotometer. The oximeter signal processing device preferably will include a display 32, a power supply (such as a battery) 34, and a processor 36 to perform calculations and to drive the display 32, and an on-off button (or switch/mechanism) 38 as illustrated in Figure 25. The display 32 preferably will show the blood oxygenation level of the subject as illustrated in Figure 24. More preferably, the display 32 is a digital display. The processor 36 preferably will connect to the wiring 24 running from the pulse oximeter sensor elements 20, 22, calculate the blood oxygenation level, and drive both the display 32 and the light source 20. The processor 36 preferably is a circuit that includes either an analog circuit or an integrated circuit, which is either hardwired or programmed. Preferably, the display 32, the power supply 34, the processor 36 will reside on a printed circuit board that includes appropriate circuitry and provides a connection to wiring 24.

Another alternative embodiment of the invention is that the light source 20 and the light detector 22 may be in wireless communication with the external device instead of connected with the external cord 26 as illustrated in Figure 26 as a rod (or antenna or transmitter) 40. Alternatively, the antenna 40 may take the shape as a

handle 16 similar to the one illustrated, for example, in Figures 21 and 22 without the external cord 26. Preferably, the wireless communication will occur through an antenna 40 extending away from the pacifier 10. The transmitter may be incorporated within the antenna 40 or some other housing incorporated into the shield 14. Preferably, the antenna 40 will be sufficiently sturdy to withstand tugging and being played with during use by the subject. This alternative embodiment also preferably includes a power source such as a battery to power all of the electrical components. The power source preferably is located within the shield, a housing, or as part of the antenna 40.

A further alternative embodiment of the invention is to provide a bite block on the distal side of the shield 14 between the shield 14 and the nipple 12. The bite block may be an extension of the shield material or a hardened nipple shank 126. The flexible nipple 12 preferably is attached to the bite block. Preferably, the bite block will provide a passageway through which the wiring 24 may pass through. The shield 14 and nipple 12 preferably would be shaped such that multiple catheters would have space to enter the oral cavity, for example, for suction and supplying oxygen. This alternative embodiment preferably would be for use during surgery of a variety of subjects other than infants and young children.

The device may be a retrofit of current pacifiers by inserting the pulse oximeter sensor elements from a disposable pulse oximeter like the Nellcor® Oxisensor® II oximeters (Mallinckrodt, Inc., St. Louis, Missouri, U.S.A.) by stripping away the packaging and adhesive strip. The ring attached to most pacifiers would be removed leaving access to the interior cavity of the nipple into which the pulse oximeter sensor elements would be inserted such that they faced in the same general direction. The ring then would be reattached.

In accordance with the present invention, there is a method to take oximeter readings from different sites within a subject, which may be either human or animal, for the purposes of determining the amount of oxygen within the blood of the subject. The oximeter readings are accomplished using reflectance oximetry from capillary beds that are readily accessible within the subject. The capillary beds include, for example, the hard palate, the soft palate, the superior lingual surface, the inferior lingual surface, the gingivae, the mouth floor, the buccal surface, and any other surface within the oral cavity. Each of these capillary beds is accessible through the oral cavity, which extends from the lips to the oral portion of the pharynx, i.e., *pars oralis*.

Figure 27 illustrates a flowchart showing the steps for taking oximeter readings pursuant to the present invention. In the first step 110, which may actually occur at a later point but no later than the initiation of taking pulse oximeter readings, the pulse oximeter sensor elements are connected to an oximeter device such as a spectrophotometer. In step 120, the pacifier 10 is inserted into the subject through the mouth. The placement of the pacifier 10 with a pulse oximeter sensor is illustrated, for example, in Figures 17 and 18. In step 130, reflectance pulse oximeter readings are taken from the relevant capillary bed. While taking the pulse oximeter readings, the pulse oximeter sensor elements preferably remain in contact with the relevant capillary bed to continue the flow of accurate oximeter readings.

The method according to the invention may be used in a variety of surgical, anesthetic, critical care procedures or situations that include patients that are awake, sedated or recovering from general anesthesia.

The method of taking pulse oximeter readings from different surfaces within a patient has been submitted to actual testing in the below-described population and according to the following protocols.

Reflectance Oximetry from the Buccal Surface

The first protocol involved taking readings from the buccal surface. Nine patients were monitored via buccal reflectance pulse oximetry over 20 consecutive surgical procedures, which procedures consisted of burn excision and grafting. Patients ranged in age from 23 to 56 years (Mean = 264.8, Standard Deviation (SD) = 11.2) and ranged from 17 to 75 percent total body surface area (%TBSA) burned (Mean = 274.3%, SD = 28.9). Each patient received from one to eight operations (Mean = 4.01). Five of these nine patients arrived at the operating room intubated for all of the operations in this study. Four patients were induced and intubated in a standard fashion for all surgical procedures.

A Nellcor® Oxisensor® II D-25 was placed intraorally between the lower teeth and the left or right buccal surface of the cheek and lip, with the bispectral emitter and detector facing the buccal surface. This pulse oximeter sensor orientation was used for the duration of each case. In addition, a similar disposable oximetric probe was placed on a peripheral digit in the commonly accepted transillumination configuration. At five minute intervals throughout the case, values for both oximetric probes were coded on the anesthesia record.

The differences between the peripheral and buccal SpO<sub>2</sub> (oxygen saturation of hemoglobin) values were insignificant by *t*-tests for correlated means. Concordance rates as percent agreements were calculated for all cases. Average percent agreement was 84% ranging from 25% to 100%. Three of the 20 samples had percent agreements less than 91%. In each of these cases, the peripheral pulse oximeter sensor appears to have failed, in two cases secondary to sepsis, and in another secondary to peripheral vasoconstriction in the face of a norepinephrine infusion. Buccal SpO<sub>2</sub> readings in all three cases continued to be 97% or greater.

This data suggests that buccal reflectance oximetry is a simple, accurate means of monitoring arterial oxygen saturation in the severely burned patient where oximetric monitoring presents a challenge. Given that central oximetry has been shown in numerous studies to be more rapidly responsive to oxygen saturation variability than peripheral oximetry, as well as more directly reflective of central oxygen saturation, there are few drawbacks and considerable benefit from this method. Indeed, in the three examples in this study where percent agreements were low, the peripheral oximetric probes were returning apparently erratic and/or generally low values while buccal oximetric readings remained at 97% or higher. All three of these patients had peripheral vascular compromise secondary to sepsis and/or a vasoconstricting agent (norepinephrine infusion).

It may appear from the study results, at first blush, that a full range of SpO<sub>2</sub> values was not tested and that the continuously high SpO<sub>2</sub> readings are spurious to the technique. On the contrary, in order to obtain a SpO<sub>2</sub> value greater or less than 85% a very specific set of relationships must be present relative to the bispectral emitter and light sensing oximetric elements. Thus, spuriously high values in particular do not consistently occur. High SpO<sub>2</sub> values require the presence of saturated hemoglobin.

#### Posterior Pharyngeal Reflectance Oximetry

The second protocol involved comparing posterior pharyngeal reflectance pulse oximetry to conventional peripheral transillumination pulse oximetry in difficult to monitor burn patients. Eight patients' records were reviewed over fourteen consecutive surgical procedures, all consisting of excision and grafting. Patients ranged in age from 9 to 43 years and ranged from 14.5% to 77.5% TBSA burned (Mean = 30.4, SD = 22.1). The number of operations per patient ranged from one to four.

A Nellcor® Oxisensor® II pulse oximeter probe was placed in the distal lumen of an appropriately sized oropharyngeal airway with sensor and emitter facing the posterior pharynx. A similar probe was placed on a peripheral digit as a transilluminating pulse oximeter. SpO<sub>2</sub> values were noted at five-minute intervals. Concordance statistics as well as a *t*-test for correlated means were calculated between the simultaneously obtained SpO<sub>2</sub> values.

The mean differences between pharyngeal reflectance and peripheral digital transillumination SpO<sub>2</sub> values were insignificant for all cases. Concordance statistics were as follows: 0.75 (*n* = 1) and 1.0 (*n* = 12).

Given the near perfect concordance statistics in this study, this data suggests that posterior pharyngeal reflectance oximetry is a simple, highly accurate means of monitoring arterial oxygen saturation in the severely burned patient where oximetric monitoring presents a challenge.

#### Lingual Surface Reflectance Oximetry

The third protocol involved taking readings from the lingual surface. Data was reviewed for eight difficult to monitor patients who were monitored via lingual reflectance pulse oximetry over twenty-five consecutive surgical procedures, all consisting of burn excision and grafting. Patients ranged in age from 26 to 57 years (Mean = 36.0, SD = 10.3). Patients ranged from 20% to 92% TBSA burned (Mean = 66.75%, SD = 26.42). Number of operations per patient ranged from one to five (Mean = 3.13, SD = 1.55). Six of these eight patients arrived at the operating room intubated for all of the operations in this study. Two patients were induced and intubated in a standard fashion.

In each case, a Nellcor® Oxisensor® II D-25 was centered flat on the superior lingual surface with the detector and the bispectral emitter facing the lingual surface. This pulse oximeter configuration was used for the duration of each case. When

clinically indicated, an arterial blood gas (ABG) sample was drawn and the SpO<sub>2</sub> noted for clinical monitoring and prior to transfusion in every case. All had multiple ABG's drawn and all patients were transfused. The ABG SaO<sub>2</sub> (oxygen saturation of arterial blood) was noted in each case.

Descriptive statistics and a concordance rate as well as a *t*-test for correlated means were calculated between the simultaneously obtained SpO<sub>2</sub> and SaO<sub>2</sub> values. The difference between the SpO<sub>2</sub> and SaO<sub>2</sub> values was insignificant by *t*-test for correlated means (*t* = 1.25, *df* = 24, NS). Upon inspection, the means were very close and the standard deviations were very small, as were the SEM's, all suggesting very little difference or variability between these two measures of oxygen saturation. A concordance rate of 92% was calculated (+ 1.5%) showing a high degree of relationship between lingual and ABG SaO<sub>2</sub>.

This data suggests that lingual reflectance oximetry is a simple, accurate means of monitoring arterial oxygen saturation in the severely burned patient where oximetric monitoring presents a challenge. An existing disposable pulse oximeter sensor was utilized in this study saving the cost of specially designed equipment. Given that central oximetry has been shown to be more rapidly responsive to oxygen saturation variability than peripheral oximetry, there are few drawbacks and considerable benefit from this method.

## **VI. INDUSTRIAL APPLICABILITY**

The invention is particularly useful for monitoring the blood oxygen content of a subject, more particularly a child or infant. The invention is also useful when other sites are not available on the patient such as a patient with severe burns covering most of their body or a restless child who is prone to remove attached oximeters to fingers and other body parts. The invention may be used by hospital personnel, emergency

medical crews, in-home medical personnel, laboratory and veterinary personnel and battlefield medical personnel.

Those skilled in the art will appreciate that various adaptations and modifications of the above-described devices and steps can be configured without departing from the scope and spirit of their use in the method. Therefore, it is to be understood that, within the scope of the appended claims, the method may be practiced and arranged other than as specifically described herein. Furthermore, the above-described embodiments may be used in a variety of combinations.

## IN THE CLAIMS:

We claim

1. An oximeter sensor comprising:  
a nipple,  
a shield connected to said nipple, and  
oximeter sensor elements in said nipple; and  
wherein said oximeter sensor elements are arranged to perform reflectance pulse oximetry.
2. The device as recited in claim 1, wherein said oximeter sensor elements include:  
means for transmitting light at an intraoral tissue, and  
means for receiving light reflected from the intraoral tissue.
3. The device as recited in claim 2, wherein said means for transmitting and said means for receiving are embedded in said nipple.
4. The device as recited in claim 2, wherein  
said nipple includes an inner cavity, and  
said means for transmitting and said means for receiving are disposed in the inner cavity of said nipple.
5. The device as recited in claim 1, wherein said oximeter sensor elements include:  
at least one light source, and  
at least one light detector in communication with said at least one light source.
6. The device as recited in claim 5, wherein said light source includes one of at least one light emitter, a bispectral emitter, a dual spectral emitter, at least one photoemitter, at least one photodiode, at least one light emitting diode, and a semiconductor die.

7. The device as recited in claim 6, wherein said light detector includes one of a photoelectric receiver, a photodetector, a photodiode receiver, and a semiconductor die.

8. The device as recited in claim 6, wherein said nipple includes an inner cavity, and said light source and said light detector are disposed in the inner cavity of said nipple.

9. The device as recited in claim 7, wherein said light source and said light detector are embedded within said nipple.

10. The device as recited in claim 5, further comprising:  
a transmitter,  
a power source, and  
wiring connecting said light source, said light detector, and said transmitter to said power source, said wiring connecting said light source and said light detector to said transmitter.

11. The device as recited in claim 5, wherein said light source and said light detector are disposed near a top of said nipple.

12. The device as recited in claim 5, wherein said light source and said light detector are disposed near a tip of said nipple.

13. The device as recited in claim 5, wherein said light source and said light detector are disposed near a bottom of said nipple.

14. The device as recited in claim 5, further comprising an oximeter device, said oximeter device includes:

a display,  
a power supply connected to said display, and

a processor connected to said power supply and said display, said processor is in communication with said light source and said light detector; and

wherein said processor signals said light source to transmit light, and

said processor receives at least one signal from said light detector representing light detected by said light detector.

15. A method for using the device recited in claim 1 comprising:

connecting the device to an oximeter,

inserting the device into a mouth of a subject, and

taking reflectance pulse oximeter readings.

16. The device as recited in claim 1, further comprising a plug engaging said nipple and said shield such that at least a portion of said nipple is held in place between said plug and said shield.

17. The device as recited in claim 1, further comprising a bite block connecting said shield to said nipple.

18. An oximeter system comprising:

a spectrometer, and

a pacifier oximeter sensor having a nipple, a shield attached to said nipple, and pulse oximeter sensor elements within said nipple.

19. The oximeter system according to claim 18, wherein said pulse oximeter sensor elements include a light source and a light detector.

20. A pulse oximeter sensor comprising:

means for restricting inward suction of the pulse oximeter sensor into a subject,

means for performing reflectance pulse oximetry inside the subject, and

means for housing said oximetry means.

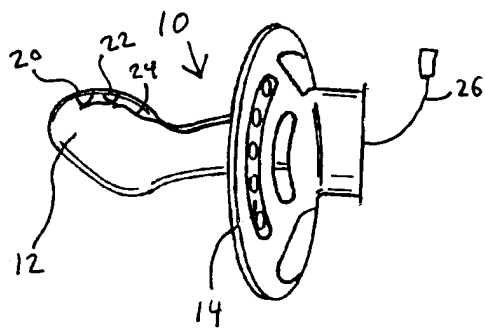

Fig. 1

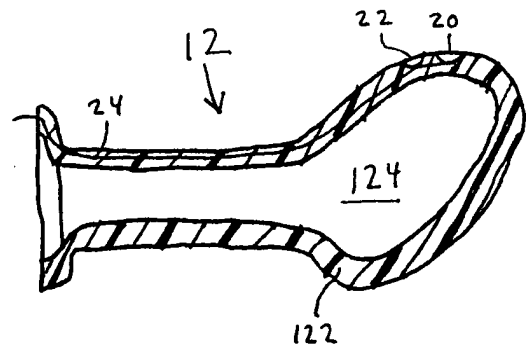

Fig. 2

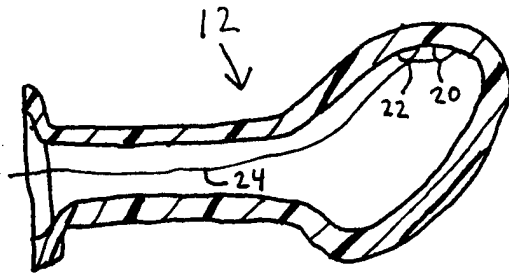

Fig. 3

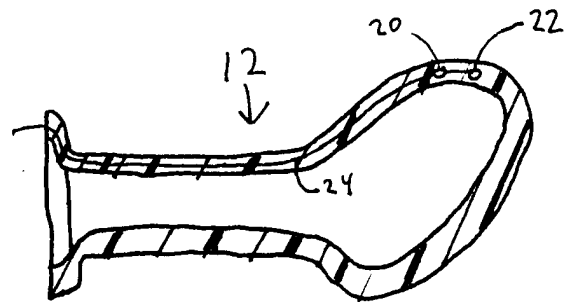

Fig. 4

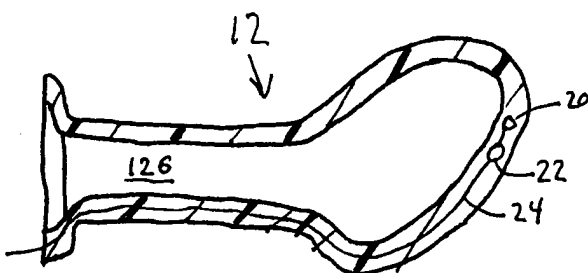

Fig. 5

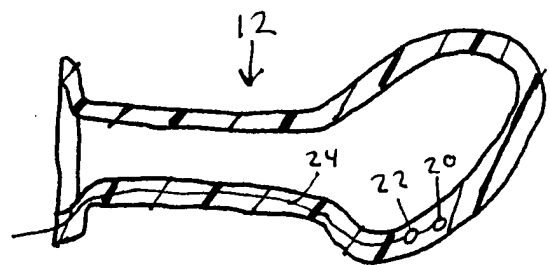

Fig. 6

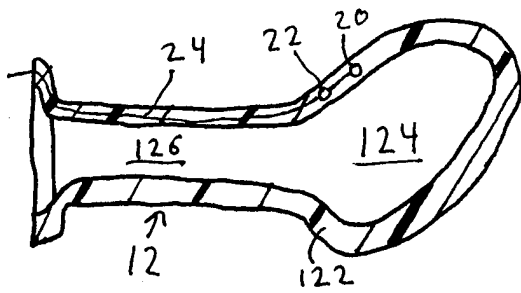

Fig. 7

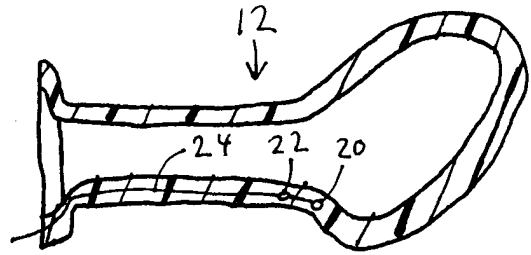

Fig. 8

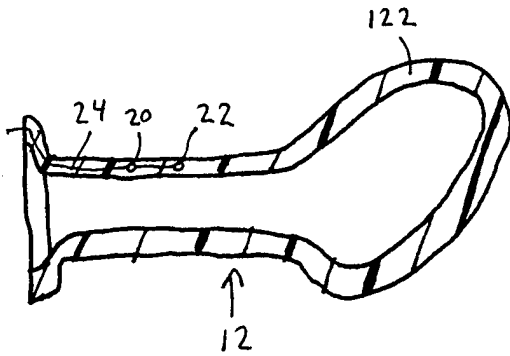

Fig. 9

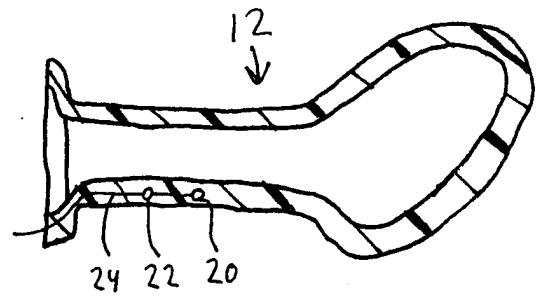

Fig. 10

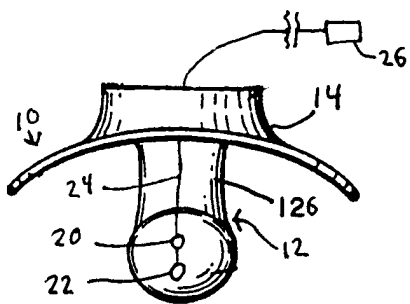

Fig. 11

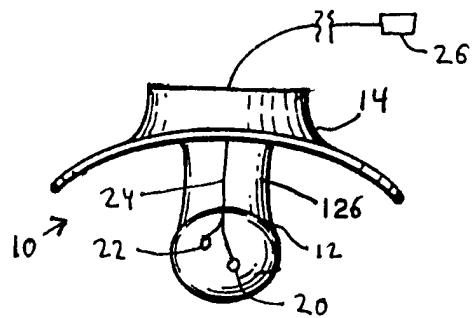

Fig. 12

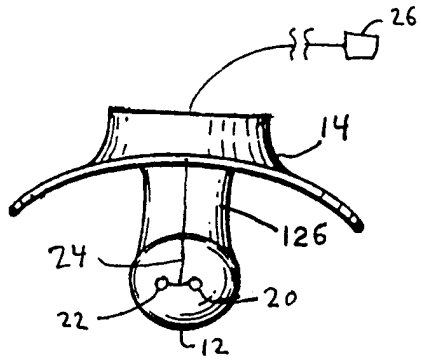

Fig. 13

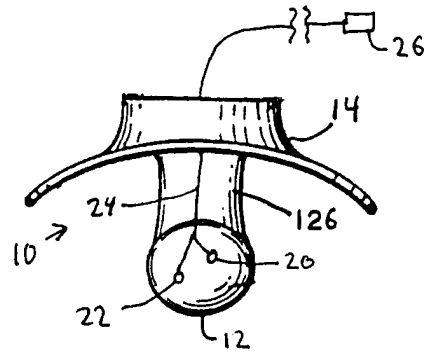

Fig. 14

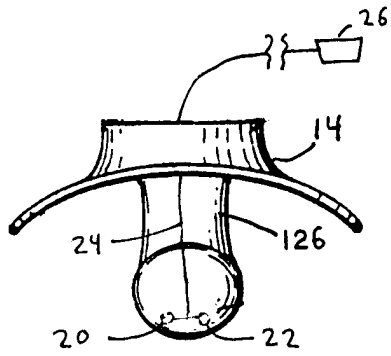

Fig. 15

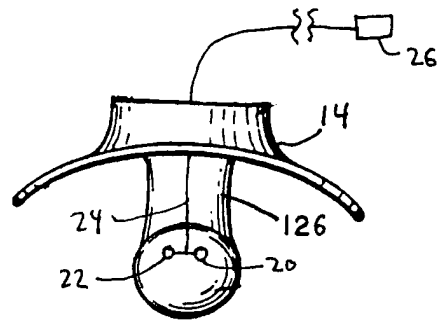

Fig. 16

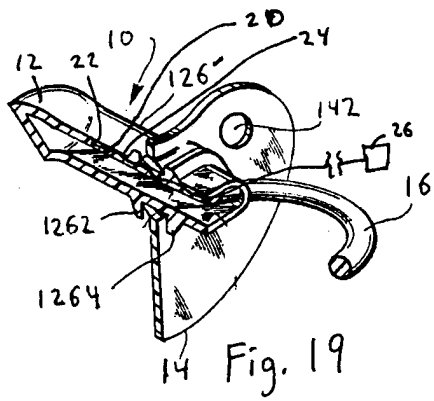

Fig. 19

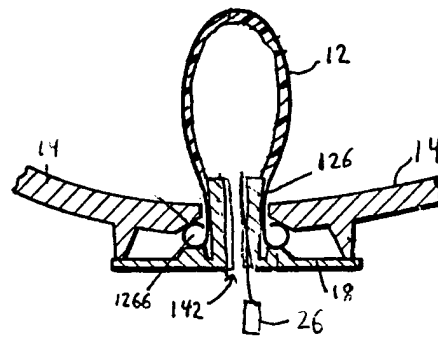

Fig. 20

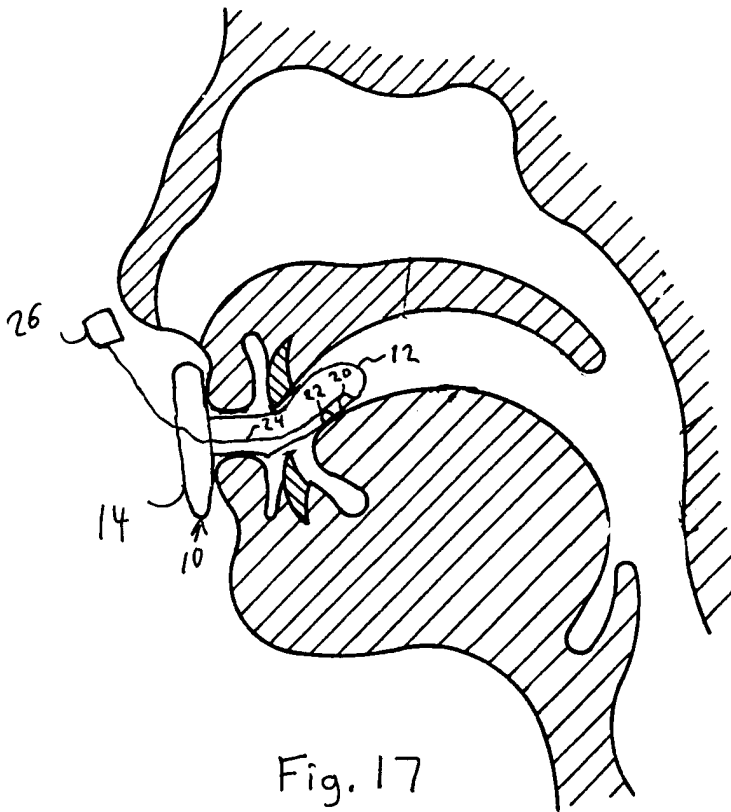

Fig. 17

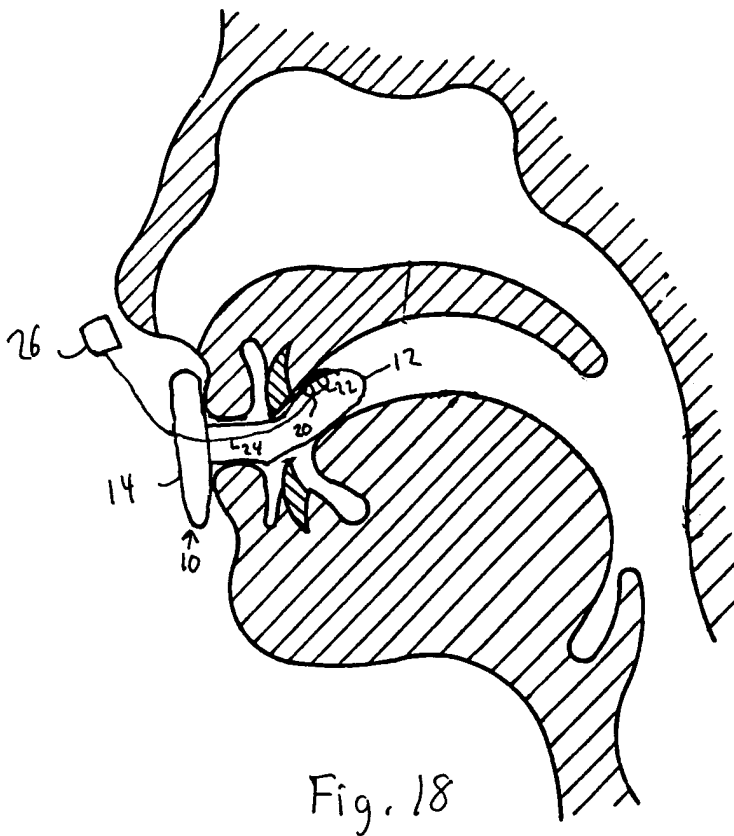

Fig. 18

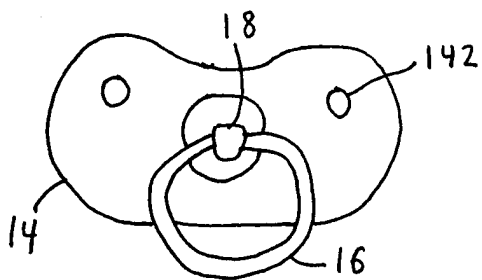

Fig. 21(a)

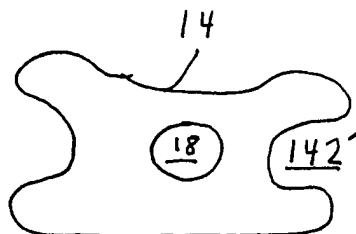

Fig. 21(b)

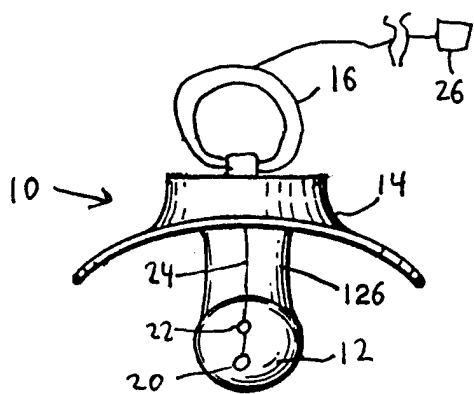

Fig. 22

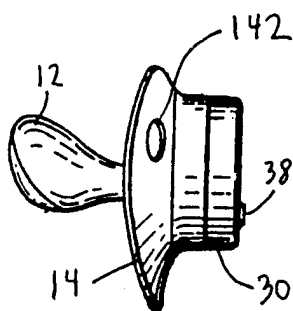

Fig. 23

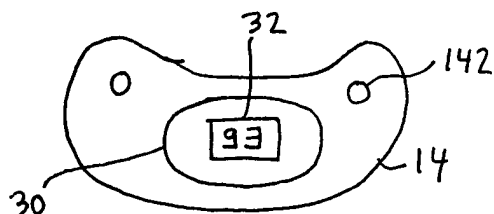

Fig. 24

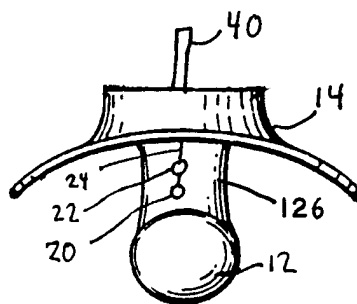

Fig. 26

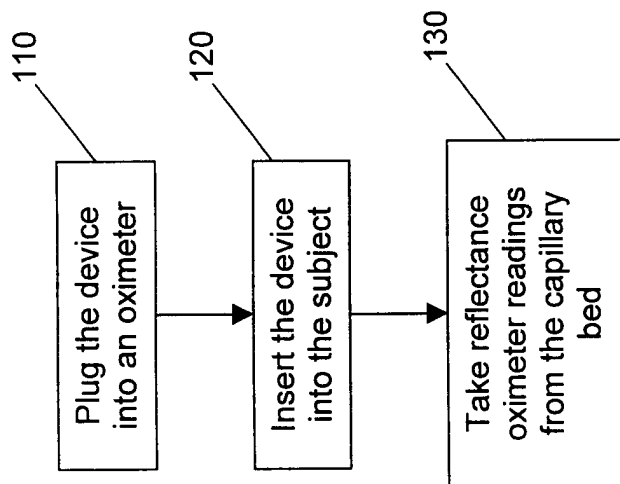

Fig. 27

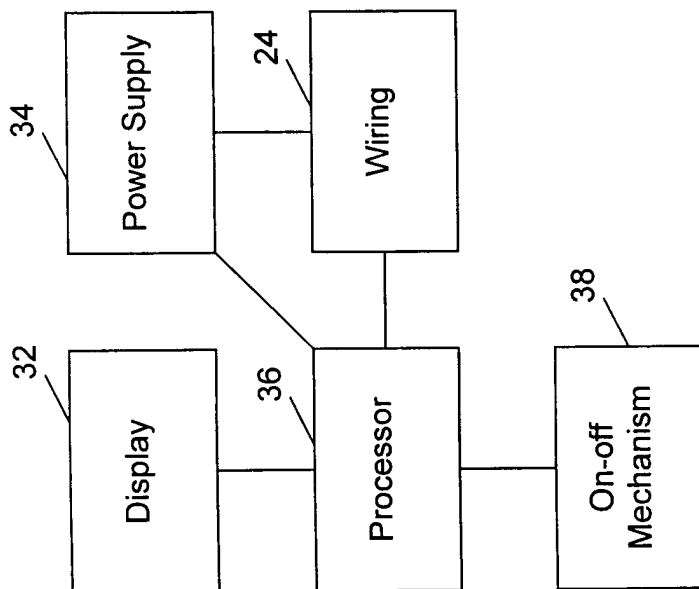

Fig. 25

# INTERNATIONAL SEARCH REPORT

International Application No  
PCT/US 01/04343

**A. CLASSIFICATION OF SUBJECT MATTER**  
IPC 7 A61B5/00

According to International Patent Classification (IPC) or to both national classification and IPC

**B. FIELDS SEARCHED**

Minimum documentation searched (classification system followed by classification symbols)  
IPC 7 A61B

Documentation searched other than minimum documentation to the extent that such documents are included in the fields searched

Electronic data base consulted during the international search (name of data base and, where practical, search terms used)

EPO-Internal, WPI Data, PAJ, INSPEC, COMPENDEX

**C. DOCUMENTS CONSIDERED TO BE RELEVANT**

Category °	Citation of document, with indication, where appropriate, of the relevant passages	Relevant to claim No.
Y A	WO 83 02664 A (CHRISTOFFERSEN STEEN RUPERT) 4 August 1983 (1983-08-04) page 2, line 29 - line 12 ---	1-12,14, 18-20 13,16
Y A	OGINO H ET AL: "REFLECTANCE PULSE OXIMETER MEASURING CENTAL SAO2 FROM MOUTH" PROCEEDINGS OF THE ANNUAL INTERNATIONAL CONFERENCE OF THE IEEE ENGINEERING IN MEDICINE AND BIOLOGY SOCIETY,US,NEW YORK, IEEE, vol. 16, 3 November 1994 (1994-11-03), pages 914-915, XP000552397 ISBN: 0-7803-2051-4 section "The RPS System" --- -/--	1-12,14, 18-20       17

Further documents are listed in the continuation of box C.

Patent family members are listed in annex.

° Special categories of cited documents :

- \*A\* document defining the general state of the art which is not considered to be of particular relevance
- \*E\* earlier document but published on or after the international filing date
- \*L\* document which may throw doubts on priority claim(s) or which is cited to establish the publication date of another citation or other special reason (as specified)
- \*O\* document referring to an oral disclosure, use, exhibition or other means
- \*P\* document published prior to the international filing date but later than the priority date claimed

- \*T\* later document published after the international filing date or priority date and not in conflict with the application but cited to understand the principle or theory underlying the invention
- \*X\* document of particular relevance; the claimed invention cannot be considered novel or cannot be considered to involve an inventive step when the document is taken alone
- \*Y\* document of particular relevance; the claimed invention cannot be considered to involve an inventive step when the document is combined with one or more other such documents, such combination being obvious to a person skilled in the art.
- \*&\* document member of the same patent family

Date of the actual completion of the international search

Date of mailing of the international search report

13 June 2001

22/06/2001

Name and mailing address of the ISA

European Patent Office, P.B. 5818 Patentlaan 2  
NL - 2280 HV Rijswijk  
Tel. (+31-70) 340-2040, Tx. 31 651 epo nl,  
Fax: (+31-70) 340-3016

Authorized officer

Knüpling, M

INTERNATIONAL SEARCH REPORT

International Application No

PCT/US 01/04343

C.(Continuation) DOCUMENTS CONSIDERED TO BE RELEVANT

Category *	Citation of document, with indication, where appropriate, of the relevant passages	Relevant to claim No.
A	FR 2 729 843 A (DUPONT BERTRAND) 2 August 1996 (1996-08-02) page 3, line 33 -page 4, line 14 -----	1,15,18, 20
A	LEMA GUILLERMO E.: "Oral pulse oximetry in small children" ANESTHESIA AND ANALGESIA, vol. 72, no. 3, March 1991 (1991-03), page 414 XP001009431 New York, USA the whole document -----	1,15,18, 20

# INTERNATIONAL SEARCH REPORT

International Application No.  
PCT/US 01/04343

Patent document cited in search report	Publication date	Patent family member(s)	Publication date
WO 8302664    A	04-08-1983	DK    35682 A	26-09-1983
		AT    29299 T	15-09-1987
		AU    1109183 A	12-08-1983
		DE    3373342 D	08-10-1987
		EP    0099380 A	01-02-1984
		JP    59500202 T	16-02-1984
FR 2729843    A	02-08-1996	NONE	

专利名称(译)	安抚奶嘴脉搏血氧仪传感器		
公开(公告)号	<a href="#">EP1257191A1</a>	公开(公告)日	2002-11-20
申请号	EP2001909084	申请日	2001-02-12
[标]申请(专利权)人(译)	美陆军INST手术的Res		
申请(专利权)人(译)	美国陆军学院外科研究的		
当前申请(专利权)人(译)	美国陆军学院外科研究的		
[标]发明人	WALKER STEVEN C ALEXANDER JOHN G SHEPHERD JOHN M		
发明人	WALKER, STEVEN, C. ALEXANDER, JOHN, G. SHEPHERD, JOHN, M.		
IPC分类号	A61B5/00		
CPC分类号	A61B5/14552 A61B5/412 A61B5/682 A61B5/6855 A61B5/6896 A61J17/001 A61J17/1012 A61J17/105		
代理机构(译)	庆祝活动, JENTSCHURA & PARTNER		
优先权	60/182018 2000-02-11 US		
外部链接	<a href="#">Espacenet</a>		

#### 摘要(译)

奶嘴脉搏血氧计传感器包括位于奶嘴(10)的奶嘴内的脉冲血氧计传感器元件(20,22)。脉冲血氧计传感器元件(20,22)可以完全在乳头(12)材料内,嵌入乳头材料内,嵌套在乳头材料内,或邻近乳头材料,同时不暴露于外部环境。脉冲血氧计传感器元件(20,22)包括光源(20)和光检测器(22)。脉冲血氧计传感器元件(20,22)通过布线(24),电连接器和/或无线地与血氧计通信。替代实施例将测定仪处理能力添加到安抚奶嘴脉搏血氧计传感器。