



(12) **EUROPEAN PATENT APPLICATION**

(43) Date of publication:
29.08.2018 Bulletin 2018/35

(21) Application number: **18156996.3**

(22) Date of filing: **17.11.2008**

(51) Int Cl.:
A61B 5/00 (2006.01) **A61B 5/01 (2006.01)**
A61B 5/026 (2006.01) **A61B 5/0488 (2006.01)**
A61B 5/083 (2006.01) **A61B 5/11 (2006.01)**
A61B 5/1455 (2006.01) **A61F 7/102 (2006.01)**
A61F 7/100 (2006.01)

(84) Designated Contracting States:
AT BE BG CH CY CZ DE DK EE ES FI FR GB GR HR HU IE IS IT LI LT LU LV MC MT NL NO PL PT RO SE SI SK TR

(30) Priority: **16.11.2007 US 988706 P**

(62) Document number(s) of the earlier application(s) in accordance with Art. 76 EPC:
08849920.7 / 2 209 525

(71) Applicant: **Medivance Incorporated**
Louisville, CO 80027 (US)

(72) Inventors:

- **VOORHEES, Marc**
Arvada, CO 80005 (US)

- **CARSON, Gary A.**
Golden, CO 80401 (US)
- **GRUSZECKI, Gary**
Golden, CO 80403 (US)

(74) Representative: **D Young & Co LLP**
120 Holborn
London EC1N 2DY (GB)

Remarks:

This application was filed on 15-02-2018 as a divisional application to the application mentioned under INID code 62.

(54) **PATIENT TEMPERATURE RESPONSE CONTROL SYSTEM**

(57) A system is provided that employs a monitoring device to monitor at least one patient physiological response to a change in temperature of the patient (e.g. pursuant to induced hypothermia therapy), wherein a monitoring signal is provided by the monitoring device. In turn, an output (e.g. a visual and/or auditory output) may be provided to a user indicative of at least one measure of patient response to the change in temperature. A processor is provided to process the monitoring signal to provide an output employable by medical personnel to control a patient shivering response to the patient temperature change. Such information may comprise information regarding one or more anti-shivering medicament(s), e.g. corresponding dosage and/or frequency information for use by medical personnel in the administration of the anti-shivering medicament.

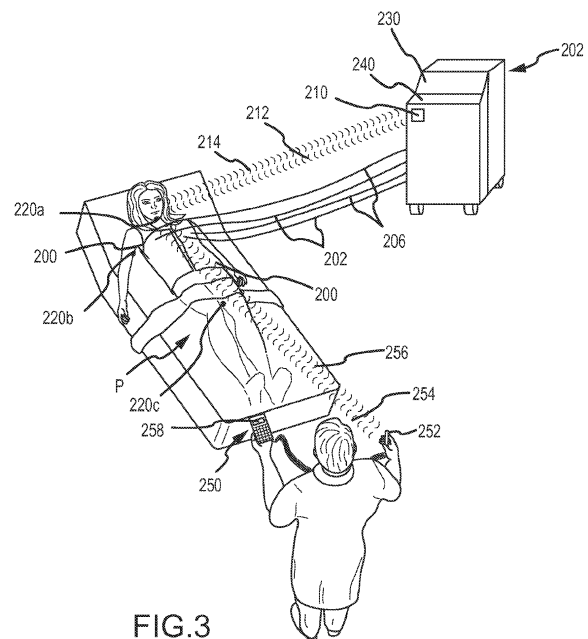

FIG.3

Description**RELATED APPLICATIONS**

[0001] This application claims priority to U.S. Patent Provisional Application Serial No. 60/988,706, filed November 16, 2007, entitled "PATIENT TEMPERATURE RESPONSE CONTROL SYSTEM AND METHOD", the entirety of which is hereby incorporated by reference.

FIELD OF THE INVENTION

[0002] The present invention relates to the field of induced hypothermia, and in particular, to a system and method that facilitates the control of patient shivering discomfort associated with induced hypothermia therapy.

BACKGROUND OF THE INVENTION

[0003] Hypothermia is a condition in which body temperature is at a level lower than normal body temperature. Therapeutic induced mild-moderate hypothermia can be beneficial for people suffering stroke, myocardial infarction, cardiac arrest serious head trauma and other conditions involving reduced blood supply. One method for lowering body temperature is to insert a cooling device into an artery of the patient and to internally cool the patient's body by introducing a cooling fluid into the device. A non-invasive technique for lowering body temperature is to externally cool the exterior surface of the patient's body. Such exterior surface cooling could be achieved, for example, by direct contact with a cooling fluid, such as by immersing the patient's body in the cooling fluid or by directing the flow of the cooling fluid around the patient's body. The cooling fluid could be, for example, cool water or cool air. Another technique for external surface cooling is to apply a contact-cooling pad to the exterior surface of the patient and to circulate a cooling fluid, such as water or an aqueous solution, through the contact pad to cool the patient.

[0004] For therapeutic purposes, it is often desirable for the mild-moderate hypothermia to be induced very quickly. With endovascular cooling, heat is removed directly from blood flowing through blood vessels. Blood with reduced temperature moves through blood vessels to cool other parts of the body. With exterior surface cooling, heat is removed across the patient's skin. Cooling of the skin increases conduction of heat from deeper within the body, thereby cooling internal body tissue. Blood moving through blood vessels in a cooled portion of the body is also cooled, and distribution of that cooled blood to other parts of the body thereby contributes to cooling other parts of the body.

[0005] Quick inducement of hypothermia requires that the patient's body temperature be rapidly reduced to the desired level, and involves a high rate of transfer of heat from the body. Impediments to inducing hypothermia include the patient's thermoregulatory responses to cool-

ing. Shivering is a common thermoregulatory response that, in some cases, can increase body heat production to as much as 600% above basal levels. Anti-shivering drugs, and particularly meperidine, have been administered prior to or during active cooling to help suppress the shivering response. Such pharmacological treatment to suppress shivering is often successful, resulting in more rapid lowering of the patient's body temperature to more quickly induce a desired degree of hypothermia, reducing patient tiring attendant to shivering, and also reducing patient discomfort associated with shivering.

SUMMARY OF THE INVENTION

[0006] In view of the foregoing, one objective of the present invention is to facilitate control over, and thereby reduce, patient shivering (e.g. in response to induced hypothermia).

[0007] A related objective of the present invention is to facilitate a reduction in patient shivering, and attendant patient heat production, patient tiring and patient discomfort (e.g. in induced hypothermia procedures) via a system and method that provide an output to facilitate anti-shivering response by medical personnel and that otherwise exhibit user-friendly functionalities.

[0008] Yet another objective is to facilitate a reduction in patient shivering (e.g. during induced hypothermia procedures) in a manner that enhances the efficiency of medical personnel in the performance of thermotherapy related activities.

[0009] One or more of the above objectives and additional advantages may be realized in a medical apparatus that includes a monitoring device for monitoring patient shivering or at least one physiological response of a patient to a change in the temperature of the patient and to provide a monitoring signal responsive thereto. The inventive apparatus may further include an output device for providing an output to a user responsive to the monitoring signal. In this regard, the output may be indicative of at least one measure of a physiological response, such as a magnitude, degree or progressive stage of shivering and/or information regarding potential response treatment option(s). By way of example, a visual and/or auditory output may be provided to a user that indicates that a predetermined level or stage of shivering has been detected and/or other information that may be useful in addressing a detected patient shivering condition.

[0010] In one aspect, the medical apparatus may further comprise at least one of an energy storage device and a wireless energy conversion device, interconnected to the monitoring device, for powering the monitoring device. In one approach, a wireless signal receiver and rectifier arrangement may be employed for receiving a wireless signal and transducing electrical energy therefrom to power the monitoring device. In conjunction with such approach, a wireless signal transmitter may be employed for transmitting a wireless signal corresponding with the monitoring signal. Alternatively, a transceiver may be em-

ployed for both receiving a wireless signal and transmitting a wireless signal corresponding with the monitoring signal.

[0011] In another approach, a battery may be employed as an energy storage device for powering the monitoring device. In conjunction with such approach, the battery may be interconnected with a transmitter for transmission of a wireless signal corresponding with the monitoring signal. Further, when a rechargeable battery is employed, a wireless signal receiver and rectifier may be included to transduce electrical energy from a wireless charging signal for recharging the rechargeable battery.

[0012] In conjunction with either of the above-noted approaches, an energy storage device and/or wireless energy conversion device may be interconnected to a monitoring device for co-movement therewith. More particularly, such components may be directly connected or interconnected to a common support member for co-movement, free from hardwire or other physical interconnections with a power source.

[0013] In a related aspect, the monitoring device may be non-invasive. In turn, use of the monitoring device may be initiated without compounding patient anxiety, patient tiring or patient discomfort otherwise attendant to the use of invasive devices.

[0014] In a further related aspect, the monitoring device may be provided to be selectively interconnectable to and disconnectable from a patient. When connected, the monitoring device may be maintainable in fixed relation to a given location on a patient. By way of example, the monitoring device may be interconnectable to a patient via a hook and loop fastener arrangement, a peel and stick adhesive surface arrangement or other like techniques.

[0015] In one approach, the monitoring device may comprise at least one motion sensor, e.g. an accelerometer selectively interconnectable/disconnectable to a patient, e.g. adhesively connectable to a patient's jaw (e.g. the masseter region). Such accelerometer(s) may be provided to measure acceleration in one and/or a plurality of orthogonal axes (e.g. one, two or three orthogonal axes).

[0016] In conjunction with such approach, a plurality of accelerometers may be interconnected to a patient at different locations to provide separate monitoring signals that may be employed together to facilitate the provision of an output indicative of a magnitude, degree or stage of patient shivering. For example, accelerometers may be separately interconnected to a patient's jaw (e.g. the masseter region), to a patient's chest (e.g. the pectoral region), to a patient's arm (e.g. the bicep region) and/or to a patient's leg (e.g. the quadriceps region), wherein corresponding monitoring signals from such accelerometers may be utilized to monitor a degree and for progressive stage of shivering. In this regard, each of the monitoring signals may comprise pre-determined signal portions (e.g. corresponding with a predetermined motion frequency range or ranges) whose presence and/or

magnitude may be identified and utilized to generate a user output.

[0017] In another approach, the monitoring device may comprise a vasoconstriction measurement device for measuring blood flow at two to offset locations, e.g. at a fingertip and at corresponding forearm. In an additional approach, the monitoring device may comprise one or more electromyography (EMG) surface sensors for monitoring muscular electrical activity. In another approach, the monitoring device may comprise a pulse oximeter sensor for monitoring blood oxygen saturation levels of a patient. In yet a further approach, the monitoring device may comprise one or more capnography input sensors for concentration and/or partial pressure of carbon dioxide in patient respiratory gases.

[0018] In relation to each of these approaches, the monitored parameter may have a known relationship to patient shivering, wherein a magnitude of the measured parameter may be related to a corresponding degree or stage of patient shivering. Further, in relation to such approaches, a plurality of sensors that measure the same parameter and/or different ones of the noted parameters may be employed to combinatively yield a monitoring signal.

[0019] In certain embodiments, a processor and/or logic circuit may be employed to process one or more monitoring signal(s) to generate an output control signal for controlling an output device. In this regard, one or more predetermined algorithms may be employed for frequency domain processing and/or time domain processing of one or a plurality of monitoring signal(s) provided by one or a plurality of motion monitoring device(s) (e.g. one or a plurality of accelerometer(s)).

[0020] In one approach, a monitoring signal comprising three-dimensional accelerometer output data values may be processed utilizing a frequency domain transfer algorithm. In this regard, successive overlapping frames of data sets which each comprise three dimensional acceleration data values may be deinterleaved into three data sets corresponding with each of the three dimensions, windowed (e.g. utilizing a Kaiser or other windowing technique) and transformed utilizing a frequency transform technique (e.g. a Fourier transform). A square of the modulus of the transformed data may be determined, and the results thereof may be summed to yield spectral data for each frame of data. In turn, the spectral data for a plurality of frames may be analyzed in relation to a plurality of predetermined frequency ranges to assess a magnitude or degree of patient shivering, wherein at least one of the predetermined frequency bands includes a frequency level indicative of patient shivering (e.g. a band including a frequency level of about 9.5Hz).

[0021] In another aspect, the processor may be pre-programmed to process the monitoring signal and provide information for use in administering at least one anti-shivering medicament to a patient. By way of example, such information may comprise the identification of one or more anti-shivering medicaments employable by med-

ical personnel in controlling patient shivering. Further, the output may comprise information corresponding with dosage and/or administration frequency of one or more anti-shivering medicaments. In one approach, dosage and frequency information may be based upon, at least in part, a monitored magnitude of patient shivering, as reflected by the monitoring signal.

[0022] The anti-shivering medicament may comprise one or more substance effective for suppressing shivering. A variety of such anti-shivering medicaments are known or may be identified in the future. Examples of some reported anti-shivering medicaments include certain non-opioid analgesics (e.g. tramadol and nefopam), certain opioid analgesics (e.g. alfentanil, morphine, fentanyl, meperidine, naloxone and nalbuphine), certain α_2 -adrenergic agonists (e.g. clonidine and dexmedetomidine) and certain serotonin antagonists (e.g. ketanserin and ondansetron). Also, multiple anti-shivering medicaments may be used to the extent they are pharmacologically compatible. Moreover, it should be appreciated that medicaments are often administered in the form of pharmacologically acceptable salts, so, for example, the anti-shivering medicament may be such a salt of any of the foregoing listed compounds. Meperidine, or a salt thereof, is particularly preferred for use as the anti-shivering drug.

[0023] Given the variety of anti-shivering medicaments that may be employable, and in another aspect, the processor may be preprogrammed to generate information, at least in part, in accordance with a user-established protocol that specifies one or more user-preferred anti-shivering medicaments and that comprises data and/or algorithms that provide for the automated generation of an output regarding dosage and/or frequency information for the preferred medicament(s). For example, a given user may pre-establish a protocol that contemplates the use of a particular medicament and a corresponding dosage amount and/or frequency of dosage administration rate, as well as a preset correlation between such data and measured magnitude(s) of monitored patient response to temperature change (e.g. a monitored magnitude of patient shivering).

[0024] In an additional aspect, the processor may be operable to process the monitoring signal to assess a given patient's shivering response to at least one prior administration of an anti-shivering medicament, and in turn, to provide output comprising updated information employable in a subsequent administration of the same or different anti-shivering medicament. Stated differently, the processor may process the monitoring signal on an ongoing basis so as to establish trend data corresponding with a patient's response to a given anti-shivering medicament, and in turn, to utilize such trend data in the provision of further updated information regarding a recommended dosage in/or frequency for one or more subsequent administration(s) of an anti-shivering medicament.

[0025] In another aspect, the apparatus may include a

user interface as an output device for providing output information in at least one of an audible and visual form. By way of example, the information may be provided via an interactive display. In turn, the interactive display may be provided to receive user input, e.g. to identify an anti-shivering medicament and/or to establish a protocol for subsequent use in generating an information output in a given thermotherapy procedure.

[0026] As noted above, the monitoring device(s) may be adapted to provide the monitoring signal(s) as a wireless signal(s). In turn, the apparatus may include a receiver, interconnected to a processor, for receiving a wireless monitoring signal and providing the signal to the processor. In turn, the process may process the monitoring signal(s) as indicated above.

[0027] In yet another aspect, the processor may be operable to employ the monitoring signal in conjunction with the generation of an input signal that is provided to a temperature control system (e.g. a system for cooling and/or warming a patient). For example, the input signal may be utilized in conjunction with establishing the temperature of a cooling medium utilized to cool a patient.

[0028] An inventive method is also provided for use in controlling a shivering response of a patient during therapeutic patient cooling. The method may comprise the steps of monitoring at least one physiological response of a patient to a change in temperature of the patient, and automatically providing an output responsive to the monitoring signal.

[0029] In one approach, the output may be indicative of at least one measure of the patient shivering response. For example, the output may comprise a visual and/or audible output indicating to a user a predetermined magnitude, degree and/or stage of patient shivering. In another approach, the output may be based at least in part on a monitored response for employment by a user in controlling the patient's shivering response to a temperature change. For example, the output may comprise information regarding the dosage and/or frequency of administration of an anti-shivering medicament.

[0030] In one aspect, the method may further include the step of powering the monitoring device by at least one of an energy storage device and a wireless energy conversion device (e.g. comprising a receiver antenna and rectifier) interconnected to the monitoring device for co-movement therewith. By way of example, the monitoring device (e.g. a motion sensor) and an energy storage device and/or a wireless energy conversion device may each be interconnected to a common support structure (e.g. a printed circuit board located within a protective housing), wherein an adhesive backing may be provided on the support structure with a removable liner to facilitate selective interconnection to and disconnection from a patient.

[0031] In a further aspect, the method may include the steps of transmitting the monitoring signal as a wireless signal, and receiving the wireless monitoring signal for use in the providing step. Further, the powering step may

include converting a wireless power signal to an electrical signal utilizing a wireless energy conversion device, wherein the electrical signal provides power to the monitoring device for use in the monitoring step and to a transmitter for use in the transmitting step.

[0032] In a further aspect, the monitoring step may include utilizing a motion sensor interconnected to a patient to provide a monitoring signal that is indicative of patient motion. In turn, the providing step may include processing of motion data comprising the monitoring signal utilizing frequency domain processing. By way of example, the motion data may include three-dimensional accelerometer data. The processing step may include the steps of windowing the three-dimensional motion data, and transforming the windowed three-dimensional motion data to frequency domain data. In turn, a statistical analysis may be performed on the frequency domain data in a relation to a plurality of predetermined frequency bands.

[0033] In yet another aspect, the monitoring step may comprise at least one of monitoring motion of the patient (e.g. shivering-related motion), monitoring vasoconstriction of the patient (e.g. based on relative blood flow measurements at offset vascular locations), monitoring muscular electrical activity of the patient (e.g. using EMG surface sensors), monitoring carbon dioxide concentration and/or partial pressure of respiratory gases of the patient, and/or monitoring blood oxygen saturation levels of the patient. By way of example, a motion sensor may be selectively interconnected to a patient to monitor a magnitude of patient shivering and to provide a monitoring signal reflective thereof. In turn, the generating step may entail a comparison of the monitored shivering magnitude value to one or more preset, reference values. For example, a comparison may yield an indication of moderate shivering magnitude, which in turn may yield an output that indicates that administration of a moderate dosage of a given anti-shivering medicament may be in order.

[0034] In another aspect, the method may include the step of administering at least one anti-shivering medicament. For example, the medicament may be administered in accordance with output information that comprises dosage and/or frequency information for one or more identified anti-shivering medicaments.

[0035] In a related aspect, following administration of an anti-shivering medicament, the method may provide for repeating the monitoring and processing steps a plurality of times, on an ongoing basis during induced thermo therapy, and utilizing data inputted by a user that corresponds with the prior administering step (e.g. the time and dosage of administration) in a subsequently performed processing step to provide updated output information employable in a subsequent administering step. Stated differently, after the administration of a given anti-shivering medicament, the monitoring and processing steps may establish trend data regarding a patient's response to the anti-shivering medicament. In turn, such trend data may be utilized in the further generation of an

output reflecting dosage and/or frequency information for the further administration of an anti-shivering medicament.

[0036] In another aspect, the generating step of the inventive method may comprise utilizing patient specific data provided by a user. For example, a user may input data regarding a patient's age, weight, sex, physical condition and/or other patient specific data that may impact the type, amount and/or frequency of medicament administration.

[0037] In a further related aspect, the method may provide for outputting information to a user in at least one of a visual form and an audible form. Relatedly, an interactive user interface may be provided for receiving input from a user for use in completing the generating step.

[0038] Additional aspects and advantages in the present invention will be apparent to those skilled in the art upon consideration of the further description that follows.

BRIEF DESCRIPTION OF THE DRAWINGS

[0039]

Fig. 1 is a schematic illustration of one apparatus embodiment of the present invention.

Fig. 2 is a process flow diagram of one method embodiment of the present invention.

Fig. 3 illustrates a system embodiment comprising the present invention.

Fig. 4 illustrates one embodiment of a monitoring device employable in the system embodiment of Fig. 3.

Fig. 5 illustrates one embodiment of an output device employable in conjunction with implementations of the present invention.

Fig. 6 illustrates the output embodiment device of Fig. 5.

Figs. 7A, 7B and 7C illustrate perspective views of a motion sensor embodiment and component parts thereof employable to generate a monitoring signal in conjunction with implementations of the present invention.

Figs. 8A, 8B, 8C and 8D illustrate steps corresponding with a frequency domain processing embodiment for processing a monitoring signal in one embodiment of the present invention.

Figs. 9A, 9B and 9C illustrates steps of a time domain processing embodiment for processing a monitoring signal in one embodiment of the present invention.

DETAILED DESCRIPTION

[0040] Fig. 1 illustrates one embodiment of the present invention. As shown, a monitoring device **10** is provided to monitor at least one physiological response **R** of a patient **P** to a change of temperature of the patient and to provide a monitoring signal **12** responsive thereto. By

way of example, therapeutic hypothermia may be induced by a cooling system **50**. Cooling system **50** may comprise any of a number of different modalities for selective cooling of a patient, including for example cooled contact pads, vascular cooling, patient emersion approaches and/or other systems for rapidly cooling a patient, e.g. systems as described in U.S. Patent Nos. 6,669,715, 6,827,728, 6,375,674, and 6,645,232, and published PCT Application PCT/US2007/066893, hereby incorporated by reference in their entirety.

[0041] With further reference to Fig. 1, the monitoring signal **12** may be provided to a processor and/or logic circuit **20** via a hardwire and/or wireless interface between monitoring device **10** and processor and/or logic circuit **20**. In turn, processor and/or logic circuit **20** may be preprogrammed or otherwise provided to utilize the monitoring signal **12** to provide an output **22**.

[0042] In one approach, processor and/or logic circuit **20** may be provided to assess the monitoring signal **12** and provide an output **22** employable to indicate at least one measure of a shivering response of a patient. For example, the output **22** may be employable to provide a visual and/or audible output at a user interface **30** or other output device (e.g. one or more lights (e.g. one or more light emitting diodes) co-located with the patient P), wherein such output provide a user with an indication of a magnitude, degree and/or stage of a patient shivering response to a cooling therapy.

[0043] In another approach, an output **22** may be provided that is employable for use in controlling a shivering response of the patient P to changes of the bodily temperature of the patient P. In one embodiment, an output **22** may be provided at user interface **30** which comprises information that corresponds with one or more approaches for controlling patient shivering response via the administration of one or more anti-shivering medicaments.

[0044] By way of example, processor **20** may comprise preprogrammed logic, or algorithms/data, in a treatment module **24** for processing the monitoring signal **12** to provide an output **22** comprising information relating to one or more anti-shivering medicament administration actions that may be followed by medical personnel to treat patient shivering response to bodily cooling. In this regard, the treatment module **24** may comprise stored data/algorithms in relation to a plurality of preset treatment protocols, including protocols that have been established by a user, e.g. via user input at interface **30**. For example, each pre-established protocol may include data/algorithms relating to one or more of the following:

- Data corresponding with different anti-shivering medicament option(s), including different types and/or combinations of anti-shivering medicaments; and
- Dosage/frequency data and/or algorithms for each anti-shivering medicament option.

[0045] As may be appreciated, the processor **20** and

the user interface **30** may be provided for interactive operations therebetween. More particularly, in conjunction with a given patient cooling procedure, a user may utilize user interface **30** to access and select a given one of a plurality of treatment protocols, e.g. corresponding with a given protocol established at a given user site (e.g. for a particular physician). In turn, such protocol may provide for the selection of a given one of a plurality of different anti-shivering medicament options (e.g. via an interactive menu).

[0046] In turn, for a selected option, the processor **20** may be operative to provide treatment-dosage (e.g. amount) and frequency-of-dosage information to a user at user interface **30**. Such information may be provided so as to take into account specific data inputted by a user at a user interface **30** for a given procedure, including for example, patient-specific information (e.g. age, weight, sex etc.), and patient procedure-specific information (e.g. thermotherapy pursuant to stroke, thermotherapy pursuant to head trauma, etc.). Additionally and/or alternatively, the information comprising the output **22** may be based, at least in part, upon a magnitude of the measured patient response R reflected by monitoring signal **12**. For example, a magnitude measure may be obtained from the signal **12** and compared with pre-established reference data to assess how much and/or how often a given anti-shivering medicament may be appropriate for administration.

[0047] As illustrated in Fig. 1, processor **20** may further comprise a response module **26** comprising algorithms and/or data for processing the monitoring signal **12** on an ongoing basis, e.g. after initiation of patient shivering response actions by a user (e.g. administration of an anti-shivering medicament), to assess the effectiveness of such actions, wherein such assessment may then be automatically employed in the generation of subsequent output **22**. To yield such functionality, user interface **30** may be employable to receive user input regarding the patient shivering response actions taken by a user, e.g. the identification of the type(s), dosage amount(s) and time(s) of administration of one or more anti-shivering medicament(s). Such input may be store and/or otherwise employed by response module **26** in completing the above-noted assessment. By way of example, the above-noted assessments may include an algorithmic assessment as to the degree of patient shivering reduction and/or the duration of shivering reduction and/or the degree of shivering reduction on a time-scale basis associated with a given anti-shivering medicament administration procedure (e.g. collectively "trend data"). In turn, the response module **26** may be provided to interface with treatment module **24** to provide information in output **22** regarding potential further treatment action on an ongoing basis during a given patient cooling procedure. Such ongoing treatment information may be provided to a user through user interface **30**, wherein such further information is based in part on the trend data assessment.

[0048] In addition to the above-described functionalities, the processor **20** may be further adapted for providing an input signal **28** to the cooling system **50**. Such input signal **28** may employ with a patient temperature sensor **52** output signal **54** to establish a degree of cooling and/or rate of cooling of the given patient P. For example, based upon a measured magnitude of patient response R, a cooling rate may be increased (e.g. when no shivering is detected and more rapid cooling is therapeutically desired) or decreased (e.g. when an undesirably high degree of shivering is detected and therapeutic rapid cooling is realizable at a lower cooling rate).

[0049] Reference is now made to Fig. 2, which illustrates one of embodiment of a method comprising the present invention. Initially, pursuant to a given patient treatment condition, e.g. a stroke, serious head trauma or other like event, a patient cooling procedure may be initiated, pursuant to which a patient is as rapidly cooled to reduce risk of neurological damage, step **102**. In conjunction with the patient cooling procedure, the method may provide for monitoring a physiological response of a patient to a change in the patient's temperature, step **104**. More particularly, the monitoring may include the step of selective interconnection of a non-invasive monitoring device to a patient. In one approach, one or more interconnectable/disconnectable monitoring device(s) may be fixedly positioned to a patient to measure patient motion. For example, patient shivering response may be monitored, via attachment of an accelerometer to a patient's jaw (e.g. masseter region) and/or via attachment of an accelerometer to a patient's chest (e.g. pectoral region) and/or via attachment of an accelerometer to a patient's arm (e.g. bicep region) and/or via attachment of an accelerometer to a patient's leg (e.g. quadricep region), wherein one or a plurality of accelerometers are utilized to provide one or a corresponding plurality of accelerometer output signal(s) employable to assess the magnitude and/or stage of shivering and provide an output indication of at least one measure of the of the patient shivering response to cooling.

[0050] In other approaches that correlate shivering to a monitored parameter, a blood flow monitoring device may be attached to a patient to measure a degree of vasoconstriction reflective of a degree of shivering (e.g. by measuring relative blood flow at a fingertip and at a corresponding forearm location). In an additional approach, the monitoring device may comprise one or more electromyography (EMG) surface sensors for monitoring muscular electrical activity. In yet a further approach, the monitoring device may comprise one or more capnography input sensors for concentration and/or partial pressure of carbon dioxide in patient respiratory gases. In yet another correlative approach, a pulse oximeter sensor may be interconnected to a patient to measure a patient's blood oxygen saturation level, wherein such level may be correlated to a degree of shivering.

[0051] With further reference to Fig. 2, the method may provide for the generation of an output based upon, at

least in part, a monitored patient temperature response, step **106**. By way of example, such output generation may entail the provision of a visual or auditory output. In one embodiment the method may further include processing of a monitoring signal in accordance with the selected one of a plurality of treatment protocols comprising corresponding preset data/algorithms. In one approach, use of a given protocol may provide for user selection of a given anti-shivering medicament or combination(s) thereof, as well as a corresponding output of information relating to dosage and/or frequency information for the selected medicament(s).

[0052] Pursuant to the generation of an output based upon a monitored patient response, the method may encompass use of the output to control a patient shivering response, step **108**. For example, information regarding dosage and/or frequency of a given anti-shivering medicament may be employed by a user in conjunction with the actual administration of the medicament.

[0053] As illustrated by Fig. 2, the steps of monitoring **104**, generating **106** and/or using **108** may be repeated on an ongoing basis during a given thermotherapy procedure, wherein as part of the monitoring step, the patient's response to prior actions taken to control shivering may be assessed (e.g. via trend data assessment) and the output provided in step **108** may take into account the results of such assessment.

[0054] As further illustrated in Fig. 2, output may be provided in relation to the generation step **106** that may be utilized in conjunction with controlling a degree of cooling provided by a cooling system, step **110**. By way of example, in the generating step **106** an input signal may be provided to a cooling system. Such input signal may be utilized by the cooling system to increase, decrease or maintain a rate of patient cooling.

[0055] Referring now to Figs. 4 and 5, a further embodiment of the present invention will be described. As shown, a patient P may be cooled utilizing a cooling system comprising contact pads **200** and a control unit **202** that circulates cooled fluid via supply line(s) **204** and return line(s) **206** though the contact pads **200** (e.g. under negative pressure). In this embodiment, the control unit **202** may further comprise a transceiver **210** for transmitting/receiving wireless signals to/from a motion sensor monitoring device **220a** interconnected to the chin of a patient P.

[0056] By way of example, and with reference to Fig. 4, the motion sensor **220a** may include an accelerometer housed within a housing **222** having an adhesive backing **224** and removable liner **226** initially provided therewith. To initiate patient use, the liner **226** may be selectively removed, wherein the adhesive backing **224** may be mounted to a jaw of a patient. In one approach, an on-board battery may be housed in housing **222**, e.g. for powering the accelerometer and an on-board transmitter for transmitting a monitoring signal **214** indicative of a magnitude of motion of the patient's chin.

[0057] In another approach, the transceiver **210** pro-

vided with the control unit **202** may be adapted to transmit a query/power signal **212** to the motion sensor **220a**. In turn, the motion sensor **220a** may transmit a monitoring signal **214** to the transceiver **210** which is indicative of a degree of motion of the patient's chin. More particularly, the motion sensor **220a** may comprise a transceiver and rectifier arrangement for receiving a query/power signal **212**, transducing electrical energy therefrom, and using the energy to generate and transmit the monitoring signal **214**.

[0058] As may be appreciated, a plurality of motion sensors **220** may be employed. For example, motion sensors **220b** and **220c**, of like configuration to motion sensor **220a**, may be selectively interconnected to different body regions (e.g. an arm and leg of a patient). In such an arrangement, each of the sensors **220a**, **220b** and **220c** may provide a wireless monitoring signal **214**.

[0059] The monitoring signal(s) **214** may be processed at the control unit **202** in accordance with the described functionalities to provide an output (e.g. a visual or auditory output) at a user interface **230**. As previously noted, the output may provide an indication of a magnitude or stage of patient shivering. Additionally or alternatively, such output may provide anti-shivering medicament related information, e.g. dosage and/or frequency information for use by medical personnel in the administration of an anti-shivering medicament. As further reflected by Fig. 4, control unit **202** may include a user input **240** (e.g. a keyboard, touch-screen or point-and-click interface) for user selection of a given anti-shivering treatment protocol, for inputting instructions and/or data regarding the type, amount and timing of medicament administration, and/or for inputting patient-specific information. In conjunction with control operations, the control unit **202** may be further provided for use in controlling patient cooling in accordance with a pre-established protocol(s), e.g. as taught by U.S. Patent Nos. 6,620,187, 6,692,518, 6,818,012, and 6,827,728, the entirety of which are hereby incorporated by reference.

[0060] As further reflected by Fig. 3, and as an option to control unit **202**, a handheld unit **250** may be provided that includes a transceiver **252** for use in transmitting signals **254** and receiving signals **256** to/from the monitoring device **220**. As illustrated, the hand held unit may **250** comprise a user output **258** for providing treatment related information.

[0061] In further relation to the above-described functionality, reference is now made to Figs. 5 and 6 which illustrate an embodiment of a user interface **230** that may be provided at control unit **202**. As illustrated in Fig. 5, the user interface **230** may be provided to allow a user to selectively access various interactive screens for use in conjunction with a given patient therapy in which control unit **202** may be employed to circulate cooled and/or warmed fluid through contact pads **200** to adjust a patient's temperature in accordance with a predetermined and/or otherwise controllable protocol.

[0062] As shown in Fig. 5, an interactive screen **300**

may be provided at user interface **230** which includes a graphic display portion **310** that graphically illustrates temperature-related data in a first region **312** as a function of time, and that further illustrates patient motion data, e.g. shivering data, as a function of time in a second region **314**. The first region **312** may present a first plot **320** of a target patient temperature level as a function of time, e.g. a predetermined patient temperature adjustment rate plot reflecting a desired patient temperature to be reached by controlling the temperature of the circulated fluid. Further, a second plot **322** of a measured patient temperature as a function of time may be presented. Additionally, a third plot **324** of a measured temperature of the fluid circulated by control unit **202** though contact pads **200** may be provided.

[0063] In relation to the target patient temperature plot **320**, the control unit **202** may include an on-board processor pre-programmed or otherwise programmable to facilitate automated control over patient temperature adjustment therapy. In the later regard, the control unit **202** may be provided with a pre-programmed control module to facilitate automated control over the temperature of the circulated fluid so as to cool a patient in accordance with programmable protocol data during a first phase of treatment, and to re-warm a patient in accordance with another programmable protocol during a second phase of treatment.

[0064] As shown by Fig. 5, the second region **314** of the screen **300** may be provided to visually display patient motion data in relation to a predetermined magnitude scale. By way of example, a plurality of predetermined levels of patient motion, or degrees of shivering, may be graphically presented as a function of time. In the illustrated example, four levels of detected patient motion may be provided to a user, wherein no visual indication is provided for a low, or "zero" level of motion, and wherein increasing level of motions may be graphically presented by one, two or three stacked "box" indicators.

[0065] As may be appreciated, by visually monitoring the magnitude of shivering response displayed in the second region **314** of the screen **300**, medical personnel may assess the need and/or desirability for taking responsive action. For example, such responsive action may include the administration of anti-shivering medicaments and/or the application of surface warming therapy to selected patient body regions and/or a modification to the patient cooling/warming protocol discussed hereinabove (e.g. decreasing a target patient cooling rate and/or a increasing targeted temperature for patient cooling).

[0066] As reflected by Fig. 6, screen **300** may also be employable in conjunction with the operation of one or a plurality of motion sensors employable to provide a monitoring signal. By way of example, such motion sensors may be in the form of motion sensors **220a**, **220b** and **220c** discussed hereinabove in relation to Fig. 3. As shown in Fig. 6, interactive screen **300** may be provided to visually facilitate the establishment of wireless communications with each of the sensors, to visually indicate

the communication signal strength for each of the motion sensors **220a**, **220b** and **220c**, to visually indicate a battery power level at each of the motion sensors **220a**, **220b** and **220c** (e.g. as reflected by a portion of corresponding wireless monitoring signals), and/or to visually indicate a detected shivering magnitude corresponding with each of the sensors **220a**, **220b** and **220c**.

[0067] Reference is now made to Figs. 7A, 7B and 7C illustrating another embodiment of a motion sensor **400**. As shown in Fig. 7A, the sensor **400** may include a base pad **402** initially provided with a removable liner **404** overlying an adhesive bottom surface of the base pad **402**. As may be appreciated, the liner **404** may be selectively removed prior to adhesive interconnection of the motion sensor **400** to a patient. The motion sensor **400** further includes a housing portion **408** that houses a sealed sensor assembly **410** which is shown in Fig. 7B. As illustrated in Fig. 7C, of the sensor assembly **410** may include an accelerometer module **412** that is located between opposing circuit elements mounted on opposing, inside surface(s) of a wrap-around circuit board **414**. In the illustrated embodiment, a transceiver device **416**, e.g. an RF antenna, may be patterned on a stub portion **418** of the circuit board 414 for wireless transception of monitoring signals and power signals. In the later regard, circuit correspondingly located on circuit board **414** may include a rectifier and/or battery for powering the sensor operations. In other embodiments, the patterned antenna **416** may be replaced by a chip transceiver mounted on the circuit board 414.

[0068] Referring again now to Fig. 1, and as noted above, a processor or logic circuit **20** may be provided to utilize one or a plurality of monitoring signal(s) **12** provided by one or a plurality of monitoring device(s) **10** to yield an output **22**. In that regard, and by way of example, a processor **20** may be preprogrammed for time domain and/or frequency domain processing of a monitoring signal provided by a monitoring device **10** that includes a three-dimensional accelerometer as a motion sensor, and for providing a monitoring signal indicative of acceleration in each of three-dimensions as a function of time. In this regard, it may be desirable for the accelerometer to sample at about twice the highest frequency component of interest (e.g. at least about 40Hz). Reference is now made to Figs. 8A-8C which illustrate a frequency domain processing embodiment.

[0069] As shown in Fig. 8A, a monitoring signal **12** may be provided as a sensor input comprising a stream of sequential data sample sets, wherein each data set comprises data corresponding with a measured magnitude related to acceleration in each of the three dimensions, x, y and z, (e.g. a measured voltage magnitude for each of three-dimensions). In turn, overlapping frames of data sets may be processed, wherein each frame *m* comprises a plurality of data sets *n* and wherein sequential ones of such frames at least partially overlap and are at least partially different, (e.g. the "hop" reference in Fig. 8A). In one embodiment, each frame may comprise about 512

data sets.

[0070] As shown in Fig. 8B, for each frame *m* of *n* data sets, the corresponding data sets may be de-interleaved to yield three data portions corresponding with each of the three dimensions, e.g. *x*(*n*), *y*(*n*) and *z*(*n*). Then, the three data portions may be windowed, e.g. utilizing a Kaiser windowing approach. The windowed data may be further processed according to a Fourier transform function to obtain frequency domain data. In turn, a square of the modulus of the frequency domain data may be determined for each of the three-dimensional data sets corresponding with a given frame, and the resultant values may summed to generate a spectral output for each frame. In turn, the spectral output for a plurality of frames of data may be analyzed on an ongoing basis to detect and assess patient motion.

[0071] In this regard, reference is now made to Fig. 8C which illustrates exemplary spectral data corresponding with multiple frames of data (e.g. about 130 frames). In particular, for each frame of data a corresponding spectral distribution across a predetermined frequency range of about 0Hz to about 20Hz is shown, wherein the magnitude corresponding with a given frequency is reflected by the number or concentration of data points. In relation to the illustrated example, the spectral data may be analyzed in relation to a plurality of frequency bands, e.g. a first band of about 0Hz to 5.5 Hz, a second band of about 5.5Hz to 12.5 Hz, a third band of about 12.5Hz to 16Hz, and optionally a fourth band of about 16Hz to 20Hz.

[0072] Of particular interest is the spectral data corresponding with the second frequency band of about 5.5Hz to about 12.5Hz. In this regard, it has been recognized that shivering is most frequently reflected by a patient motion component that is centered at about 9.5Hz. In the example of Fig. 8C, for the second frequency band, it may be seen that patient shivering may be indicated in relation to the spectral data corresponding with data frames beginning at about frame "40", wherein increasing degrees of shivering are reflected from about frame "110" to frame "120". Non-shivering motion may be reflected by the spectral data corresponding with the data frames preceding frame "40".

[0073] As may be appreciated from the example shown in Fig. 8C, spectral data corresponding with a plurality of successive data frames may be statistically analyzed and processed on an ongoing basis in relation to each of a plurality frequency of bands. In particular, and with reference to Fig. 8C, for a given frame or set of frames, the spectral data points within each frequency band may be collected into a corresponding data set. In turn, for each of the data sets corresponding with each frequency band, a mean square energy value, a peak energy value and a crest factor value may be determined, as shown in Fig. 8D. Thereafter, the mean square energy values, peak energy values, crest factor values for each of the frequency bands may be compared to one another and/or with corresponding values in previous frame sets to detect a predetermined magnitude or degree of motion cor-

responding with patient shivering.

[0074] By way of example, in one approach the mean square energy values and crest factor values for two or more frequency bands may be compared (e.g. a "low" frequency band of about 0Hz to 5.5Hz, a "middle" frequency band of about 5.5Hz to 12.5Hz, and an "upper" frequency band of about 12.5Hz to 16Hz), wherein a calculated mean square energy value of the lower band which is greater than or equal to a calculated mean square energy value for the upper band, together with a crest factor value for all three bands that is less than a predetermined value (e.g. a relatively low value), may indicate the absence of or a relatively low level of patient motion. Further, a rise in the mean square energy value and crest factor value for each of the bands may indicate patient motion. And, a rise in the mean square energy value for the middle band (e.g. encompassing the 9.5Hz level typically related to shivering) relative to the low and high bands, together with a decrease in the crest factor value for the middle band, may indicate the presence and/or a degree of patient shivering.

[0075] As noted above, a monitoring signal **12** may also be processed via time domain processing. In one embodiment shown in Figs. 9A-9C, a monitoring signal, or sensor input, three-dimensional accelerometer output data may be filtered and processed to yield power values associated with a predetermined plurality of frequency bands. In turn, the power values may be analyzed to obtain an indication of a magnitude degree and/or stage of shivering. By way of example, and as shown in Fig. 9A, the monitoring signal may comprise sets of three-dimensional data that may be filtered to block, or remove, DC frequency components (e.g. to reduce or remove gravitational influences). In turn, a square of a modulus value corresponding with the three-dimensional data sets may be computed and summed for each and/or a plurality of frames of data sets. Such processing may be conducted without frequency filtering to obtain a first power value. Further, such processing may be conducted after applying a high-pass filter (e.g. to filter out or remove frequency components in a lower band (of about 5.5Hz or less)) to obtain a second power value, and after applying both a high-pass filter and a low-pass filter (e.g. filter out or remove frequency components above about 12.5Hz) to obtain a third power value. The second and third power values may be subtracted from the first power value to obtain a power value associated with a lower, or "below-shiver", frequency band (e.g. about 0Hz to 5.5Hz). Further, the third power value may be subtracted from the second value to obtain a power value associated with a higher, or "above-shiver", frequency band (e.g. above about 12.5Hz). Finally, the third power value may be understood to be associated with a middle frequency band, or "shiver band", (e.g. about 5.5Hz to 12.5Hz).

[0076] As further reflected by Fig. 9A after high-pass and low-pass filtering of the monitoring signal, the filtered data sets may be further processed via a prediction error filter (PEF) to yield a prediction error power value. In this

regard, an adaptive filter (e.g. a first-order least mean squares adaptive filter) may be applied, as reflected by Fig. 9B. Further, an output of the predictive error filter may be employed in conjunction with a single value decomposition (SID) spatial analysis to obtain a condition ratio value and minor axis of motion value, as reflected by Fig. 9B.

[0077] In turn, the above-noted values may be utilized to assess shivering. For example, in one approach the below-shiver band, above-shiver band and shiver-band power values may be compared, wherein a below-shiver band power value that is greater than or equal to that of the other bands, together with a condition ratio that is less than a predetermined value (e.g. a relatively low value), may indicate the absence of or a relatively low level of patient motion. Further, a rise in the shiver-band power value, a rise in the condition ratio, and a rise in a shiver-band power value-to-prediction error power value ratio, (e.g. shiver-band power value/prediction error power value) may combinatively indicate patient motion. Further, a rise in the shiver-band power value, coupled with a decrease in the condition ratio and a decrease in the shiver-band power value-to-prediction error power value ratio, may indicate the presence and/or a degree of patient shivering.

[0078] Additional embodiments to those described above will be apparent. For example, in relation to the motion sensor **400** of Fig. 7A-7C, the sensor **400** may be modified to include one or more output devices for providing an output at sensor **400** indicative of a detected magnitude or level of detected patient shivering, e.g. one or more LED (i.e. light emitting diode) interconnected to the sensor **400** for co-movement therewith (e.g. wherein illumination of an LED indicates detected shivering above a predetermined level and/or wherein illumination of different ones or sets of a plurality of LED's may be employed to indicate corresponding degrees of detected shivering). In turn, an on-board processor for processing the monitoring signal, and an on-board power source (e.g. a battery) and/or an on-board wireless energy receiving device (e.g. an RF signal receiver and rectifier) may be included to power the components.

[0079] The embodiment descriptions provided above are for purposes illustration and are not intended to limit the scope of the present invention. Additions and modifications will be apparent to those skilled in the art.

Clauses:

[0080]

1. A medical apparatus, comprising:

- a monitoring device for monitoring patient shivering and for providing a monitoring signal responsive thereto;
- at least one of an energy storage device and a wireless energy conversion device, intercon-

ected to said monitoring device for co-movement therewith, for powering said monitoring device; and,
 an output device for providing an output to a user responsive to said monitoring signal and indicative of at least one measure of said shivering.

2. A medical apparatus as recited in Clause 1, wherein said output device provides at least one of a visual output and an auditory output indicative of said at least one measure of said shivering.

3. A medical apparatus as recited in Clause 2, wherein said monitoring device is selectively interconnectable to and disconnectable from a patient, and wherein said monitoring device is maintainable in fixed relation to a patient upon interconnection.

4. A medical apparatus as recited in Clause 3, wherein said output device is one of interconnected and interconnectable to said monitor device for co-movement therewith.

5. A medical apparatus as recited in Clause 1, wherein said monitoring device comprises:
 a motion sensor selectively interconnectable to a patient.

6. A medical apparatus as recited in Clause 5, wherein said motion sensor comprises:
 an accelerometer.

7. A medical apparatus as recited in Clause 5, wherein said motion sensor comprises:

a three-dimensional accelerometer, wherein said monitoring signal comprises three-dimensional acceleration data.

8. A medical apparatus as recited in Clause 1, further comprising:

a processor for processing said monitoring signal to provide an output control signal for use by said output device in providing said output to a user.

9. A medical apparatus as recited in Clause 8, further comprising:

a plurality of motion sensors for separately monitoring motion of a patient and providing separate monitoring signals responsive thereto; and,
 at least one of an energy storage device and a wireless energy conversion device, each interconnected to a different corresponding, one of said plurality of motion sensors for co-movement therewith and for powering said corresponding one of said plurality of motion sensors, wherein said processor is adapted to process said separate monitoring signals to provide said output control signal.

5

10

15

20

25

30

35

40

45

50

55

10. A method for use in monitoring patient shivering, comprising:

monitoring shivering of a patient at monitoring device to provide a monitoring signal responsive thereto;
 powering said monitoring device by at least one of an energy storage device and a wireless energy conversion device interconnected to said monitoring device for co-movement therewith;
 and,
 providing an output to a user responsive to said monitoring signal and indicative of at least one measure of said patient shivering.

11. A method as recited in Clause 10, wherein said providing step comprises:

outputting at least one of a visual output and an auditory output indicative of said at least one measure of said patient shivering.

12. A method as recited in Clause 10, further comprising:

interconnecting said monitoring device to a patient prior to a therapy procedure, wherein said monitoring device is maintainable in fixed relation to the patient upon said interconnection;
 and,
 disconnecting said monitoring device from said patient after said therapy procedure.

13. A method as recited in Clause 12, wherein said interconnecting step comprises:

adhesively attaching said monitoring device to a selected location on a patient.

14. A method as recited in Clause 10, further comprising:

transmitting said monitoring signal as a wireless signal; and,
 receiving said wireless monitoring signal for use in said providing step.

15. A method as recited in Clause 14, wherein said powering step comprises:

converting a wireless power signal to an electrical signal utilizing a wireless energy conversion device, wherein said electrical signal provides power to said monitoring device and to a transmitter for use in said transmitting step.

16. A method as recited in Clause 15, wherein said wireless energy conversion device and said transmitter are interconnected to said monitoring device for co-movement therewith.

17. A method as recited in Clause 10, wherein said monitoring step comprises:

utilizing a motion sensor interconnected to said patient to provide said monitoring signal indicative of

motion of said patient.

18. A method as recited in Clause 17, further comprising:

processing motion data comprising said monitoring signal utilizing frequency domain processing.

19. A method as recited in Clause_18, wherein said motion data includes three-dimensional accelerometer output data.

20. A method as recited in Clause 19, wherein said processing step includes:

windowing said three-dimensional motion data; transforming the windowed three-dimensional motion data to frequency domain data; and, performing a statistical analysis of the frequency domain data in relation to a plurality of predetermined frequency bands to monitor one of a relative magnitude, degree and stage of patient shivering.

21. A medical apparatus, comprising:

a monitoring device for monitoring at least one physiological response of a patient to an change in temperature of the patient to provide a monitoring signal responsive thereto; a processor for processing said monitoring signal to provide an output employable for use in controlling a patient shivering response to said patient temperature change.

22. A medical apparatus as recited in Clause 21, wherein said monitoring device is non-invasive.

23. A medical apparatus as recited in Clause 22, wherein said monitoring device is selectively interconnectable and disconnectable from a patient, and wherein said monitoring device is maintainable in fixed relation to a patient upon interconnection.

24. A medical apparatus as recited in Clause 23, wherein said monitoring device is selected from a group consisting of:

a monitoring device for monitoring blood oxygen saturation of a patient; a monitoring device for monitoring vasoconstriction of a patient; a monitoring device for surface monitoring of muscular electrical activity of a patient; a monitoring device for monitoring at least one carbon dioxide parameter of a respiratory gas of a patient; and a monitoring device for monitoring motion of a patient.

25. A medical apparatus as recited in Clause 21, wherein said monitoring device comprises: a motion sensor selectively interconnectable to a patient.

5

10

15

20

25

30

35

40

45

50

55

26. A medical apparatus as recited in Clause 25, wherein said motion sensor comprises: an accelerometer.

27. A medical apparatus as recited in Clause 21, wherein said output comprises:

information employable for use in administering at least one anti-shivering medicament to a patient.

28. A medical as recited in Clause 27, wherein said information comprises at least one of anti-shivering medicament dosage information and anti-shivering medicament frequency of dosage information.

29. A medical apparatus as recited in Clause 27, wherein said information is at least in part, utilizing a magnitude of said monitored responses as reflected by said monitoring signal.

30. A medical apparatus as recited in Clause 27, wherein said information is generated, at least in part, utilizing patient-specific data inputted by a user.

31. A medical apparatus as recited in Clause 27, wherein said information is generated, at least in part, in accordance with a user-established protocol.

32. A medical apparatus as recited in Clause 27, wherein said processor is operable to process said monitoring signal to assess patient shivering response to at least one administration of said at least one anti-shivering medicament to provide updated information employable in a subsequent administration of said at one anti-shivering medicament.

33. A medical apparatus as recited in Clause 27, further comprising:

a user interface for providing said output information in at least one of said audible form and visual form.

34. A medical apparatus as recited in Clause 33, wherein said user interface is adapted to receive user input for use by said processor in generating said information.

35. A medical apparatus as recited in Clause 21, wherein said monitoring device is adaptable to provide said monitoring signal as a wireless signal.

36. A medical apparatus as recited in Clause 35, further comprising:

a receiver, operatively interconnected to said processor, for receiving said wireless monitoring signal and providing said monitoring signal to said processor.

37. A medical apparatus as recited in Clause 35, further comprising:

a transducer, operatively connected to said processor, for transmitting signals to and receiving signals from said monitoring devise; and wherein said monitoring devise is operable to transduce electrical energy from said signals transmitted by said transceiver and to utilize said electrical energy in the processor of said monitoring signal.

38. A medical apparatus as recited in Clause 35,

wherein said monitoring device comprises:
an on-board power source.

39. A medical apparatus as recited in Clause 21,
wherein said processor is further operable to use
said monitoring signal in the generation of an input
signal to a temperature control system for controlling
a temperature of a patient.

40. A method for use in controlling a shivering response
of a patient during patient cooling, comprising:

- monitoring at least one physiological response
of a patient to a change in temperature of the
patient; and
- generating an automated output based at least
in part on the monitored response for use in controlling
a patient's shivering response to the patient's
temperature change.

41. A method as recited in Clause 40, wherein said
monitoring step comprises:
at least one of:

- monitoring motion of the patient;
- monitoring vasoconstriction of the patient;
- monitoring muscular electrical activity of a patient;
- monitoring at least one carbon dioxide parameter
of a respiratory gas of a patient; and
- monitoring blood oxygen saturation of the patient.

42. A method as recited in Clause 40, further comprising:
selectively interconnecting a monitoring device in
fixed relation to a patient, wherein said monitoring
device is employable in said monitoring step.

43. A method as recited in Clause 41, wherein said
monitoring device comprises a motion sensor, and
wherein said interconnecting step comprises:
adhesively attaching said motion sensor to a selected
location on a patient.

44. A method as recited in Clause 41, wherein said
output comprises:
information employable for use in administering at
least one anti-shivering medicament to a patient.

45. A method as recited in Clause 44, wherein said
information comprises at least one of dosage information
and frequency information corresponding with an anti-shivering
medicament.

46. A method as recited in Clause 44, further comprising:
administering said at least one anti-shivering medicament
to a patient.

47. A method as recited in Clause 46 further comprising:

- repeating said monitoring and processing steps

at plurality of times; and
utilizing data inputted by a user that corresponds
with said administering step in a subsequently
performed processing step to provide updated
information employable in a subsequent administering
step.

48. A method as recited in Clause 45, wherein said
generating step comprises:

utilizing patient-specific data provided by a user.
49. A method as recited in Clause 48, further comprising:
receiving input at a user interface in completing said
utilizing step.

50. A method as recited in Clause 49, further comprising:
outputting said information to a user in at least one
of a visual form and an audible form.

Claims

1. A system for use in a patient cooling therapy procedure,
comprising:

- a monitoring device for monitoring patient shivering
and for providing a monitoring signal responsive thereto,
wherein the monitoring device is selectively interconnectable
in fixed relation to and disconnectable from a patient;
- a control unit configurable to cool and warm a fluid
circulated through at least one contact pad for thermal
exchange with a patient, including:

at least one processor programmed to:

- control automatically a temperature of the circulated
fluid so as to cool and warm a patient in different
treatment phases in accordance with a predetermined
protocol; and,
- process said monitoring signal to provide an output
signal indicative of a magnitude of patient shivering; and,

a user interface to graphically display, on an ongoing
basis as a function of time during a patient cooling therapy
procedure, each of the following:

- patient motion data, responsive to said output signal,
indicating a magnitude of patient shivering as a function
of time, wherein said patient motion data is displayed
in relation to a predetermined magnitude scale having a
plurality of predetermined levels of patient motion
indicative of increasing degrees of pa-

tient shivering;
 a predetermined patient temperature adjustment rate plot indicating a desired patient temperature to be reached as a function of time;
 a measured patient temperature plot indicating a measured patient temperature as a function of time; and,
 a measured circulated fluid temperature plot indicating a measured temperature of said circulated fluid as a function of time.

- 2. A system as recited in Claim 1, wherein said user interface provides a screen that includes: a graphic display portion that graphically displays said predetermined patient temperature adjustment rate plot, said measured patient temperature plot, and said measured circulated fluid temperature plot in a first region of the graphic display portion, relative to a temperature scale and time scale.
- 3. A system as recited in Claim 2, wherein said graphic display portion graphically displays said patient motion data in a second region of the graphic display portion, relative to said time scale.
- 4. A system as recited in Claim 1, further comprising: at least one of a battery and a wireless energy conversion device, interconnected to said monitoring device for direct co-movement therewith, for powering said monitoring device free from hardwire interconnection with a power source.
- 5. A system as recited in Claim 4, wherein said at least one of a battery and a wireless energy conversion device being one of directly connected to said monitoring device and interconnected to a common support member together with said monitoring device for co-movement therewith.
- 6. A system as recited in Claim 4, further comprising: a transmitter for transmission of a wireless signal corresponding with said monitoring signal, wherein said transmitter comprises an antenna and is interconnected to said monitoring device for co-movement therewith.
- 7. A system as recited in Claim 1, wherein said processor is operable to employ said monitoring signal to generate an input for use in controlling the temperature of the circulated fluid.
- 8. A system as recited in Claim 1, wherein said monitoring device is for monitoring blood oxygen saturation of a patient; one of the following:

monitoring vasoconstriction of a patient;

surface monitoring of muscular electrical activity of a patient;
 monitoring at least one carbon dioxide parameter of a respiratory gas of a patient; and,
 monitoring motion of a patient.

- 9. A system as recited in Claim 1, wherein said monitoring device comprises a motion sensor including: a three-dimensional accelerometer, wherein said monitoring signal comprises three-dimensional acceleration data and comprises a stream of sequential data sets.
- 10. A system as recited in Claim 9, wherein said at least one processor is programmed to: process said monitoring signal utilizing frequency domain processing to provide said output signal, wherein in said process said at least one processor is programmed to process a plurality of frames of said sequential data sets on an ongoing basis to determine spectral data corresponding with each different one of said plurality of frames of said sequential data sets, wherein each frame of said plurality of frames of said sequential data sets comprises a plurality of said sequential data sets, wherein sequential ones of said plurality of said frames of said sequential data sets are partially overlapping and partially non-overlapping, and wherein for said plurality of frames of said sequential data sets the at least one processor is programmed to collect and analyze spectral data sets corresponding with each different one of a plurality of different, predetermined frequency bands to detect said magnitude of patient shivering.
- 11. A system as recited in Claim 10, wherein each of said sequential data sets comprises data corresponding with a measured magnitude related to acceleration in each of said three dimensions.
- 12. A system as recited in Claim 11, wherein for each frame of said plurality of frames said at least one processor is programmed to: de-interleave said frame to obtain three data portions corresponding with each of said three dimensions; window said three data portions; and, transform the three windowed data portions to obtain three corresponding frequency domain data portions.
- 13. A system as recited in Claim 12, wherein for each frame of said plurality of frames said at least one processor is programmed to: utilize the three corresponding frequency domain data portions to obtain a corresponding spectral output.
- 14. A system as recited in Claim 10, wherein said plu-

rality of different, predetermined frequency bands in-
 cludes at least a predetermined first frequency band
 and a different, predetermined second frequency
 band, wherein only one of said predetermined first
 frequency band and said predetermined second fre- 5
 quency band includes a frequency of 9.5 Hz.

15. A system as recited in Claim 10, wherein for each
 frame of said plurality of frames the at least one pro- 10
 cessor is programmed to:

analyze the spectral data sets corresponding
 with each of said plurality of different, predeter- 15
 mined frequency bands to determine a mean
 square energy value, a peak energy value and
 a crest factor; and,
 compare the mean square energy values, peak
 energy values, and crest factor values for each
 of the plurality of different, predetermined fre- 20
 quency bands to one another or with previously
 determined, corresponding values to detect a
 degree of motion corresponding with patient
 shivering.

25

30

35

40

45

50

55

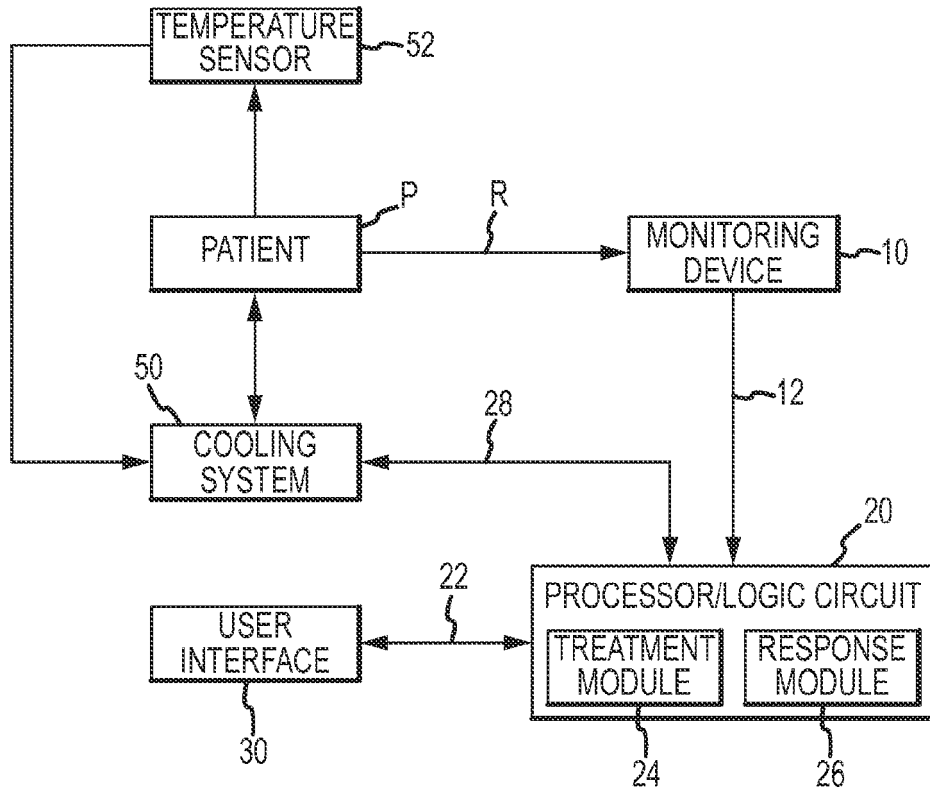

FIG. 1

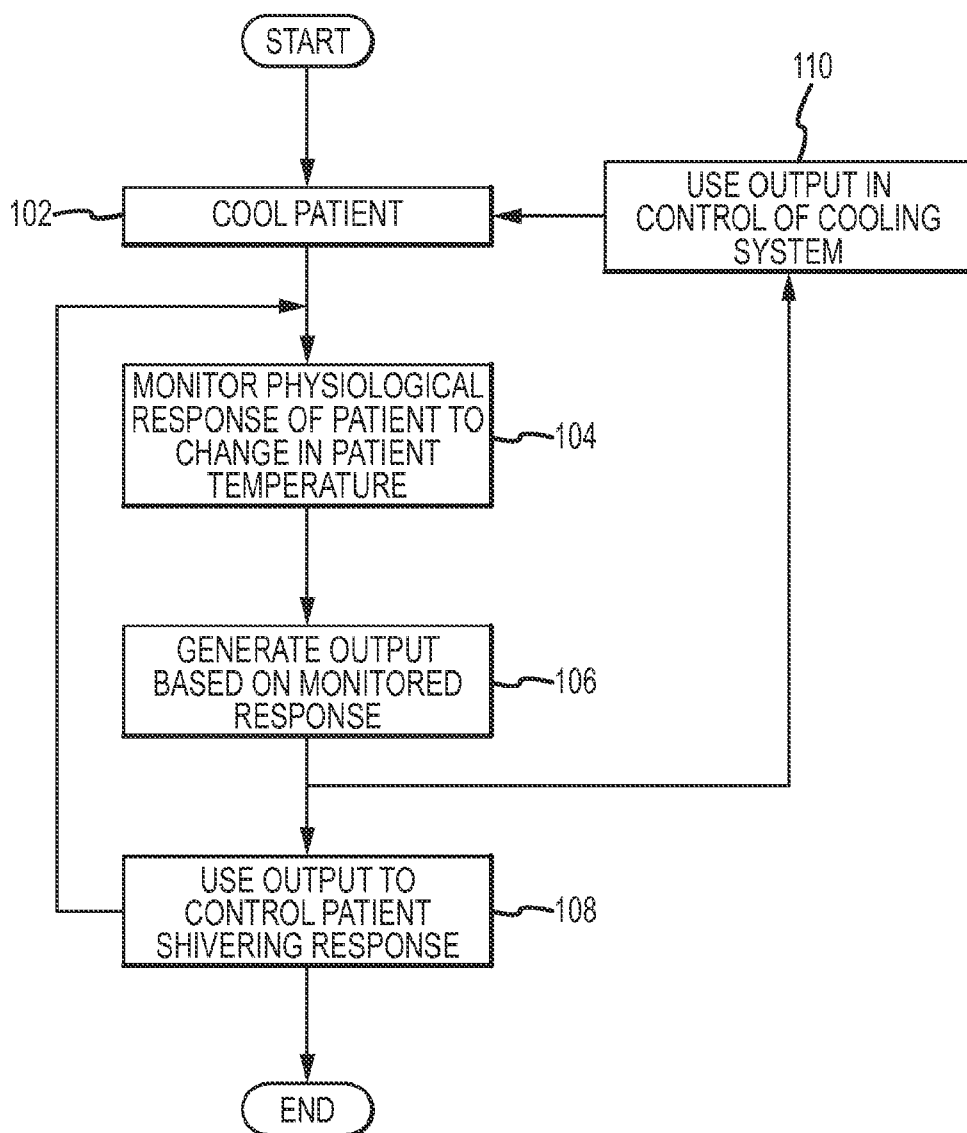

FIG.2

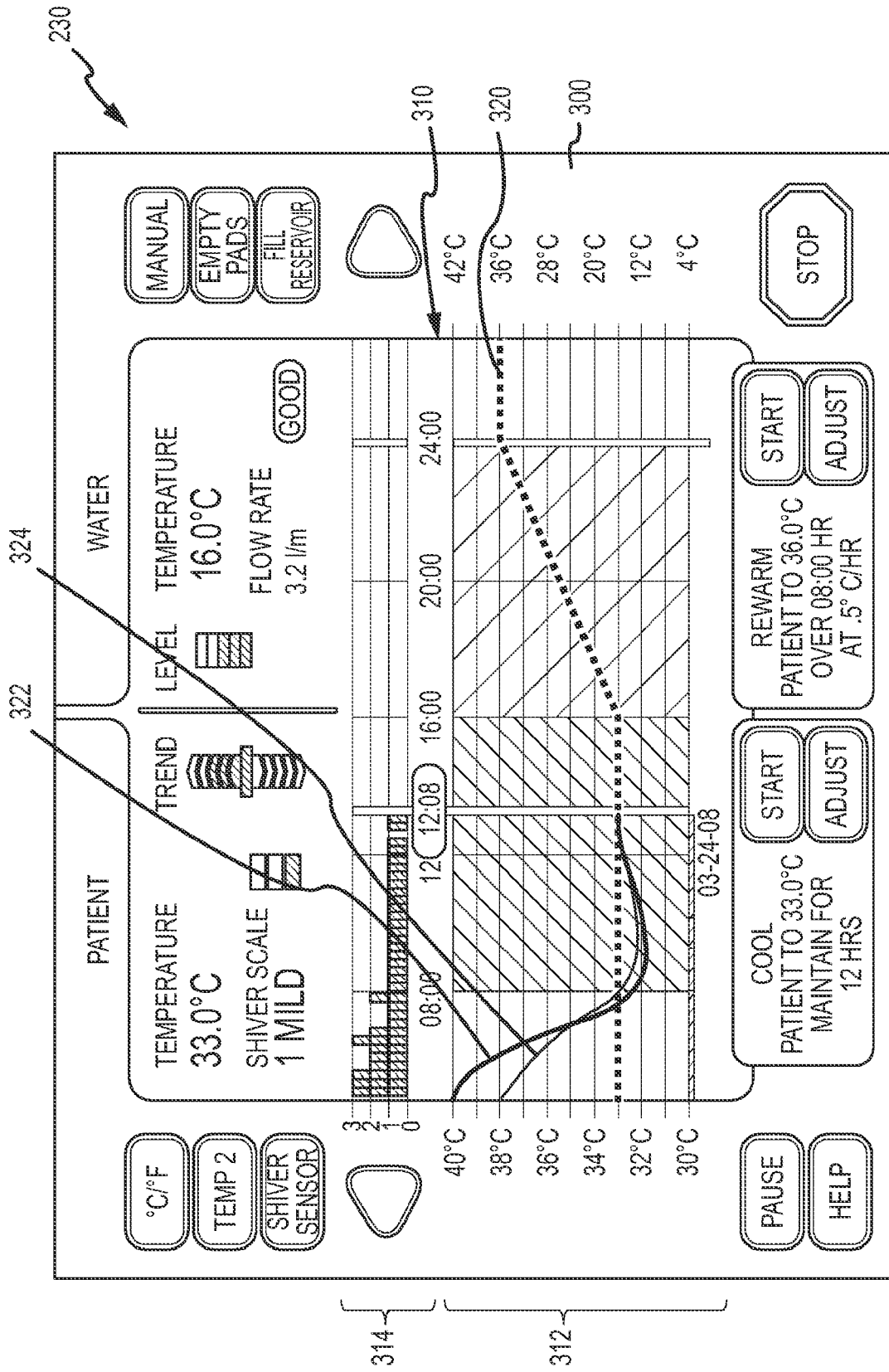

FIG.5

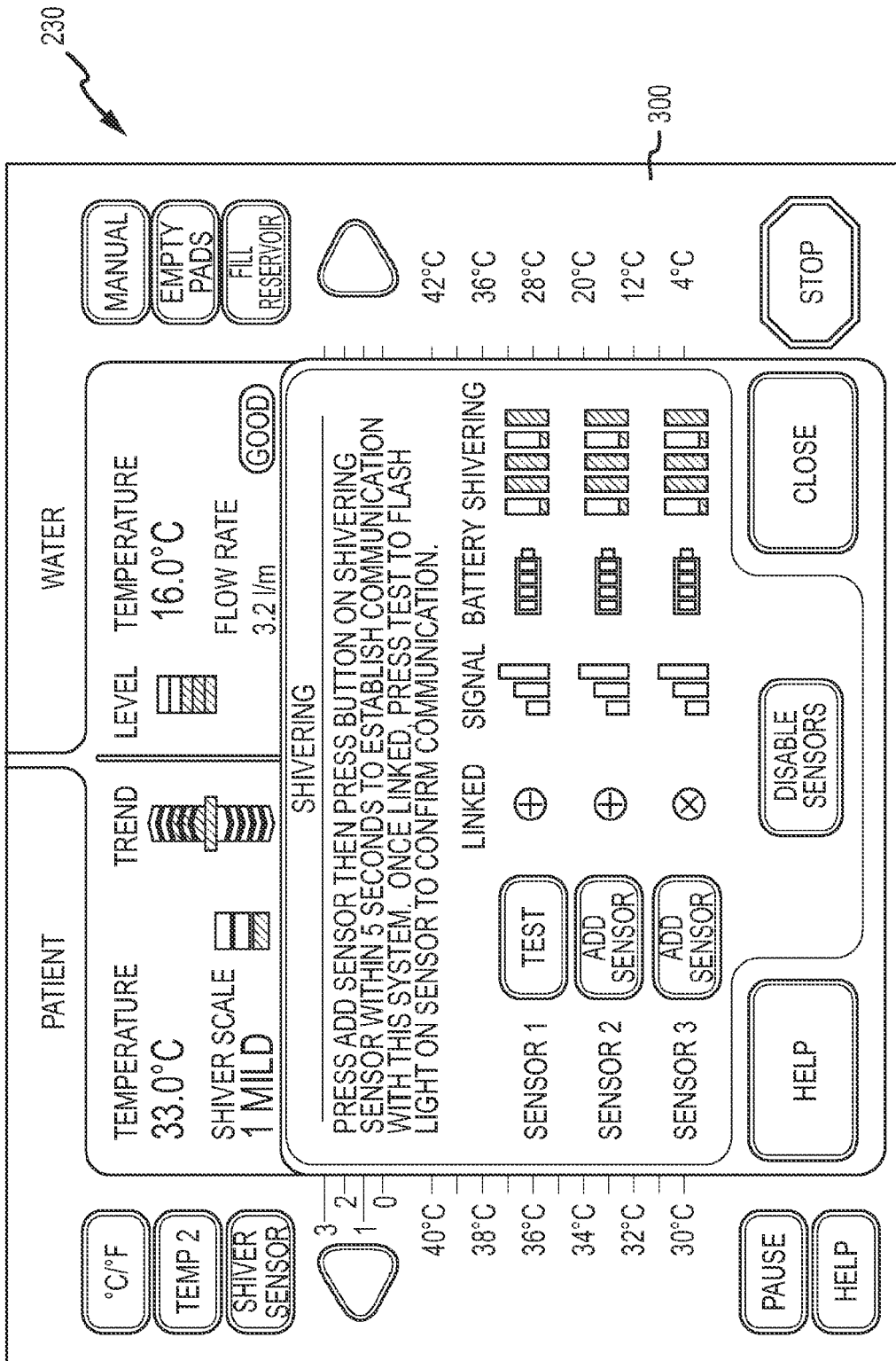

FIG. 6

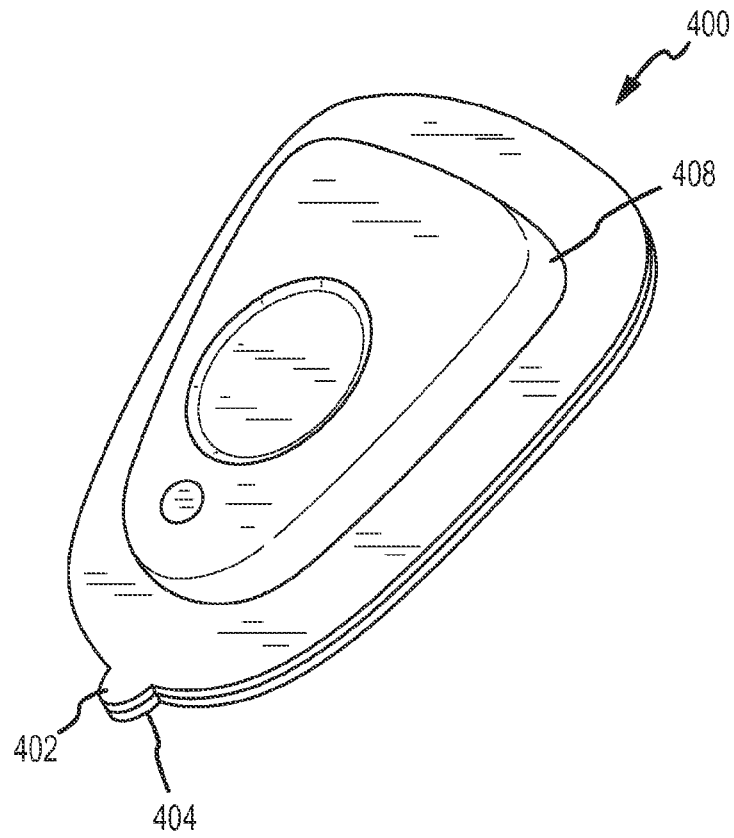

FIG.7A

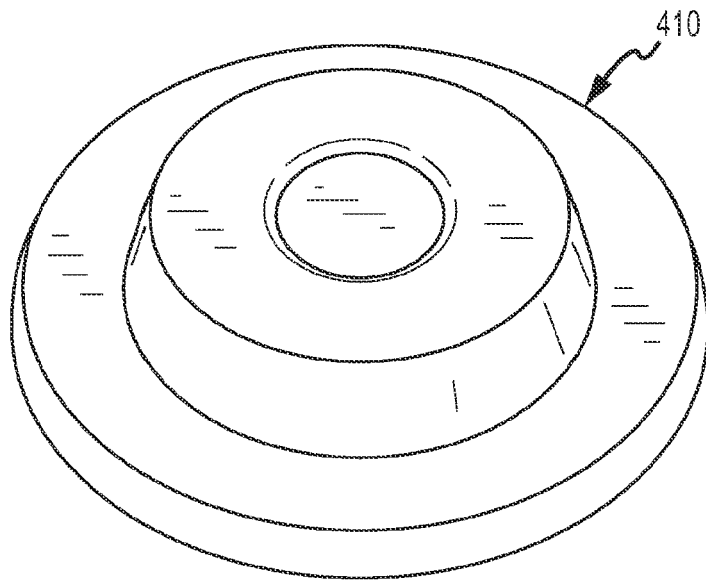

FIG.7B

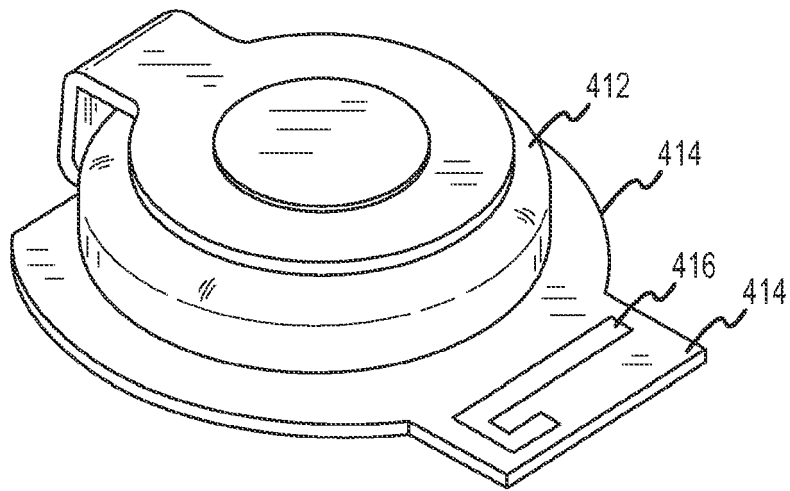

FIG.7C

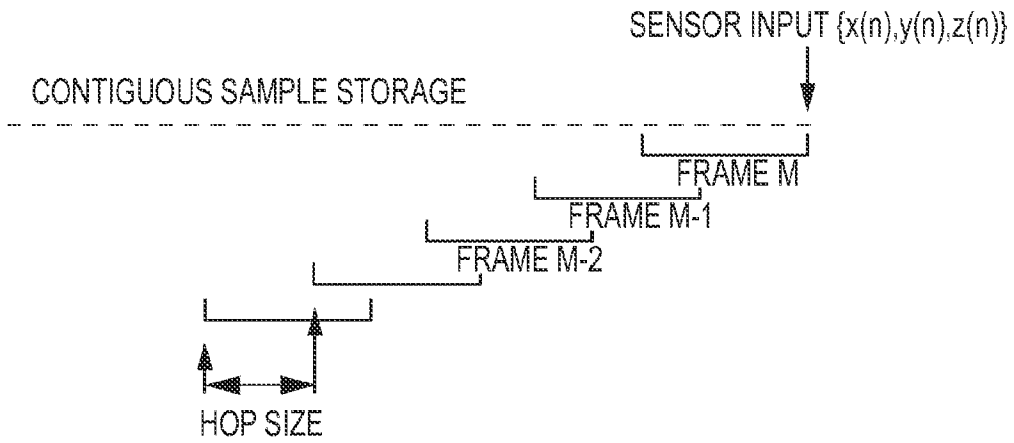

FIG.8A

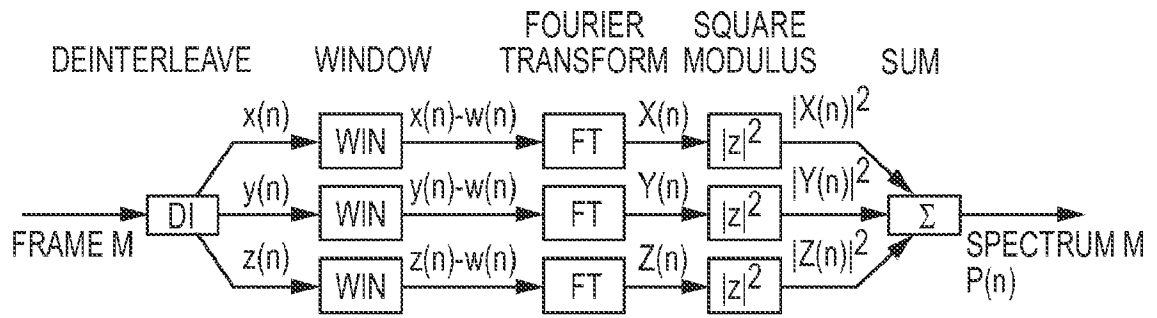

FIG.8B

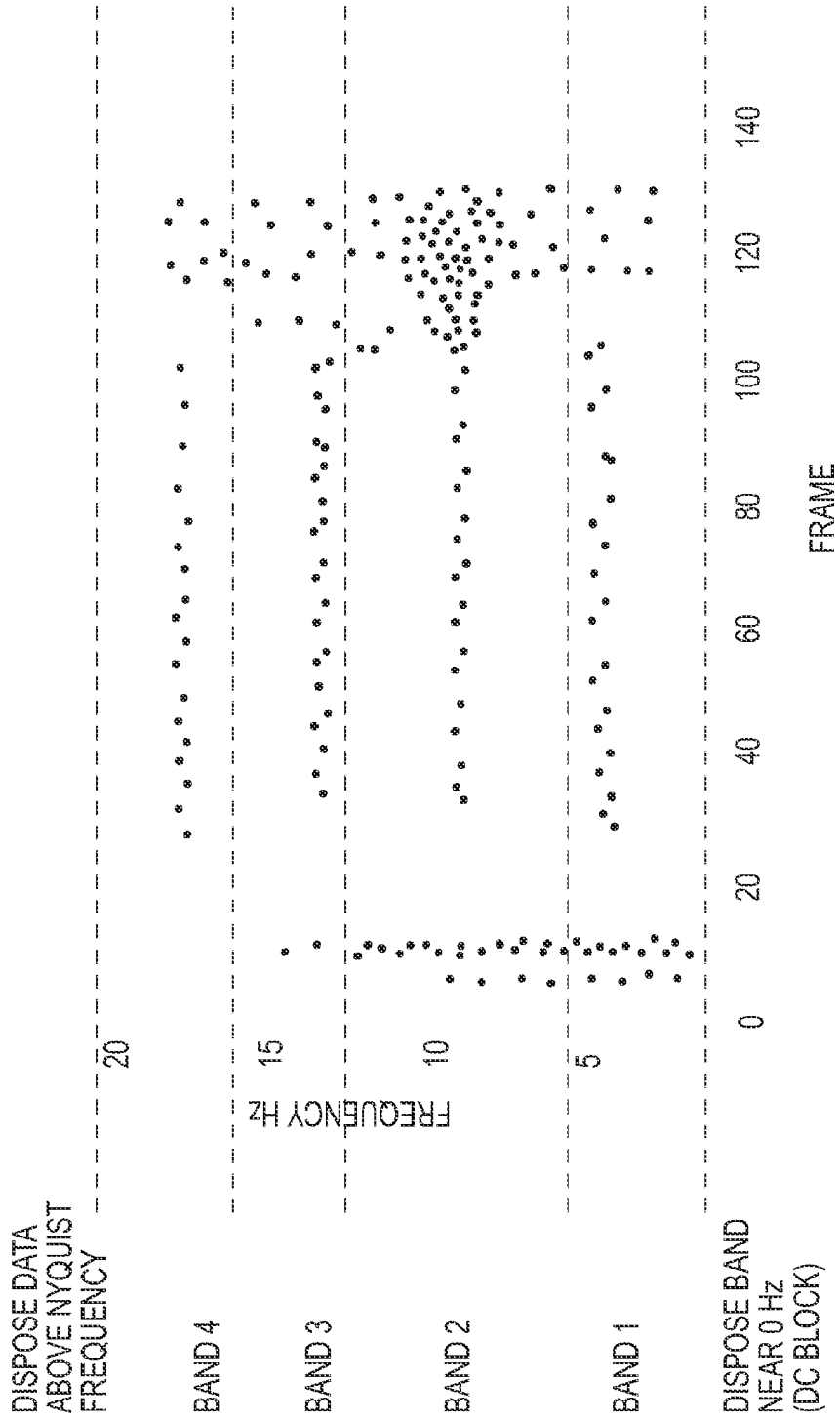

FIG.8C

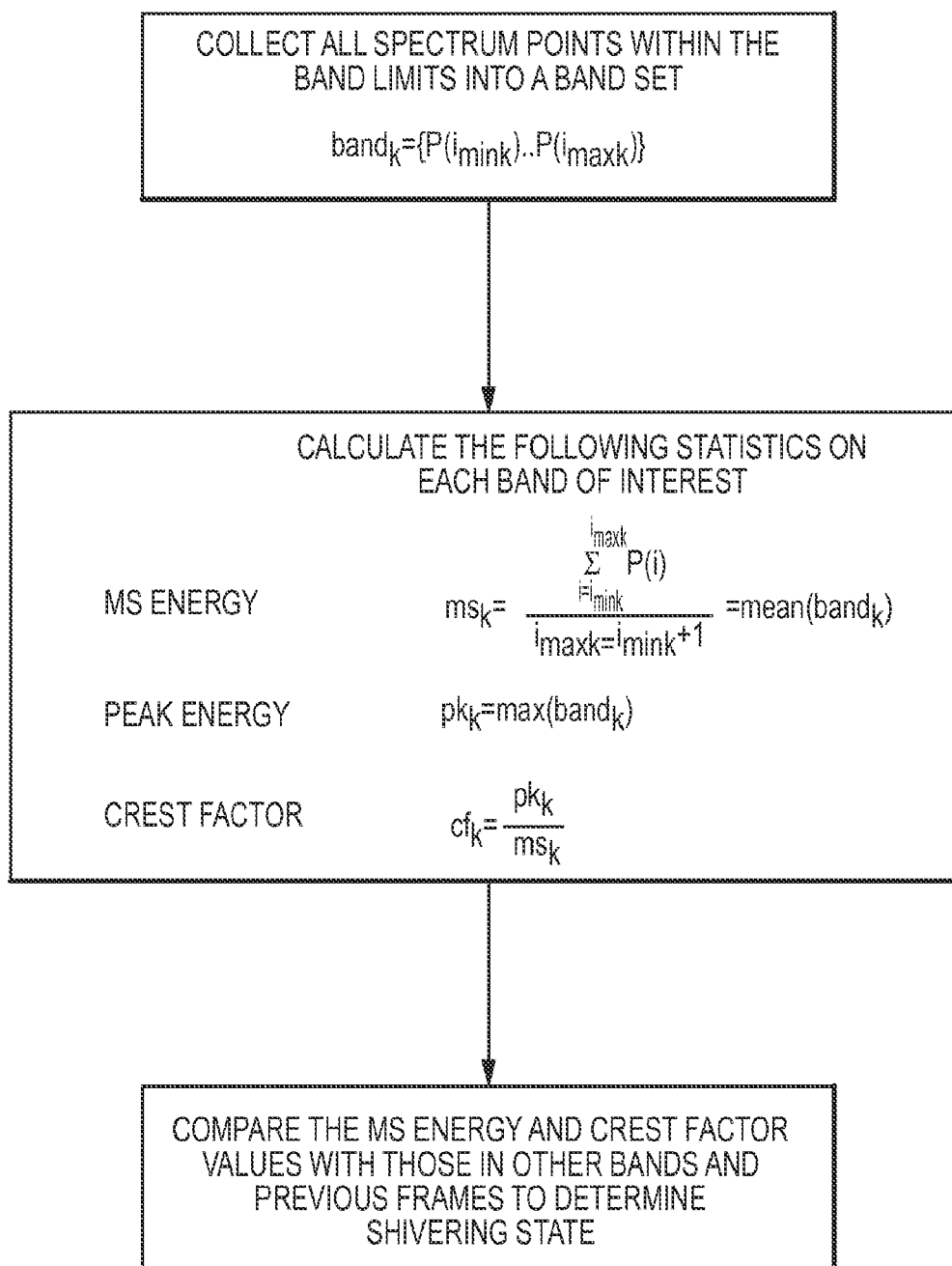

FIG. 8D

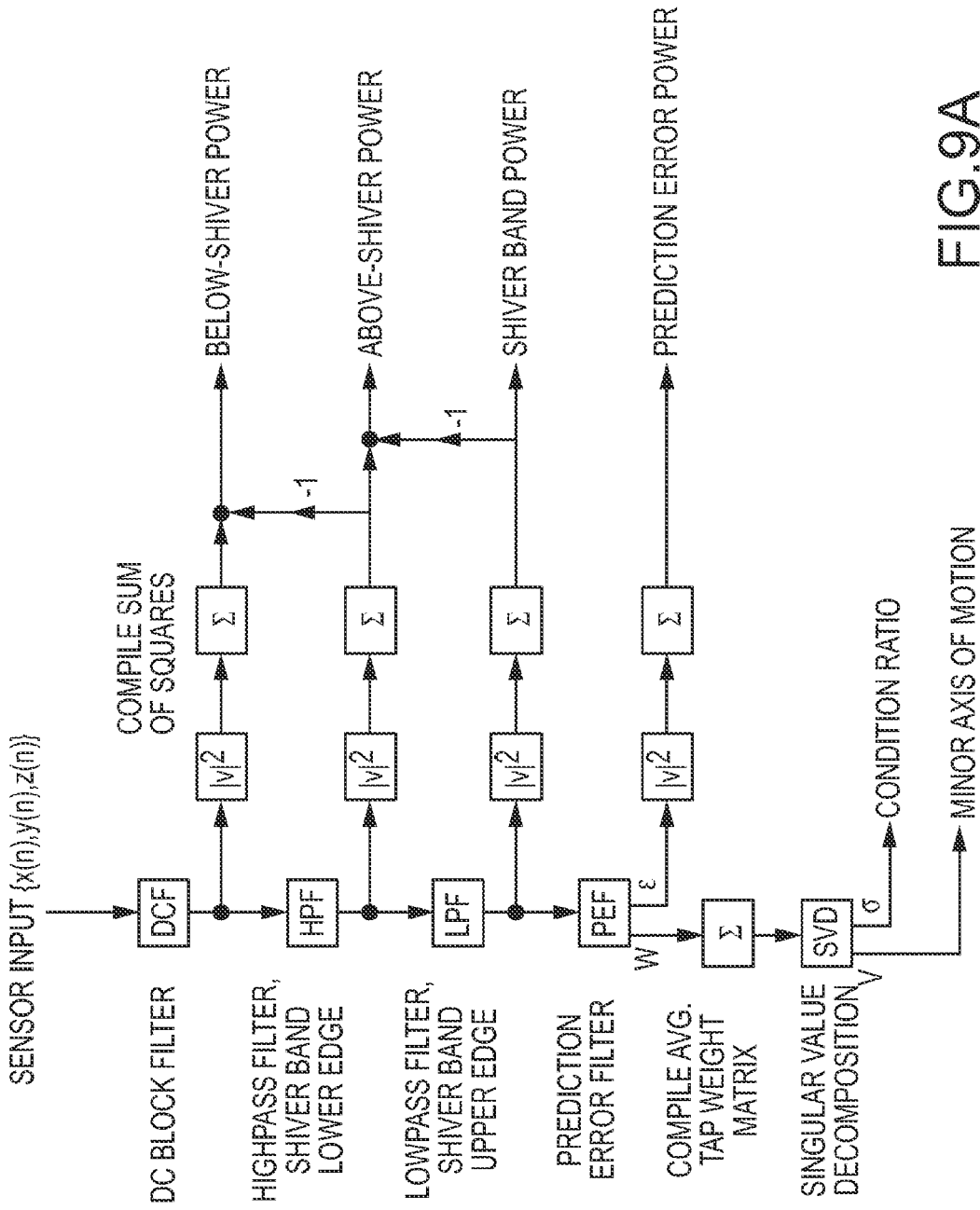
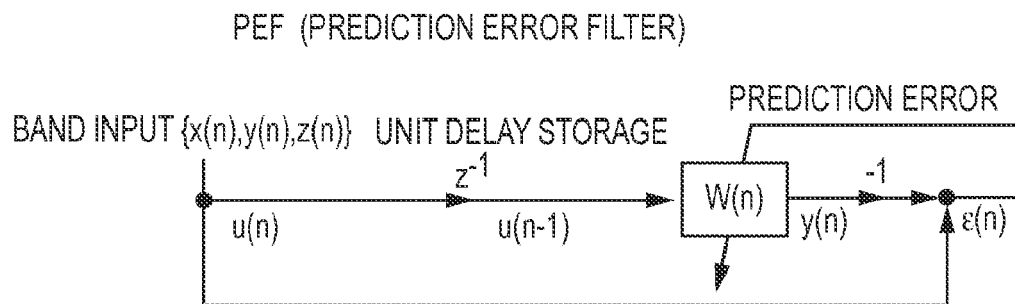

FIG. 9A



FIRST-ORDER LMS ADAPTIVE FILTER

$$y(n) = W(n) \cdot u(n-1)$$

$$\varepsilon(n) = u(n) - y(n)$$

$$W(n+1) = W(n) + ((\mu / (\sigma + |u(n-1)|^2)) (\varepsilon(n) \cdot u(n-1)^T))$$

μ AND σ ARE CONSTANT SCALARS THAT TUNE THE ADAPTIVE BEHAVIOR

FIG.9B

SVD (SINGLE VALUE DECOMPOSITION)
SPATIAL ANALYSIS

$$W_{avg} = U \cdot \Sigma \cdot V^T$$

ELLIPTICAL PARAMETERS ANALYSIS AXES
(AKA SINGULAR VALUES)

THE SMALLEST ELLIPTICAL PARAMETER, σ_{min} , CORRESPONDS TO THE AXIS OF MOST CONSTRAINED MOTION

$$\text{CONDITION RATIO} = \sigma_{max} / \sigma_{min}$$

MINOR AXIS OF MOTION = v_{min}

WHERE v_{min} IS THE COLUMN VECTOR OF V THAT CORRESPONDS TO σ_{min}

$\|v_{min}(i) \cdot v_{min}(i-1)\|$ YIELDS A VALUE BETWEEN 0 AND 1 THAT REPRESENTS THE PERSISTENCE OF THE PLANE OF MOTION FROM BLOCK TO BLOCK

FIG.9C



EUROPEAN SEARCH REPORT

Application Number
EP 18 15 6996

5

10

15

20

25

30

35

40

45

50

55

DOCUMENTS CONSIDERED TO BE RELEVANT			
Category	Citation of document with indication, where appropriate, of relevant passages	Relevant to claim	CLASSIFICATION OF THE APPLICATION (IPC)
A	EP 0 846 440 A2 (SARCOS INC [US]) 10 June 1998 (1998-06-10) * column 9, line 46 - column 10, line 37 * -----	1-15	INV. A61B5/00 A61B5/01 A61B5/026
A	US 7 294 112 B1 (DUNLOP COLIN [AU]) 13 November 2007 (2007-11-13) * column 6, line 33 - column 7, line 5; figure 2 *	1-15	A61B5/0488 A61B5/083 A61B5/11 A61B5/1455 A61F7/02 A61F7/00
A	US 6 238 354 B1 (ALVAREZ MARTIN A [US]) 29 May 2001 (2001-05-29) * column 7, line 32 - line 48 * * figure 2 * * column 4, line 9 - line 24; figure 3 * -----	1-15	
A	WO 96/36950 A1 (JOHNSON MARK [US]; SIMKINS THOMAS [US]) 21 November 1996 (1996-11-21) * page 4, line 30 - page 8, line 23 * -----	1-15	
			TECHNICAL FIELDS SEARCHED (IPC)
			A61B
The present search report has been drawn up for all claims			
Place of search Munich		Date of completion of the search 11 May 2018	Examiner Sopelana Martínez, J
CATEGORY OF CITED DOCUMENTS X : particularly relevant if taken alone Y : particularly relevant if combined with another document of the same category A : technological background O : non-written disclosure P : intermediate document		T : theory or principle underlying the invention E : earlier patent document, but published on, or after the filing date D : document cited in the application L : document cited for other reasons & : member of the same patent family, corresponding document	

EPO FORM 1503 03/02 (P04C01)

ANNEX TO THE EUROPEAN SEARCH REPORT
ON EUROPEAN PATENT APPLICATION NO.

EP 18 15 6996

5

This annex lists the patent family members relating to the patent documents cited in the above-mentioned European search report. The members are as contained in the European Patent Office EDP file on
The European Patent Office is in no way liable for these particulars which are merely given for the purpose of information.

11-05-2018

10

Patent document cited in search report	Publication date	Patent family member(s)	Publication date
EP 0846440 A2	10-06-1998	CA 2222337 A1	05-06-1998
		EP 0846440 A2	10-06-1998
		JP H10295652 A	10-11-1998
		US 6198394 B1	06-03-2001

US 7294112 B1	13-11-2007	GB 2364786 A	06-02-2002
		US 7294112 B1	13-11-2007
		US 2008091122 A1	17-04-2008
		WO 0069339 A1	23-11-2000

US 6238354 B1	29-05-2001	NONE	

WO 9636950 A1	21-11-1996	AU 5182396 A	29-11-1996
		US 5610590 A	11-03-1997
		WO 9636950 A1	21-11-1996

15

20

25

30

35

40

45

50

55

EPO FORM P0459

For more details about this annex : see Official Journal of the European Patent Office, No. 12/82

REFERENCES CITED IN THE DESCRIPTION

This list of references cited by the applicant is for the reader's convenience only. It does not form part of the European patent document. Even though great care has been taken in compiling the references, errors or omissions cannot be excluded and the EPO disclaims all liability in this regard.

Patent documents cited in the description

- US 98870607 P [0001]
- US 6669715 B [0040]
- US 6827728 B [0040] [0059]
- US 6375674 B [0040]
- US 6645232 B [0040]
- US 2007066893 W [0040]
- US 6620187 B [0059]
- US 6692518 B [0059]
- US 6818012 B [0059]

专利名称(译)	患者温度响应控制系统		
公开(公告)号	EP3366199A1	公开(公告)日	2018-08-29
申请号	EP2018156996	申请日	2008-11-17
申请(专利权)人(译)	MEDIVANCE INCORPORATED		
当前申请(专利权)人(译)	MEDIVANCE INCORPORATED		
[标]发明人	VOORHEES MARC CARSON GARY A GRUSZECKI GARY		
发明人	VOORHEES, MARC CARSON, GARY A. GRUSZECKI, GARY		
IPC分类号	A61B5/00 A61B5/01 A61B5/026 A61B5/0488 A61B5/083 A61B5/11 A61B5/1455 A61F7/02 A61F7/00		
CPC分类号	A61B5/01 A61B5/026 A61B5/0488 A61B5/0836 A61B5/11 A61B5/1455 A61B5/4035 A61B5/6814 A61B5/6824 A61B5/6828 A61B5/68335 A61B34/25 A61B2562/0219 A61F7/02 A61B5/1101 A61B5 /7435 A61F7/0097 A61F2007/0056 A61F2007/0093		
代理机构(译)	øYOUNG & CO LLP		
优先权	60/988706 2007-11-16 US PCT/US2008/083818 2008-11-17 WO		
其他公开文献	EP3366199B1		
外部链接	Espacenet		

摘要(译)

提供了一种系统，其采用监测装置来监测至少一个患者对患者体温变化的生理反应（例如，根据诱导的低温治疗），其中监测信号由监测装置提供。反过来，可以向用户提供输出（例如视觉和/或听觉输出），其指示患者对温度变化的响应的至少一个度量。提供处理器以处理监测信号以提供医疗人员可用的输出，以控制患者对患者温度变化的颤抖响应。此类信息可包括关于一种或多种抗颤抖药物的信息，例如，相应的剂量和/或频率信息供医务人员用于抗颤抖药物的给药。

