

(19)



(11)

**EP 3 138 478 A1**

(12)

**EUROPEAN PATENT APPLICATION**

(43) Date of publication:  
**08.03.2017 Bulletin 2017/10**

(51) Int Cl.:  
**A61B 5/00 (2006.01) A61B 5/024 (2006.01)**

(21) Application number: **15306343.3**

(22) Date of filing: **01.09.2015**

(84) Designated Contracting States:  
**AL AT BE BG CH CY CZ DE DK EE ES FI FR GB GR HR HU IE IS IT LI LT LU LV MC MK MT NL NO PL PT RO RS SE SI SK SM TR**  
Designated Extension States:  
**BA ME**  
Designated Validation States:  
**MA**

(72) Inventors:  
• **ROUSSEAU, Denis**  
**94227 Charenton-le-Pont Cedex (FR)**  
• **PERRIER, Eric**  
**94227 Charenton-le-Pont Cedex (FR)**

(74) Representative: **Cabinet Novitech**  
**188 Grande rue Charles de Gaulle**  
**94130 Nogent-sur-Marne (FR)**

(71) Applicant: **ESSILOR INTERNATIONAL**  
**(COMPAGNIE GENERALE D'OPTIQUE)**  
**94220 Charenton-le-Pont (FR)**

(54) **A HEART RATE SENSING MODULE**

(57) A heart rate sensing module configured to be fixed on a wearable device intended to be worn by a user, the module comprising:  
- at least one contactless sensor adapted to sense at least one parameter indicative of the distance between at least a reference point of the skin of the user and a reference point of the module when the module is fixed

to the wearable device when worn by the user in such a manner that the contactless sensor is distant from the skin of the user,  
- at least one communication entity adapted to communicate data indicative of the at least one parameter sensed by the at least one sensor to a heart rate determining component.

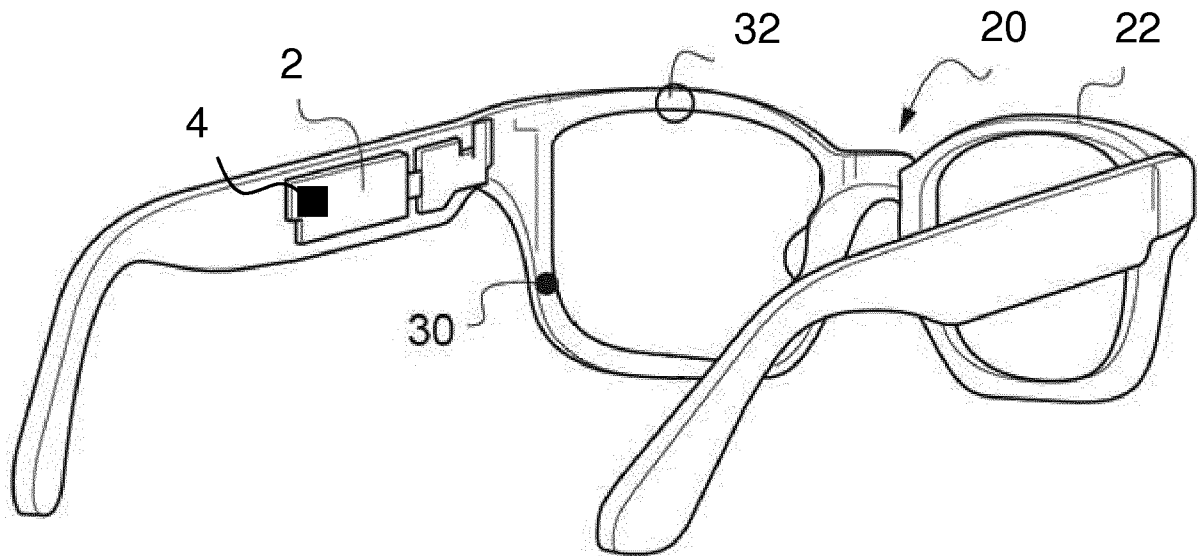

**Fig. 3**

**EP 3 138 478 A1**

**Description**FIELD OF THE INVENTION

**[0001]** The invention relates to a heart rate sensing module configured to be fixed to a wearable device intended to be worn by a user. The invention further relates to a heart rate determining component for determining the heart rate of a wearer of a heart rate sensing module according to the invention and to a wearable device comprising a heart rate sensing module according to the invention.

BACKGROUND OF THE INVENTION

**[0002]** Sensing heart rate of a user of a wearable device may provide useful information concerning the user, in particular concerning the health condition of the user. Most of the existing heart rate sensing devices requires a contact with the skin of the user. When using a wearable device on an everyday bases it may be complex ensuring permanent contact between the heart rate sensing device and the skin of the user.

**[0003]** Thus there is a need for heart rate sensing module that would not require contact with the user's skin.

**[0004]** One object of the present invention is to provide a monitoring component allowing monitoring the heart rate of a user of a wearable device.

SUMMARY OF THE INVENTION

**[0005]** To this end, the invention proposes a heart rate sensing module configured to be fixed on a wearable device intended to be worn by a user, the module comprising:

- at least one contactless sensor adapted to sense at least one parameter indicative of the distance between at least a reference point of the skin of the user and a reference point of the module when the module is fixed to the wearable device when worn by the user in such a manner that the contactless sensor is distant from the skin of the user,
- at least one communication entity adapted to communicate data indicative of the at least one parameter sensed by the at least one sensor to a heart rate determining component.

**[0006]** The sensing module according to the invention allows monitoring the heart rate of the user without contact between the sensor and the skin of the user.

**[0007]** Advantageously, such sensing module may be placed, for example on a spectacle frame, in a greater diversity of positions than the sensing devices requiring contact with the skin.

**[0008]** According to further embodiments which can be considered alone or in combination:

- the heart rate sensing module is configured to be fixed on a spectacle frame; and/or
- the heart rate sensing module is configured so that when fixed on the wearable device and said wearable device worn by the user the distance between the contactless sensor and the skin of the user is greater than or equal to 0.1 mm and smaller than or equal to 5 mm; and/or
- the heart rate sensing module is configured so that when fixed on the wearable device and said wearable device worn by the user, the contactless sensor faces an artery or vein of the user; and/or
- the contactless sensor is a capacitive sensor; and/or
- the at least one parameter relates to the capacitance measured by the capacitive sensor; and/or
- the contactless sensor is a magnetic sensor; and/or
- the at least one parameter relates to the of magnetic field measured by the magnetic sensor.

**[0009]** The invention also relates to a heart rate determining component for determining the heart rate of a wearer of a wearable sensing device according to the invention, the heart rate determining component comprising:

- a communication unit configured to receive data indicative of the at least one parameter sensed by the at least one sensor of a heart rate sensing module according to the invention, and
- a heart rate unit comprising at least
- a memory configured to store computer executable instructions; and
- a processor for executing the computer executable instructions,

wherein the computer executable instructions comprises instructions for determining heart rate data indicative of the heart rate of the user based on the received data.

**[0010]** According to further embodiments which can be considered alone or in combination:

- the computer executable instructions further comprises instructions for determining heart rate data based on the variation over time of the distance between the at least a reference point of the skin of the user and a reference point of the module when the module is fixed to the wearable device worn by the user; and/or
- further comprising an information generating unit configured to generate information based on the heart rate data; and/or
- the information comprises recommendation data including a change of activity recommendation and/or an alert indicative of the user's heart state and/or an access to a service offer; and/or
- the communication unit is configured to send heart rate related data to a distant entity, for example a wearable computer device and/or a personal com-

puter device, associated to the user of the heart rate determining component.

**[0011]** According to a further aspect, the invention relates to a wearable device comprising a heart rate sensing module according to the invention.

**[0012]** The wearable device according to the invention may further comprise a heart rate determining component according to the invention.

**[0013]** The wearable device may be a head mounted device comprising a frame to be mounted on the head of the wearer and the heart rate sensing module is fixed to the frame.

**[0014]** Unless specifically stated otherwise, as apparent from the following discussions, it is appreciated that throughout the specification discussions utilizing terms such as "computing", "calculating", or the like, refer to the action and/or processes of a computer or computing system, or similar electronic computing device, that manipulate and/or transform data represented as physical, such as electronic, quantities within the computing system's registers and/or memories into other data similarly represented as physical quantities within the computing system's memories, registers or other such information storage, transmission or display devices.

**[0015]** Embodiments of the present invention may include apparatuses for performing the operations herein. This apparatus may be specially constructed for the desired purposes, or it may comprise a general purpose computer or Digital Signal Processor ("DSP") or FPGA selectively activated or reconfigured by a computer program or computer executable instructions stored in the computer. Such a computer program or computer executable instructions may be stored in a computer readable storage medium, such as, but is not limited to, any type of disk including floppy disks, optical disks, CD-ROMs, magnetic-optical disks, read-only memories (ROMs), random access memories (RAMs), ferro magnetic RAM, electrically programmable read-only memories (EPROMs), electrically erasable and programmable read only memories (EEPROMs), magnetic or optical cards, or any other type of media suitable for storing electronic instructions, and capable of being coupled to a computer system bus.

**[0016]** The processes and displays presented herein are not inherently related to any particular computer or other apparatus. Various general purpose systems may be used with programs in accordance with the teachings herein, or it may prove convenient to construct a more specialized apparatus to perform the desired method.

**[0017]** The desired structure for a variety of these systems will appear from the description below. In addition, embodiments of the present invention are not described with reference to any particular programming language. It will be appreciated that a variety of programming languages may be used to implement the teachings of the inventions as described herein.

## BRIEF DESCRIPTION OF THE DRAWINGS

**[0018]** Embodiments of the invention will now be described, by way of example only, and with reference to the following drawings in which:

- Figure 1 is a schematic representation of a heart rate sensing module according to the invention,
- Figure 2 is a schematic representation of a heart rate determining component according to the invention,
- Figure 3 is a schematic representation of an head mounted device according to an embodiment of the invention;
- Figure 4 represents a networked data-processing device according to the invention; and
- Figure 5 is a schematic representation of a head mounted device according to a further embodiment of the invention.

## DETAILED DESCRIPTION OF PREFERRED EMBODIMENTS

**[0019]** Elements in the figures are illustrated for simplicity and clarity and have not necessarily been drawn to scale. For example, the dimensions of some of the elements in the figure may be exaggerated relative to other elements to help improve the understanding of the embodiments of the present invention.

**[0020]** As represented on figure 1, the invention relates to a heart rate sensing module 2. The heart rate sensing module is configured to be fixed on a wearable device, the wearable device being intended to be worn by a user.

**[0021]** The wearable device may be a head mounted device such as a spectacle frame, as represented on figure 2, or a pair of shoes or a watch.

**[0022]** The heart rate sensing module 2 comprises at least a contactless sensor 4 and a communication entity 6.

**[0023]** The contactless sensor 4 is adapted to sense at least one parameter indicative of the distance between at least a reference point of the skin of the user and a reference point of the module, in particular of the contactless sensor, when the module is fixed to the wearable device when worn by the user in such a manner that the contactless sensor is distant from the skin of the user.

**[0024]** Preferably, when the heart rate sensing module is fixed on the wearable device and said wearable device is worn by the user the distance between the contactless sensor, in particular the at least one reference point of the contactless sensor and the skin of the user, in particular the reference point of the of the skin of the use, is greater than or equal to 0.1 mm, for example greater than or equal to 1 mm and smaller than or equal to 1 cm, for example smaller than or equal to 7 mm.

**[0025]** So as to provide more accurate heart rate sensing, the heart rate sensing module may be configured to that when fixed on the wearable device and said wearable device worn by the user, the contactless sensor faces an

artery or vein of the user.

**[0026]** The contactless sensor may be a capacitive sensor. The capacitance measured by the capacitive sensor may be used as an indication of the distance between the sensor and the skin of the user.

**[0027]** Typically, the electrode of the capacitive sensor can be printed on a circuit board fixed onto a wearable device or can be mounted directly into the wearable device or printed with conductive ink directly on the wearable device. The electrode may be flexible and the sensor may be embedded into clothes, for example using conductive wires like sliver nanowires embedded into standard clothes.

**[0028]** When the electrode of the capacitive sensor is approached by a distant object, like a finger or human skin, the capacitance of the circuit changes. The formula to determine capacitance is as follow :

$$C = (\epsilon_0 * \epsilon_r) * S / e , \text{ with}$$

$\epsilon_0$  is the air dielectric constant,

$\epsilon_r$  is the relative dielectric constant of the material between skin and electrode,

$e$  is the distance between the electrode and the distant object,

$S$  is the surface of the electrodes

**[0029]** Blood when flowing in the vein and arteria induces a vein and arteria diameter variation and induces a small skin variation. Such skin variation can be detected by a capacitance measurement between the sensor and the skin of the user facing the sensor at a distance greater than or equal to 1 mm and smaller than or equal to 1 cm.

**[0030]** Standard electronic chips are available to measure the capacitance variation induced by the distance variation between the sensor and the skin due to blood flow.

**[0031]** The contactless sensor may also be a magnetic sensor measuring the variation of magnetic field between two magnetic elements, one on the wearable device and one on the skin of the user, for example a magnet is stuck on the user's skin. In this case the magnetic sensor is on the wearable device and measure the magnetic field variation due to skin movement when blood flow.

**[0032]** The communication entity 6 of the heart rate sensing module 2 is adapted to communicate data indicative of the at least one parameter sensed by the at least one sensor to a heart rate determining component.

**[0033]** The data indicative of the at least one parameter sensed by the at least one sensor may be filtered to improve the accuracy, for example using a specific software and by selecting only the bandwidth of the heartbeat. This could be done using Fourier transform or other frequency filtering methods.

**[0034]** As illustrated on figure 1, the heart rate sensing module may comprise a memory 8 to store the data prior

to sending them to a heart rate determining component.

**[0035]** The heart rate sensing module may further comprise a power source, such as a battery, or may be electrically connected to a power source of a heart rate determining component or a power source comprised in the wearable device.

**[0036]** The invention further relates to a heart rate determining component for determining the heart rate of a wearer of a wearable sensing device according to the invention.

**[0037]** As illustrated on figure 2, the heart rate determining component 10 according to the invention comprises a communication unit 12 and a heart rate unit 14.

**[0038]** The communication unit 12 is configured to receive data indicative of the at least one parameter sensed by the at least one sensor of a heart rate sensing module according to the invention.

**[0039]** The communication unit 12 communicates with the communication entity 6 of a heart rate sensing module of the invention. Such communication may be wireless or both communication units may be linked electrically. Wireless communication can be done through different communication and protocols, like Bluetooth, Zigbee, WiFi or others.

**[0040]** The heart rate unit comprises at least a memory 141 and a processor 142. The memory 141 stores computer executable instructions. In addition to the computer executable instructions, the memory may store data such as at least part of the data received by the communication unit 12 or part of the data determined by the processor when executing the computer executable instructions stored in the memory.

**[0041]** The processor 142 is configured to execute the computer executable instructions stored in the memory 141. The stored computer executable instructions comprise instructions for determining heart rate data indicative of the heart rate of the user based on the received data.

**[0042]** According to an embodiment, the computer executable instructions further comprises instructions for determining heart rate data based on the variation over time of the distance between the at least a reference point of the skin of the user and a reference point of the module when the module is fixed to the wearable device worn by the user.

**[0043]** As illustrated on figure 2, the heart rate determining component 10 may further comprise an information generating unit 16 configured to generate information based on the heart rate data.

**[0044]** The information may comprise the information comprises recommendation data including a change of activity recommendation and/or an alert indicative of the user's heart state and/or an access to a service offer.

**[0045]** The communication unit 12 may be further configured to send heart rate related data to a distant entity, for example a wearable computer device and/or a personal computer device, associated to the user of the heart rate determining component. The heart rate related data

may be information generated by the information generating unit 16 or data indicative of the heart rate of the user to be processed by the distant entity.

**[0046]** The heart rate determining component may further comprise a power source, such as a battery, or may be electrically connected to a power source of a heart rate sensing module or a power source comprised in the wearable device.

**[0047]** The invention further relates to a wearable device comprising a heart rate module according to the invention. The wearable device may further comprise a heart rate determining component arranged to receive data from the heart rate module.

**[0048]** Figure 3 illustrates an example of a wearable device, for example a head-mounted device 20, comprising a heart rate sensing module 2. The wearable device may further comprise different type of sensors 30, 32. The head mounted device 20 comprises a spectacle frame 12 and the sensors and communication unit are mounted on the spectacle frame 12.

**[0049]** Although the invention is not limited to such type of wearable device, head-mounted device, appear to be particularly advantageous, in particular head mounted devices comprising a spectacle frame.

**[0050]** Indeed, such type of head mounted device is more likely to be positioned over a long period of time facing a skin of the wearer, in particular facing the posterior auricular artery or vein.

**[0051]** The sensors 30 and 32 may be configured to sense at least one feature indicative of the relative position of the head mounted device and at least one reference point of the head of the user of the head mounted device.

**[0052]** Advantageously, having an indication of the relative position of the head mounted device and the head of the user can be used to increase the accuracy of the measurements of the heart rate using the heart rate sensing module of the invention. Indeed, the heart rate sensing module senses data indicative of the distance between the sensor and the skin of the user. Thus, having an indication of the relative position of the sensor and the skin over time may be correlated to the data provided by the heart rate sensing module to increase the accuracy.

**[0053]** At least one of the additional sensors may be a time of flight sensor configured to sense the distance between the head mounted device and the user of the head mounted device, for example the user's head. Such sensor may be placed on the frame in such position that when the head mounted device is worn by the user the sensor points to the face of the wearer. The sensor typically uses time of flight (TOF) technology and is arranged to provide data indicative of the distance to the head depending of the position of the head mounted device.

**[0054]** According to an embodiment of the invention, at least one of the additional sensor is a proximity sensor based on infrared reflectance on the user skin so as to sense the proximity between the head mounted device

and the user of the head mounted device, for example the user's head.

**[0055]** Such infrared reflectance sensor may advantageously be placed on the nose bridge of the frame of the head mounted device and oriented toward the nose so as to provide data indicative of the distance to the skin of the user, for example of the sellion of the user. Advantageously, when the head mounted device is worn by the user, the nose bridge sensor is very close to the skin of the user, and if the position of the head mounted device changes this distance increases and can be easily detected.

**[0056]** The time of flight and the infrared reflectance sensors may require training to detect distance during the different use of the head mounted device, and detection of the different positions occur after statistical analysis of the data provided by the sensors.

**[0057]** According to a further embodiment of the invention, one of the additional sensors is an accelerometer and/or gyroscope configured to sense the orientation of the head mounted device.

**[0058]** Typically, in a first reference position, the head mounted device is almost horizontal, and in other position the head mounted device may be oriented upward or downward, this inclination can be measured by 3 or 6 axis sensors commonly used in mobile phone. Typically, a 3 axis accelerometer can provide data concerning the horizontality of the head mounted device and a 3 axis gyroscope can provide data concerning rotation of the head mounted device. Also the movements of the head mounted device from one position to another can be detected, and differentiated from head movement to be sure to detect a head mounted device relative movement. In some case only accelerometer can be used, to save power.

**[0059]** The different type of sensors provide features indicative that need to be processed so as to determine information indicative of the relative position of the head mounted device and the user of the head mounted device.

**[0060]** Although not represented, the head mounted device may further comprise a power source, for example a battery and/or other electronics.

**[0061]** According to an embodiment of the invention, illustrated on figure 4, the head mounted device communicates with a distant entity that comprises a heart rate determining component. Communication can be done through different communication devices and protocols, like Bluetooth, Zigbee, WiFi or others.

**[0062]** For example, the communication unit is configured to communicate with the distance entity either to store the measured features in a memory MEM or to provide information relating to the heart rate of the user.

**[0063]** Typically, the distant entity comprises a heart rate determining component according to the invention.

**[0064]** The distance entity can include different computing objects such as personal digital assistants, audio/video devices, mobile phones, MPEG-1 Audio Layer

3 (MP3) players, personal computers, laptops, tablets, bluetooth headset, watch, wristband, etc...

**[0065]** Each computing object and the head mounted device can communicate with one or more other by way of a communication network, either directly or indirectly. Even though illustrated as a single element in figure 4, network can include other computing objects and computing devices that provide services to the system of figure 4, and/or can represent multiple interconnected networks, which are not shown.

**[0066]** In a network environment in which the communications network/bus can be the Internet, the computing objects can be Web servers, file servers, media servers, etc. with which the client computing objects or devices communicate via any of a number of known protocols, such as the hypertext transfer protocol (HTTP).

**[0067]** In an alternative embodiment, the heart rate determining component may be embodied in the wearable device and electrically connected to the heart rate sensing module.

**[0068]** According to an embodiment of the invention, the data received by the heart rate determining component from the heart rate sensing module may be stored over time and the information is indicative of the evolution over time of the heart rate of the user.

**[0069]** Furthermore the information generating unit may be configured to generate information using statistical analysis of the data received from the head mounted device and stored over time.

**[0070]** Statistics involves the collection, organization, analysis, interpretation, and/or presentation of measured/collected information. With advances in technology, more extensive and complex computing allows massive amounts of data to be collected, stored and/or processed. Further, methods for evaluating the data are numerous.

**[0071]** Statistical analysis can be employed to process and/or evaluate data sensed.

**[0072]** As represented on figure 4, the head mounted device according to the invention may comprise a virtual image display device 50, preferably allowing the wearer to see both the virtual image and the real world through it. The virtual image display device is able to display graphical images, and an electronic driving system (memory + processor) sends to the virtual display image the image to display. For example the heart rate over time may be displayed or an alert may be displayed if a heart or health defect is detected.

**[0073]** The invention has been described above with the aid of embodiments without limitation of the general inventive concept.

**[0074]** Many further modifications and variations will suggest themselves to those skilled in the art upon making reference to the foregoing illustrative embodiments, which are given by way of example only and which are not intended to limit the scope of the invention, that being determined solely by the appended claims.

**[0075]** In the claims, the word "comprising" does not exclude other elements or steps, and the indefinite article

"a" or "an" does not exclude a plurality. The mere fact that different features are recited in mutually different dependent claims does not indicate that a combination of these features cannot be advantageously used. Any reference signs in the claims should not be construed as limiting the scope of the invention.

## Claims

1. A heart rate sensing module configured to be fixed on a wearable device intended to be worn by a user, the module comprising:
  - at least one contactless sensor adapted to sense at least one parameter indicative of the distance between at least a reference point of the skin of the user and a reference point of the module when the module is fixed to the wearable device when worn by the user in such a manner that the contactless sensor is distant from the skin of the user,
  - at least one communication entity adapted to communicate data indicative of the at least one parameter sensed by the at least one sensor to a heart rate determining component.
2. The heart rate sensing module according to claim 1, configured to be fixed on a spectacle frame.
3. The heart rate sensing module according to any of claim 1 or 2, wherein the heart rate sensing module is configured so that when fixed on the wearable device and said wearable device worn by the user the distance between the contactless sensor and the skin of the user is greater than or equal to 0.1 mm and smaller than or equal to 5 mm.
4. The heart rate sensing module according to any of the preceding claims, wherein the heart rate sensing module is configured so that when fixed on the wearable device and said wearable device worn by the user, the contactless sensor faces an artery or vein of the user.
5. The heart rate sensing module according to any of the preceding claims, wherein the contactless sensor is a capacitive sensor.
6. The heart rate sensing module according to the preceding claim, wherein the at least one parameter relates to the capacitance measured by the capacitive sensor.
7. The heart rate sensing module according to any of claims 1 to 4, wherein the contactless sensor is a magnetic sensor.

8. A heart rate determining component for determining the heart rate of a wearer of a wearable sensing device according to any of the preceding claims, the heart rate determining component comprising:
- a communication unit configured to receive data indicative of the at least one parameter sensed by the at least one sensor of a heart rate sensing module according to any of the preceding claims, and
  - a heart rate unit comprising at least
  - a memory configured to store computer executable instructions; and
  - a processor for executing the computer executable instructions,
- wherein the computer executable instructions comprises instructions for determining heart rate data indicative of the heart rate of the user based on the received data.
9. The heart rate determining component according to claim 8, wherein the computer executable instructions further comprises instructions for determining heart rate data based on the variation over time of the distance between the at least a reference point of the skin of the user and a reference point of the module when the module is fixed to the wearable device worn by the user.
10. The heart rate determining component according to claim 8 or 9, further comprising an information generating unit configured to generate information based on the heart rate data.
11. The heart rate determining component according to the preceding claim, wherein the information comprises recommendation data including a change of activity recommendation and/or an alert indicative of the user's heart state and/or an access to a service offer.
12. The heart rate determining component according to any of claims 8 to 11, wherein the communication unit is configured to send heart rate related data to a distant entity, for example a wearable computer device and/or a personal computer device, associated to the user of the heart rate determining component.
13. A wearable device comprising a heart rate sensing module according to any of claims 1 to 7.
14. The wearable device according to claim 13, further comprising a heart rate determining component according to claim 8 to 12.
15. The wearable device according to claim 13 or 14,

wherein the wearable device is a head mounted device comprising a frame to be mounted on the head of the wearer and the heart rate sensing module is fixed to the frame.

5

10

15

20

25

30

35

40

45

50

55

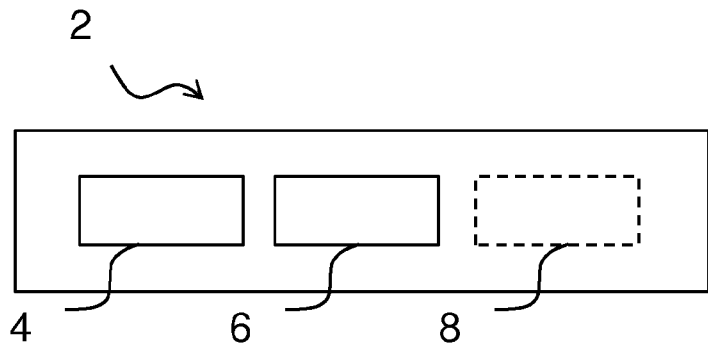

Fig. 1

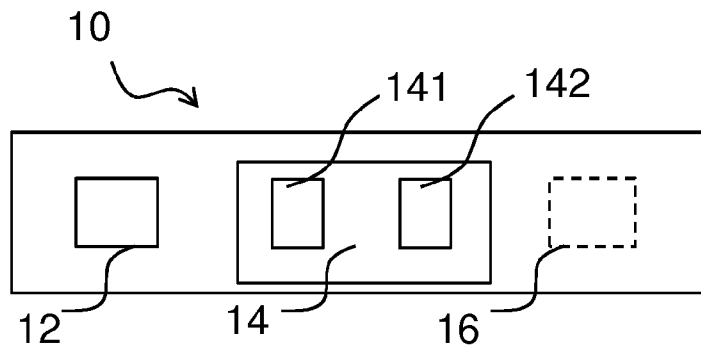

Fig. 2

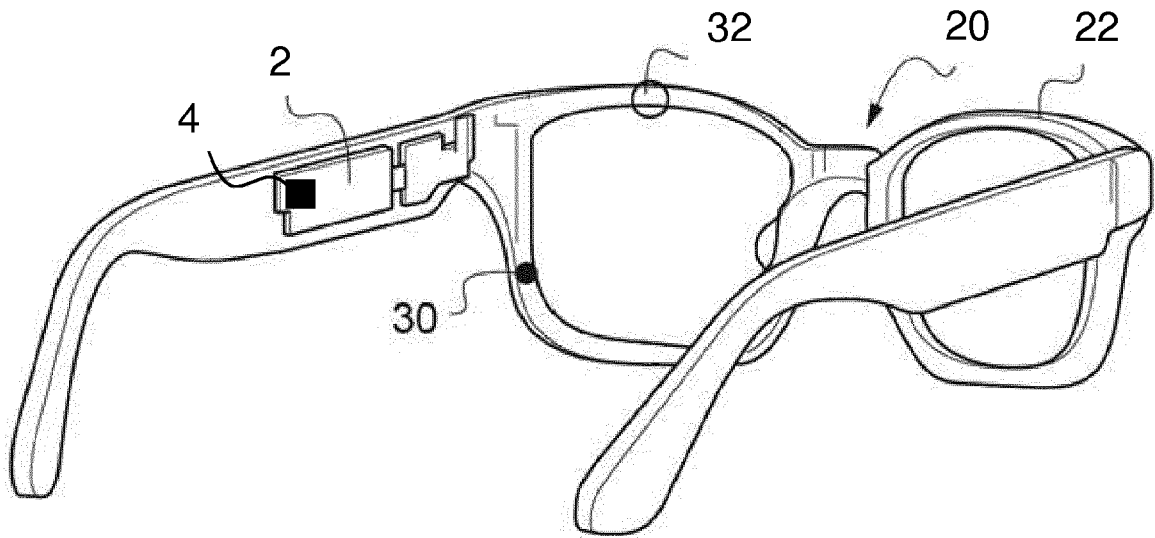

Fig. 3

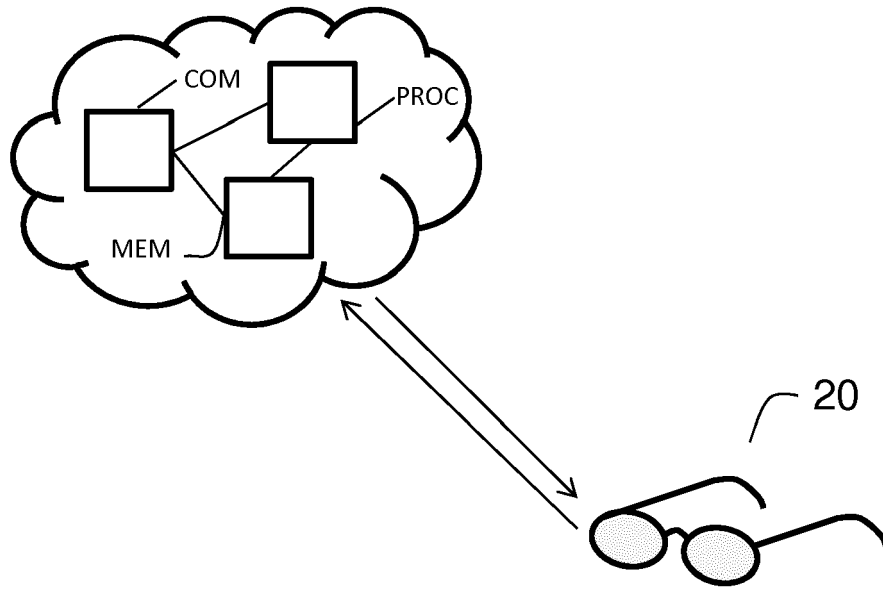

Fig. 4

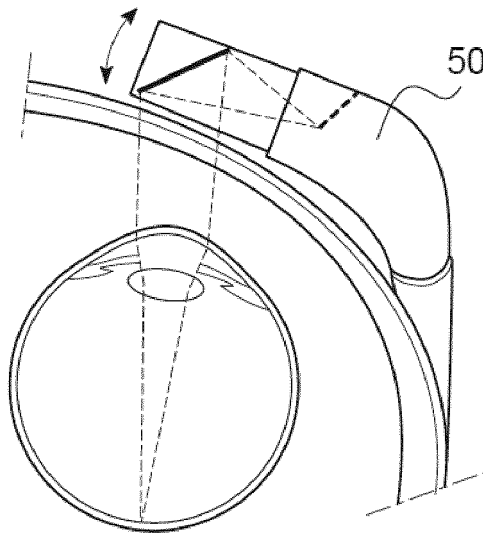

Fig. 5



EUROPEAN SEARCH REPORT

Application Number  
EP 15 30 6343

5

10

15

20

25

30

35

40

45

50

55

DOCUMENTS CONSIDERED TO BE RELEVANT			
Category	Citation of document with indication, where appropriate, of relevant passages	Relevant to claim	CLASSIFICATION OF THE APPLICATION (IPC)
X	US 2015/051468 A1 (SRINIVASA MURALI [US] ET AL) 19 February 2015 (2015-02-19) * paragraphs [0003], [0010], [0018], [0051], [0053] * * figures 1,4 *	1-15	INV. A61B5/00 A61B5/024
X	US 2015/045650 A1 (SRINIVASA MURALI [US] ET AL) 12 February 2015 (2015-02-12) * paragraphs [0003], [0016], [0028], [0033], [0044] * * figure 4 *	1-15	
X	WO 2010/140106 A1 (KONINKL PHILIPS ELECTRONICS NV [NL]; MEFTAH MOHAMMED [NL]; FEDDES BAST) 9 December 2010 (2010-12-09) * pages 3-4,8 * * figure 1 *	1-15	
X	US 2014/200469 A1 (BOCKO MARK F [US] ET AL) 17 July 2014 (2014-07-17) * paragraphs [0026] - [0027], [0034]; figures 1, 2A *	1-15	TECHNICAL FIELDS SEARCHED (IPC)
A	WO 2013/049248 A2 (OSTERHOUT GROUP INC [US]) 4 April 2013 (2013-04-04) * paragraph [0624] *	11	A61B
The present search report has been drawn up for all claims			
Place of search <b>The Hague</b>		Date of completion of the search <b>22 February 2016</b>	Examiner <b>Vanderperren, Yves</b>
CATEGORY OF CITED DOCUMENTS X : particularly relevant if taken alone Y : particularly relevant if combined with another document of the same category A : technological background O : non-written disclosure P : intermediate document T : theory or principle underlying the invention E : earlier patent document, but published on, or after the filing date D : document cited in the application L : document cited for other reasons & : member of the same patent family, corresponding document			

EPO FORM 1503 03 02 (P04C01)

ANNEX TO THE EUROPEAN SEARCH REPORT  
ON EUROPEAN PATENT APPLICATION NO.

EP 15 30 6343

5

This annex lists the patent family members relating to the patent documents cited in the above-mentioned European search report. The members are as contained in the European Patent Office EDP file on  
The European Patent Office is in no way liable for these particulars which are merely given for the purpose of information.

22-02-2016

10

15

20

25

30

35

40

45

50

55

Patent document cited in search report	Publication date	Patent family member(s)	Publication date
US 2015051468 A1	19-02-2015	NONE	
US 2015045650 A1	12-02-2015	NONE	
WO 2010140106 A1	09-12-2010	CN 102458239 A EP 2437657 A1 JP 5597703 B2 JP 2012528654 A RU 2011153667 A US 2012062253 A1 WO 2010140106 A1	16-05-2012 11-04-2012 01-10-2014 15-11-2012 20-07-2013 15-03-2012 09-12-2010
US 2014200469 A1	17-07-2014	NONE	
WO 2013049248 A2	04-04-2013	CN 103946732 A EP 2761362 A2 JP 2015504616 A KR 20140066258 A WO 2013049248 A2	23-07-2014 06-08-2014 12-02-2015 30-05-2014 04-04-2013

EPO FORM P0459

For more details about this annex : see Official Journal of the European Patent Office, No. 12/82

专利名称(译)	心率感应模块		
公开(公告)号	<a href="#">EP3138478A1</a>	公开(公告)日	2017-03-08
申请号	EP2015306343	申请日	2015-09-01
[标]申请(专利权)人(译)	埃西勒国际通用光学公司		
申请(专利权)人(译)	ESSILOR INTERNATIONAL ( COMPAGNIE GENERALE D'OPTIQUE )		
当前申请(专利权)人(译)	ESSILOR INTERNATIONAL		
[标]发明人	ROUSSEAU DENIS PERRIER ERIC		
发明人	ROUSSEAU, DENIS PERRIER, ERIC		
IPC分类号	A61B5/00 A61B5/024		
CPC分类号	A61B5/02438 A61B5/6803 A61B5/6886 A61B5/7278 A61B2562/0257		
审查员(译)	VANDERPERREN , YVES		
外部链接	<a href="#">Espacenet</a>		

摘要(译)

1.一种心率感测模块，被配置为固定在旨在由用户佩戴的可穿戴设备上，所述模块包括：至少一个非接触式传感器，适于感测至少一个参数，所述至少一个参数指示至少一个参考点当所述模块在被所述用户佩戴时以所述非接触式传感器远离所述用户的皮肤的方式固定到所述可穿戴式设备时，所述用户的皮肤和所述模块的参考点， - 至少一个通信实体，适于将指示由所述至少一个传感器感测的所述至少一个参数的数据传送到心率确定组件。

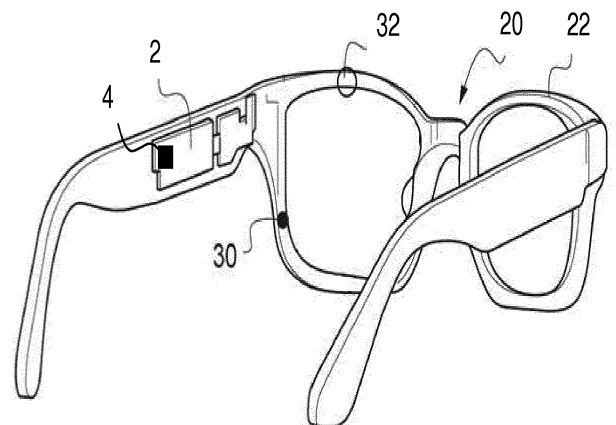

Fig. 3