



(11) **EP 1 455 889 B1**

(12) **EUROPEAN PATENT SPECIFICATION**

(45) Date of publication and mention of the grant of the patent:
08.06.2011 Bulletin 2011/23

(51) Int Cl.:
A61N 1/00 ^(2006.01) **A61N 1/365** ^(2006.01)
A61B 5/00 ^(2006.01)

(21) Application number: **02795535.0**

(86) International application number:
PCT/US2002/033521

(22) Date of filing: **18.10.2002**

(87) International publication number:
WO 2003/035139 (01.05.2003 Gazette 2003/18)

(54) **STEERABLE CATHETER FOR LOCATING CORONARY SINUS**

STEUERBARER KATHETER ZUR LOKALISIERUNG DES KORONARSINUS

CATHETER DIRIGEABLE POUR LOCALISATION DU SINUS CORONAIRE

(84) Designated Contracting States:
**AT BE BG CH CY CZ DE DK EE ES FI FR GB GR
IE IT LI LU MC NL PT SE SK TR**

(30) Priority: **23.10.2001 US 44587**

(43) Date of publication of application:
15.09.2004 Bulletin 2004/38

(73) Proprietor: **THE ADMINISTRATORS OF THE
TULANE EDUCATIONAL FUND
New Orleans, LA 70112-2699 (US)**

(72) Inventor: **PIGOTT, John, D.
New Orleans, LA 70130 (US)**

(74) Representative: **Roberts, Gwilym Vaughan et al
Kilburn & Strode LLP
20 Red Lion Street
London WC1R 4PJ (GB)**

(56) References cited:
**US-A- 3 847 483 US-A- 5 199 428
US-A- 5 843 132 US-A- 6 122 552
US-A- 6 122 552 US-B1- 6 264 627
US-B1- 6 264 627**

EP 1 455 889 B1

Note: Within nine months of the publication of the mention of the grant of the European patent in the European Patent Bulletin, any person may give notice to the European Patent Office of opposition to that patent, in accordance with the Implementing Regulations. Notice of opposition shall not be deemed to have been filed until the opposition fee has been paid. (Art. 99(1) European Patent Convention).

Description

Technical Field of the Invention

[0001] This invention relates generally to medical devices for locating the coronary sinus of a heart and placing an electrical lead for use with an implantable pulse generator.

Background of the Invention

[0002] Many cardiac disorders, such as bradycardia, tachycardia and ventricular fibrillation, for example, involve abnormalities of cardiac rhythm or rate. Implantable electrical pulse generators are commonly used to treat such disorders. Modern implantable pulse generators include an hermetically sealed housing containing control electronics and a battery, and have standard connectors to which implantable electrical leads can be connected. Such leads include insulated conductors and one or more exposed electrodes near the distal end of the lead for electrically connecting the pulse generator to one or more chambers of the heart. Sensing electrodes sense the electrical activity of the heart so that electrical markers of the electrocardiogram such as the P-wave or R-wave can be detected. Stimulating electrodes conduct pulses of electrical energy from the pulse generator to excitable cardiac tissue. Often both types of electrodes are employed, with the nature and timing of the stimulation pulses being related to the sensed electrical activity. Selected placement of the leads and electrodes permits delivery of therapeutic electrical pulses appropriate to the disorder to be treated.

[0003] Lead systems for use with modern implantable pulse generators can include single lead systems and multiple lead systems, with single or dual chamber sensing or therapy. Some systems provide four-chamber sensing and therapy. Examples of such systems can be found in Dual Chamber Cardiac Pacing from a Single Electrode, U.S. Patent No. 5,265,601; Bi-atrial and/or Bi-ventricular Sequential Cardiac Pacing Systems, U.S. Patent No. 5,902,324; Bi-ventricular Pacing Method, U.S. Patent No. 6,223,079; and Multiple Channel Sequential Cardiac Pacing Method, U.S. Patent No. 6,122,545.

[0004] Although leads and electrodes can be applied directly to the epicardium via thoracotomy, it is generally preferred to insert the leads endovascularly into a chamber of the heart, when possible. In most single lead systems, the lead is passed through the superior vena cava, right atrium and tricuspid valve, and into the right ventricle. The electrode is fixed within the right ventricle usually at the apex position. In many multiple lead systems and some single lead systems, one lead is passed through the superior vena cava, right atrium and coronary sinus, generally with the aid of fluoroscopy, and fixed within the great vein or a deep coronary vein to locate the electrode in proximity to the left atrium or left ventricle.

[0005] Determining the location of the coronary sinus and placing a lead therein can be difficult. The lead must traverse an angle to enter the orifice of the coronary sinus in the wall of the right atrium. The difficulty of locating the coronary sinus and placing a lead therein is especially great in patients with congestive heart failure and dilated cardiomyopathy. In such patients, the heart is enlarged and the location of the coronary sinus can vary significantly from the location in a heart with normal anatomy. Nevertheless, the ongoing need to place endovascular cardiac leads in patients with an unusually disposed coronary sinus is expected to increase. This is because of the emerging use of implantable pulse generators to treat congestive heart failure.

[0006] Implantable pulse generators may be particularly useful for treating congestive heart failure ("CHF") manifested by conduction defects or other cardiomyopathies. In a healthy person, the electrical conduction system of the heart sends signals to the chambers of the heart that cause them to contract in a precise pattern to pump blood throughout the circulatory system. In people with congestive heart failure, however, the electrical conduction system is often impaired and fails to coordinate the contractions of the heart's chambers. In many patients with CHF, the left and right ventricles no longer contract in the usual synchronized manner. This can reduce cardiac output, leading to symptoms such as shortness of breath, fatigue, and swelling of the feet and ankles.

[0007] A promising therapy for treating congestive heart failure through the use of implantable pulse generators is bi-ventricular pacing, also known as cardiac resynchronization. By sensing and pacing the left and right ventricles separately, the desired timing of the contractions of the ventricles can be obtained. This will result in an increase in cardiac output.

[0008] Bi-ventricular pacing involves placement of right and left ventricular pacing leads. The procedure for placing a pacing lead within a right ventricle is well known and has been effectively practiced for decades. In contrast, it is not desirable to place a pacing lead within the left ventricle. A lead passing through the left atrium and mitral valve into the left ventricle could interfere with complete closure of the valve, thereby impairing the performance of the left ventricle in pumping oxygenated blood throughout the body. Also, pacing leads may be a site of clot formation. Such clots, if dislodged, may cause serious problems in the arterial circulation system, e.g., stroke. Pacing of the left ventricle can be achieved by placing a lead into a branch of the coronary sinus that overlies the left ventricle. As noted above, placing a left ventricular pacing lead into the coronary sinus can be extremely difficult even when performed by the most experienced electrophysiologists.

[0009] Preformed catheters have been used to permit access to the coronary sinus via the superior vena cava and right atrium. The use of such preformed catheters is complicated in patients with CHF and dilated cardiomy-

opathy because the location of the coronary sinus is quite variable. In recent clinical trials of bi-ventricular pacing, cannulation of the coronary sinus was attempted by experienced and expert electrophysiologists who cannulate the coronary sinus daily for arrhythmia testing. Despite their experience and expertise, the coronary sinus was successfully accessed only 85 percent of the time.

[0010] If bi-ventricular pacing is to become a widely used treatment for congestive heart failure, then reliable and easy access to the coronary sinus must be provided. There are insufficient numbers of experienced electrophysiologists to accommodate the demand for this therapy. The present invention permits cardiologists and others without daily experience accessing the coronary sinus to do so reliably. Other medical procedures that require endovascular access to the coronary sinus likewise will be facilitated by the present invention. An example of such a procedure is electrophysiologic testing when the coronary sinus is difficult to locate or cannulate.

[0011] US-A-6264627 discloses a catheter with an opening in a distal end thereof for ensuring correct position by blood sampling through the opening with measurement of oxygen saturation. After insertion of the catheter a guide wire is removed from a guide wire channel and a blood sample can be taken out through the opening and channel.

Summary of the Invention

[0012] The present invention is set out in Claim 1.

[0013] The present invention relates to the medical procedure of accessing the orifice of the coronary sinus for the purpose of placing a medical device adjacent to or through the orifice. One such medical device is a permanent left ventricular pacing lead. Other medical devices include temporary sensing or pacing catheters for electrophysiologic testing.

[0014] Locating the orifice of the coronary sinus involves sensing characteristics of blood emerging from the coronary sinus into the right atrium. One characteristic that is especially correlated with blood from the coronary sinus is oxygen content. The percent oxygen saturation in the coronary sinus is among the lowest in the human body. Other characteristics correlated with blood from the coronary sinus are lower pH and higher CO₂ concentration. By sensing the oxygen concentration, pH, CO₂ or other characteristic at the distal end of a medical device placed within the right atrium, and by steering the distal end of the medical device toward a region of lower oxygen concentration, lower pH or higher CO₂ concentration, for example, the location of the orifice of the coronary sinus can be determined. Once the orifice of the coronary sinus is located, the medical device can be introduced into the coronary sinus or used to establish a pathway for guiding another device into the coronary sinus. One such medical device is a left ventricular pacing lead.

[0015] The present invention also permits determina-

tion of oxygen saturations in other vascular structures. This may be particularly important in patients with congenital heart disease as well as in patients in whom specific organ venous and arterial oxygen saturations are needed to guide medical therapy.

[0016] According to another aspect of the invention, a steerable oximetric catheter includes an elongate cannula having a proximal end and a distal end. A blood oxygen sensor is connected to the cannula and is disposed to sense percent oxygen saturation of blood at the distal end of the cannula. The blood oxygen sensor generates a signal indicative of percent oxygen saturation. An oximetry display is responsive to the signal and is capable of displaying sensed percent oxygen saturation in a form understandable by an operator. A steering mechanism is operably connected to the cannula and selectively operable by an operator to deflect the distal end of the cannula toward a region of relatively low percent oxygen saturation.

[0017] Once the coronary sinus is located, a pacing lead can be inserted through the cannula to be fixed proximate to the coronary sinus or inserted into and fixed into the great vein or a coronary vein extending from the coronary sinus. The steerable catheter then can be removed. Alternatively, once the coronary sinus is located, a hollow sheath can be advanced over the steerable catheter and held at the coronary sinus. The steerable catheter then can be removed and the pacing lead can be inserted through the hollow sheath to have its distal end fixed in the coronary sinus or a coronary vein extending from it. The hollow sheath then can be removed.

[0018] Further aspects and advantages of the present invention are apparent from the following description of preferred embodiments and methods, made with reference to the drawings.

Brief Description of the Drawings

[0019] In the drawings,

FIGURE 1 is a partially cut-away view of a human heart in which a prior art pacing lead is implanted. The lead extends through the superior vena cava, right atrium, coronary sinus and a left coronary vein; FIGURE 2 is a plan view of an embodiment of a steerable, oximetric catheter of the present invention; FIGURE 3 is an enlarged view of a portion of the embodiment of FIGURE 2, shown cut-away; FIGURE 4 is an enlarged cross-sectional view of the embodiment of FIGURE 2; FIGURE 5 is a plan view of another embodiment of a steerable, oximetric catheter of the present invention; FIGURE 6 is an enlarged plan view of a portion of the embodiment of FIGURE 5; FIGURE 7 is a cut-away view of a human heart, showing placement of the steerable oximetric catheters of FIGURES 2-6;

FIGURE 8 is a cross-sectional view of the catheter of FIGURES 5 and 6;

FIGURE 9 is a cross-sectional view of an alternative embodiment of a steerable, oximetric catheter;

FIGURE 10 is a cross-sectional view of yet another alternative embodiment of a steerable, oximetric catheter; and

FIGURE 11 is a plan view of a kit for performing the placement of an endovascular lead.

Description of the Preferred Embodiments

[0020] FIGURE 1 shows a human heart H, partially cut away, in which an electrical pacing lead L is implanted. In accordance with the prior art, lead L has been placed endovascularly through the superior vena cava SVC and right atrium RA, and through the orifice of the coronary sinus OCS into the coronary sinus CS and into a left ventricular venous branch thereof. Pacing lead L includes at least one electrically insulated conductor extending lengthwise therethrough and at least one electrode E. Connector C at the proximal end of lead L is electrically connected via the insulated conductor to electrode E. A pulse generator P, usually implanted in a subcutaneous pocket in the chest wall of the patient, is connected to lead L via connector C. Because the left ventricular branches of the coronary sinus overly and are in physical proximity to the left ventricle LV, an electrical pulse can be delivered from pulse generator P via lead L and electrode E to stimulate contraction of the left ventricle. This lead arrangement is particularly suitable for pacing, cardioversion, or defibrillation of the left ventricle. Alternatively, with appropriate electrode placement, this lead arrangement can be used for sensing electrical activity in the vicinity of the left atrium or left ventricle, or for stimulating the left atrium. In combination with a second lead (not shown) disposed in the right ventricle RV, this lead arrangement can be used to effect bi-ventricular pacing for the treatment of congestive heart failure, as well as other medical conditions.

[0021] Placing a lead or other elongate medical device such as a catheter or cannula through the superior vena cava and right atrium into the orifice of the coronary sinus can be quite difficult, even with the use of fluoroscopy to monitor the location of the distal end of the medical device. The angles that the cannula must traverse are difficult to negotiate, even if the location of the orifice of the coronary sinus is generally known. In patients with distorted cardiac anatomy, such as that associated with congestive heart failure, the orifice of the coronary sinus can be more difficult to locate. An improved device and method for facilitating locating the coronary sinus is provided by the present invention, preferred embodiments of which are described below.

[0022] FIGURES 2, 3 and 4 show one embodiment of a steerable oximetric catheter 10.

[0023] Catheter 10 includes a steerable cannula 20, including a blood-contacting sheath 21 that is fabricated

from biocompatible polymers with low thrombogenicity. Radiopaque markers 22 may be placed along the length of the cannula 20 for fluoroscopic detection. Preferably encased within the sheath 21 of cannula 20 is a steering mechanism including a steerable guide 24, and a blood characteristic sensor such as a fiber optic oxygen sensor assembly 28. The steerable guide 24 and fiber optic oxygen sensor assembly 28 preferably run the entire length of cannula 20 to the distal end 32 and also extend from the proximal end 26 of cannula 20. The fiber optic oxygen sensor assembly 28 could be replaced by another sensor appropriate to other blood characteristics that are correlated with the blood of the coronary sinus, such as pH or CO₂ content.

[0024] Steerable guide 24 preferably includes an outer tube 25 and an internal wire 27 that runs from the distal end 32 to steering control module 30. Finger grips 34 and thumb grip 36 of control module 30 are reciprocally movable relative to each other along the axis of steerable guide 24. Thumb grip 36 is affixed to the outer tube 25 of guide 24 and finger grips 34 are affixed to the proximal end of the internal wire 27.

[0025] The distal end of the internal wire 27 is affixed to the distal end of the outer tube 25 of steerable guide 24 in an axially offset manner as is known in the art. Alternatively, the outer tube 25 can be eliminated and the internal wire 27 instead affixed directly to the sheath 21 of cannula 20, in which case the thumb grip 36 could be affixed to sheath 21 with finger grips 34 being affixed to wire 27. By pulling finger grips 34 toward thumb grip 36, the internal wire 27 is placed in tension, thereby deflecting the distal end of steering guide 24, and hence sheath 21 and cannula 20, to one side. Through a combination of deflecting the distal end of cannula 20 via grips 34 and 36, and rotating the entire catheter 10 about its longitudinal axis, likewise via grips 34 and 36, the distal end of catheter 10 can be steered anywhere within a 360 degree range. Other steering mechanisms as known in the art can also be used.

[0026] The preferred blood characteristic sensor uses fiber optics to sense oxygen content, but alternatively, pH or CO₂ sensors can be used. The preferred fiber optic assembly 28 includes a pair of optical fibers 29 and 31 encased in a tube 33. These fibers run the entire length of assembly 28 and are connected at their proximal end to a photodetector optical module 38. The distal ends of the optical fibers are exposed at the distal end of assembly 28, and hence at the distal end 32 of cannula 20. Alternatively, the tube 33 can be eliminated and the optical fibers 29 and 31 can be carried inside sheath 21, or the steering guide 25, or on the outside of the cannula 20. Optical module 38 includes a light source in optical communication with the proximal end of one of the optical fibers 29,31, and a photodetector in optical communication with the proximal end of the other of the optical fibers 29,31. Light from the light source travels the length of the one optical fiber and exits at the distal end thereof, thereby illuminating the blood in the vicinity of the distal end

32 of the catheter 10. Light is reflected from the blood into the exposed distal end of the other optical fiber and is carried the length of that optical fiber to the photodetector in optical module 38.

[0027] According to a well known phenomenon, the color of the blood is a function of the percentage of oxygen saturation of the blood. Consequently, the color of the light absorbed by the blood, and hence the color of the light reflected back to the optical module 38, is also a function of oxygen content of the blood. The photodetector in optical module 38 is differentially responsive to different wavelengths of light, and generates an electrical signal indicative of the wavelength of the reflected light received via the optical fiber. The generated signal can be conveyed via suitable conductors 39 to a processor and display module 41 that can process the signal and display the percentage oxygen saturation in a form that is directly readable by a human, such as a digital display. Alternatively, the signal could be conveyed to a computing device for further manipulation prior to being displayed in human-readable form. One example of such a system is Optical Oximeter Apparatus and Method, U.S. Patent No. 3,847,483.

[0028] Steerable oximetric catheter 10, which combines an oxygen sensing optical fiber assembly 28 with a wire-steerable guide 24 in a common cannula 20, is useful for locating the coronary sinus in accordance with the method of the present invention. The oxygen content of blood in the coronary sinus is known to be among the lowest in the human body. This phenomenon is exploited by the steerable oximetric catheter 10 to facilitate locating the coronary sinus. By monitoring the oxygen content or other characteristic of the blood in the vicinity of the distal end of catheter 10 in real time as catheter 10 is advanced through the right atrium, the operator can know whether the distal end of the catheter is either on or deviating from a path approaching the coronary sinus. If the sensed percentage of oxygen saturation continues to drop as catheter 10 is advanced, then the operator knows that the distal end of the catheter is getting closer to the coronary sinus. If the oxygen saturation begins to rise as the catheter is advanced, then the operator knows that the catheter is off course and he can correct the course using the steerability feature of the catheter. In effect, the operator is seeking to detect the low oxygen blood that exits from the coronary sinus into the right atrium. With an iterative procedure, the operator can make use of the percentage oxygen saturation being sensed in real time to guide and adjust his steering of the catheter to find the coronary sinus.

[0029] FIGURES 5 and 6 show an alternative embodiment of a steerable oximetric catheter 110 that is substantially similar to the embodiment of FIGURES 2, 3 and 4, except that the steering control module 130 is somewhat different. Components that correspond in structure and function to the components described above with respect to the embodiment of FIGURE 1 are indicated by similar reference numbers in the 100 series having

the last two digits in common. The description above may be referred to for an understanding of the corresponding components of the embodiment of FIGURES 5 and 6. Steering control module 130, rather than having members that reciprocate axially relative to one another, has grip members that rotate relative to one another. Grip portion 140, which loosely corresponds to finger grip portion 34, is held in the operator's hand, while steering member 142 is gripped and rotated relative to grip portion 140. Steering member 142 is connected to the internal steering wire, whereas grip portion 140 is connected to the outer cannula of the steering guide 124. Rotation of member 142 relative to portion 140 places the steering wire in tension, effecting deflection of the distal end 132 of cannula 120. A locking lever 144 locks the steering member 142 in a selected position to maintain a selected deflection of the distal end 132 of cannula 120. Steering control module 130 is shown enlarged in FIGURE 6 for clarity.

[0030] With the above description of preferred embodiments of steerable oximetric catheters in mind, the preferred procedures for practicing a method for locating the coronary sinus will be described with reference to FIGURE 7. In brief summary, a hollow, flexible, peel-away sheath 43 can be placed over the cannula 20 of catheter 10, for example, and slid to a position near proximal end 26. Cannula 20, with the peel-away sheath in place, can be introduced endovascularly under fluoroscopy through the superior vena cava 50 and into the right atrium 52. Using the steering mechanism in concert with the oximetry sensor of catheter 10, the coronary sinus 54 is located and the distal end of cannula 20 is steered into coronary sinus 54. Once the steerable catheter 10 is in the coronary sinus 54, the hollow, flexible peel-away sheath 43 can be slid distally over the cannula 20 toward distal end 32, guided into the coronary sinus 54, and held there. The steerable catheter 10 then can be withdrawn and removed, leaving the sheath 43 in place. Subsequently, a ventricular pacing lead can be advanced through the sheath 43 into the coronary sinus and placed into one of the coronary veins 56 associated with the left ventricle 58. The sheath 43 then can be withdrawn and peeled away from the lead.

[0031] Instead of using a sheath, the cannula 220 can be hollow defining a lumen 262 along its length according to the invention and as shown in cross section in FIGURE 8. After the coronary sinus is located, the pacing lead is introduced through the lumen 262 and into one of the coronary veins 56. This system has the advantage of eliminating the use of the sheath, but does require that the cannula be large enough to carry the pacing lead.

[0032] Alternatively, the cannula 320 can be hollow defining a lumen 362 along its length, similarly to the cannula 220 of FIGURE 8, but not including an embedded steering mechanism, as shown in FIGURE 9. In use, a steering mechanism such as the steerable guide 24 of FIGURES 2, 3 and 4 could be inserted within the lumen 362 and used to steer the cannula 320. After the coronary

sinus is located, the steering mechanism could be withdrawn from lumen 362, leaving lumen 362 open. The pacing lead could then be introduced through open lumen 362 and into the coronary sinus and great vein.

[0033] In yet another alternative arrangement, the cannula 420 can include a steering mechanism 427, optical fibers 429 and 431, and a pacing lead 464 embedded or otherwise disposed therein, as shown in FIGURE 10. After the coronary sinus is located, the cannula 420 and lead 464 can be advanced as a unit into the coronary sinus and great vein. The proximal end of the cannula 420 can be cut off, or otherwise separated from the bulky steering controls and optical module. The pacing lead 464, including cannula 420, steering wire 427 and optical fibers 429 and 431 can be left permanently implanted as a unit.

[0034] In lieu of a sheath, a guidewire could be used to guide a hollow lead into the coronary sinus, with the lead riding over the guidewire instead of riding inside a sheath.

[0035] To place the steerable oximetric catheter 10 into the coronary sinus, the patient is placed upon a fluoroscopy table in a cardiac catheterization laboratory or in an operating room. Through a typical pacemaker incision below the clavicle, the subclavian vein or cephalic vein is accessed and cannulated with a hollow, flexible tube. The steerable, oximetric catheter 10 is placed through the hollow, flexible tube and into the superior vena cava, then advanced into the right atrium. The distal end of the oximetric assembly 28 is then connected to the optical module 38, which is connected to its associated processor and display 41. A right atrial baseline oxygen saturation is obtained.

[0036] Fluoroscopic evaluation of the end 32 of catheter 10 will permit the operator to estimate the approximate region in which the coronary sinus is located. The steerable, oximetric catheter 10 may then be advanced under fluoroscopy while percentage oxygen saturation is monitored. Any changes in oxygen saturation are noted. As the catheter 10 nears the coronary sinus orifice, the sensed oxygen saturation will drop. Using the steerable feature of the catheter, the site of the lowest oxygen saturation can be sought. The operator can continue to advance the steerable, oximetric catheter 10 under fluoroscopy and oximetric guidance into and through the coronary sinus orifice and into the coronary sinus. By monitoring the percentage oxygen saturation as the catheter is advanced, the operator may place the catheter 10 into the coronary sinus despite difficult angulations related to unusual physiology of the patient. Such difficulties could not be so easily overcome with fluoroscopic guidance alone.

[0037] The utility of the catheter of the present invention was demonstrated in an experiment involving an adult swine. A steerable, oximetric catheter was successfully placed into the coronary sinus of a pig. Conventional general endotracheal anesthesia was employed. The pig was placed in the decubitus position with the left side

down. A right internal jugular cutdown was performed to access the central venous system. A prototype steerable oximetric catheter was created by attaching an Edwards central venous line with oximetry capability to a Blazer II model steerable catheter from EP Technologies. An in-vitro calibration of the oximetry probe was performed successfully. The prototype catheter was then introduced through the jugular vein into the superior vena cava and right atrium. Under fluoroscopy, the prototype catheter was placed into the coronary sinus using oximetric guidance. When the prototype catheter was placed in the coronary sinus, the percentage oxygen saturation dropped from the sixty percent range to the mid-thirty percent range. After verifying placement, the prototype was withdrawn into the right atrium. Again, under fluoroscopy, the prototype catheter was steered into the coronary sinus under oximetric guidance. Following successful coronary sinus cannulation, the prototype catheter was withdrawn and the pig euthanized.

[0038] A kit for performing the placement of a pacing lead is shown in FIGURE 11. The kit includes a steerable oximetric catheter 310 and a sheath 270 in a sterile container 272. The kit can also include one or more of the following: catheter, sheath, syringe, large needle, dilator or a floppy wire, e.g., having a diameter of about 0.018 inches.

Claims

1. A steerable catheter (10) comprising:

an elongate cannula (20) comprising a tubular wall having a proximal end and a distal end;
a steering mechanism operably connected to the cannula and selectively operable by an operator to steer the distal end of the cannula;
characterised by blood characteristic sensor (28) connected to the cannula and disposed at the distal end thereof to sense a blood characteristic at the distal end of the cannula for locating the coronary sinus;
the tubular wall defining an open passageway sized to receive a pacing lead therein for placing the pacing lead in the coronary sinus.

2. The steerable catheter of Claim 1, wherein the blood characteristic sensor (28) is a blood oxygen sensor, a pH sensor, or a carbon dioxide sensor, and the blood characteristic is oxygen concentration, pH, or carbon dioxide concentration, respectively.

3. The catheter of Claims 1 or 2, wherein the blood characteristic sensor (28) includes at least one pair of optical fibers (29, 31) within the cannula (20) extending from the distal end to the proximal end of the elongate cannula wherein each fiber (29, 31) has a distal end disposed at the distal end of the catheter

- and a proximal end optically coupled to an optical module (38), the distal end of one fiber being adapted to illuminate blood present at the distal end (32) of the catheter with light generated by the optical module, and the distal end of the other fiber being adapted to transmit light reflected from the illuminated blood to the optical module; the optical module being adapted to determine a blood oxygen level from the reflected light.
4. The catheter of Claim 3, wherein the pair of optical fibers (29, 31) are disposed within the tubular wall of the cannula (20) and have distal ends optically exposed and affixed at the distal end of the elongate cannula.
5. The catheter of Claims 1, 2, 3, or 4 wherein the steering mechanism includes a wire (27) extending from the distal end to the proximal end of the elongate cannula (20).
6. The catheter of Claim 5 wherein the wire (27) is affixed to the elongate cannula (20) proximate the distal end thereof.
7. The catheter of Claims 5 or 6, wherein the steering mechanism includes a steering control module (30) affixed to the wire (27) and manipulable by an operator.
8. The catheter of Claims 5, 6 or 7 wherein the wire (27) is disposed within the passageway defined by the tubular wall.
9. The steerable catheter of any one of Claims 5 to 8 wherein the steering mechanism further comprises a finger grip portion (34) attached to the proximal end of the wire (27); and a thumb grip (35) operably connected to the cannula (20); wherein the thumb grip is movable relative to the finger grip portion in a direction defined by the wire such that when the thumb grip is moved toward the finger grip portion the wire is placed in tension and deflects the distal end of the cannular.
10. The steerable catheter of Claim 9 wherein the steering mechanism further comprises a steerable guide (24) with a distal end and a proximal end, wherein the proximal end of the steerable guide is affixed to the thumb grip (36); the distal end of the wire (27) affixed to the cannula (20) by the steerable guide (24).
11. The steerable catheter of Claim 10 wherein the steerable guide (24) is an elongate tube (25) defining a lumen, and is disposed within the passageway of the cannula (20).
12. The steerable catheter of Claim 11, wherein the steerable guide (24) has a longitudinal axis, the wire (27) is contained within the lumen of the steerable guide (24) and the wire is radially offset from the longitudinal axis of the steerable guide (24).
13. The steerable catheter of Claim 9 when dependent upon Claim 5, wherein the thumb grip (36) is affixed to the proximal end of the cannula (20) and the wire (27) is affixed to the distal end of the cannula.
14. The steerable catheter of Claim 3 or any preceding claim when dependent upon Claim 3, wherein the optical module (38) is differentially responsive to different wavelengths of light and generates an electrical signal indicative of the wavelength of the reflected light received via the optical fiber.

20 Patentansprüche

1. Steuerbarer Katheter (10), aufweisend:

eine eine rohrförmige Wand aufweisende längliche Kanüle (20) mit einem proximalen Ende und einem distalen Ende;

einen Steuerungsmechanismus, der funktionell mit der Kanüle verbunden ist und selektiv durch eine Bedienungsperson betätigt werden kann, um das distale Ende der Kanüle zu steuern;

gekennzeichnet durch einen Bluteigenschaftssensor (28), der mit der Kanüle verbunden und an deren distalem Ende angeordnet ist, um eine Bluteigenschaft an dem distalen Ende der Kanüle zur Lokalisierung des Koronarsinus zu messen;

wobei die rohrförmige Wand einen offenen Kanal definiert, der für die Aufnahme eines Schrittmacherleiters darin zum Platzieren des Schrittmacherleiters in dem Koronarsinus bemessen ist.

2. Steuerbarer Katheter des Anspruchs 1, wobei der Bluteigenschaftssensor (28) ein Blutsauerstoffsensor, ein pH-Sensor, oder ein Kohlendioxidsensor ist, und die Bluteigenschaft Sauerstoffkonzentration, pH bzw. Kohlendioxidkonzentration ist.

3. Katheter der Ansprüche 1 oder 2, wobei der Bluteigenschaftssensor (28) wenigstens ein Paar optischer Fasern (29, 31) in der Kanüle (20) enthält, die sich von dem distalen Ende zu dem proximalen Ende der länglichen Kanüle erstrecken, wobei jede Faser (29, 31) ein an dem distalen Ende des Katheters angeordnetes distales Ende und ein optisch mit einem optischen Modul (38) gekoppeltes proximales Ende besitzt, wobei das distale Ende der einen Faser dafür angepasst ist, an dem distalen Ende (32) des

- Katheters vorhandenes Blut mit von dem optischen Modul erzeugten Licht zu beleuchten, und das distale Ende der anderen Faser dafür angepasst ist, von dem beleuchteten Blut reflektiertes Licht an das optische Modul zu übertragen; wobei das optische Modul dafür angepasst ist, einen Blutsauerstoffgehalt aus dem reflektierten Licht zu bestimmen.
4. Katheter des Anspruchs 3, wobei das Paar der optischen Fasern (29, 31) in der rohrförmigen Wand der Kanüle (20) angeordnet ist, und distale Enden besitzen, die optisch freiliegen und an dem distalen Ende der länglichen Kanüle befestigt sind.
5. Katheter der Ansprüche 1, 2, 3 oder 4, wobei der Steuerungsmechanismus einen Draht (27) enthält, der sich von dem distalen Ende zu dem proximalen Ende der länglichen Kanüle (20) erstreckt.
6. Katheter des Anspruchs 5, wobei der Draht (27) an der länglichen Kanüle (20) in der Nähe ihres distalen Endes befestigt ist.
7. Katheter der Ansprüche 5 oder 6, wobei der Steuerungsmechanismus ein Steuerungskontrollmodul (30) enthält, das an dem Draht (27) befestigt ist und von einer Bedienungsperson manipuliert werden kann.
8. Katheter der Ansprüche 5, 6 oder 7, wobei der Draht (27) in dem durch die rohrförmige Wand definierten Kanal angeordnet ist.
9. Steuerbarer Katheter eines der Ansprüche 5 bis 8, wobei der Steuerungsmechanismus ferner einen Fingergriffbereich (34) aufweist, der an dem proximalen Ende des Drahtes (27) angebracht ist; und einen Daumengriff (35), der funktionell mit der Kanüle (20) verbunden ist; wobei der Daumengriff in Bezug auf den Fingergriffbereich in einer durch den Draht definierten Richtung dergestalt bewegt werden kann, dass, wenn der Daumengriff zu dem Fingergriffbereich hin bewegt wird, der Draht unter Zugspannung gesetzt wird und das distale Ende der Kanüle auslenkt.
10. Steuerbarer Katheter des Anspruchs 9, wobei der Steuerungsmechanismus ferner eine steuerbare Führung (24) mit einem distalen Ende und einem proximalen Ende aufweist, wobei das proximale Ende der steuerbaren Führung an dem Daumengriff (36) befestigt ist, während das distale Ende des Drahtes (27) an der Kanüle (20) durch die steuerbare Führung (24) befestigt ist.
11. Steuerbarer Katheter des Anspruchs 10, wobei die steuerbare Führung (24) ein ein Lumen definierendes längliches Rohr (25) ist und in dem Kanal der Kanüle (20) angeordnet ist.
12. Steuerbarer Katheter des Anspruchs 11, wobei die steuerbare Führung (24) eine Längsachse hat, der Draht (27) in dem Lumen der steuerbaren Führung (24) enthalten und der Draht radial aus der Längsachse der steuerbaren Führung (24) versetzt ist.
13. Steuerbarer Katheter des Anspruchs 9, wenn abhängig vom Anspruch 5, wobei der Daumengriff (36) an dem proximalen Ende der Kanüle (20) befestigt ist und der Draht (27) an dem distalen Ende der Kanüle befestigt ist.
14. Steuerbarer Katheter des Anspruchs 3 oder jedes vorstehenden Anspruchs, wenn abhängig vom Anspruch 3, wobei das optische Modul (38) unterschiedlich auf unterschiedliche Wellenlängen von Licht reagiert und ein elektrisches Signal erzeugt, das die Wellenlänge des über die optische Faser empfangenen reflektierten Lichtes anzeigt.

Revendications

1. Cathéter orientable (10) comprenant :

une canule de forme allongée (20) comprenant une paroi tubulaire présentant une extrémité proximale et une extrémité distale ;
 un mécanisme orientable relié de manière fonctionnelle à la canule et pouvant être actionné de manière sélective par un opérateur afin d'orienter l'extrémité distale de la canule ;
caractérisé par un détecteur des caractéristiques sanguines (28) connecté à la canule et disposé au niveau de l'extrémité distale de cette dernière afin de détecter une caractéristique du sang au niveau de l'extrémité distale de la canule afin de localiser le sinus coronaire ;
 la paroi tubulaire définissant une voie de passage ouverte dont la taille permet d'y recevoir une électrode de stimulation afin de placer l'électrode de stimulation dans le sinus coronaire.

2. Cathéter orientable de la revendication 1, dans lequel le détecteur des caractéristiques sanguines (28) est un détecteur d'oxygène dans le sang, un détecteur de pH, ou un détecteur de dioxyde de carbone, et la caractéristique sanguine est la concentration en oxygène, le pH, ou la concentration en dioxyde de carbone, respectivement.
3. Cathéter des revendications 1 ou 2, dans lequel le détecteur de caractéristiques sanguines (28) inclut au moins une paire de fibres optiques (29, 31) à l'intérieur de la canule (20) s'étendant depuis l'extrémité distale jusqu'à l'extrémité proximale de la canule al-

- longée dans laquelle chaque fibre (29, 31) présente une extrémité distale disposée au niveau de l'extrémité distale du cathéter et une extrémité proximale optiquement couplée à un module optique (38), l'extrémité distale d'une fibre étant adaptée pour éclairer le sang présent au niveau de l'extrémité distale (32) du cathéter avec de la lumière générée par le module optique, et l'extrémité distale de l'autre fibre étant adaptée pour transmettre la lumière réfléchie par le sang éclairé vers le module optique ; le module optique étant adapté pour déterminer un niveau d'oxygène dans le sang à partir de la lumière réfléchie.
4. Cathéter de la revendication 3, dans lequel la paire de fibres optiques (29, 31) est disposée à l'intérieur de la paroi tubulaire de la canule (20) et présente des extrémités distales optiquement exposées et fixées au niveau de l'extrémité distale de la canule allongée.
5. Cathéter des revendications 1, 2, 3 ou 4, dans lequel le mécanisme d'orientation inclut un fil métallique (27) s'étendant depuis l'extrémité distale jusqu'à l'extrémité proximale de la canule allongée (20).
6. Cathéter de la revendication 5, dans lequel le fil métallique (27) est relié à la canule allongée (20) à proximité de l'extrémité distale de cette dernière.
7. Cathéter des revendications 5 ou 6, dans lequel le mécanisme d'orientation inclut un module de commande de l'orientation (30) relié au fil métallique (27) et pouvant être actionné par un opérateur.
8. Cathéter des revendications 5, 6 ou 7, dans lequel le fil métallique (27) est disposé à l'intérieur de la voie de passage définie par la paroi tubulaire.
9. Cathéter orientable de l'une quelconque des revendications 5 à 8, dans lequel le mécanisme d'orientation comprend en outre une partie de préhension pour les doigts (34) fixée à l'extrémité proximale du fil métallique (27) ; et une prise pour le pouce (35) connectée de manière fonctionnelle à la canule (20) ; dans lequel la prise pour le pouce peut être déplacée par rapport à la partie de préhension pour les doigts dans une direction définie par le fil métallique de sorte que lorsque la prise pour le pouce est déplacée vers la partie de préhension pour les doigts le fil métallique est mis en tension et dévie l'extrémité distale de la canule.
10. Cathéter orientable de la revendication 9, dans lequel le mécanisme d'orientation comprend en outre un guide orientable (24) doté d'une extrémité distale et d'une extrémité proximale, dans lequel l'extrémité proximale du guide orientable est reliée à la prise pour le pouce (36) ; l'extrémité distale du fil mécanique (27) est reliée à la canule (20) par le guide orientable (24).
11. Cathéter orientable de la revendication 10, dans lequel le guide orientable (24) est un tube de forme allongée (25) définissant une lumière, et est disposé à l'intérieur de la voie de passage de la canule (20).
12. Cathéter orientable de la revendication 11, dans lequel le guide orientable (24) présente un axe longitudinal, le fil métallique (27) est contenu à l'intérieur de la lumière du guide orientable (24) et le fil métallique est radialement décalé par rapport à l'axe longitudinal du guide orientable (24).
13. Cathéter orientable de la revendication 9 lorsqu'elle est dépendante de la revendication 5, dans lequel la prise pour le pouce (36) est reliée à l'extrémité proximale de la canule (20) et le fil métallique (27) est relié à l'extrémité distale de la canule.
14. Cathéter orientable de la revendication 3, ou de l'une quelconque des revendications précédentes lorsqu'elles dépendent de la revendication 3, dans lequel le module optique (38) répond différemment à différentes longueurs d'onde de lumière et génère un signal électrique représentatif de la longueur d'onde de la lumière réfléchie reçue par l'intermédiaire de la fibre optique.

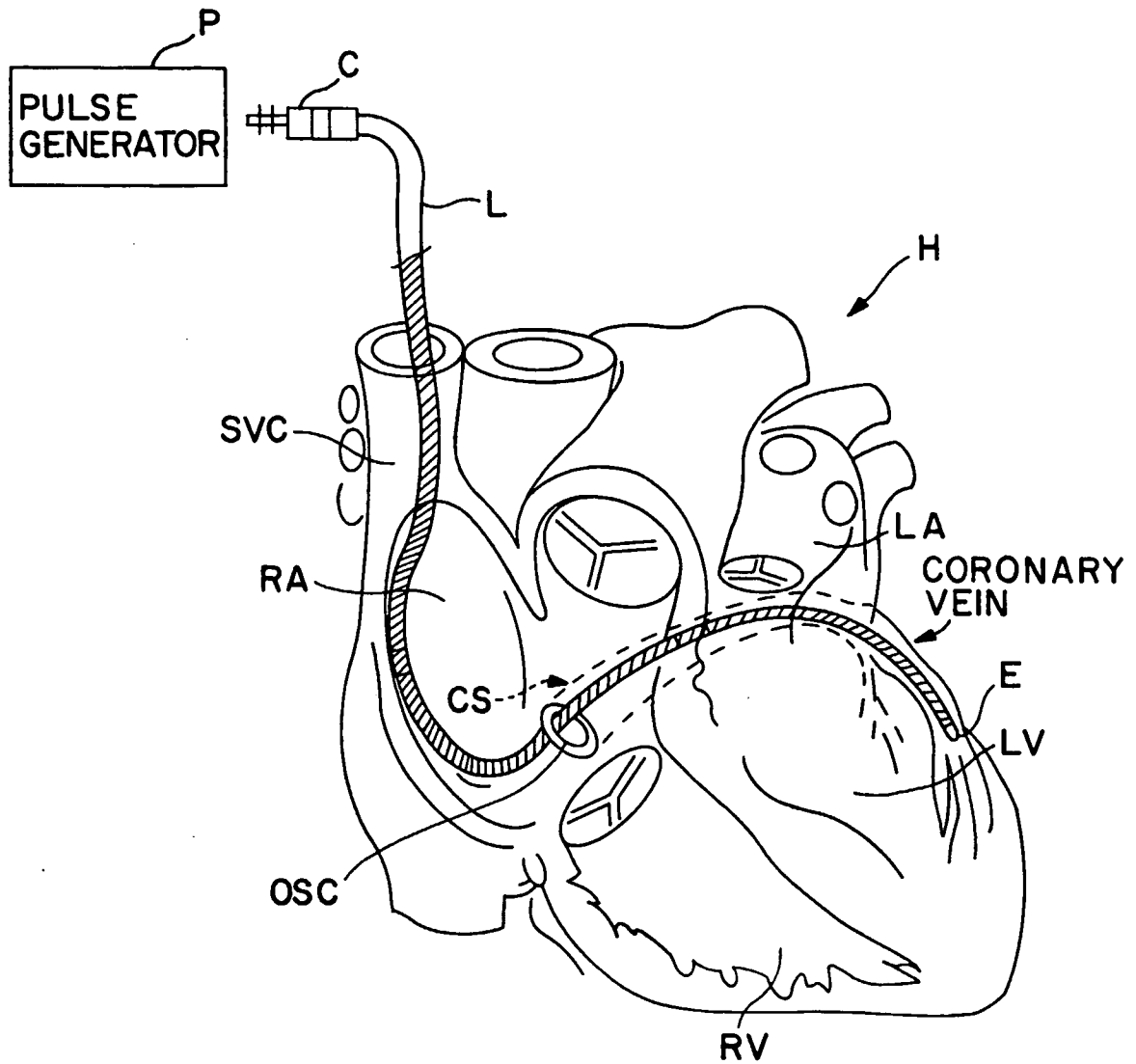

FIG. 1
PRIOR ART

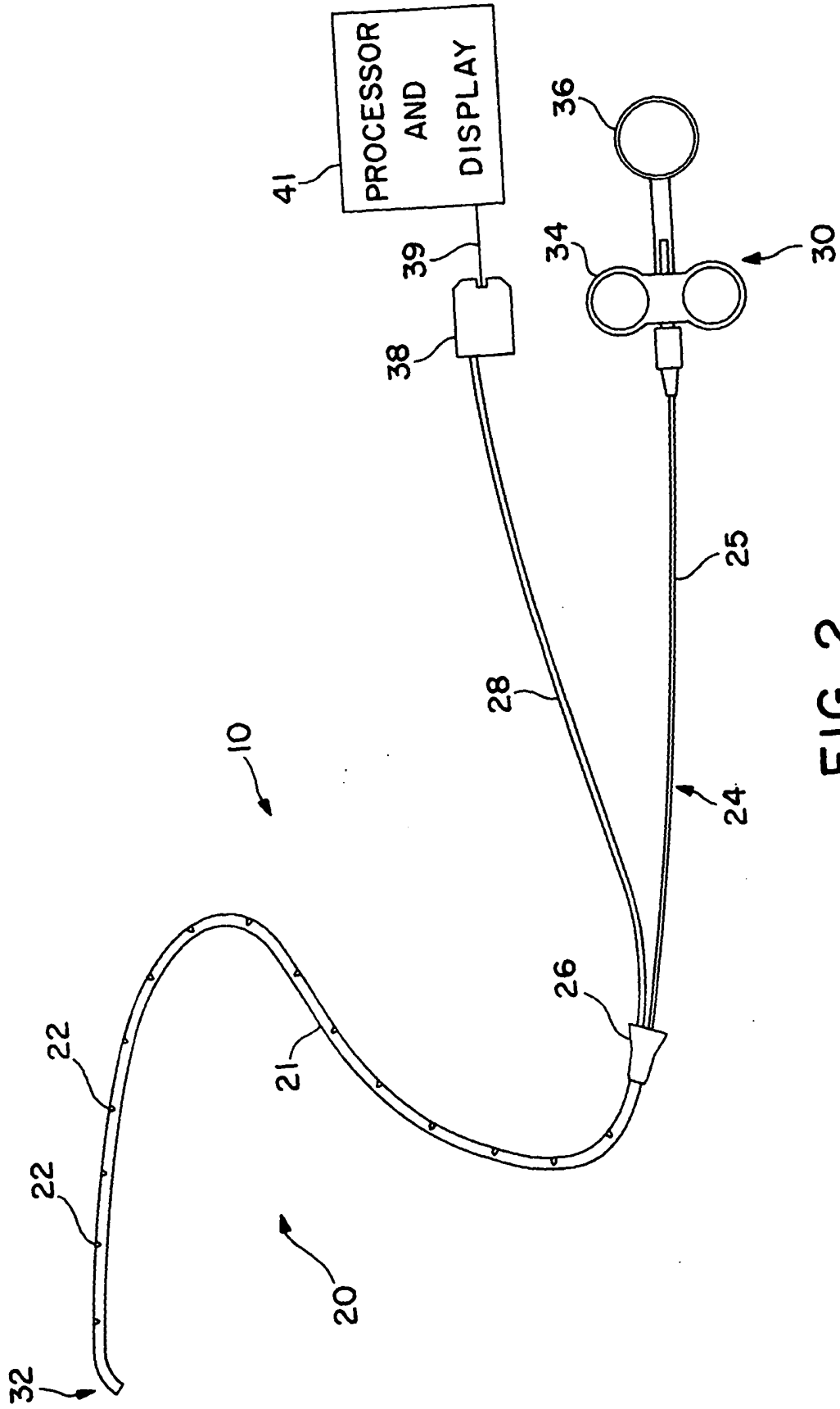

FIG. 2

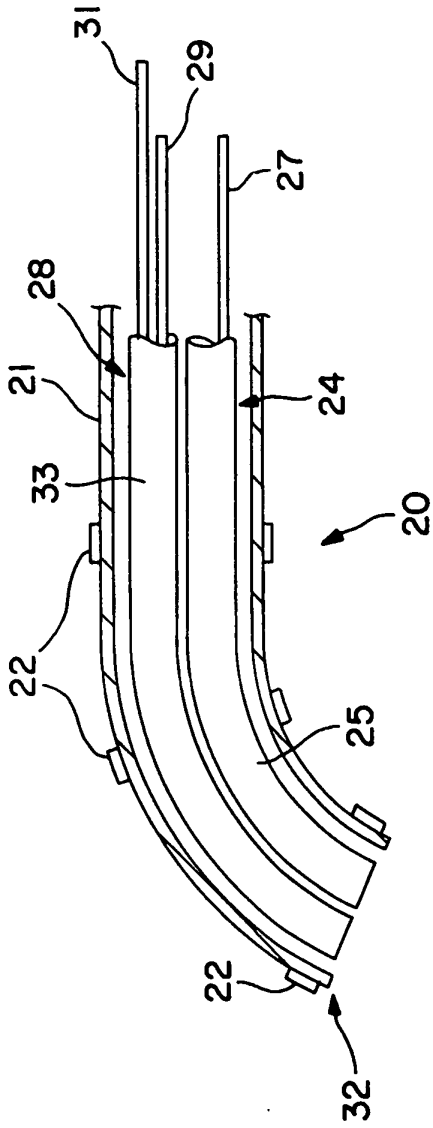

FIG. 3

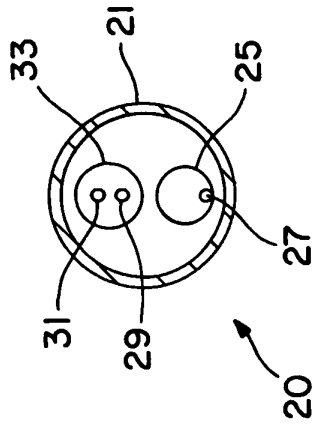

FIG. 4

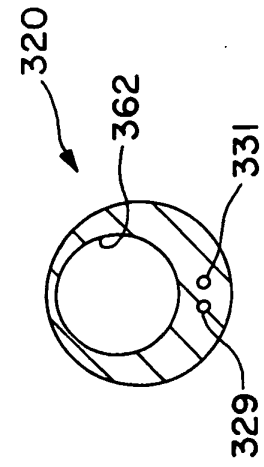

FIG. 9

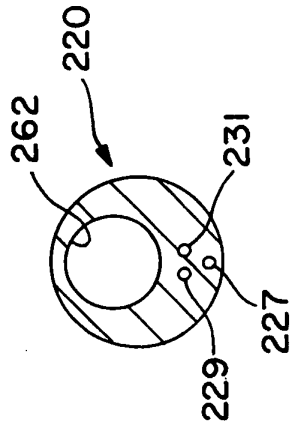

FIG. 8

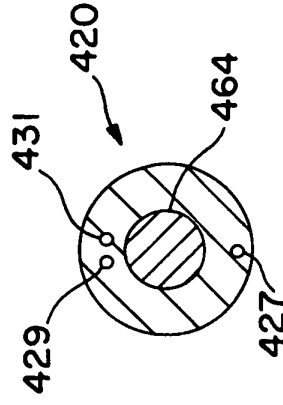

FIG. 10

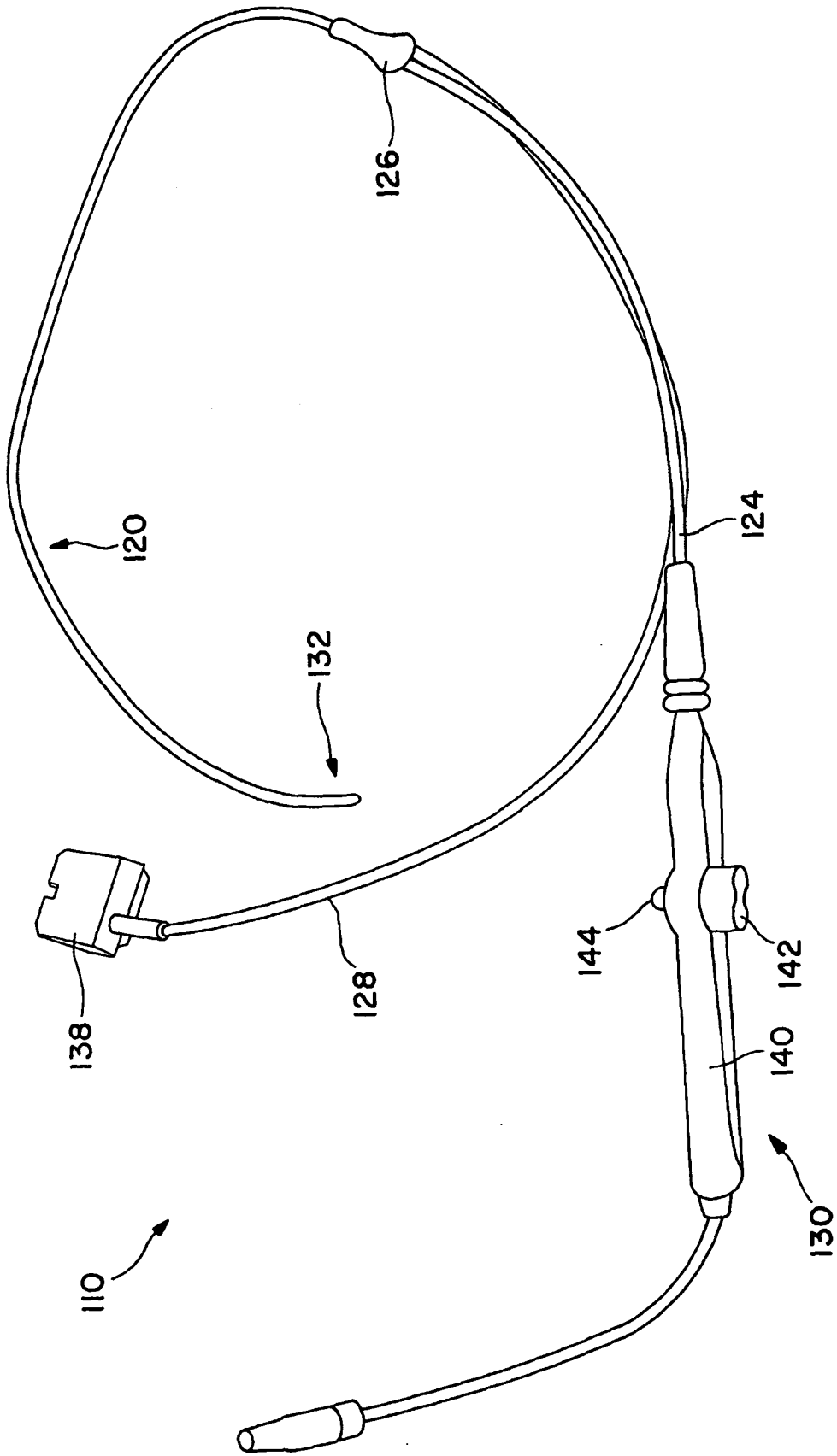

FIG. 5

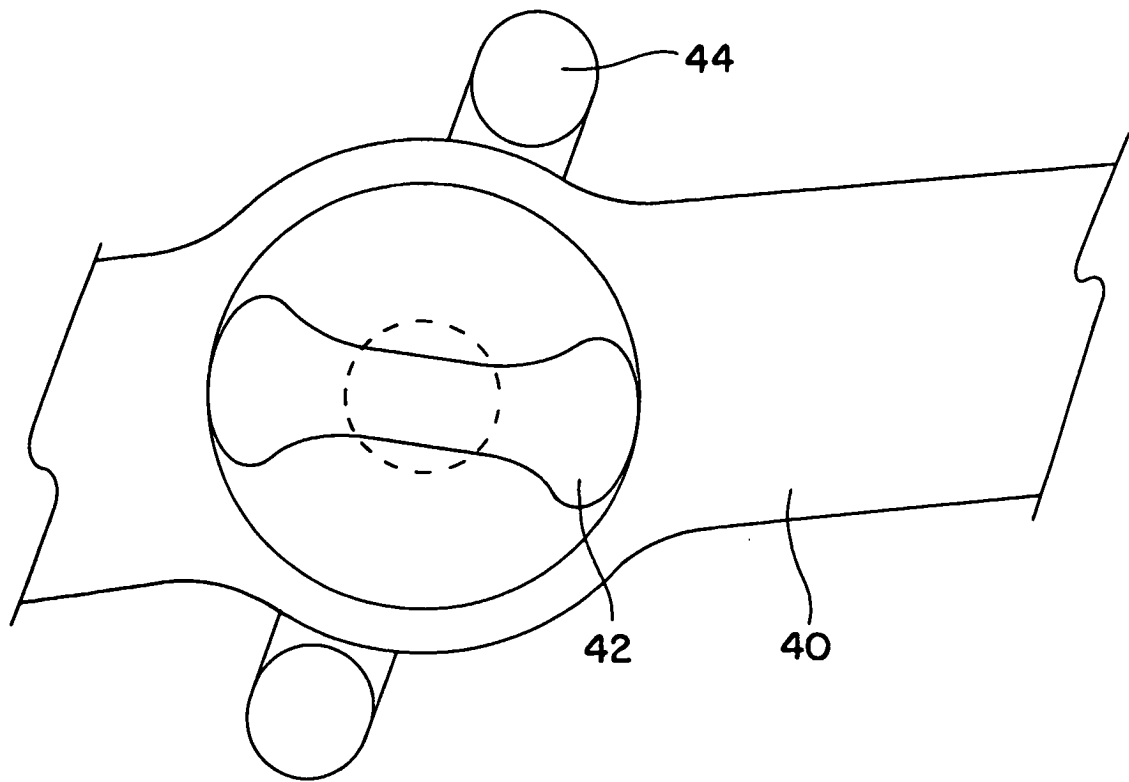

FIG. 6

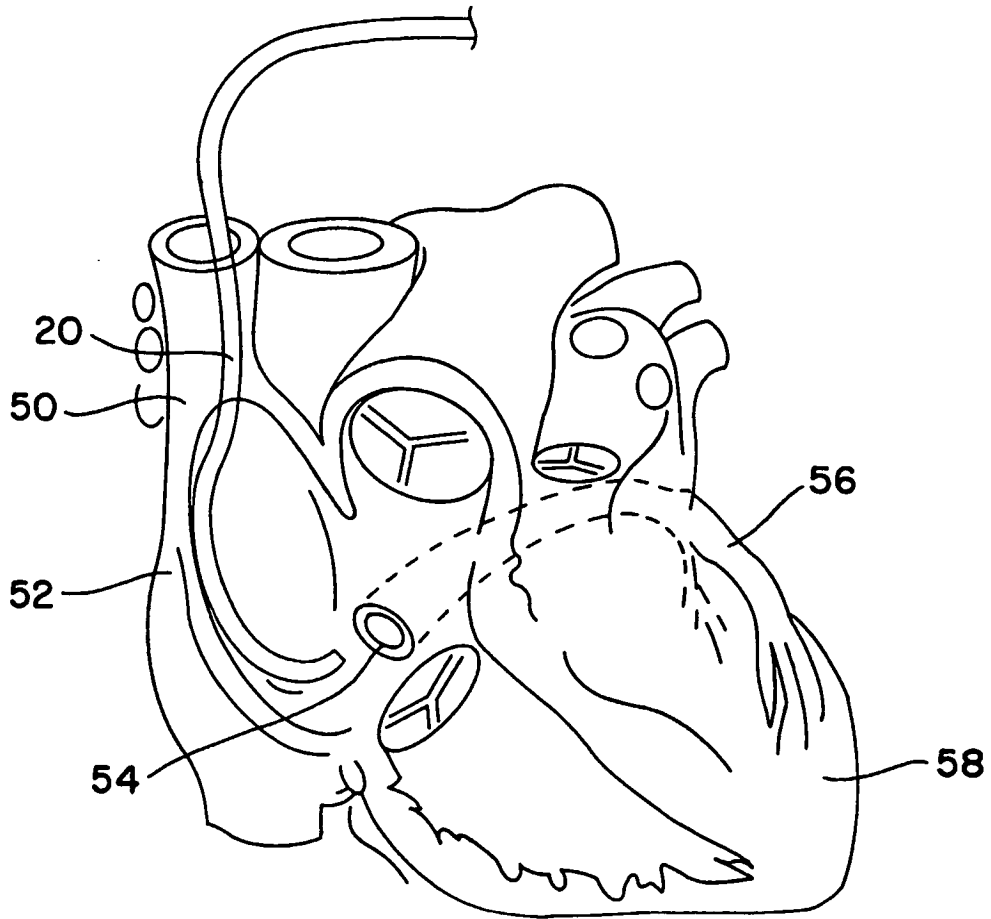

FIG. 7

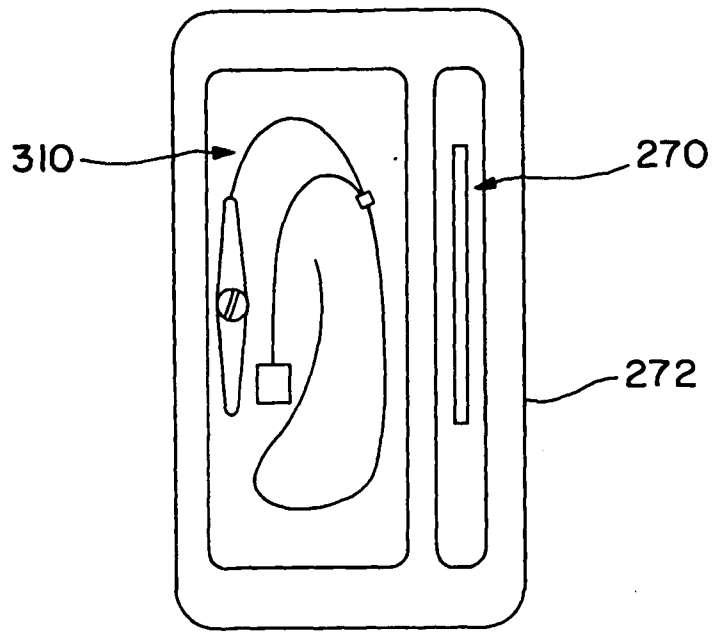

FIG. II

REFERENCES CITED IN THE DESCRIPTION

This list of references cited by the applicant is for the reader's convenience only. It does not form part of the European patent document. Even though great care has been taken in compiling the references, errors or omissions cannot be excluded and the EPO disclaims all liability in this regard.

Patent documents cited in the description

- US 5265601 A [0003]
- US 5902324 A [0003]
- US 6223079 B [0003]
- US 6122545 A [0003]
- US 6264627 A [0011]
- US 3847483 A [0027]

专利名称(译)	可操纵的导管和用于定位冠状窦的方法		
公开(公告)号	EP1455889A4	公开(公告)日	2006-05-17
申请号	EP2002795535	申请日	2002-10-18
申请(专利权)人(译)	杜兰教育基金的管理者		
当前申请(专利权)人(译)	杜兰教育基金的管理者		
[标]发明人	PIGOTT JOHN D		
发明人	PIGOTT, JOHN, D.		
IPC分类号	A61N1/00 A61B5/00 A61B17/00 A61M A61N1/05 A61N1/08 A61N1/365		
CPC分类号	A61B5/14539 A61B5/1459 A61B2017/003 A61N1/056 A61N2001/0585		
其他公开文献	EP1455889B1 EP1455889A2		
外部链接	Espacenet		

摘要(译)

可操纵的导管包括具有近端和远端的细长套管。诸如氧气传感器的血液特性传感器连接到套管，并且被布置为感测在套管的远端处的血液的氧饱和和百分比。血氧传感器产生指示氧饱和和百分比的信号。血氧饱和度显示器响应该信号，并能够以操作员可以理解的形式显示感测到的氧饱和和百分比。转向机构可操作地连接到套管，并且可由操作员选择性地操作以使套管的远端偏转。一种定位心脏的冠状窦的方法包括在血管内将导管引入右心房，感测导管远端的氧饱和度百分比，并将导管转向氧饱和和度最低的区域。

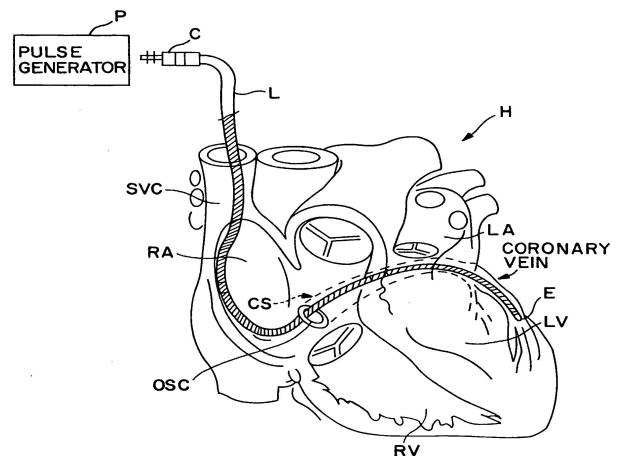

FIG. 1
PRIOR ART