



- (51) International Patent Classification:
A61B 5/00 (2006.01) A61B 5/024 (2006.01)
- (21) International Application Number:
PCT/US2014/057505
- (22) International Filing Date:
25 September 2014 (25.09.2014)
- (25) Filing Language: English
- (26) Publication Language: English
- (30) Priority Data:
61/882,403 25 September 2013 (25.09.2013) US
14/080,725 14 November 2013 (14.11.2013) US
14/080,717 14 November 2013 (14.11.2013) US
14/082,071 15 November 2013 (15.11.2013) US
14/217,402 17 March 2014 (17.03.2014) US
- (71) Applicant: **BARDY DIAGNOSTICS, INC.** [US/US];
17141 Vashon Highway SW, Vashon, Washington 98070 (US).

- (72) Inventors: **BARDY, Gust H.**; 29216 NE 52nd Street, Carnation, Washington 98014 (US). **FELIX, Jason**; P.O. Box 1053, Vashon Island, Washington 98070 (US). **BISHAY, Jon Mikalson**; 1824 5th Avenue West, Seattle, Washington 98119 (US).
- (74) Agents: **KISSELEV, Leonid** et al.; Suite 501, 12360 Lake City Way NE, Seattle, Washington 98125 (US).
- (81) Designated States (unless otherwise indicated, for every kind of national protection available): AE, AG, AL, AM, AO, AT, AU, AZ, BA, BB, BG, BH, BN, BR, BW, BY, BZ, CA, CH, CL, CN, CO, CR, CU, CZ, DE, DK, DM, DO, DZ, EC, EE, EG, ES, FI, GB, GD, GE, GH, GM, GT, HN, HR, HU, ID, IL, IN, IR, IS, JP, KE, KG, KN, KP, KR, KZ, LA, LC, LK, LR, LS, LU, LY, MA, MD, ME, MG, MK, MN, MW, MX, MY, MZ, NA, NG, NI, NO, NZ, OM, PA, PE, PG, PH, PL, PT, QA, RO, RS, RU, RW, SA, SC, SD, SE, SG, SK, SL, SM, ST, SV, SY, TH, TJ, TM, TN, TR, TT, TZ, UA, UG, US, UZ, VC, VN, ZA, ZM, ZW.
- (84) Designated States (unless otherwise indicated, for every kind of regional protection available): ARIPO (BW, GH,

[Continued on next page]

(54) Title: PROVIDING A PERSONAL MOBILE DEVICE-TRIGGERED MEDICAL INTERVENTION

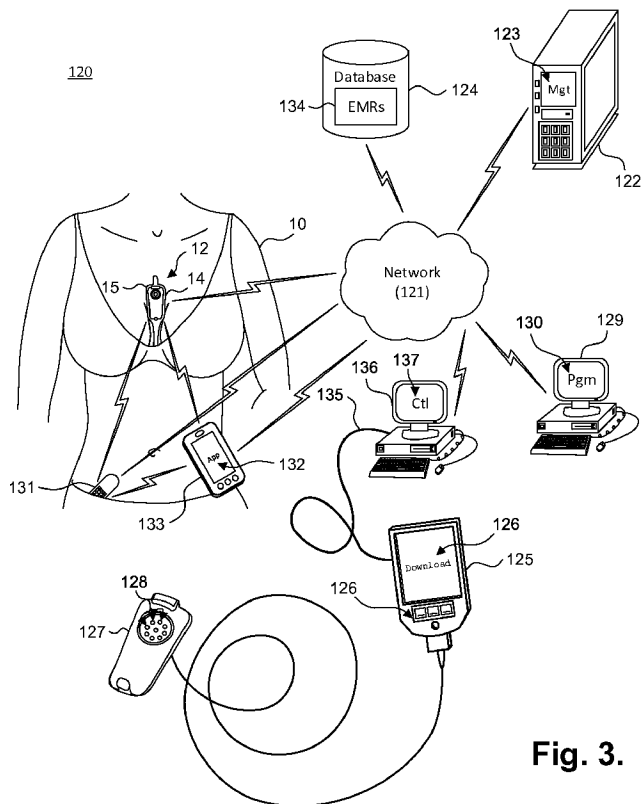

Fig. 3.

(57) Abstract: Physiological monitoring can be provided through a wearable monitor (12) that includes two components, a flexible extended wear electrode patch (15) and a removable reusable monitor recorder (14). The placement of the monitor (12) in a location at the sternal midline (16) (or immediately to either side of the sternum) benefits extended wear by removing the requirement that ECG electrodes be continually placed in the same spots throughout the monitoring. The monitor (12) can interoperate wirelessly with other physiology and activity sensors (131) and mobile devices (132). An application (132) executed by the sensor (131) or device (133) can trigger the dispatch of a wearable monitor (12) to the patient upon detecting potentially medically-significant events. The monitor (12) would then be capable of providing precise medically-actionable data. The patient (10, 11) can then use the sensor (131) or device (133) to record the placement and use of the monitor (12).

GM, KE, LR, LS, MW, MZ, NA, RW, SD, SL, ST, SZ,
TZ, UG, ZM, ZW), Eurasian (AM, AZ, BY, KG, KZ, RU,
TJ, TM), European (AL, AT, BE, BG, CH, CY, CZ, DE,
DK, EE, ES, FI, FR, GB, GR, HR, HU, IE, IS, IT, LT,
LU, LV, MC, MK, MT, NL, NO, PL, PT, RO, RS, SE,

SI, SK, SM, TR), OAPI (BF, BJ, CF, CG, CI, CM, GA,
GN, GQ, GW, KM, ML, MR, NE, SN, TD, TG).

Published:

— with international search report (Art. 21(3))

living, the chances of acquiring meaningful information and capturing an abnormal cardiac rhythm event becomes more likely to be achieved.

For instance, the long-term wear of ECG electrodes is complicated by skin irritation and the inability of conventional ECG electrodes to maintain continual skin contact after a day or
5 two. Moreover, time, dirt, moisture, and other environmental contaminants, as well as perspiration, skin oil, and dead skin cells from the patient's body, can get between an ECG electrode, the non-conductive adhesive used to adhere the ECG electrode, and the skin's surface. These factors adversely affect electrode adhesion and the quality of cardiac signal recordings. Moreover, physical movement and clothing impart compressional, tensile, and torsional forces
10 on electrode contact points decreasing signal quality, especially over long recording times. In addition, an inflexibly fastened ECG electrode is prone to dislodgement that often occurs unbeknownst to the patient, making the ECG recordings worthless. Further, some patients may have skin conditions, such as itching and irritation, aggravated by the wearing of most ECG electrodes. A patient may have to periodically remove or replace electrodes during a long-term
15 monitoring period, whether to replace a dislodged electrode, reestablish better adhesion, alleviate itching or irritation, allow for cleansing of the skin, allow for showering and exercise, or for other purpose. Such replacement or slight alteration in electrode location can interfere with the goal of recording the ECG signal for long periods of time. Finally, such recording devices are often ineffective at recording atrial electrical activity, which is critical in the accurate diagnosis
20 of heart rhythm disorders, because of the use of traditional ECG recording electronics or due to the location of the monitoring electrodes far from the origin of the atrial signal, for instance, the P-wave.

Conventionally, Holter monitors are widely used for long-term extended ECG monitoring, typically, for only 24-48 hours. A typical Holter monitor is a wearable and portable
25 version of an ECG that includes cables for each electrode placed on the skin and a separate battery-powered ECG recorder. Similar to standard in-clinic ECG practice, the cable and electrode combination (or leads) are placed in the anterior thoracic region. The duration of a Holter monitoring recording depends on the sensing and storage capabilities of the monitor, as well as battery life. A "looping" Holter (or event) monitor can operate for a longer period of
30 time by overwriting older ECG tracings, thence "recycling" storage in favor of extended operation, yet at the risk of losing crucial event data. Holter monitors remain cumbersome, expensive and typically for prescriptive use only, which limits their usability. Further, the skill required to properly place the ECG leads on the patient's chest hinders or precludes a patient from replacing or removing the electrodes.

The ZIO XT Patch and ZIO Event Card devices, manufactured by iRhythm Tech., Inc., San Francisco, CA, are wearable stick-on monitoring devices that are typically worn on the upper left pectoral region to respectively provide continuous and looping ECG recordings. The location is used to simulate surgically implanted monitors. These devices are prescription-only for single patient use. The ZIO XT Patch device is limited to 14-day monitoring, while the ZIO Event Card device's electrodes can be worn for up to 30 days. The ZIO XT Patch device combines electronic recordation components, including battery, and physical electrodes into a unitary assembly that adheres to the skin. The ZIO XT Patch device uses adhesive strong enough to support the weight of both the monitor and the electrodes over an extended period of time. During monitoring, the battery is continually depleted and can potentially limit overall monitoring duration. The ZIO Event Card device is a form of downsized Holter monitor with a recorder component that must be removed during activities that could damage the non-waterproof electronics. These patches have a further limitation because of a small inter-electrode distance coupled to its designed location of application, high on the left chest. The electrical design of the ZIO patch and its location make recording high quality atrial signals (P-waves) difficult, as the location is relatively far from the origin of these low amplitude signals. As well, the location is suboptimal for identification of these signals. Furthermore, this patch is problematical for woman by being placed in a location that may limit signal quality, especially in woman with large breasts or bosoms. Both ZIO devices represent compromises between length of wear and quality of ECG monitoring, especially with respect to ease of long term use, female-friendly fit, and quality of atrial (P-wave) signals.

Personal ambulatory monitoring, both with smartphones or via adjuncts to smartphones, such as with a wirelessly-connected monitor or activity tracker, of varying degrees of sophistication and interoperability, have become increasingly available. For instance, McManus et al., "A Novel Application for the Detection of an Irregular Pulse using an iPhone 4S in Patients with Atrial Fibrillation," Vol. 10(3), pp. 315-319 (March 2013), the disclosure of which is incorporated by reference, discloses obtaining pulsatile time series recordings before and after cardioversion using the digital camera built into a smartphone. An algorithm implemented as an app executed by the smartphone analyzed recorded signals to accurately distinguish pulse recordings during atrial fibrillation from sinus rhythm, although such a smartphone-based approach provides non-continuous observation and would be impracticable for long term physiological monitoring. Further, the smartphone-implemented app does not provide continuous recordings, including the provision of pre-event and post-event context, critical for an accurate medical diagnosis that might trigger a meaningful and serious medical intervention. In

addition, a physician would be loath to undertake a surgical or serious drug intervention without confirmatory evidence that the wearer in question was indeed the subject of the presumed rhythm abnormality. Validation of authenticity of the rhythm disorder for a specified patient takes on critical legal and medical importance.

5 The AliveCor heart monitor, manufactured by AliveCor, Inc., San Francisco, CA, provides a non-continuous, patient-triggered event monitor, which is worn on the fingertip. Heart rate is sensed over a single lead (comparable to Lead I on a conventional ECG) and recorded by an app running on a smartphone, such as an iOS operating system-based smartphone, such as the iPhone, manufactured by Apple Inc., Cupertino, CA, or an Android
10 operating system-based smartphone, manufactured and offered by various companies, including Google Inc., Mountain View, CA; Samsung Electronics Co., Ltd., Suwon, S. Korea; Motorola Mobility LLC, a subsidiary of Google Inc., Libertyville, IL; and LG Electronics Inc., Seoul, S. Korea. The Android operating system is also licensed by Google Inc. The app can send the data recorded by an AliveCor heart monitor from the smartphone to healthcare providers, who
15 ultimately decide whether to use the data for screening or diagnostic purposes. Furthermore, as explained *supra* with respect to the McManus reference, none of these devices provides the context of the arrhythmia, as well as the medico-legal confirmation that would otherwise allow for a genuine medical intervention.

 Similarly, adherents to the so-called “Quantified Self” movement combine wearable
20 sensors and wearable computing to self-track activities of their daily lives. The Fitbit Tracker, manufactured by Fitbit Inc., San Francisco, CA; the Jawbone UP, manufactured by Jawbone, San Francisco, CA; the Polar Loop, manufactured by Polar Electro, Kempele, Finland; and the Nike+ FuelBand, manufactured by Nike Inc., Beaverton, OR, for instance, provide activity trackers worn on the wrist or body with integrated fitness tracking features, such as a heart rate monitor
25 and pedometer to temporally track the number of steps taken each day with an estimation calories burned. The activity tracker can interface with a smartphone or computer to allow a wearer to monitor their progress towards a fitness goal. These activity trackers are accessories to smartphones, including iOS operating system-based smartphones, Android operating system-based smartphones, and Windows Phone operating-system based smartphones, such as
30 manufactured by Microsoft Corporation, Redmond, WA, to which recorded data must be offloaded for storage and viewing.

 The features of activity trackers can also be increasingly found in so-called “smart” watches that combine many of the features of activity trackers with smartphones. Entire product lines are beginning to be offered to provide a range of fitness- and health-tracking solutions. As

one example, Samsung Electronics Co., Ltd., offers a line of mobile products with fitness-oriented features, including the Galaxy S5 smartphone, which incorporates a biometric fingerprint reader and heart rate monitor; the Gear 2 smart watch, which also incorporates a heart rate monitor; and the Gear Fit wearable device, which incorporates a heart rate monitor, real time fitness coaching, and activity tracker. The Galaxy S5 smartphone's heart rate monitor is not meant for continuous tracking, while the both the Gear 2 smart watch and Gear Fit wearable device must be paired with a smartphone or computer to offload and view the recorded data.

With all manner of conventional "fitness-oriented" device, whether smartphone, smart watch, or activity tracker, quantified physiology is typically tracked for only the personal use of the wearer. Monitoring can be either continuous or non-continuous. The wearer must take extra steps to route recorded data to a health care provider; thus, with rare exception, the data is not time-correlated to physician-supervised monitoring nor validated. Furthermore, the monitoring is strictly informational and medically-significant events, such as serious cardiac rhythm disorders, including tachyarrhythmias and bradyarrhythmias, while potentially detectable, are neither identified nor acted upon.

In today's medical and legal environment, a mobile device, such as a smartphone, provides information that cannot be translated into data that triggers surgery or drug therapy by a physician. In the case of a smartphone detecting a fast heartbeat, for example, such a detection and the information on the smartphone would neither be identified as truly related to the patient in question or would be deemed sufficient for subjecting a patient to surgery or potentially toxic drug therapy. Thus, such data that is available today is not actionable in a medically therapeutic relevant way. To make such data actionable, one must have recorded data that allows a specific rhythm diagnosis, and a vague recording hinting that something may be wrong with the heart will not suffice. Further, the recorded data must not only identify the heart-related event of concern, but the signals before and after the event, which provides critical medical information for a physician to diagnose the disorder specifically. Finally, the recorded data must be made certifiable, so that the relationship of the recorded data to the patient that the physician is seeing is clear and appropriately identifiable as an event originating in the patient being examined. Establishing this relationship of data-to-patient has become a legally mandatory step in providing medical care, which heretofore has been impracticable insofar as one cannot merely rely upon a smartphone to provide legally sufficient identification of an abnormality with actionable data such that a patient undergoes a serious medical intervention.

Therefore, a need remains for an extended wear continuously recording ECG monitor practicably capable of being worn for a long period of time in both men and women and capable of recording high quality atrial and ventricular signals reliably.

5 A further need remains for facilities to integrate wider-ranging physiological and “life tracking”-type data into long-term ECG and physiological data monitoring coupled with an onboard ability to cascade into the medical records and to the medical authorities appropriate medical intervention upon detection of a condition of potential medical concern.

DISCLOSURE OF THE INVENTION

10 Physiological monitoring can be provided through a wearable monitor that includes two components, a flexible extended wear electrode patch and a removable reusable monitor recorder. The wearable monitor sits centrally (in the midline) on the patient’s chest along the sternum oriented top-to-bottom. The placement of the wearable monitor in a location at the sternal midline (or immediately to either side of the sternum), with its unique narrow “hourglass”-like shape, benefits long-term extended wear by removing the requirement that ECG
15 electrodes be continually placed in the same spots on the skin throughout the monitoring period. Instead, the patient is free to place an electrode patch anywhere within the general region of the sternum, the area most likely to record high quality atrial signals or P-waves. Moreover, the wearable monitor is worn in such a location that is comfortable to woman and allows wear during activity.

20 In a further embodiment, the wearable monitor can interoperate wirelessly with other wearable physiology monitors and activity sensors and with mobile devices, including so-called “smartphones,” as well as with personal computers and tablet or handheld computers, to download monitoring data either in real-time or in batches. Where a wearable physiology monitor, activity sensor, or mobile device worn or held by the patient includes the capability to
25 sense cardiac activity, particularly heart rate, or other physiology, an application executed by the monitor, sensor, or device can trigger the dispatch of a medically-actionable wearable monitor to the patient upon detecting potentially medically-significant events, such as cardiac rhythm disorders, including tachyarrhythmias and bradyarrhythmias. Upon receipt of the wearable monitor, the patient can use the sensor or device, if appropriately equipped with photographic,
30 fingerprint or thumbprint, or other recording features, to physically record the placement and use of the wearable monitor, thereby facilitating the authentication of the data recorded by the wearable monitor. Finally, the monitor recorder can also be equipped with a wireless transceiver to either provide data or other information to, or receive data or other information from, an

interfacing wearable physiology monitor, activity sensor, or mobile device for relay to an external system or further device, such as a server, analysis, or for further legal validation of the relationship of the monitor to the patient, or for other purpose.

One embodiment provides a remotely-interfaceable extended wear electrocardiography and physiological sensor monitor recorder. A sealed housing is adapted to be removably secured into the non-conductive receptacle on a disposable extended wear electrode patch. Electronic circuitry is included within the sealed housing. An externally-powered micro-controller is operable to execute under micro programmable control. An electrocardiographic front end circuit is electrically interfaced to the micro-controller and is operable to sense electrocardiographic signals through electrocardiographic electrodes provided on the disposable extended wear electrode patch, each of the electrocardiographic electrodes adapted to be positioned axially along the midline of the sternum for capturing action potential propagation. A wireless transceiver is electrically interfaced with the micro-controller and is operable to wirelessly interface with an external wireless-enabled device to communicate samples of the electrocardiographic signals. Externally-powered flash memory is electrically interfaced with the micro-controller and is operable to store the samples of the electrocardiographic signals.

A further embodiment provides a remotely-interfaceable extended wear electrocardiography and physiological sensor monitor. A disposable extended wear electrode patch includes a flexible backing formed of an elongated strip of stretchable material with a narrow longitudinal midsection and, on each end, a contact surface at least partially coated with an adhesive dressing provided as a crimp relief. A pair of electrocardiographic electrodes is conductively exposed on the contact surface of each end of the elongated strip. A non-conductive receptacle is adhered to an outward-facing end of the elongated strip and includes a plurality of electrical pads. A flexible circuit is affixed on each end of the elongated strip as a strain relief and includes a pair of circuit traces electrically coupled to the pair of electrocardiographic electrodes and a pair of the electrical pads. A reusable electrocardiography monitor has a sealed housing adapted to be removably secured into the non-conductive receptacle. A micro-controller is operable to execute under micro programmable control and is electrically interfaced to an electrocardiographic front end circuit that is operable to sense electrocardiographic signals through the electrocardiographic electrodes via the pair of electrical pads. A wireless transceiver is electrically interfaced with the micro-controller and is operable to wirelessly interface with an external wireless-enabled device to communicate samples of the electrocardiographic signals. Flash memory is electrically interfaced with the micro-controller and is operable to store the samples of the electrocardiographic signals.

A still further embodiment provides a computer-implemented system and method for providing a personal mobile device-triggered medical intervention. An activity monitor is adapted to be used proximal to a patient's body and includes a physiology sensor operable to sense physiological data of the body. A personal mobile device includes an application
5 executable by the mobile device that is configured to detect an event of potential medical significance within the sensed physiological data. The mobile device also includes a wireless transceiver operable to interface the mobile device with an external system and to send notification of a detection of the event. An extended wear electrocardiography and physiological sensor monitor recorder is dispatched by the external system upon receipt of the notification.

10 The monitoring patch is especially suited to the female anatomy. The narrow longitudinal midsection can fit nicely within the intermammary cleft of the breasts without inducing discomfort, whereas conventional patch electrodes are wide and, if adhered between the breasts, particularly hypertrophic or pendulous breasts, would cause chafing, irritation, frustration, and annoyance, leading to low patient compliance and possibly premature removal of
15 the monitoring patch. Furthermore, such conventional patches do not have the electrical design and signal processing that would allow recording of the P-wave, given the close spacing of the bipolar electrodes.

The foregoing aspects enhance ECG monitoring performance and quality, facilitating long-term ECG recording, critical to accurate arrhythmia diagnosis.

20 In addition, the foregoing aspects enhance comfort in women (and certain men), but not irritation of the breasts, by placing the monitoring patch in the best location possible for optimizing the recording of cardiac signals from the atrium, another feature critical to proper arrhythmia diagnosis.

25 Finally, the foregoing aspects as relevant to monitoring are equally applicable to recording other physiological data, such as heart rate, temperature, blood pressure, respiratory rate, blood pressure, blood sugar (with appropriate subcutaneous probe), oxygen saturation, minute ventilation, as well as other measures of body chemistry and physiology.

30 Still other embodiments will become readily apparent to those skilled in the art from the following detailed description, wherein are described embodiments by way of illustrating the best mode contemplated. As will be realized, other and different embodiments are possible and the embodiments' several details are capable of modifications in various obvious respects, all without departing from their spirit and the scope. Accordingly, the drawings and detailed description are to be regarded as illustrative in nature and not as restrictive.

DESCRIPTION OF THE DRAWINGS

FIGURES 1 and 2 are diagrams showing, by way of examples, an extended wear electrocardiography and physiological sensor monitor respectively fitted to the sternal region of a female patient and a male patient.

5 FIGURE 3 is a functional block diagram showing a system for remote interfacing of an extended wear electrocardiography and physiological sensor monitor in accordance with one embodiment.

FIGURE 4 is a perspective view showing an extended wear electrode patch with a monitor recorder inserted.

10 FIGURE 5 is a perspective view showing the monitor recorder of FIGURE 4.

FIGURE 6 is a perspective view showing the extended wear electrode patch of FIGURE 4 without a monitor recorder inserted.

FIGURE 7 is a bottom plan view of the monitor recorder of FIGURE 4.

15 FIGURE 8 is a top view showing the flexible circuit of the extended wear electrode patch of FIGURE 4 when mounted above the flexible backing.

FIGURE 9 is a functional block diagram showing the component architecture of the circuitry of the monitor recorder of FIGURE 4.

FIGURE 10 is a functional block diagram showing the circuitry of the extended wear electrode patch of FIGURE 4.

20 FIGURE 11 is a flow diagram showing a monitor recorder-implemented method for monitoring ECG data for use in the monitor recorder of FIGURE 4.

FIGURE 12 is a graph showing, by way of example, a typical ECG waveform.

25 FIGURE 13 is a flow diagram showing a method for offloading and converting ECG and other physiological data from an extended wear electrocardiography and physiological sensor monitor in accordance with one embodiment.

BEST MODE FOR CARRYING OUT THE INVENTION

Physiological monitoring can be provided through a wearable monitor that includes two components, a flexible extended wear electrode patch and a removable reusable monitor recorder. FIGURES 1 and 2 are diagrams showing, by way of examples, an extended wear electrocardiography and physiological sensor monitor 12, including a monitor recorder 14 in accordance with one embodiment, respectively fitted to the sternal region of a female patient 10 and a male patient 11. The wearable monitor 12 sits centrally (in the midline) on the patient's chest along the sternum 13 oriented top-to-bottom with the monitor recorder 14 preferably

situated towards the patient's head. In a further embodiment, the orientation of the wearable monitor 12 can be corrected post-monitoring, as further described *infra*. The electrode patch 15 is shaped to fit comfortably and conformal to the contours of the patient's chest approximately centered on the sternal midline 16 (or immediately to either side of the sternum 13). The distal end of the electrode patch 15 extends towards the Xiphoid process and, depending upon the patient's build, may straddle the region over the Xiphoid process. The proximal end of the electrode patch 15, located under the monitor recorder 14, is below the manubrium and, depending upon patient's build, may straddle the region over the manubrium.

The placement of the wearable monitor 12 in a location at the sternal midline 16 (or immediately to either side of the sternum 13) significantly improves the ability of the wearable monitor 12 to cutaneously sense cardiac electric signals, particularly the P-wave (or atrial activity) and, to a lesser extent, the QRS interval signals in the ECG waveforms that indicate ventricular activity, while simultaneously facilitating comfortable long-term wear for many weeks. The sternum 13 overlies the right atrium of the heart and the placement of the wearable monitor 12 in the region of the sternal midline 13 puts the ECG electrodes of the electrode patch 15 in a location better adapted to sensing and recording P-wave signals than other placement locations, say, the upper left pectoral region or lateral thoracic region or the limb leads. In addition, placing the lower or inferior pole (ECG electrode) of the electrode patch 15 over (or near) the Xiphoid process facilitates sensing of ventricular activity and provides superior recordation of the QRS interval.

When operated standalone, the monitor recorder 14 of the extended wear electrocardiography and physiological sensor monitor 12 senses and records the patient's ECG data into an onboard memory. In addition, the wearable monitor 12 can interoperate with other devices. FIGURE 3 is a functional block diagram showing a system 120 for remote interfacing of an extended wear electrocardiography and physiological sensor monitor 12 in accordance with one embodiment. The monitor recorder 14 is a reusable component that can be fitted during patient monitoring into a non-conductive receptacle provided on the electrode patch 15, as further described *infra* with reference to FIGURE 4, and later removed for offloading of stored ECG data or to receive revised programming. The monitor recorder 14 can then be connected to a download station 125, which could be a programmer or other device that permits the retrieval of stored ECG monitoring data, execution of diagnostics on or programming of the monitor recorder 14, or performance of other functions. The monitor recorder 14 has a set of electrical contacts (not shown) that enable the monitor recorder 14 to physically interface to a set of terminals 128 on a paired receptacle 127 of the download station 125. In turn, the download

station 125 executes a communications or offload program 126 (“Offload”) or similar program that interacts with the monitor recorder 14 via the physical interface to retrieve the stored ECG monitoring data. The download station 125 could be a server, personal computer, tablet or handheld computer, smart mobile device, or purpose-built programmer designed specific to the task of interfacing with a monitor recorder 14. Still other forms of download station 125 are possible.

Upon retrieving stored ECG monitoring data from a monitor recorder 14, middleware first operates on the retrieved data to adjust the ECG capture quality, as necessary, and to convert the retrieved data into a format suitable for use by third party post-monitoring analysis software, as further described *infra* with reference to FIGURE 13. The formatted data can then be retrieved from the download station 125 over a hard link 135 using a control program 137 (“Ctl”) or analogous application executing on a personal computer 136 or other connectable computing device, via a communications link (not shown), whether wired or wireless, or by physical transfer of storage media (not shown). The personal computer 136 or other connectable device may also execute middleware that converts ECG data and other information into a format suitable for use by a third-party post-monitoring analysis program, as further described *infra* with reference to FIGURE 13. Note that formatted data stored on the personal computer 136 would have to be maintained and safeguarded in the same manner as electronic medical records (EMRs) 134 in the secure database 124, as further discussed *infra*. In a further embodiment, the download station 125 is able to directly interface with other devices over a computer communications network 121, which could be some combination of a local area network and a wide area network, including the Internet, over a wired or wireless connection.

A client-server model could be used to employ a server 122 to remotely interface with the download station 125 over the network 121 and retrieve the formatted data or other information. The server 122 executes a patient management program 123 (“Mgt”) or similar application that stores the retrieved formatted data and other information in a secure database 124 cataloged in that patient’s EMRs 134. In addition, the patient management program 123 could manage a subscription service that authorizes a monitor recorder 14 to operate for a set period of time or under pre-defined operational parameters.

The patient management program 123, or other trusted application, also maintains and safeguards the secure database 124 to limit access to patient EMRs 134 to only authorized parties for appropriate medical or other uses, such as mandated by state or federal law, such as under the Health Insurance Portability and Accountability Act (HIPAA) or per the European Union’s Data Protection Directive. For example, a physician may seek to review and evaluate his patient’s

ECG monitoring data, as securely stored in the secure database 124. The physician would execute an application program 130 (“Pgm”), such as a post-monitoring ECG analysis program, on a personal computer 129 or other connectable computing device, and, through the application 130, coordinate access to his patient’s EMRs 134 with the patient management program 123.

5 Other schemes and safeguards to protect and maintain the integrity of patient EMRs 134 are possible.

The wearable monitor 12 can interoperate wirelessly with other wearable physiology monitors and activity sensors 131, such as activity trackers worn on the wrist or body, and with mobile devices 133, including smart watches and smartphones. Wearable physiology monitors and activity sensors 131 encompass a wide range of wirelessly interconnectable devices that measure or monitor a patient’s physiological data, such as heart rate, temperature, blood pressure, respiratory rate, blood pressure, blood sugar (with appropriate subcutaneous probe), oxygen saturation, minute ventilation, and so on; physical states, such as movement, sleep, footsteps, and the like; and performance, including calories burned or estimated blood glucose level. The physiology sensors in non-wearable mobile devices, particularly smartphones, are generally not meant for continuous tracking and do not provide medically precise and actionable data sufficient for a physician to prescribe a surgical or serious drug intervention; such data can be considered screening information that something may be wrong, but not data that provides the highly precise information that may allow for a surgery, such as implantation of a pacemaker for heart block or a defibrillator for ventricular tachycardia, or the application of serious medications, like blood thinners for atrial fibrillation or a cardiac ablation procedure. Such devices, like smartphones, are better suited to pre- and post-exercise monitoring or as devices that can provide a signal that something is wrong, but not in the sufficient detail and validation to allow for medical action. Conversely, medically actionable wearable sensors and devices sometimes provide continuous recording for relatively short time periods, but must be paired with a smartphone or computer to offload and evaluate the recorded data, especially if the data is of urgent concern.

Wearable physiology monitors and activity sensors 131, also known as “activity monitors,” and to a lesser extent, “fitness” sensor-equipped mobile devices 133, can trace their life-tracking origins to ambulatory devices used within the medical community to sense and record traditional medical physiology that could be useful to a physician in arriving at a patient diagnosis or clinical trajectory, as well as from outside the medical community, from, for instance, sports or lifestyle product companies who seek to educate and assist individuals with self-quantifying interests. Data is typically tracked by the wearable physiology monitors or

activity sensors 131 and mobile device 133 for only the personal use of the wearer. The physiological monitoring is strictly informational, even where a device originated within the medical community, and the data is generally not time-correlated to physician-supervised monitoring. Importantly, medically-significant events, such as cardiac rhythm disorders, including tachyarrhythmias, like ventricular tachycardia or atrial fibrillation, and bradyarrhythmias, like heart block, while potentially detectable with the appropriate diagnostic heuristics, are neither identified nor acted upon by the wearable physiology monitors and activity sensors 131 and the mobile device 133.

Frequently, wearable physiology monitors and activity sensors 131 are capable of wirelessly interfacing with mobile devices 133, particularly smart mobile devices, including so-called “smartphones” and “smart watches,” as well as with personal computers and tablet or handheld computers, to download monitoring data either in real-time or in batches. The wireless interfacing of such activity monitors is generally achieved using transceivers that provide low-power, short-range wireless communications, such as Bluetooth, although some wearable physiology monitors and activity sensors 131, like their mobile device cohorts, have transceivers that provide true wireless communications services, including 4G or better mobile telecommunications, over a telecommunications network. Other types of wireless and wired interfacing are possible.

Where the wearable physiology monitors and activity sensors 131 are paired with a mobile device 133, the mobile device 133 executes an application (“App”) that can retrieve the data collected by the wearable physiology monitor and activity sensor 131 and evaluate the data to generate information of interest to the wearer, such as an estimation of the effectiveness of the wearer’s exercise efforts. Where the wearable physiology monitors and activity sensors 131 has sufficient onboard computational resources, the activity monitor itself executes an app without the need to relay data to a mobile device 133. Generally, such more computationally-capable wearable physiology monitors and activity sensors are also equipped with wireless communications services transceivers, such as found in some smart watches that combine the features of activity monitors with mobile devices. Still other activity monitor and mobile device functions on the collected data are possible.

In a further embodiment, a wearable physiology monitor, activity sensor 131, or mobile device 133 worn or held by the patient 10, or otherwise be used proximal to the patient’s body, can be used to first obtain and then work collaboratively with a more definitive monitor recorder 14 to enable the collection of physiology by the monitor recorder 14 before, during, and after potentially medically-significant events. The wearable physiology monitor, activity sensor 131,

or mobile device 133 must be capable of sensing cardiac activity, particularly heart rate or rhythm, or other types of physiology or measures, either directly or upon review of relayed data. Where the wearable physiology monitor or activity sensor 131 is paired with a mobile device 133, the mobile device 133 serves as a relay device and executes an application that will trigger the dispatch of a monitor recorder 14 to the patient 10 upon detecting potentially medically-significant events in the data provided by the paired activity monitor, such as cardiac rhythm disorders, including tachyarrhythmias and bradyarrhythmias. If the mobile device 133 is itself performing the monitoring of the patient's physiology, the mobile device 133 executes an application that will trigger the dispatch of a monitor recorder 14 to the patient 10 in near-real time upon detecting potentially medically-significant events, thereby avoiding the delay incurred by data relay from an activity monitor. Finally, if the wearable physiology monitor or activity sensor 131 has sufficient onboard computational resources and also is equipped with a wireless communications services transceiver, the wearable physiology monitor or activity sensor 131 effectively becomes the mobile device 133 and executes an application that will trigger the dispatch of a monitor recorder 14 to the patient 10 in near-real time upon detecting potentially medically-significant events without the need to first interface with a mobile device 133. Still other configurations of the detection app are possible.

The act of triggering the dispatch of a monitor recorder 14 represents the first step in a cascade of possible medical interventions of potentially increasing seriousness and urgency. Sensors 131 and devices 133 are generally not capable of detecting and recording medically precise and actionable data, whereas, as a device designed for extended wear, the monitor recorder 14 continually monitors the patient's physiology over a long time period and will capture any medically-actionable data leading up to, throughout the occurrence of, and following an event of potential medical concern.

The monitoring data recorded by the monitor recorder 14 can be uploaded directly into the patient's EMRs 134, either by using a mobile device 133 as a conduit for communications with a server 122 coupled to a secure database 124 within which the patient's EMRs 134 are stored, or directly to the server 122, if the monitor recorder 14 is appropriately equipped with a wireless transceiver or similar external data communications interface, as further described *infra*. Thus, the data recorded by the monitor recorder 14 would directly feed into the patient's EMRs 134, thereby allowing the data to be made certifiable for immediate use by a physician or healthcare provider. No intermediate steps would be necessary when going from cutaneously sensing cardiac electric signals and collecting the patient's physiology using a monitor recorder 14 to presenting that recorded data to a physician or healthcare provider for medical diagnosis

and care. The direct feeding of data from the monitor recorder 14 to the EMRs 134 clearly establishes the relationship of the data, as recorded by the monitor recorder 14, to the patient 10 that the physician is seeing and appropriately identifies any potentially medically-significant event recorded in the data as originating in the patient 10 and nobody else. Based on the
5 monitoring data, physicians and healthcare providers can rely on the data as certifiable and can directly proceed with determining the appropriate course of treatment for the patient 10, including undertaking further medical interventions as appropriate. In a further embodiment, the server 122 can evaluate the recorded data, as fed into the patient's EMRs 134, to refer the patient
10 10 for medical care to a general practice physician or medical specialist, for instance, a cardiac electrophysiologist referral from a cardiologist when the recorded data indicates an event of sufficient potential severity to warrant the possible implantation of a pacemaker for heart block or a defibrillator for ventricular tachycardia. Other uses of the data recorded by the monitor recorder 14 are possible.

For instance, a patient 10 who has previously suffered heart failure is particularly
15 susceptible to ventricular tachycardia following a period of exercise or strenuous physical activity. A wearable sensor 131 or device 133 that includes a heart rate monitor would be able to timely detect an irregularity in heart rhythm. The application executed by the sensor 131 or device 133 allows those devices to take action by triggering the dispatch of a monitor recorder 14 to the patient 10, even though the data recorded by the sensor 131 or device 133 is itself
20 generally medically-insufficient for purposes of diagnosis and care. Thus, rather than passively recording patient data, the sensor 131 or device 133 takes on an active role in initiating the provisioning of medical care to the patient 10 and starts a cascade of appropriate medical interventions under the tutelage of and followed by physicians and trained healthcare professionals.

25 In a still further embodiment, the monitor recorder 14 could upload an event detection application to the sensor 131 or device 133 to enable those devices to detect those types of potentially medically-significant events, which would trigger the dispatch of a monitor recorder 14 to the patient 10. Alternatively, the event detection application could be downloaded to the sensor 131 or device 133 from an online application store or similar online application
30 repository. Finally, the monitor recorder 14 could use the sensor 131 or device 133 to generate an appropriate alert, including contacting the patient's physician or healthcare services, via wireless (or wired) communications, upon detecting a potentially medically-significant event or in response to a patient prompting.

The patient 10 could be notified by the sensor 131 or device 133, through the sensor's or device's user interface, that an event of potential medical concern has been detected coupled with an offer to have a monitor recorder 14 sent out to the patient 10, assuming that the patient 10 is not already wearing a monitor recorder 14. Alternatively, the sensor 131 or device 133 could unilaterally send out a request for a monitor recorder 14. The request for a monitor recorder 14 could be sent via wireless (or wired) communications to the patient's physician, a medical service provider organization, a pharmacy, an emergency medical service, or other appropriate healthcare entity that would, in turn, physically provide the patient with a monitor recorder 14. The patient 10 could also be told to pick up a monitor recorder 14 directly from one of the above-identified sources.

Conventional Holter monitors, as well as the ZIO XT Patch and ZIO Event Card devices, described *supra*, are currently available only by a physician's prescription for a specific patient 10. As a result, the physiological data recorded by these monitors and devices are assumed by healthcare professional to belong to the patient 10. In this prescriptive medicine context, grave questions as to the authenticity of the patient's identity and the data recorded do not generally arise, although current medical practice still favors requesting affirmative patient and caregiver identification at every step of healthcare provisioning. As a device intended for adoption and usage broader than prescriptive medicine, the monitor recorder 14 carries the potential to be used by more than one individual, which can raise concerns as to the veracity of the data recorded.

In a still further embodiment, the mobile device 133, or, if properly equipped, the activity monitor, can be used to help authenticate the patient 10 at the outset of and throughout the monitoring period. The mobile device 133 (or activity monitor) must be appropriately equipped with a digital camera or other feature capable of recording physical indicia located within the proximity of the mobile device 133. For instance, the Samsung Galaxy S5 smartphone has both a biometric fingerprint reader and autofocus digital camera built in. Upon receipt of a monitor recorder 14, the patient 10 can use the photographic or other recording features of the mobile device 133 (or activity monitor) to physically record the placement and use of the monitor recorder 14. For instance, the patient 10 could take a picture or make a video of the monitor recorder 14 using as applied to the chest using the built-in digital camera. The patient 10 could also swipe a finger over the biometric fingerprint reader. Preferably, the patient 10 would include both his or her face or similar uniquely-identifying marks or indicia, such as a scar, tattoo, body piercing, or RFID chip, plus any visible or electronic indicia on the outside of the monitor recorder's housing, as further described *infra* with reference to FIGURE 5, in the physical recording. The physical recording would then be sent by the mobile device 133 (or

activity monitor) via wireless (or wired) communications to the patient's physician's office or other appropriate caregiver, thereby facilitating the authentication of the data recorded by the monitor recorder 14. Alternatively, the physical recording could be securely stored by the monitor recorder 14 as part of the monitoring data set.

5 The mobile device 133 could also serve as a conduit for providing the data collected by the wearable physiology monitor or activity sensor 131 to a server 122, or, similarly, the wearable physiology monitor or activity sensor 131 could itself directly provide the collected data to the server 122. The server 122 could then merge the collected data into the wearer's EMRs 134 in the secure database 124, if appropriate (and permissible), or the server 122 could perform an analysis of the collected data, perhaps based by comparison to a population of like wearers of the wearable physiology monitor or activity sensor 131. Still other server 122 functions on the collected data are possible.

 Finally, the monitor recorder 14 can also be equipped with a wireless transceiver, as further described *infra* with reference to FIGURES 9 and 10. Thus, when wireless-enabled, both 15 wearable physiology monitors, activity sensors 131, and mobile devices 133 can wirelessly interface with the monitor recorder 14, which could either provide data or other information to, or receive data or other information from an interfacing device for relay to a further device, such as the server 122, analysis, or other purpose. In addition, the monitor recorder 14 could wirelessly interface directly with the server 122, personal computer 129, or other computing 20 device connectable over the network 121, when the monitor recorder 14 is appropriately equipped for interfacing with such devices. Still other types of remote interfacing of the monitor recorder 14 are possible.

 During use, the electrode patch 15 is first adhered to the skin along the sternal midline 16 (or immediately to either side of the sternum 13). A monitor recorder 14 is then snapped into 25 place on the electrode patch 15 to initiate ECG monitoring. FIGURE 4 is a perspective view showing an extended wear electrode patch 15 with a monitor recorder 14 in accordance with one embodiment inserted. The body of the electrode patch 15 is preferably constructed using a flexible backing 20 formed as an elongated strip 21 of wrap knit or similar stretchable material with a narrow longitudinal mid-section 23 evenly tapering inward from both sides. A pair of cut- 30 outs 22 between the distal and proximal ends of the electrode patch 15 create a narrow longitudinal midsection 23 or "isthmus" and defines an elongated "hourglass"-like shape, when viewed from above.

 The electrode patch 15 incorporates features that significantly improve wearability, performance, and patient comfort throughout an extended monitoring period. During wear, the

electrode patch 15 is susceptible to pushing, pulling, and torquing movements, including compressional and torsional forces when the patient bends forward, and tensile and torsional forces when the patient leans backwards. To counter these stress forces, the electrode patch 15 incorporates strain and crimp reliefs, such as described in commonly-assigned U.S. Patent application, entitled "Extended Wear Electrocardiography Patch," Serial No. 14/080,717, filed 5 November 14, 2013, pending, the disclosure of which is incorporated by reference. In addition, the cut-outs 22 and longitudinal midsection 23 help minimize interference with and discomfort to breast tissue, particularly in women (and gynecomastic men). The cut-outs 22 and longitudinal midsection 23 further allow better conformity of the electrode patch 15 to sternal bowing and to 10 the narrow isthmus of flat skin that can occur along the bottom of the intermammary cleft between the breasts, especially in buxom women. The cut-outs 22 and longitudinal midsection 23 help the electrode patch 15 fit nicely between a pair of female breasts in the intermammary cleft. Still other shapes, cut-outs and conformities to the electrode patch 15 are possible.

The monitor recorder 14 removably and reusably snaps into an electrically non- 15 conductive receptacle 25 during use. The monitor recorder 14 contains electronic circuitry for recording and storing the patient's electrocardiography as sensed via a pair of ECG electrodes provided on the electrode patch 15, such as described in commonly-assigned U.S. Patent Application, entitled "Extended Wear Ambulatory Electrocardiography and Physiological Sensor Monitor," Serial No. 14/080,725, filed November 14, 2013, pending, the disclosure which is 20 incorporated by reference. The non-conductive receptacle 25 is provided on the top surface of the flexible backing 20 with a retention catch 26 and tension clip 27 molded into the non-conductive receptacle 25 to conformably receive and securely hold the monitor recorder 14 in place.

The monitor recorder 14 includes a sealed housing that snaps into place in the non- 25 conductive receptacle 25. FIGURE 5 is a perspective view showing the monitor recorder 14 of FIGURE 4. The sealed housing 50 of the monitor recorder 14 intentionally has a rounded isosceles trapezoidal-like shape 52, when viewed from above, such as described in commonly-assigned U.S. Design Patent application, entitled "Electrocardiography Monitor," Serial No. 29/472,046, filed November 7, 2013, pending, the disclosure of which is incorporated by 30 reference. In addition, a label, barcode, QR code, or other visible or electronic indicia is printed on the outside of, applied to the outside of, or integrated into the sealed housing 50 to uniquely identify the monitor recorder 14 and can include a serial number, manufacturing lot number, date of manufacture, and so forth. The edges 51 along the top and bottom surfaces are rounded for patient comfort. The sealed housing 50 is approximately 47 mm long, 23 mm wide at the widest

point, and 7 mm high, excluding a patient-operable tactile-feedback button 55. The sealed housing 50 can be molded out of polycarbonate, ABS, or an alloy of those two materials. The button 55 is waterproof and the button's top outer surface is molded silicon rubber or similar soft pliable material. A retention detent 53 and tension detent 54 are molded along the edges of the top surface of the housing 50 to respectively engage the retention catch 26 and the tension clip 27 molded into non-conductive receptacle 25. Other shapes, features, and conformities of the sealed housing 50 are possible.

The electrode patch 15 is intended to be disposable. The monitor recorder 14, however, is reusable and can be transferred to successive electrode patches 15 to ensure continuity of monitoring. The placement of the wearable monitor 12 in a location at the sternal midline 16 (or immediately to either side of the sternum 13) benefits long-term extended wear by removing the requirement that ECG electrodes be continually placed in the same spots on the skin throughout the monitoring period. Instead, the patient is free to place an electrode patch 15 anywhere within the general region of the sternum 13.

As a result, at any point during ECG monitoring, the patient's skin is able to recover from the wearing of an electrode patch 15, which increases patient comfort and satisfaction, while the monitor recorder 14 ensures ECG monitoring continuity with minimal effort. A monitor recorder 14 is merely unsnapped from a worn out electrode patch 15, the worn out electrode patch 15 is removed from the skin, a new electrode patch 15 is adhered to the skin, possibly in a new spot immediately adjacent to the earlier location, and the same monitor recorder 14 is snapped into the new electrode patch 15 to reinitiate and continue the ECG monitoring.

During use, the electrode patch 15 is first adhered to the skin in the sternal region. FIGURE 6 is a perspective view showing the extended wear electrode patch 15 of FIGURE 4 without a monitor recorder 14 inserted. A flexible circuit 32 is adhered to each end of the flexible backing 20. A distal circuit trace 33 and a proximal circuit trace (not shown) electrically couple ECG electrodes (not shown) to a pair of electrical pads 34. The electrical pads 34 are provided within a moisture-resistant seal 35 formed on the bottom surface of the non-conductive receptacle 25. When the monitor recorder 14 is securely received into the non-conductive receptacle 25, that is, snapped into place, the electrical pads 34 interface to electrical contacts (not shown) protruding from the bottom surface of the monitor recorder 14, and the moisture-resistant seal 35 enables the monitor recorder 14 to be worn at all times, even during bathing or other activities that could expose the monitor recorder 14 to moisture.

In addition, a battery compartment 36 is formed on the bottom surface of the non-conductive receptacle 25, and a pair of battery leads (not shown) electrically interface the battery

to another pair of the electrical pads 34. The battery contained within the battery compartment 35 can be replaceable, rechargeable or disposable.

The monitor recorder 14 draws power externally from the battery provided in the non-conductive receptacle 25, thereby uniquely obviating the need for the monitor recorder 14 to carry a dedicated power source. FIGURE 7 is a bottom plan view of the monitor recorder 14 of FIGURE 4. A cavity 58 is formed on the bottom surface of the sealed housing 50 to accommodate the upward projection of the battery compartment 36 from the bottom surface of the non-conductive receptacle 25, when the monitor recorder 14 is secured in place on the non-conductive receptacle 25. A set of electrical contacts 56 protrude from the bottom surface of the sealed housing 50 and are arranged in alignment with the electrical pads 34 provided on the bottom surface of the non-conductive receptacle 25 to establish electrical connections between the electrode patch 15 and the monitor recorder 14. In addition, a seal coupling 57 circumferentially surrounds the set of electrical contacts 56 and securely mates with the moisture-resistant seal 35 formed on the bottom surface of the non-conductive receptacle 25.

The placement of the flexible backing 20 on the sternal midline 16 (or immediately to either side of the sternum 13) also helps to minimize the side-to-side movement of the wearable monitor 12 in the left- and right-handed directions during wear. To counter the dislodgment of the flexible backing 20 due to compressional and torsional forces, a layer of non-irritating adhesive, such as hydrocolloid, is provided at least partially on the underside, or contact, surface of the flexible backing 20, but only on the distal end 30 and the proximal end 31. As a result, the underside, or contact surface of the longitudinal midsection 23 does not have an adhesive layer and remains free to move relative to the skin. Thus, the longitudinal midsection 23 forms a crimp relief that respectively facilitates compression and twisting of the flexible backing 20 in response to compressional and torsional forces. Other forms of flexible backing crimp reliefs are possible.

Unlike the flexible backing 20, the flexible circuit 32 is only able to bend and cannot stretch in a planar direction. The flexible circuit 32 can be provided either above or below the flexible backing 20. FIGURE 8 is a top view showing the flexible circuit 32 of the extended wear electrode patch 15 of FIGURE 4 when mounted above the flexible backing 20. A distal ECG electrode 38 and proximal ECG electrode 39 are respectively coupled to the distal and proximal ends of the flexible circuit 32. A strain relief 40 is defined in the flexible circuit 32 at a location that is partially underneath the battery compartment 36 when the flexible circuit 32 is affixed to the flexible backing 20. The strain relief 40 is laterally extendable to counter dislodgment of the ECG electrodes 38, 39 due to tensile and torsional forces. A pair of strain

relief cutouts 41 partially extend transversely from each opposite side of the flexible circuit 32 and continue longitudinally towards each other to define in 'S'-shaped pattern, when viewed from above. The strain relief respectively facilitates longitudinal extension and twisting of the flexible circuit 32 in response to tensile and torsional forces. Other forms of circuit board strain relief are possible.

ECG monitoring and other functions performed by the monitor recorder 14 are provided through a micro controlled architecture. FIGURE 9 is a functional block diagram showing the component architecture of the circuitry 60 of the monitor recorder 14 of FIGURE 4. The circuitry 60 is externally powered through a battery provided in the non-conductive receptacle 25 (shown in FIGURE 6). Both power and raw ECG signals, which originate in the pair of ECG electrodes 38, 39 (shown in FIGURE 8) on the distal and proximal ends of the electrode patch 15, are received through an external connector 65 that mates with a corresponding physical connector on the electrode patch 15. The external connector 65 includes the set of electrical contacts 56 that protrude from the bottom surface of the sealed housing 50 and which physically and electrically interface with the set of pads 34 provided on the bottom surface of the non-conductive receptacle 25. The external connector includes electrical contacts 56 for data download, microcontroller communications, power, analog inputs, and a peripheral expansion port. The arrangement of the pins on the electrical connector 65 of the monitor recorder 14 and the device into which the monitor recorder 14 is attached, whether an electrode patch 15 or download station (not shown), follow the same electrical pin assignment convention to facilitate interoperability. The external connector 65 also serves as a physical interface to a download station that permits the retrieval of stored ECG monitoring data, communication with the monitor recorder 14, and performance of other functions.

Operation of the circuitry 60 of the monitor recorder 14 is managed by a microcontroller 61. The micro-controller 61 includes a program memory unit containing internal flash memory that is readable and writeable. The internal flash memory can also be programmed externally. The micro-controller 61 draws power externally from the battery provided on the electrode patch 15 via a pair of the electrical contacts 56. The microcontroller 61 connects to the ECG front end circuit 63 that measures raw cutaneous electrical signals and generates an analog ECG signal representative of the electrical activity of the patient's heart over time.

The circuitry 60 of the monitor recorder 14 also includes a flash memory 62, which the micro-controller 61 uses for storing ECG monitoring data and other physiology and information. The flash memory 62 also draws power externally from the battery provided on the electrode patch 15 via a pair of the electrical contacts 56. Data is stored in a serial flash memory circuit,

which supports read, erase and program operations over a communications bus. The flash memory 62 enables the microcontroller 61 to store digitized ECG data. The communications bus further enables the flash memory 62 to be directly accessed externally over the external connector 65 when the monitor recorder 14 is interfaced to a download station.

5 The circuitry 60 of the monitor recorder 14 further includes an actigraphy sensor 64 implemented as a 3-axis accelerometer. The accelerometer may be configured to generate interrupt signals to the microcontroller 61 by independent initial wake up and free fall events, as well as by device position. In addition, the actigraphy provided by the accelerometer can be used during post-monitoring analysis to correct the orientation of the monitor recorder 14 if, for
10 instance, the monitor recorder 14 has been inadvertently installed upside down, that is, with the monitor recorder 14 oriented on the electrode patch 15 towards the patient's feet, as well as for other event occurrence analyses, such as described in commonly-assigned U.S. Patent application, entitled "Event Alerting Through Actigraphy Embedded within Electrocardiographic Data," Serial No. 14/082,108, filed November 16, 2013, pending, the disclosure of which is
15 incorporated by reference.

 The circuitry 60 of the monitor recorder 14 includes a wireless transceiver 69 that can provides wireless interfacing capabilities. The wireless transceiver 69 also draws power externally from the battery provided on the electrode patch 15 via a pair of the electrical contacts
20 56. The wireless transceiver 69 can be implemented using one or more forms of wireless communications, including the IEEE 802.11 computer communications standard, that is Wi-Fi; the 4G mobile phone mobile standard; the Bluetooth data exchange standard; or other wireless communications or data exchange standards and protocols. The type of wireless interfacing capability could limit the range of interoperability of the monitor recorder 14; for instance, Bluetooth-based implementations are designed for low power consumption with a short
25 communications range.

 The microcontroller 61 includes an expansion port that also utilizes the communications bus. External devices, separately drawing power externally from the battery provided on the electrode patch 15 or other source, can interface to the microcontroller 61 over the expansion port in half duplex mode. For instance, an external physiology sensor can be provided as part of
30 the circuitry 60 of the monitor recorder 14, or can be provided on the electrode patch 15 with communication with the micro-controller 61 provided over one of the electrical contacts 56. The physiology sensor can include an SpO₂ sensor, blood pressure sensor, temperature sensor, respiratory rate sensor, glucose sensor, airflow sensor, volumetric pressure sensing, or other types of sensor or telemetric input sources. For instance, the integration of an airflow sensor is

described in commonly-assigned U.S. Patent Application, entitled “Self-Contained Personal Air Flow Sensing Monitor,” Serial No. 14/082,102, filed November 15, 2013, pending, the disclosure which is incorporated by reference.

Finally, the circuitry 60 of the monitor recorder 14 includes patient-interfaceable components, including a tactile feedback button 66, which a patient can press to mark events or to perform other functions, and a buzzer 67, such as a speaker, magnetic resonator or piezoelectric buzzer. The buzzer 67 can be used by the microcontroller 61 to output feedback to a patient such as to confirm power up and initiation of ECG monitoring. Still other components as part of the circuitry 60 of the monitor recorder 14 are possible.

While the monitor recorder 14 operates under micro control, most of the electrical components of the electrode patch 15 operate passively. FIGURE 10 is a functional block diagram showing the circuitry 70 of the extended wear electrode patch 15 of FIGURE 4. The circuitry 70 of the electrode patch 15 is electrically coupled with the circuitry 60 of the monitor recorder 14 through an external connector 74. The external connector 74 is terminated through the set of pads 34 provided on the bottom of the non-conductive receptacle 25, which electrically mate to corresponding electrical contacts 56 protruding from the bottom surface of the sealed housing 50 to electrically interface the monitor recorder 14 to the electrode patch 15.

The circuitry 70 of the electrode patch 15 performs three primary functions. First, a battery 71 is provided in a battery compartment formed on the bottom surface of the non-conductive receptacle 25. The battery 71 is electrically interfaced to the circuitry 60 of the monitor recorder 14 as a source of external power. The unique provisioning of the battery 71 on the electrode patch 15 provides several advantages. First, the locating of the battery 71 physically on the electrode patch 15 lowers the center of gravity of the overall wearable monitor 12 and thereby helps to minimize shear forces and the effects of movements of the patient and clothing. Moreover, the housing 50 of the monitor recorder 14 is sealed against moisture and providing power externally avoids having to either periodically open the housing 50 for the battery replacement, which also creates the potential for moisture intrusion and human error, or to recharge the battery, which can potentially take the monitor recorder 14 off line for hours at a time. In addition, the electrode patch 15 is intended to be disposable, while the monitor recorder 14 is a reusable component. Each time that the electrode patch 15 is replaced, a fresh battery is provided for the use of the monitor recorder 14, which enhances ECG monitoring performance quality and duration of use. Finally, the architecture of the monitor recorder 14 is open, in that other physiology sensors or components can be added by virtue of the expansion port of the microcontroller 61. Requiring those additional sensors or components to draw power from a

source external to the monitor recorder 14 keeps power considerations independent of the monitor recorder 14. Thus, a battery of higher capacity could be introduced when needed to support the additional sensors or components without effecting the monitor recorders circuitry 60.

5 Second, the pair of ECG electrodes 38, 39 respectively provided on the distal and proximal ends of the flexible circuit 32 are electrically coupled to the set of pads 34 provided on the bottom of the non-conductive receptacle 25 by way of their respective circuit traces 33, 37. The signal ECG electrode 39 includes a protection circuit 72, which is an inline resistor that protects the patient from excessive leakage current.

10 Last, in a further embodiment, the circuitry 70 of the electrode patch 15 includes a cryptographic circuit 73 to authenticate an electrode patch 15 for use with a monitor recorder 14. The cryptographic circuit 73 includes a device capable of secure authentication and validation. The cryptographic device 73 ensures that only genuine, non-expired, safe, and authenticated electrode patches 15 are permitted to provide monitoring data to a monitor recorder 14, such as
15 described in commonly-assigned U.S. Patent Application, entitled "Self-Authenticating Electrocardiography Circuit," Serial No. 14/082,066, filed November 15, 2013, pending, the disclosure which is incorporated by reference.

In a further embodiment, the circuitry 70 of the electrode patch 15 includes a wireless transceiver 75, in lieu the including of the wireless transceiver 69 in the circuitry 60 of the
20 monitor recorder 14, which interfaces with the microcontroller 61 over the microcontroller's expansion port via the external connector 74.

The monitor recorder 14 continuously monitors the patient's heart rate and physiology. FIGURE 11 is a flow diagram showing a monitor recorder-implemented method 100 for monitoring ECG data for use in the monitor recorder 14 of FIGURE 4. Initially, upon being
25 connected to the set of pads 34 provided with the non-conductive receptacle 25 when the monitor recorder 14 is snapped into place, the microcontroller 61 executes a power up sequence (step 101). During the power up sequence, the voltage of the battery 71 is checked, the state of the flash memory 62 is confirmed, both in terms of operability check and available capacity, and microcontroller operation is diagnostically confirmed. In a further embodiment, an
30 authentication procedure between the microcontroller 61 and the electrode patch 15 are also performed.

Following satisfactory completion of the power up sequence, an iterative processing loop (steps 102-109) is continually executed by the microcontroller 61. During each iteration (step 102) of the processing loop, the ECG frontend 63 (shown in FIGURE 9) continually senses the

cutaneous ECG electrical signals (step 103) via the ECG electrodes 38, 29 and is optimized to maintain the integrity of the P-wave. A sample of the ECG signal is read (step 104) by the microcontroller 61 by sampling the analog ECG signal output front end 63. FIGURE 12 is a graph showing, by way of example, a typical ECG waveform 110. The *x*-axis represents time in approximate units of tenths of a second. The *y*-axis represents cutaneous electrical signal strength in approximate units of millivolts. The P-wave 111 has a smooth, normally upward, that is, positive, waveform that indicates atrial depolarization. The QRS complex usually begins with the downward deflection of a Q wave 112, followed by a larger upward deflection of an R-wave 113, and terminated with a downward waveform of the S wave 114, collectively representative of ventricular depolarization. The T wave 115 is normally a modest upward waveform, representative of ventricular depolarization, while the U wave 116, often not directly observable, indicates the recovery period of the Purkinje conduction fibers.

Sampling of the R-to-R interval enables heart rate information derivation. For instance, the R-to-R interval represents the ventricular rate and rhythm, while the P-to-P interval represents the atrial rate and rhythm. Importantly, the PR interval is indicative of atrioventricular (AV) conduction time and abnormalities in the PR interval can reveal underlying heart disorders, thus representing another reason why the P-wave quality achievable by the extended wear ambulatory electrocardiography and physiological sensor monitor described herein is medically unique and important. The long-term observation of these ECG indicia, as provided through extended wear of the wearable monitor 12, provides valuable insights to the patient's cardiac function and overall well-being.

Each sampled ECG signal, in quantized and digitized form, is temporarily staged in buffer (step 105), pending compression preparatory to storage in the flash memory 62 (step 106). Following compression, the compressed ECG digitized sample is again buffered (step 107), then written to the flash memory 62 (step 108) using the communications bus. Processing continues (step 109), so long as the monitoring recorder 14 remains connected to the electrode patch 15 (and storage space remains available in the flash memory 62), after which the processing loop is exited and execution terminates. Still other operations and steps are possible.

In a further embodiment, the monitor recorder 14 also continuously receives data from wearable physiology monitors or activity sensors 131 and mobile devices 133 (shown in FIGURE 3). The data is received in a conceptually-separate execution thread as part of the iterative processing loop (steps 102-109) continually executed by the microcontroller 61. During each iteration (step 102) of the processing loop, if wireless data is available (step 140), a sample of the wireless is read (step 141) by the microcontroller 61 and, if necessary, converted into a

digital signal by the onboard ADC of the microcontroller 61. Each wireless data sample, in quantized and digitized form, is temporarily staged in buffer (step 142), pending compression preparatory to storage in the flash memory 62 (step 143). Following compression, the compressed wireless data sample is again buffered (step 144), then written to the flash memory 62 (step 145) using the communications bus. Processing continues (step 109), so long as the monitoring recorder 14 remains connected to the electrode patch 15 (and storage space remains available in the flash memory 62), after which the processing loop is exited and execution terminates. Still other operations and steps are possible.

The monitor recorder 14 stores ECG data and other information in the flash memory 62 (shown in FIGURE 9) using a proprietary format that includes data compression. As a result, data retrieved from a monitor recorder 14 must first be converted into a format suitable for use by third party post-monitoring analysis software. FIGURE 13 is a flow diagram showing a method 150 for offloading and converting ECG and other physiological data from an extended wear electrocardiography and physiological sensor monitor 12 in accordance with one embodiment. The method 150 can be implemented in software and execution of the software can be performed on a download station 125, which could be a programmer or other device, or a computer system, including a server 122 or personal computer 129, such as further described *supra* with reference to FIGURE 3, as a series of process or method modules or steps. For convenience, the method 150 will be described in the context of being performed by a personal computer 136 or other connectable computing device (shown in FIGURE 3) as middleware that converts ECG data and other information into a format suitable for use by a third-party post-monitoring analysis program. Execution of the method 150 by a computer system would be analogous *mutatis mutandis*.

Initially, the download station 125 is connected to the monitor recorder 14 (step 151), such as by physically interfacing to a set of terminals 128 on a paired receptacle 127 or by wireless connection, if available. The data stored on the monitor recorder 14, including ECG and physiological monitoring data, other recorded data, and other information are retrieved (step 152) over a hard link 135 using a control program 137 (“Ctl”) or analogous application executing on a personal computer 136 or other connectable computing device.

The data retrieved from the monitor recorder 14 is in a proprietary storage format and each datum of recorded ECG monitoring data, as well as any other physiological data or other information, must be converted, so that the data can be used by a third-party post-monitoring analysis program. Each datum of ECG monitoring data is converted by the middleware (steps 153-159) in an iterative processing loop. During each iteration (step 153), the ECG datum is

read (step 154) and, if necessary, the gain of the ECG signal is adjusted (step 155) to compensate, for instance, for relocation or replacement of the electrode patch 15 during the monitoring period.

In addition, depending upon the configuration of the wearable monitor 12, other physiological data (or other information), including patient events, such as a fall, peak activity level, sleep detection, Detection of patient activity levels and states, and so on, may be recorded along with the ECG monitoring data. For instance, actigraphy data may have been sampled by the actigraphy sensor 64 based on a sensed event occurrence, such as a sudden change in orientation due to the patient taking a fall. In response, the monitor recorder 14 will embed the actigraphy data samples into the stream of data, including ECG monitoring data, that is recorded to the flash memory 62 by the micro-controller 61. Post-monitoring, the actigraphy data is temporally matched to the ECG data to provide the proper physiological context to the sensed event occurrence. As a result, the three-axis actigraphy signal is turned into an actionable event occurrence that is provided, through conversion by the middleware, to third party post-monitoring analysis programs, along with the ECG recordings contemporaneous to the event occurrence. Other types of processing of the other physiological data (or other information) are possible.

Thus, during execution of the middleware, any other physiological data (or other information) that has been embedded into the recorded ECG monitoring data is read (step 156) and time-correlated to the time frame of the ECG signals that occurred at the time that the other physiological data (or other information) was noted (step 157). Finally, the ECG datum, signal gain adjusted, if appropriate, and other physiological data, if applicable and as time-correlated, are stored in a format suitable to the backend software (step 158) used in post-monitoring analysis.

In a further embodiment, the other physiological data, if apropos, is embedded within an unused ECG track. For example, the SCP-ENG standard allows multiple ECG channels to be recorded into a single ECG record. The monitor recorder 14, though, only senses one ECG channel. The other physiological data can be stored into an additional ECG channel, which would otherwise be zero-padded or altogether omitted. The backend software would then be able to read the other physiological data in context with the single channel of ECG monitoring data recorded by the monitor recorder 14, provided the backend software implemented changes necessary to interpret the other physiological data. Still other forms of embedding of the other physiological data with formatted ECG monitoring data, or of providing the other physiological data in a separate manner, are possible.

Processing continues (step 159) for each remaining ECG datum, after which the processing loop is exited and execution terminates. Still other operations and steps are possible.

While the invention has been particularly shown and described as referenced to the embodiments thereof, those skilled in the art will understand that the foregoing and other
5 changes in form and detail may be made therein without departing from the spirit and scope.

CLAIMS:

1 1. A computer-implemented system (120) for providing a
2 personal mobile device-triggered medical intervention, comprising:
3 an activity monitor (131) adapted to be used proximal to a patient's
4 body comprising a physiology sensor operable to sense physiological data of
5 the body;
6 a personal mobile device (133), comprising:
7 an application (132) executable by the mobile device (133) and
8 configured to detect an event of potential medical significance within the
9 sensed physiological data; and
10 a wireless transceiver operable to interface the mobile device
11 (133) with an external system and to send notification of a detection of the
12 event; and
13 an extended wear electrocardiography and physiological sensor
14 monitor recorder (14) dispatched by the external system upon receipt of the
15 notification.

1 2. A system (120) according to Claim 1, further comprising at
2 least one of:
3 the activity monitor (131) further adapted to sense the physiological
4 data continuously;
5 the activity monitor (131) further adapted to sense the physiological
6 data non-continuously; and
7 the activity monitor (131) further adapted to sense the physiological
8 data upon patient triggering.

1 3. A system (120) according to Claim 1, wherein the activity
2 monitor (131) is comprised in the mobile device (133).

1 4. A system (120) according to Claim 1, wherein the activity
2 monitor (131) is a device physically independent from the mobile device
3 (133), further comprising:
4 the mobile device (133) operable to be paired with the activity monitor
5 (131) and further comprising:

6 a wireless communications services transceiver operable to
7 interface the mobile device (133) with a telecommunications network (121)
8 upon which the external system is located; and
9 the activity monitor (131) further comprising:
10 a short-range wireless transceiver operable to interface the
11 activity monitor (131) with the mobile device (133) and to relay the
12 notification to the mobile device.

1 5. A system (120) according to Claim 1, wherein the
2 physiological data is selected from the group comprising heart rate,
3 temperature, blood pressure, respiratory rate, blood pressure, blood sugar,
4 oxygen saturation, and minute ventilation.

1 6. A system (120) according to Claim 1, further comprising:
2 the sensor monitor recorder (14) comprising:
3 a sealed housing (50) adapted to be removably secured into the
4 non-conductive receptacle (25) on a disposable extended wear electrode patch
5 (15); and
6 electronic circuitry (60) comprised within the sealed housing
7 (50), comprising:
8 an externally-powered micro-controller (61) operable to
9 execute under micro programmable control;
10 an electrocardiographic front end circuit (63)
11 electrically interfaced to the micro-controller (61) and operable to sense
12 electrocardiographic signals through electrocardiographic electrodes (38, 39)
13 provided on the disposable extended wear electrode patch (15); and
14 an externally-powered flash memory (62) electrically
15 interfaced with the micro-controller (61) and operable to store the samples of
16 the electrocardiographic signals.

1 7. A system (120) according to Claim 6, further comprising:
2 a recorder wireless transceiver (69) electrically interfaced with the
3 micro-controller (61) and operable to interface the mobile device (133) with a
4 telecommunications network (121) upon which electronic medical records
5 (134) are located; and

6 an upload module configured to send the samples of the
7 electrocardiographic signals directly to the electronic medical records (134)
8 via the recorder wireless transceiver (69)..

1 8. A system (120) according to Claim 7, further comprising:
2 a server (122) coupled to the electronic medical records, further
3 comprising:
4 a data retrieval module configured to retrieve the samples of the
5 electrocardiographic signals from the electronic medical records (134); and
6 an evaluation module configured to evaluate the samples of the
7 electrocardiographic signals and to refer the patient (10, 11) for medical care.

1 9. A system (120) according to Claim 7, further comprising:
2 a recording feature comprised in the mobile device (133) operable to
3 record physical indicia proximal to the mobile device (133),
4 wherein a recording of both the placement of the sensor monitor
5 recorder (14) on the patient's body and indicia uniquely identifying the patient
6 are provided to the electronic medical records (134) with the samples of the
7 electrocardiographic signals as certification.

1 10. A system (120) according to Claim 9, further comprising:
2 the sealed housing (50) further comprising indicia uniquely identifying
3 the sensor monitor recorder (14),
4 wherein the recording further comprises the indicia uniquely the sensor
5 monitor recorder (14).

1 11. A system (120) according to Claim 10, wherein the indicia
2 uniquely identifying the sensor monitor recorder (14) is selected from the
3 group comprising visible indicia printed on the outside of the sealed housing
4 (50), visible indicia applied to the outside of the sealed housing (50), and
5 electronic indicia integrated into the sealed housing (50).

1 12. A system (120) according to Claim 7, further comprising:
2 a recording feature comprised in the mobile device (133) operable to
3 record physical indicia proximal to the mobile device (133),

4 wherein a recording of the placement of the sensor monitor recorder on
5 the patient's body and indicia uniquely identifying the patient (10) are
6 securely stored as part of the samples of the electrocardiographic signals as
7 certification.

1 13. A system (120) according to Claim 12, further comprising:
2 the sealed housing (50) further comprising indicia uniquely identifying
3 the sensor monitor recorder (14),
4 wherein the recording further comprises the indicia uniquely the sensor
5 monitor recorder (14).

1 14. A system (120) according to Claim 13, wherein the indicia
2 uniquely the sensor monitor recorder (14) is selected from the group
3 comprising visible indicia printed on the outside of the sealed housing (50),
4 visible indicia applied to the outside of the sealed housing (50), and electronic
5 indicia integrated into the sealed housing (50).

1 15. A system (120) according to Claim 6, further comprising:
2 a download station (125) comprising:
3 a non-conductive receptacle (127) adapted to removably
4 receive the monitor recorder (14); and
5 a download station controller operable to retrieve the samples
6 of the electrocardiographic signals; and
7 a computer system (136) operatively coupled to the download station
8 controller and centrally accessible over a data communications network (121)
9 and operable to maintain the samples of the electrocardiographic signals upon
10 retrieval.

1 16. A system (120) according to Claim 6, further comprising:
2 a pair of electrical contacts (56) external to the sealed housing (50) and
3 electrically connected to at least one of the micro-controller (61), the wireless
4 transceiver (69), and the flash memory (62);
5 a battery (71) provided on the disposable extended wear electrode
6 patch (15); and

7 a pair of electrical pads (34) external to the disposable extended wear
8 electrode patch (15) and disposed to operatively couple with the pair of
9 electrical contacts (56), the electrical pads (34) further electrically interfaced
10 via battery leads to the battery (71).

1 17. A system (120) according to Claim 6, the disposable extended
2 wear electrode patch (15) further comprising:

3 a flexible backing (20) formed of an elongated strip (21) of stretchable
4 material with a narrow longitudinal midsection (23) and, on each end (30, 31),
5 a contact surface at least partially coated with an adhesive dressing provided
6 as a crimp relief;

7 a pair of electrocardiographic electrodes (38, 39) conductively exposed
8 on the contact surface of each end (30, 31) of the elongated strip (21);

9 a non-conductive receptacle (25) adhered to an outward-facing end of
10 the elongated strip (21) and comprising the electrical pads (34); and

11 a flexible circuit (34) affixed on each end (30, 31) of the elongated
12 strip (21) as a strain relief and comprising a pair of circuit traces (33, 37)
13 electrically coupled to the pair of electrocardiographic electrodes (38, 39) and
14 a pair of the electrical pads (34), at least one of the circuit traces (33, 37)
15 adapted to extend along the narrow longitudinal midsection (23) to serve as
16 the strain relief.

1 18. A system (120) according to Claim 1, wherein the activity
2 tracker is selected from the group comprising a wearable physiology sensor, a
3 wearable activity sensor, a smart watch, and a smartphone.

1 19. A system (120) according to Claim 1, further comprising at
2 least one of:

3 a server computer system (122) centrally accessible over a data
4 communications network (121) and operable to wirelessly interface with the
5 wireless transceiver to receive the samples of the electrocardiographic signals;
6 and

7 a client computer system (129) interconnected to the data
8 communications network (121) and operable to wirelessly interface with the
9 wireless transceiver to access the samples of the electrocardiographic signals.

1 20. A system (120) according to Claim 19, further comprising:
2 a secure database (124) interconnected to the data communications
3 network (121) and operable to maintain the samples of the
4 electrocardiographic signals on behalf of one or more of the server computer
5 system (122) and the client computer system (129) in the patient's electronic
6 medical records (134).

7 21. A remotely-interfaceable extended wear electrocardiography
8 and physiological sensor monitor recorder (14), comprising:
9 a sealed housing (50) adapted to be removably secured into a non-
10 conductive receptacle (25) on a disposable extended wear electrode patch (15);
11 and
12 an electronic circuitry (60) comprised within the sealed housing (50),
13 comprising:
14 an externally-powered micro-controller (61) operable to
15 execute under micro programmable control;
16 an electrocardiographic front end circuit (63) electrically
17 interfaced to the micro-controller (61) and operable to sense
18 electrocardiographic signals through electrocardiographic electrodes (38, 39)
19 provided on the disposable extended wear electrode patch (15), each of the
20 electrocardiographic electrodes (38, 39) adapted to be positioned axially along
21 the midline (16) of the sternum (13) for capturing action potential propagation;
22 a wireless transceiver (69) electrically interfaced with the
23 micro-controller (61) and operable to wirelessly interface with an external
24 wireless-enabled device to communicate samples of the electrocardiographic
25 signals; and
26 an externally-powered flash memory (62) electrically interfaced
27 with the micro-controller (61) and operable to store the samples of the
28 electrocardiographic signals.

1 22. An electrocardiography and physiological sensor monitor
2 recorder (14) according to Claim 21, further comprising at least one of:
3 a server computer system (122) centrally accessible over a data
4 communications network (121) and operable to wirelessly interface with the

5 wireless transceiver (69) to receive the samples of the electrocardiographic
6 signals;
7 a client computer system (129) interconnected to the data
8 communications network (121) and operable to wirelessly interface with the
9 wireless transceiver (69) to access the samples of the electrocardiographic
10 signals; and
11 a smart mobile device (133) operable to wirelessly interface with the
12 wireless transceiver (69) to access the samples of the electrocardiographic
13 signals.

1 23. An electrocardiography and physiological sensor monitor
2 recorder (14) according to Claim 21, further comprising:
3 a secure database (124) interconnected to a data communications
4 network (121) and operable to maintain the samples of the
5 electrocardiographic signals on behalf of one or more of the server computer
6 system (122), the client computer system (129), and the smart mobile device
7 (133).

1 24. An electrocardiography and physiological sensor monitor
2 recorder (14) according to Claim 21, further comprising:
3 a download station (125) comprising:
4 a non-conductive receptacle (127) adapted to removably
5 receive the monitor recorder (14); and
6 a download station controller operable to retrieve the samples
7 of the electrocardiographic signals; and
8 a computer system (136) operatively coupled to the download station
9 controller and centrally accessible over a data communications network (121)
10 and operable to maintain the samples of the electrocardiographic signals upon
11 retrieval.

1 25. An electrocardiography and physiological sensor monitor
2 recorder (14) according to Claim 21, further comprising:
3 a pair of electrical contacts (56) external to the sealed housing (50) and
4 electrically connected to at least one of the micro-controller (61), the wireless
5 transceiver (69), and the flash memory (62);

6 a battery (71) provided on the disposable extended wear electrode
7 patch (15); and
8 a pair of electrical pads (34) external to the disposable extended wear
9 electrode patch (15) and disposed to operatively couple with the pair of the
10 electrical contacts (56), the electrical pads (34) further electrically interfaced
11 via battery leads to the battery (71).

1 26. An electrocardiography and physiological sensor monitor
2 recorder (14) according to Claim 21, the disposable extended wear electrode
3 patch (15) further comprising:

4 a flexible backing (20) formed of an elongated strip (21) of stretchable
5 material with a narrow longitudinal midsection (23) and, on each end (30, 31),
6 a contact surface at least partially coated with an adhesive dressing provided
7 as a crimp relief;

8 a pair of electrocardiographic electrodes (38, 39) conductively exposed
9 on the contact surface of each end (30, 31) of the elongated strip (21);

10 a non-conductive receptacle (25) adhered to an outward-facing surface
11 of the elongated strip (21) and comprising the electrical pads (34); and

12 a flexible circuit (32) affixed on each end of the elongated strip as a
13 strain relief and comprising a pair of circuit traces (33, 37) electrically coupled
14 to the pair of electrocardiographic electrodes (38, 39) and a pair of the
15 electrical pads (34), at least one of the circuit traces (33, 37) adapted to extend
16 along the narrow longitudinal midsection (23) to serve as the strain relief.

1 27. A remotely-interfaceable extended wear electrocardiography
2 and physiological sensor monitor (12), comprising:

3 a disposable extended wear electrode patch (15) comprising:

4 a flexible backing (20) formed of an elongated strip (21) of
5 stretchable material with a narrow longitudinal midsection (23) and, on each
6 end (30, 31), a contact surface at least partially coated with an adhesive
7 dressing provided as a crimp relief;

8 a pair of electrocardiographic electrodes (38, 39) conductively
9 exposed on the contact surface of each end of the elongated strip (21),
10 respectively;

11 a non-conductive receptacle (25) adhered to an outward-facing
12 surface of the elongated strip (21) and comprising a plurality of electrical pads
13 (34); and

14 a flexible circuit (32) affixed on each end of the elongated strip
15 (21) as a strain relief and comprising a pair of circuit traces (33, 37)
16 electrically coupled to the pair of the electrocardiographic electrodes (38, 39)
17 and a pair of the electrical pads (34), at least one of the circuit traces (38, 39)
18 adapted to extend along the narrow longitudinal midsection (23) to serve as
19 the strain relief; and

20 a reusable electrocardiography monitor (14) having a sealed housing
21 (50) adapted to be removably secured into the non-conductive receptacle (25)
22 and comprising:

23 a micro-controller (61) operable to execute under micro
24 programmable control and electrically interfaced to an electrocardiographic
25 front end circuit (63) that is operable to sense electrocardiographic signals
26 through the electrocardiographic electrodes (38, 39) via the pair of the
27 electrical pads (34);

28 a wireless transceiver (69) electrically interfaced with the
29 micro-controller (61) and operable to wirelessly interface with an external
30 wireless-enabled device to communicate samples of the electrocardiographic
31 signals; and

32 a flash memory (62) electrically interfaced with the micro-
33 controller (61) and operable to store the samples of the electrocardiographic
34 signals.

1 28. An electrocardiography and physiological sensor monitor (12)
2 according to Claim 27, wherein the electrocardiographic front end circuit (63)
3 is optimized to sense P-wave (111) signals in the electrocardiographic signals.

1 29. An electrocardiography and physiological sensor monitor (12)
2 according to Claim 27, further comprising at least one of:

3 a server computer system (122) centrally accessible over a data
4 communications network (121) and operable to wirelessly interface with the

5 wireless transceiver (69) to receive the samples of the electrocardiographic
6 signals;
7 a client computer system (129) interconnected to the data
8 communications network (121) and operable to wirelessly interface with the
9 wireless transceiver (69) to access the samples of the electrocardiographic
10 signals; and
11 a smart mobile device (133) operable to wirelessly interface with the
12 wireless transceiver (69) to access the samples of the electrocardiographic
13 signals.

1 30. An electrocardiography and physiological sensor monitor (12)
2 according to Claim 27, further comprising:
3 a secure database (124) interconnected to a data communications
4 network (121) and operable to maintain the samples of the
5 electrocardiographic signals on behalf of one or more of the server computer
6 system (122), the client computer system (129), and the smart mobile device
7 (133).

1 31. An electrocardiography and physiological sensor monitor (12)
2 according to Claim 27, further comprising:
3 a wearable physiology sensor (131), comprising:
4 a housing adapted to be removably worn by a patient along
5 with the disposable extended wear electrode patch (15); and
6 an electronic circuitry comprised within the housing and
7 comprising a sensor operable to sense physiology and a wireless transceiver
8 electrically interfaced with the sensor and operable to wirelessly interface with
9 the reusable electrocardiography monitor (14) to communicate samples of the
10 physiology sensed by the wearable physiology sensor (131).

1 32. An electrocardiography and physiological sensor monitor (12)
2 according to Claim 27, further comprising:
3 a download station (125) comprising:
4 a non-conductive receptacle (127) adapted to removably
5 receive the monitor recorder; and

6 a download station controller operable to retrieve the samples
7 of the electrocardiographic signals; and
8 a computer system (136) operatively coupled to the download station
9 controller and centrally accessible over a data communications network (121)
10 and operable to maintain the samples of the electrocardiographic signals upon
11 retrieval.

1 33. An electrocardiography and physiological sensor monitor (12)
2 according to Claim 27, further comprising:

3 a battery (71) comprised on the disposable extended wear electrode
4 patch (15) and electrically interfaced via battery leads to a pair of the electrical
5 pads (34); and at least one of:

6 the micro-controller (61) operable to draw power from the
7 battery (71) via the pair of the electrical pads (34); and

8 the flash memory (61) operable to draw power from the battery
9 (71) via the pair of the electrical pads (34).

1 34. An electrocardiography and physiological sensor monitor
2 according to Claim 27, further comprising:

3 a battery (71) comprised on the disposable extended wear electrode
4 patch (15) and electrically interfaced via battery leads to a pair of the electrical
5 pads (34), the capacity of the battery (71) being selected to support additional
6 electrical components without affecting operation of the reusable
7 electrocardiography monitor (14).

1 35. An electrocardiography and physiological sensor monitor (12)
2 according to Claim 27, further comprising:

3 an expansion bus (68) operatively interconnected to the micro-
4 controller (61) and electrically coupled to at least one of the electrical pads
5 (34);

6 a physiology sensor comprised within the disposable extended wear
7 electrode patch (15) and operable to sense physiology and to draw power from
8 the battery (71) via the battery leads, the physiology sensor electrically
9 interfaced with the micro-controller over the expansion bus (68); and

10 the flash memory (62) further operable through the expansion bus (68)
11 to store samples of the physiology sensed detected by the physiology sensor.

1 36. An electrocardiography and physiological sensor monitor (12)
2 according to Claim 35, wherein the physiology sensor is selected from the
3 group comprising an SpO₂ sensor, a blood pressure sensor, a temperature
4 sensor, a respiratory rate sensor, a glucose sensor, an air flow sensor, and a
5 volumetric pressure sensor.

1 37. An electrocardiography and physiological sensor monitor
2 according to Claim 27, further comprising:
3 an expansion bus (68) operatively interconnected to the micro-
4 controller (61);
5 a physiology sensor comprised within the reusable electrocardiography
6 monitor (14) and operable to sense physiology and to draw power from the
7 battery (71) via the pair of the electrical pads (34), the physiology sensor
8 electrically interfaced with the micro-controller (61) over the expansion bus
9 (68); and

10 the flash memory (62) further operable through the expansion bus (68)
11 to store samples of the physiology sensed detected by the physiology sensor.

1 38. An electrocardiography and physiological sensor monitor
2 according to Claim 37, wherein the physiology sensor is selected from the
3 group comprising an SpO₂ sensor, a blood pressure sensor, a temperature
4 sensor, a respiratory rate sensor, a glucose sensor, an air flow sensor, and a
5 volumetric pressure sensor.

1 39. An electrocardiography and physiological sensor monitor (12)
2 according to Claim 27, further comprising:
3 an actigraphy sensor (64) comprised within the reusable
4 electrocardiography monitor (14) and operable to detect movement, the
5 actigraphy sensor electrically interfaced with the micro-controller (61); and
6 the flash memory (62) further operable to store samples of the
7 movement detected by the actigraphy sensor (64).

1 40. An electrocardiography and physiological sensor monitor (12)
2 according to Claim 27, further comprising at least one of:
3 a feedback output component (66) comprised in the reusable
4 electrocardiography monitor (14) and electrically interfaced with the micro-
5 controller (61); and
6 a feedback input component (55, 66) comprised in the reusable
7 electrocardiography monitor (14) and externally wearer-operable from outside
8 the sealed housing (50), the feedback input (55, 66) further electrically
9 interfaced with the micro-controller (61).

1/8

Fig. 1.

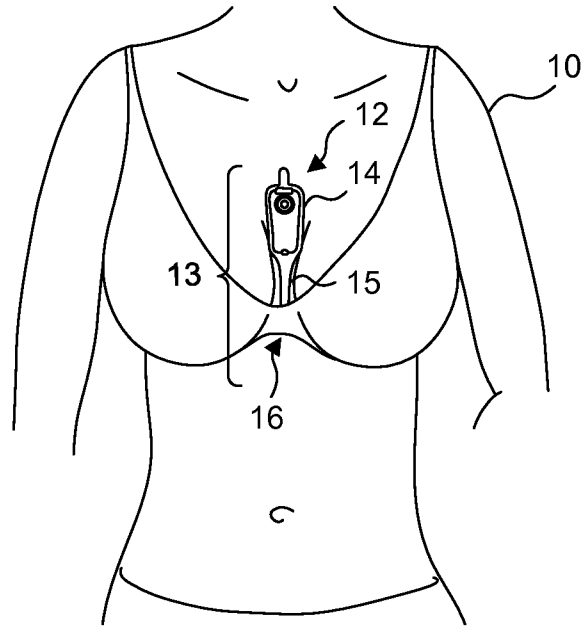

Fig. 2.

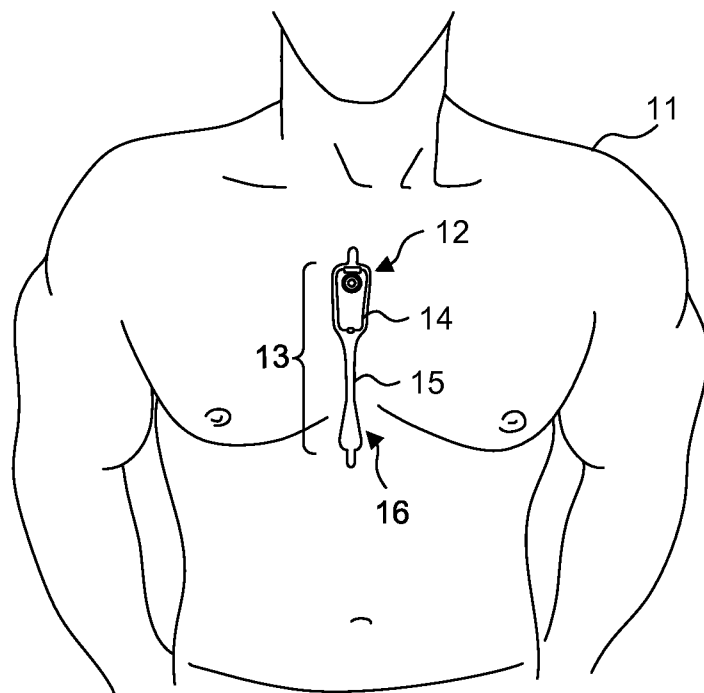

Fig. 3.

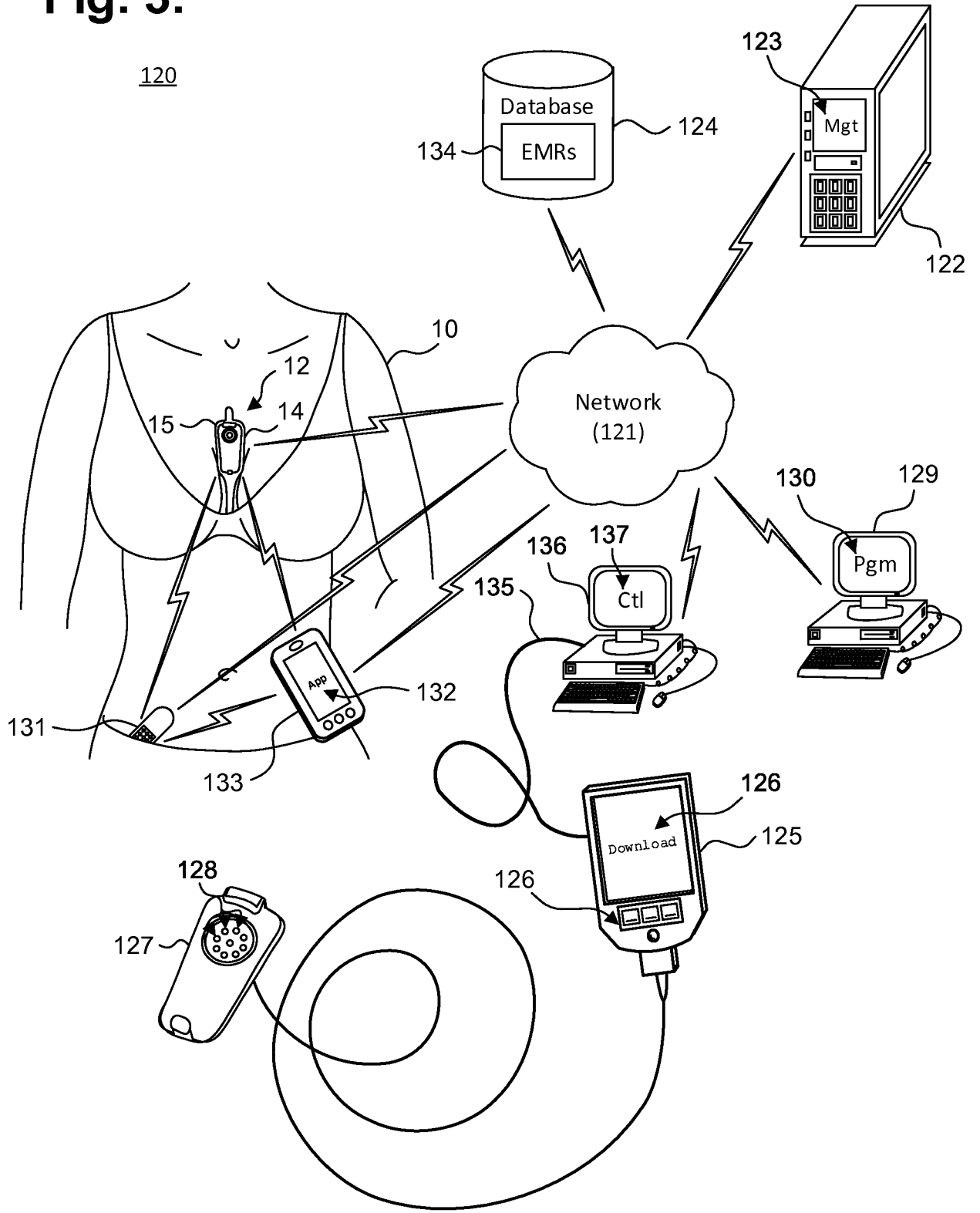

Fig. 4.

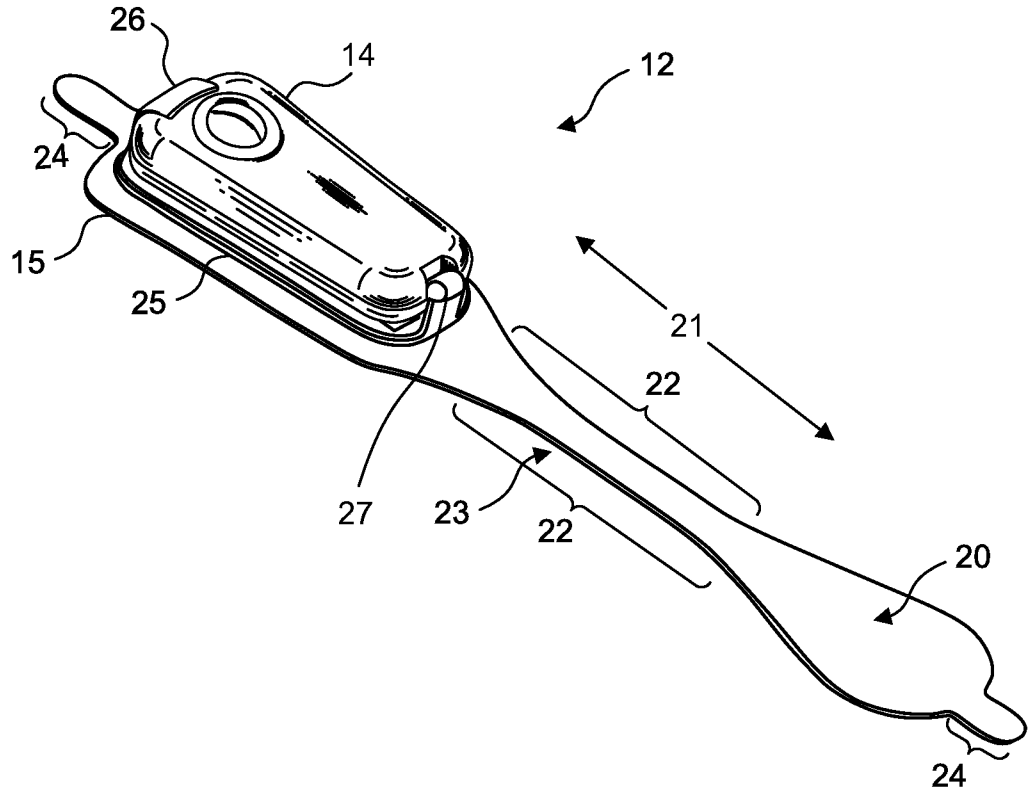

Fig. 5.

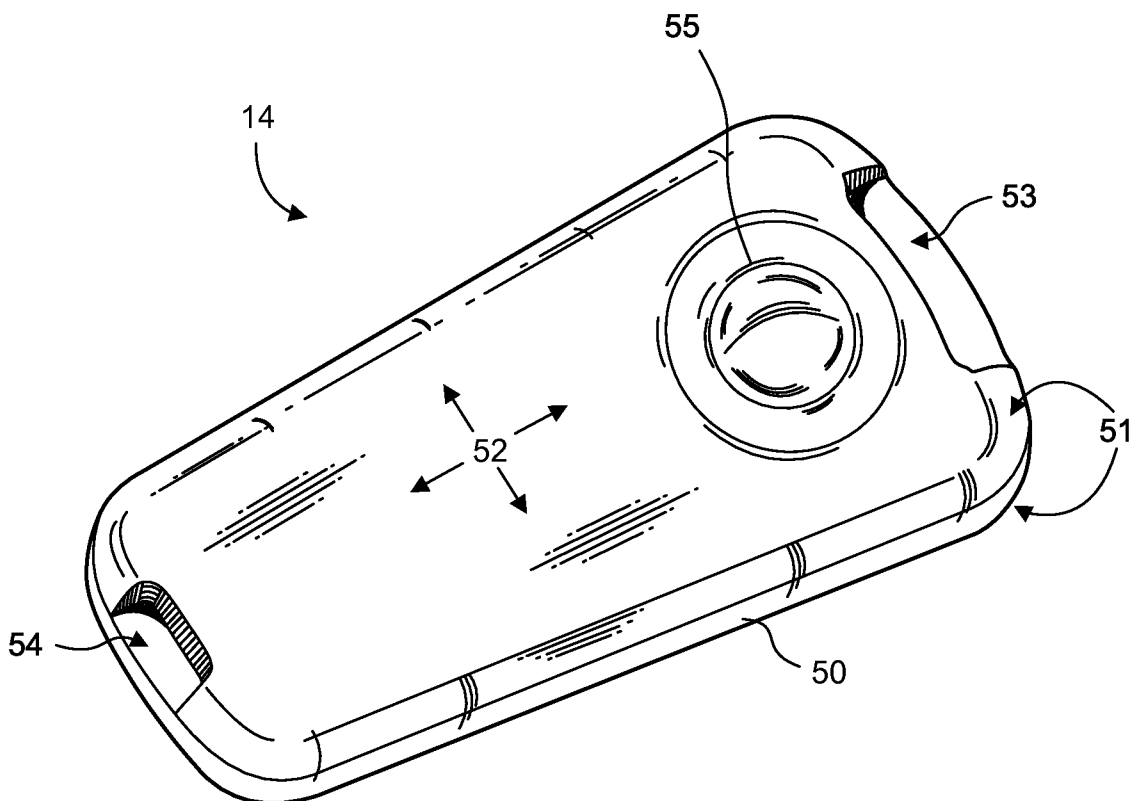

Fig. 6.

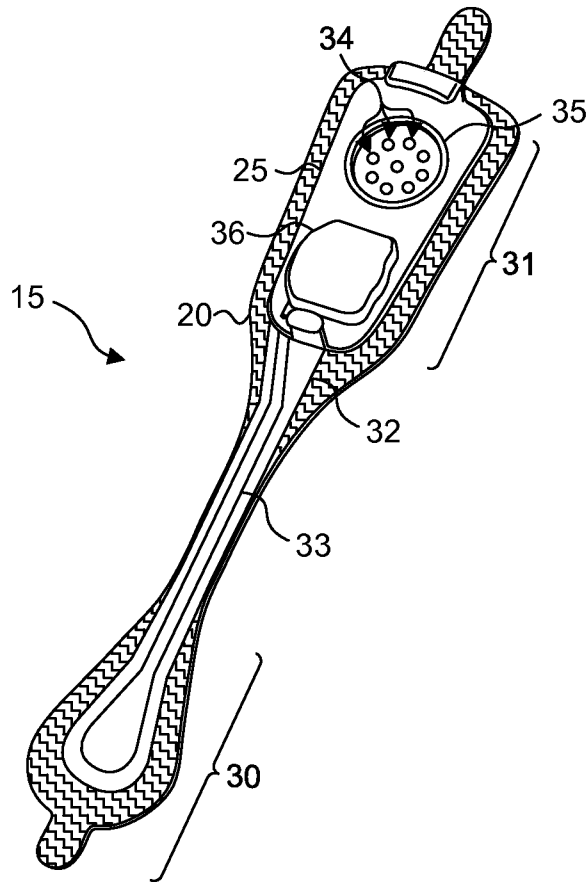

Fig. 7.

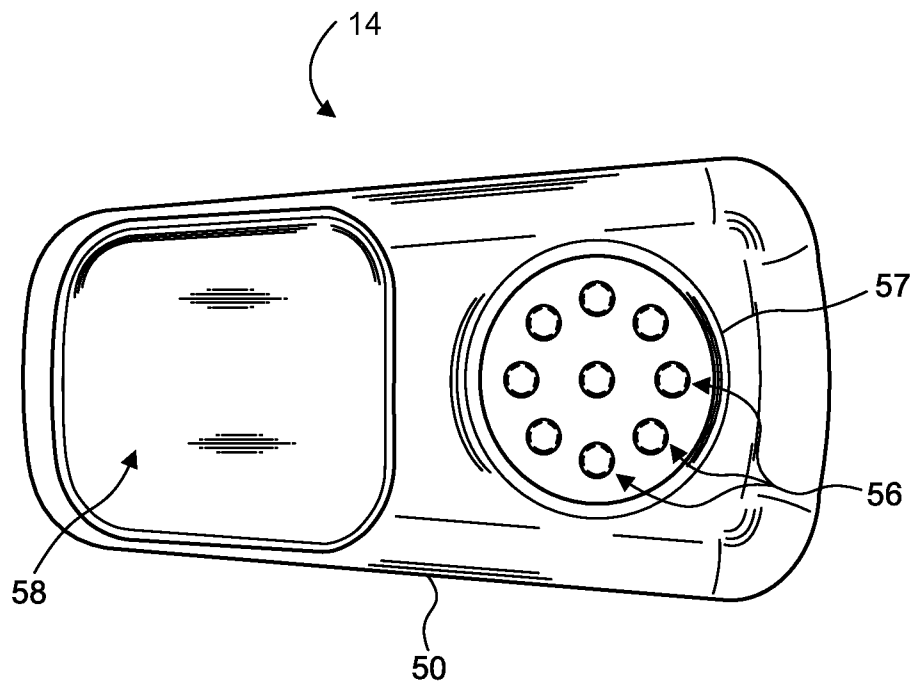

Fig. 8.

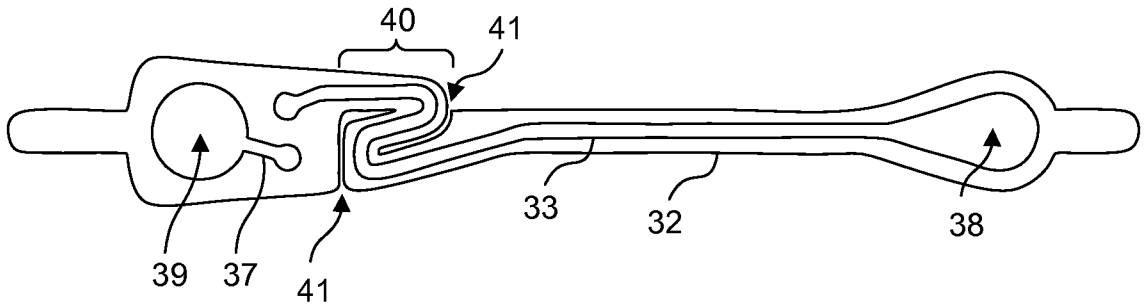

Fig. 9.

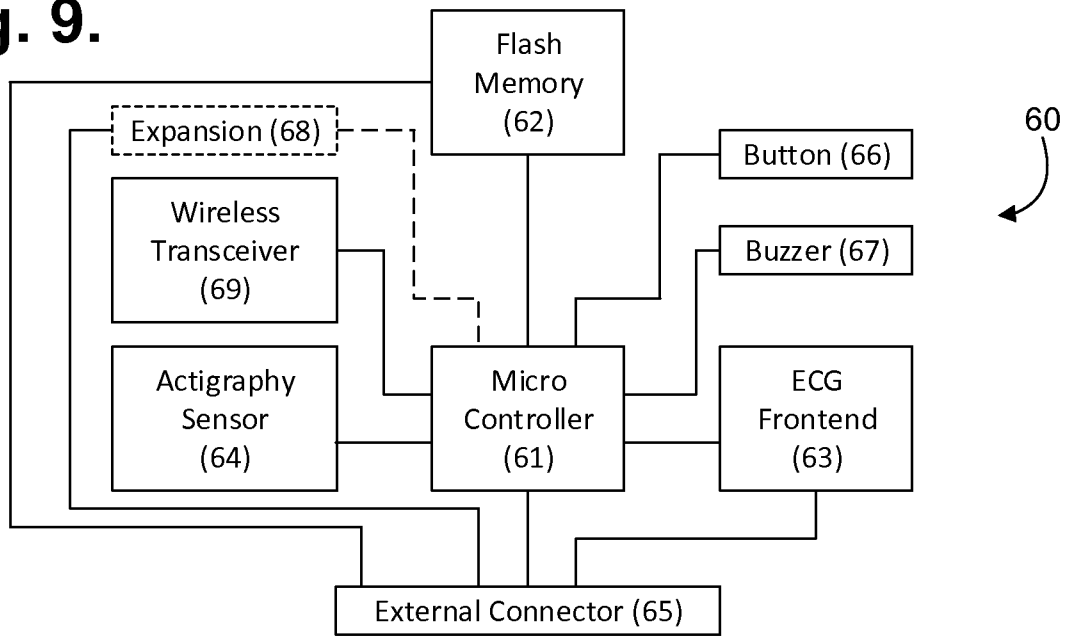
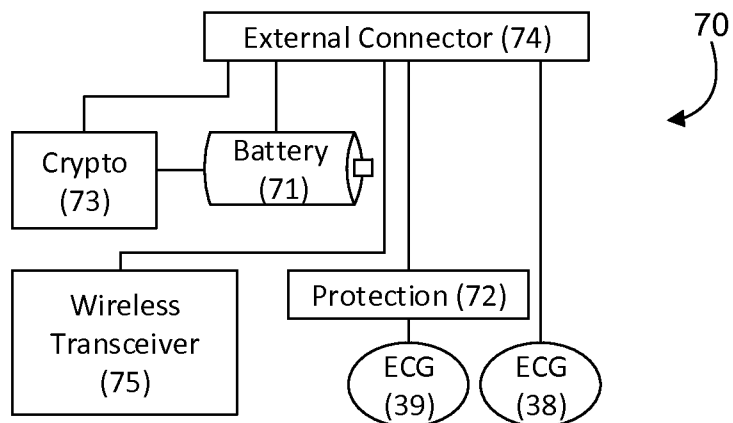

Fig. 10.



6/8

Fig. 11.

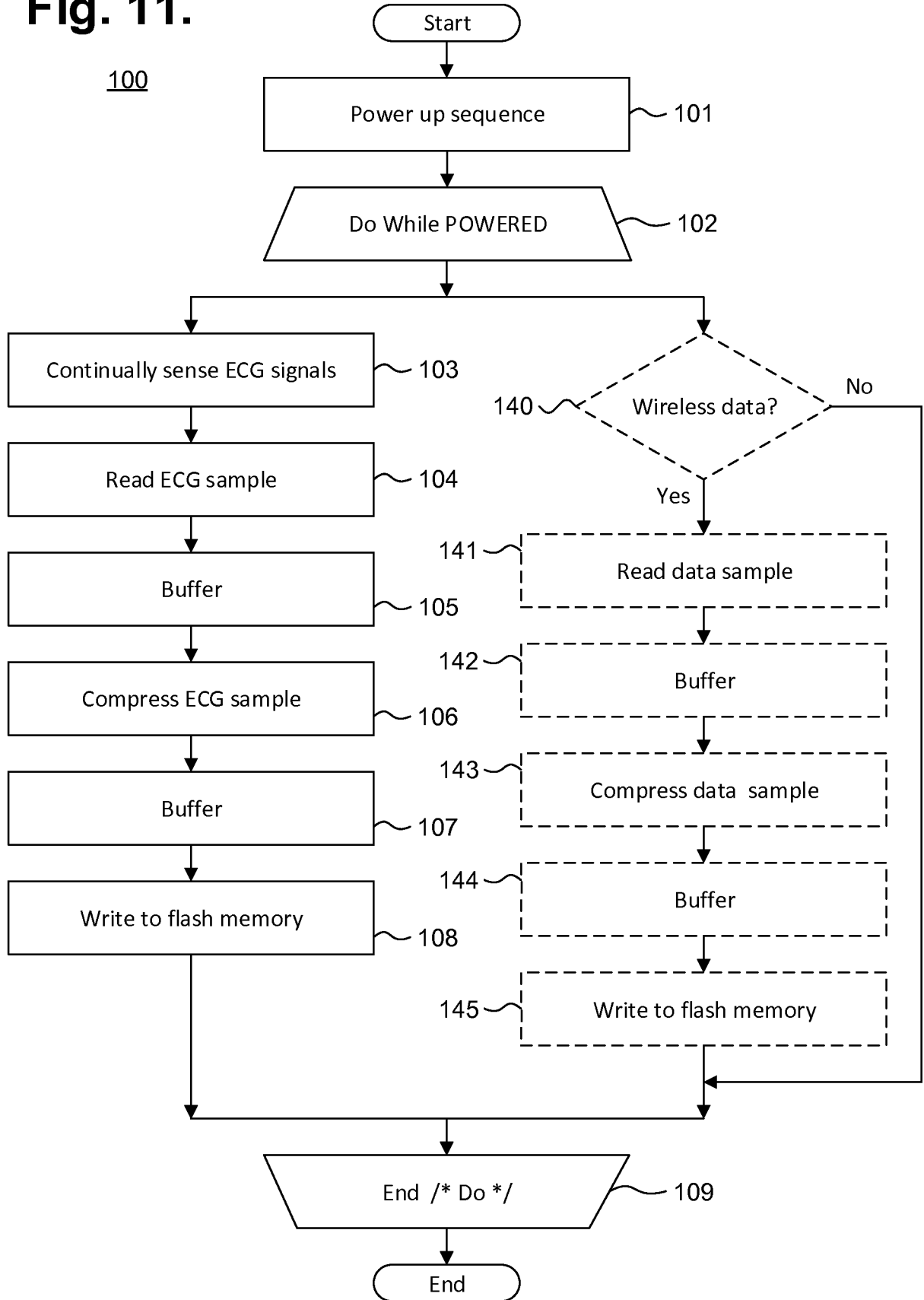

Fig. 12.

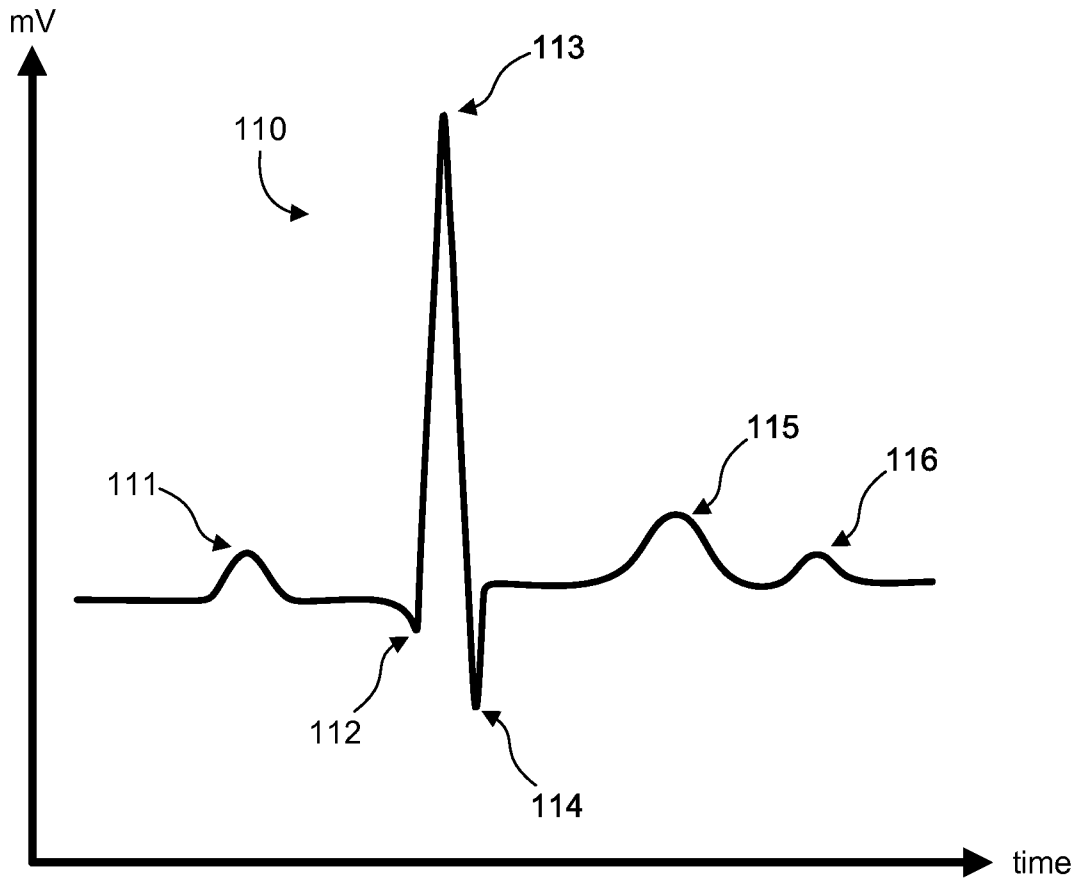
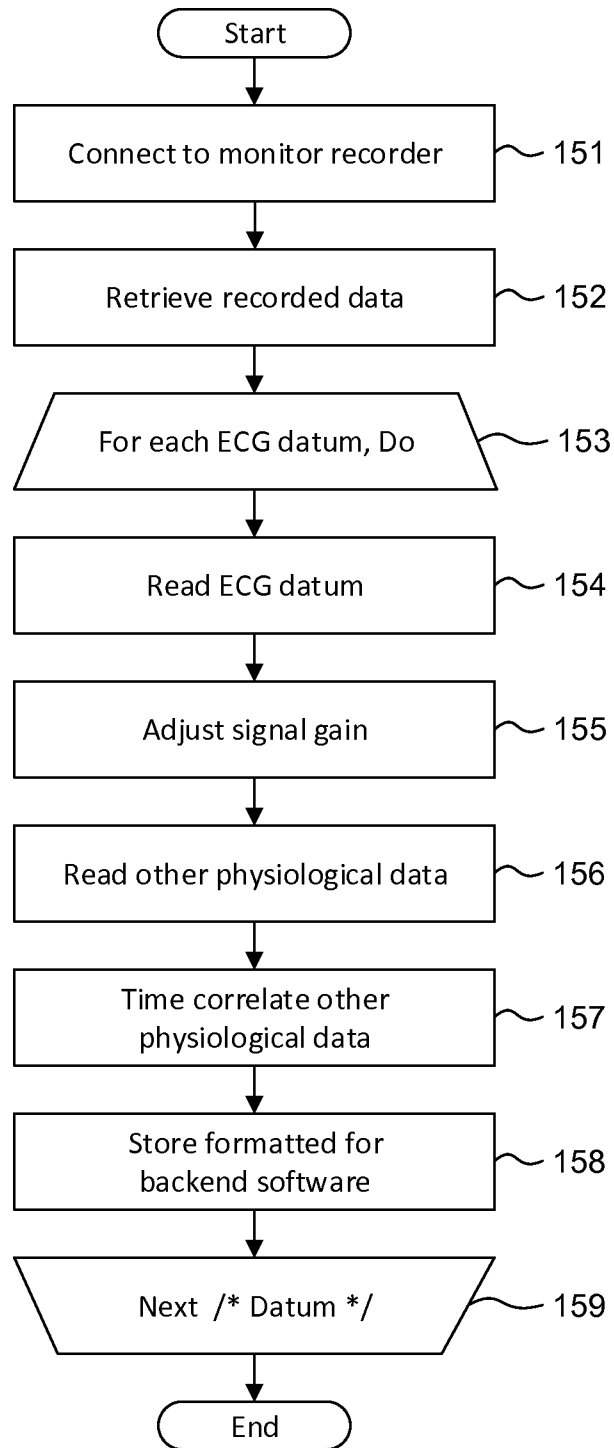

Fig. 13.

150



INTERNATIONAL SEARCH REPORT

International application No
PCT/US2014/057505

A. CLASSIFICATION OF SUBJECT MATTER
INV. A61B5/00 A61B5/024
ADD.
According to International Patent Classification (IPC) or to both national classification and IPC

B. FIELDS SEARCHED
Minimum documentation searched (classification system followed by classification symbols)
A61B

Documentation searched other than minimum documentation to the extent that such documents are included in the fields searched

Electronic data base consulted during the international search (name of data base and, where practicable, search terms used)
EPO-Internal, WPI Data

C. DOCUMENTS CONSIDERED TO BE RELEVANT

Category*	Citation of document, with indication, where appropriate, of the relevant passages	Relevant to claim No.
X	WO 2012/146957 A1 (KONINKL PHILIPS ELECTRONICS NV [NL]; TEN KATE WARNER RUDOLPH THEOPHILE) 1 November 2012 (2012-11-01)	1-5, 18-20
Y	page 5, line 10 - line 13 page 9, line 3 page 9, line 23 - line 32 page 11, line 12 - line 22 page 13, line 6 - line 11	6-17
X	US 2009/076397 A1 (LIBBUS IMAD [US] ET AL) 19 March 2009 (2009-03-19)	21-40
Y	paragraph [0047] - paragraph [0052]	6-17
A	paragraph [0057] - paragraph [0066] paragraph [0072] paragraph [0079] paragraph [0083] paragraph [0090]	19,20
	----- -/--	

Further documents are listed in the continuation of Box C.

See patent family annex.

* Special categories of cited documents :

- "A" document defining the general state of the art which is not considered to be of particular relevance
- "E" earlier application or patent but published on or after the international filing date
- "L" document which may throw doubts on priority claim(s) or which is cited to establish the publication date of another citation or other special reason (as specified)
- "O" document referring to an oral disclosure, use, exhibition or other means
- "P" document published prior to the international filing date but later than the priority date claimed

- "T" later document published after the international filing date or priority date and not in conflict with the application but cited to understand the principle or theory underlying the invention
- "X" document of particular relevance; the claimed invention cannot be considered novel or cannot be considered to involve an inventive step when the document is taken alone
- "Y" document of particular relevance; the claimed invention cannot be considered to involve an inventive step when the document is combined with one or more other such documents, such combination being obvious to a person skilled in the art
- "&" document member of the same patent family

Date of the actual completion of the international search 19 December 2014	Date of mailing of the international search report 08/01/2015
---	--

Name and mailing address of the ISA/ European Patent Office, P.B. 5818 Patentlaan 2 NL - 2280 HV Rijswijk Tel. (+31-70) 340-2040, Fax: (+31-70) 340-3016	Authorized officer Gooding Arango, J
--	---

INTERNATIONAL SEARCH REPORT

International application No
PCT/US2014/057505

C(Continuation). DOCUMENTS CONSIDERED TO BE RELEVANT		
Category*	Citation of document, with indication, where appropriate, of the relevant passages	Relevant to claim No.
A	WO 2012/140559 A1 (MEDIC4ALL AG [CH]; SHMUELI RAM [IL]; SANDLERMAN NIMROD [IL]) 18 October 2012 (2012-10-18) abstract; figure 1A -----	1-40
A	US 2012/095352 A1 (TRAN BAO [US]) 19 April 2012 (2012-04-19) paragraph [0358] -----	1-40
A	US 2002/013538 A1 (TELLER DAVID [US]) 31 January 2002 (2002-01-31) paragraph [0015] paragraph [0044] paragraph [0116] paragraph [0146] -----	1-40
A	US 2007/208233 A1 (KOVACS GREGORY T [US] KOVACS GREGORY T A [US]) 6 September 2007 (2007-09-06) paragraph [0067] - paragraph [0071] -----	1-40
A	ALEXANDER M. CHAN ET AL: "Wireless patch sensor for remote monitoring of heart rate, respiration, activity, and falls", 2013 35TH ANNUAL INTERNATIONAL CONFERENCE OF THE IEEE ENGINEERING IN MEDICINE AND BIOLOGY SOCIETY (EMBC), 1 July 2013 (2013-07-01), pages 6115-6118, XP055157468, DOI: 10.1109/EMBC.2013.6610948 ISBN: 978-1-45-770216-7 page 1, column 2, paragraph 3 -----	1-40
A	DORTHE B SAADI ET AL: "Heart Rhythm Analysis using ECG recorded with a Novel Sternum based Patch Technology -A Pilot Study", CARDIOTECHNIX 2013 - INTERNATIONAL CONGRESS ON CARDIOVASCULAR TECHNOLOGIES, 20 September 2013 (2013-09-20), XP055157450, Section 1.2 -----	1-40

INTERNATIONAL SEARCH REPORT

Information on patent family members

International application No PCT/US2014/057505

Patent document cited in search report	Publication date	Patent family member(s)	Publication date
WO 2012146957	A1	01-11-2012	CN 103493113 A
			CN 103503041 A
			EP 2702575 A1
			EP 2702576 A1
			JP 2014518666 A
			JP 2014518668 A
			US 2014142460 A1
			US 2014191863 A1
			WO 2012146957 A1
			WO 2012147036 A1

US 2009076397	A1	19-03-2009	US 2009076397 A1
			WO 2009036319 A1

WO 2012140559	A1	18-10-2012	NONE

US 2012095352	A1	19-04-2012	US 2007273504 A1
			US 2009227876 A1
			US 2012095352 A1
			US 2014143064 A1

US 2002013538	A1	31-01-2002	NONE

US 2007208233	A1	06-09-2007	CN 101583305 A
			US 2007208233 A1

专利名称(译)	提供个人移动设备触发的医疗干预		
公开(公告)号	EP3048954A1	公开(公告)日	2016-08-03
申请号	EP2014781024	申请日	2014-09-25
[标]申请(专利权)人(译)	BARDY诊断		
申请(专利权)人(译)	BARDY诊断, INC.		
当前申请(专利权)人(译)	BARDY诊断, INC.		
[标]发明人	BARDY GUST H FELIX JASON BISHAY JON MIKALSON		
发明人	BARDY, GUST H. FELIX, JASON BISHAY, JON MIKALSON		
IPC分类号	A61B5/00 A61B5/024		
CPC分类号	A61B5/024 A61B5/7282 G06F19/3418 A61B5/0022 A61B5/0205 G06F19/00 G16H40/63		
优先权	61/882403 2013-09-25 US 14/080725 2013-11-14 US 14/080717 2013-11-14 US 14/082071 2013-11-15 US 14/217402 2014-03-17 US		
外部链接	Espacenet		

摘要(译)

可以通过可穿戴监视器 (12) 提供生理监测, 该可穿戴监视器包括两个部件, 柔性延伸耐磨电极贴片 (15) 和可拆卸可重复使用监视器记录器 (14)。将监护仪 (12) 放置在胸骨中线 (16) 的位置 (或紧靠胸骨的任一侧) 有利于延长磨损, 因为在整个监测过程中不需要将ECG电极连续放置在相同的位置。监视器 (12) 可以与其他生理和活动传感器 (131) 和移动设备 (132) 无线地互操作。由传感器 (131) 或设备 (133) 执行的应用程序 (132) 可以在检测到潜在的医学上重要的事件时触发将可穿戴监视器 (12) 发送给患者。然后, 监视器 (12) 能够提供精确的医学上可操作的数据。然后, 患者 (10,11) 可以使用传感器 (131) 或设备 (133) 来记录监视器 (12) 的放置和使用。