



(12) **EUROPEAN PATENT APPLICATION**

(88) Date of publication A3:
20.05.2020 Bulletin 2020/21

(51) Int Cl.:
A61B 5/0402 (2006.01) **A61B 5/00** (2006.01)
A61B 5/0205 (2006.01) **A61B 5/0408** (2006.01)
A61B 5/0432 (2006.01) **A61B 5/1455** (2006.01)
A61B 5/024 (2006.01) **A61B 5/11** (2006.01)
A61B 5/0456 (2006.01)

(43) Date of publication A2:
15.04.2020 Bulletin 2020/16

(21) Application number: **19194996.5**

(22) Date of filing: **07.10.2013**

(84) Designated Contracting States:
AL AT BE BG CH CY CZ DE DK EE ES FI FR GB GR HR HU IE IS IT LI LT LU LV MC MK MT NL NO PL PT RO RS SE SI SK SM TR

(72) Inventors:

- **Golda, George Stefan**
EL GRANADA, CA California CA 94018 (US)
- **Moyer, Daniel Van Zandt**
Menlo Park, CA California CA 9402 (US)
- **Marriott, Mark P.**
Palo Alto, CA California CA 94301 (US)
- **Eletr, Sam**
Kensington, CA California CA 94707 (US)
- **O'Neil, Bruce**
San Francisco, CA California CA 94115 (US)

(30) Priority: **07.10.2012 US 201261710768 P**
15.03.2013 US 201313837748

(62) Document number(s) of the earlier application(s) in accordance with Art. 76 EPC:
13843561.5 / 2 903 509

(71) Applicant: **Rhythm Diagnostic Systems Inc.**
San Francisco, California 94118 (US)

(74) Representative: **ZBM Patents - Zea, Barlocchi & Markvardsen**
Rambla Catalunya, 123
08008 Barcelona (ES)

(54) **WEARABLE CARDIAC MONITOR**

(57) Systems, methods and devices for reducing noise in cardiac monitoring including wearable monitoring devices having at least one electrode for cardiac monitoring; in some implementations, the wearable device using a composite adhesive having at least one conductive portion applied adjacent the electrode; and, in some implementations, including circuitry adaptations for the at least one electrode to act as a proxy driven right leg electrode.

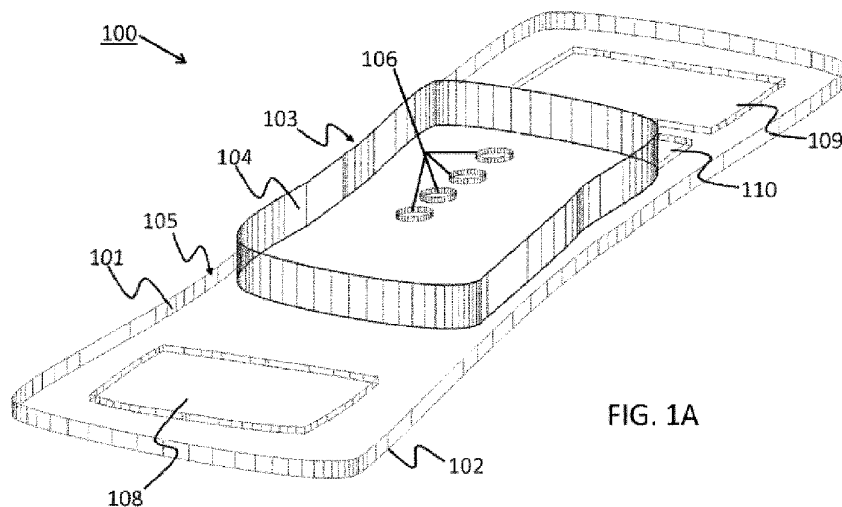

FIG. 1A

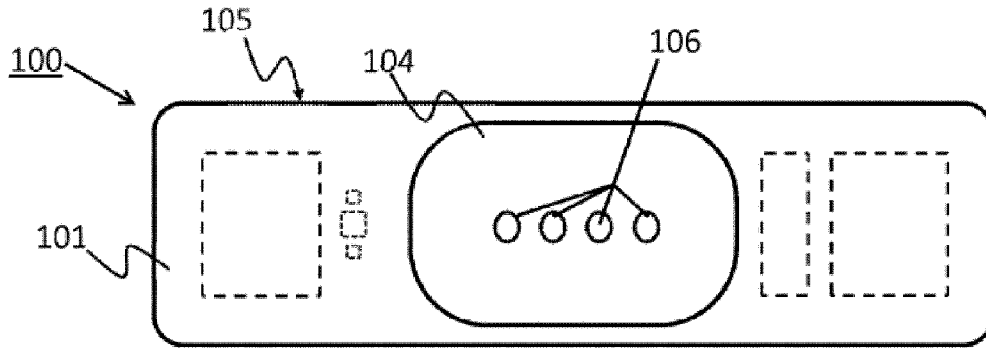

FIG. 1B

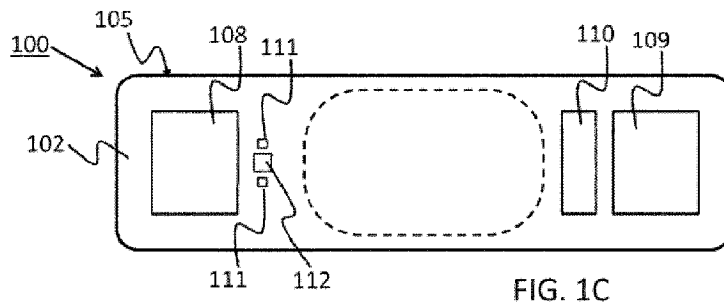

FIG. 1C

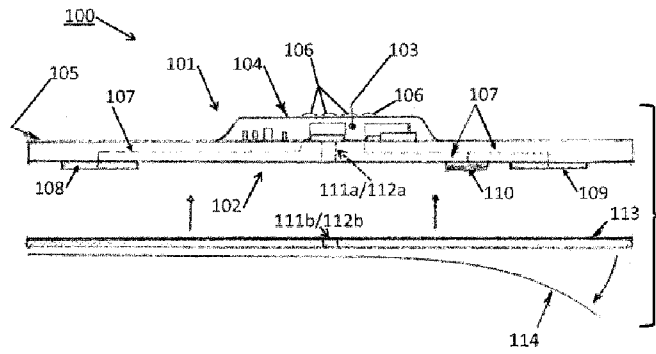

FIG. 1D

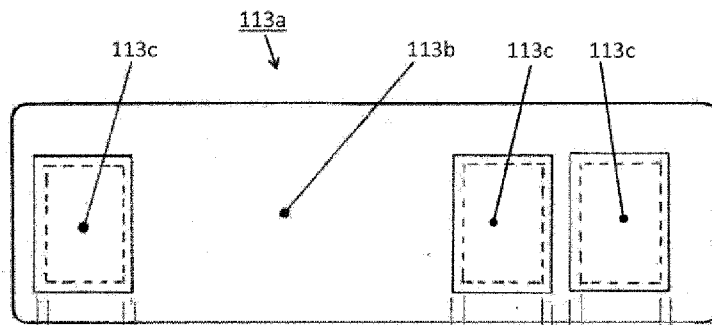
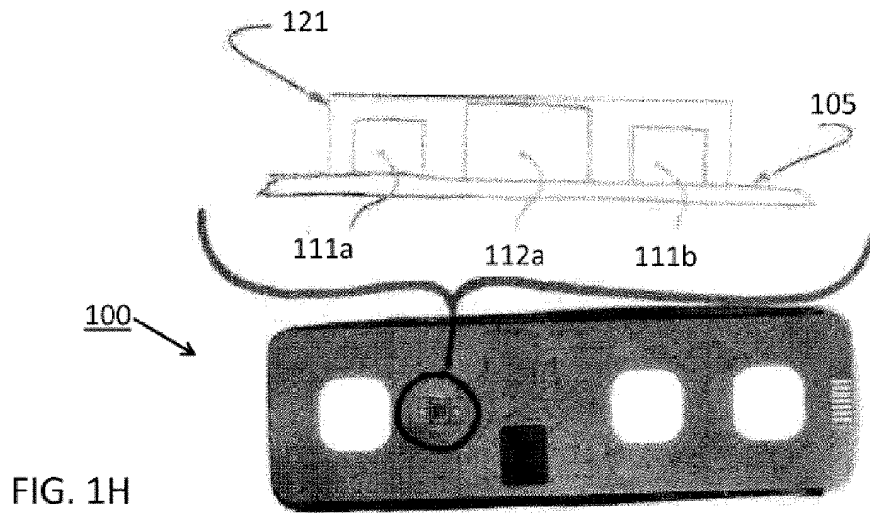
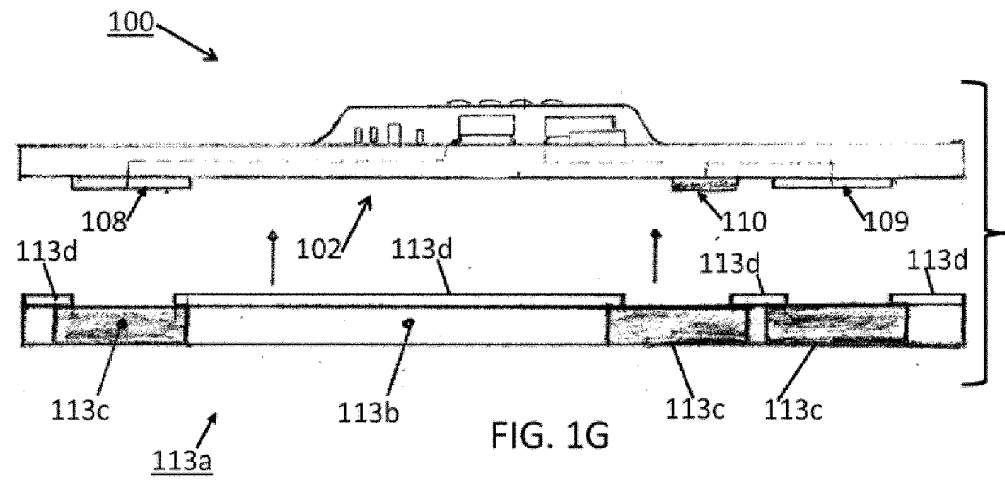
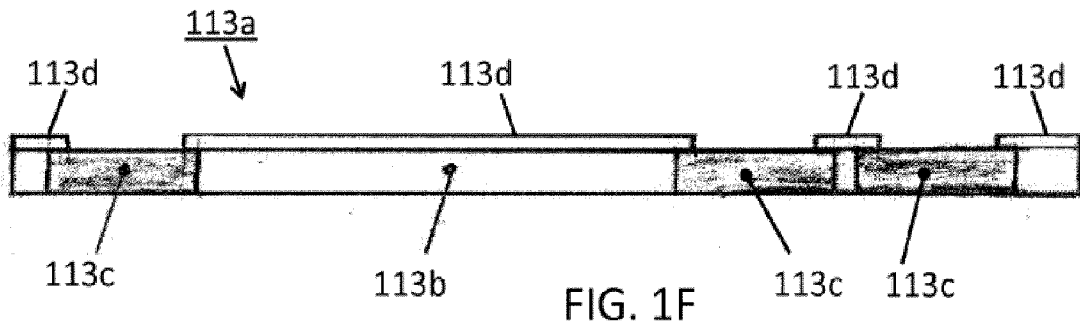

FIG. 1E





EUROPEAN SEARCH REPORT

Application Number
EP 19 19 4996

5

DOCUMENTS CONSIDERED TO BE RELEVANT			
Category	Citation of document with indication, where appropriate, of relevant passages	Relevant to claim	CLASSIFICATION OF THE APPLICATION (IPC)
X	US 2007/255184 A1 (SHENNIB ADNAN [US]) 1 November 2007 (2007-11-01) * abstract; figures 1-12 * * paragraphs [0025] - [0030], [0045] - [0061] * -----	1-9	INV. A61B5/0402 A61B5/00 A61B5/0205 A61B5/0408 A61B5/0432 A61B5/1455
X	US 2010/317958 A1 (BECK JAMES [US] ET AL) 16 December 2010 (2010-12-16) * abstract; figures 1-6 * * paragraphs [0021] - [0091] * -----	1-9	ADD. A61B5/024 A61B5/11 A61B5/0456
X	US 2006/224072 A1 (SHENNIB ADNAN [US]) 5 October 2006 (2006-10-05) * abstract; figures 1-9 * * paragraphs [0022], [0023], [0033] - [0050] * -----	1-9	
A	US 5 938 597 A (STRATBUCKER ROBERT A [US]) 17 August 1999 (1999-08-17) * abstract; figures 1-7 * * column 14, line 20 - column 20, line 47 * -----	1-9	TECHNICAL FIELDS SEARCHED (IPC)
A	WO 2008/092098 A2 (LIFESYNC CORP A DELAWARE CORP [US]) 31 July 2008 (2008-07-31) * figure 1 * * paragraphs [0054] - [0078] * -----	1-9	A61B H03F
A	US 2008/139953 A1 (BAKER STEVEN D [US] ET AL) 12 June 2008 (2008-06-12) * abstract; figures 1-14 * * paragraphs [0010], [0011], [0040] - [0046], [0048], [0049], [0069] - [0072], [0077] - [0081], [0089], [0095] - [0098] * ----- -/--	1-9	
The present search report has been drawn up for all claims			
Place of search The Hague		Date of completion of the search 31 March 2020	Examiner Carta, Riccardo
CATEGORY OF CITED DOCUMENTS X : particularly relevant if taken alone Y : particularly relevant if combined with another document of the same category A : technological background O : non-written disclosure P : intermediate document		T : theory or principle underlying the invention E : earlier patent document, but published on, or after the filing date D : document cited in the application L : document cited for other reasons & : member of the same patent family, corresponding document	

EPO FORM 1503 03.82 (P04C01)

10

15

20

25

30

35

40

45

50

55



EUROPEAN SEARCH REPORT

Application Number
EP 19 19 4996

5

10

15

20

25

30

35

40

45

50

55

DOCUMENTS CONSIDERED TO BE RELEVANT			
Category	Citation of document with indication, where appropriate, of relevant passages	Relevant to claim	CLASSIFICATION OF THE APPLICATION (IPC)
X	US 2010/324389 A1 (MOON JIM [US] ET AL) 23 December 2010 (2010-12-23) * abstract; figures 7-13 * * paragraphs [0060] - [0095] * -----	10-15	
T	SUREKHA PALREDDY ED - WEBSTER J G: "Chapter 9. Signal Processing Algorithms", 1 January 1997 (1997-01-01), DESIGN OF PULSE OXIMETERS; [MEDICAL SCIENCE SERIES], BRISTOL [U.A.] : INSTITUTE OF PHYSICS PUB, GB, PAGE(S) 124 - 158, XP008127836, ISBN: 978-0-7503-0467-2 * page 133 - page 157 * -----	10-15	
X	US 5 971 930 A (ELGHAZZAWI ZIAD [US]) 26 October 1999 (1999-10-26) * abstract; figure 1 * * column 3, line 15 - column 4, line 55 * -----	10-15	
The present search report has been drawn up for all claims			TECHNICAL FIELDS SEARCHED (IPC)
Place of search The Hague		Date of completion of the search 31 March 2020	Examiner Carta, Riccardo
CATEGORY OF CITED DOCUMENTS X : particularly relevant if taken alone Y : particularly relevant if combined with another document of the same category A : technological background O : non-written disclosure P : intermediate document		T : theory or principle underlying the invention E : earlier patent document, but published on, or after the filing date D : document cited in the application L : document cited for other reasons & : member of the same patent family, corresponding document	

3 EPO FORM 1503 03.82 (P04C01)



Application Number

EP 19 19 4996

5

CLAIMS INCURRING FEES

The present European patent application comprised at the time of filing claims for which payment was due.

10

Only part of the claims have been paid within the prescribed time limit. The present European search report has been drawn up for those claims for which no payment was due and for those claims for which claims fees have been paid, namely claim(s):

15

No claims fees have been paid within the prescribed time limit. The present European search report has been drawn up for those claims for which no payment was due.

20

LACK OF UNITY OF INVENTION

The Search Division considers that the present European patent application does not comply with the requirements of unity of invention and relates to several inventions or groups of inventions, namely:

25

see sheet B

30

All further search fees have been paid within the fixed time limit. The present European search report has been drawn up for all claims.

35

As all searchable claims could be searched without effort justifying an additional fee, the Search Division did not invite payment of any additional fee.

40

Only part of the further search fees have been paid within the fixed time limit. The present European search report has been drawn up for those parts of the European patent application which relate to the inventions in respect of which search fees have been paid, namely claims:

45

None of the further search fees have been paid within the fixed time limit. The present European search report has been drawn up for those parts of the European patent application which relate to the invention first mentioned in the claims, namely claims:

50

55

The present supplementary European search report has been drawn up for those parts of the European patent application which relate to the invention first mentioned in the claims (Rule 164 (1) EPC).



**LACK OF UNITY OF INVENTION
SHEET B**

Application Number
EP 19 19 4996

5

The Search Division considers that the present European patent application does not comply with the requirements of unity of invention and relates to several inventions or groups of inventions, namely:

10

1. claims: 1-9

Flexible adhesive patch for monitoring physiological parameters of a patient

15

2. claims: 10-15

Method of measuring oxygen saturation of a subject by combining ECG and pulse oximetry signals

20

25

30

35

40

45

50

55

ANNEX TO THE EUROPEAN SEARCH REPORT
ON EUROPEAN PATENT APPLICATION NO.

EP 19 19 4996

5

This annex lists the patent family members relating to the patent documents cited in the above-mentioned European search report. The members are as contained in the European Patent Office EDP file on The European Patent Office is in no way liable for these particulars which are merely given for the purpose of information.

31-03-2020

10

15

20

25

30

35

40

45

50

Patent document cited in search report	Publication date	Patent family member(s)	Publication date
US 2007255184 A1	01-11-2007	US 2007255184 A1 WO 2007095455 A2	01-11-2007 23-08-2007
US 2010317958 A1	16-12-2010	US 2010317958 A1 US 2015073231 A1 WO 2008148067 A2	16-12-2010 12-03-2015 04-12-2008
US 2006224072 A1	05-10-2006	NONE	
US 5938597 A	17-08-1999	NONE	
WO 2008092098 A2	31-07-2008	EP 2109397 A2 US 2013345539 A1 US 2016166170 A1 WO 2008092098 A2	21-10-2009 26-12-2013 16-06-2016 31-07-2008
US 2008139953 A1	12-06-2008	CN 101534706 A EP 2081488 A2 US 2008139953 A1 US 2012238890 A1 US 2014100467 A1 US 2014243694 A1 US 2015126848 A1 US 2016029917 A1 US 2016029918 A1 US 2016354003 A1 US 2018146877 A1 US 2019110709 A1 WO 2008057884 A2	16-09-2009 29-07-2009 12-06-2008 20-09-2012 10-04-2014 28-08-2014 07-05-2015 04-02-2016 04-02-2016 08-12-2016 31-05-2018 18-04-2019 15-05-2008
US 2010324389 A1	23-12-2010	EP 2442709 A1 SG 176892 A1 SG 10201404148W A US 2010324384 A1 US 2010324385 A1 US 2010324386 A1 US 2010324387 A1 US 2010324388 A1 US 2010324389 A1 US 2014088385 A1 US 2018042495 A1 US 2019029534 A1 US 2019029536 A1 WO 2010148205 A1	25-04-2012 30-01-2012 26-09-2014 23-12-2010 23-12-2010 23-12-2010 23-12-2010 23-12-2010 23-12-2010 23-12-2010 27-03-2014 15-02-2018 31-01-2019 31-01-2019 23-12-2010
US 5971930 A	26-10-1999	AT 292413 T	15-04-2005

EPO FORM P0459

For more details about this annex : see Official Journal of the European Patent Office, No. 12/82

55

**ANNEX TO THE EUROPEAN SEARCH REPORT
ON EUROPEAN PATENT APPLICATION NO.**

EP 19 19 4996

5 This annex lists the patent family members relating to the patent documents cited in the above-mentioned European search report.
The members are as contained in the European Patent Office EDP file on
The European Patent Office is in no way liable for these particulars which are merely given for the purpose of information.

31-03-2020

10

15

20

25

30

35

40

45

50

55

Patent document cited in search report	Publication date	Patent family member(s)	Publication date
		CA 2250331 A1	17-04-1999
		DE 69829621 T2	09-02-2006
		EP 0913121 A1	06-05-1999
		JP 4338242 B2	07-10-2009
		JP H1192217 A	21-07-1999
		US 5971930 A	26-10-1999

EPO FORM P0459

For more details about this annex : see Official Journal of the European Patent Office, No. 12/82

专利名称(译)	穿戴式心脏监护仪		
公开(公告)号	EP3636148A3	公开(公告)日	2020-05-20
申请号	EP2019194996	申请日	2013-10-07
[标]申请(专利权)人(译)	RHYTHM诊断SYST		
申请(专利权)人(译)	RHYTHM诊断系统INC.		
当前申请(专利权)人(译)	RHYTHM诊断系统INC.		
[标]发明人	GOLDA GEORGE STEFAN MOYER DANIEL VAN ZANDT MARRIOTT MARK P ELETR SAM ONEIL BRUCE		
发明人	GOLDA, GEORGE STEFAN MOYER, DANIEL VAN ZANDT MARRIOTT, MARK P. ELETR, SAM O'NEIL, BRUCE		
IPC分类号	A61B5/0402 A61B5/00 A61B5/0205 A61B5/0408 A61B5/0432 A61B5/1455 A61B5/024 A61B5/11 A61B5/0456		
CPC分类号	A61B5/0002 A61B5/0006 A61B5/0059 A61B5/0205 A61B5/02125 A61B5/02141 A61B5/02438 A61B5/ /0261 A61B5/0295 A61B5/0402 A61B5/04085 A61B5/04087 A61B5/04325 A61B5/0456 A61B5/08 A61B5/11 A61B5/1118 A61B5/14551 A61B5/14552 A61B5/6828 A61B5/72 A61B5/7207 A61B5/721 A61B5/7214 A61B5/7275 A61B2560/0295 A61B2560/0412 A61B5/6833		
优先权	61/710768 2012-10-07 US 13/837748 2013-03-15 US PCT/US2013/063748 2013-10-07 WO		
其他公开文献	EP3636148A2		
外部链接	Espacenet		

摘要(译)

用于减少心脏监测中的噪声的系统，方法和设备，包括具有至少一个用于心脏监测的电极的可穿戴监测设备；在一些实施方式中，可穿戴设备使用复合粘合剂，该复合粘合剂具有在电极附近施加的至少一个导电部分；在一些实施方式中，包括至少一个电极充当驱动驱动的右腿电极的电路适配。

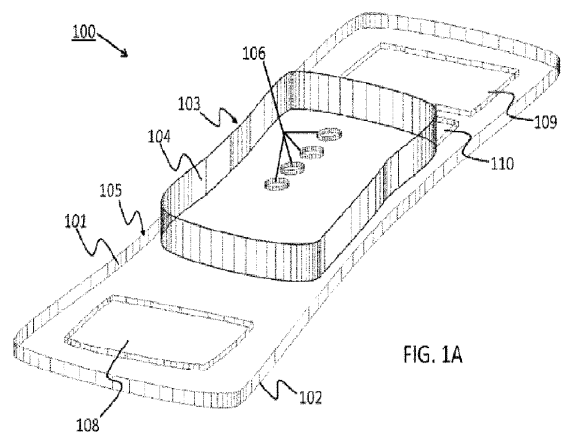

FIG. 1A