



(12) **EUROPEAN PATENT APPLICATION**

(43) Date of publication:  
**30.05.2018 Bulletin 2018/22**

(51) Int Cl.:  
**A61B 5/1455** <sup>(2006.01)</sup> **A61B 5/00** <sup>(2006.01)</sup>  
**A61B 5/0476** <sup>(2006.01)</sup>

(21) Application number: **17203241.9**

(22) Date of filing: **23.11.2017**

(84) Designated Contracting States:  
**AL AT BE BG CH CY CZ DE DK EE ES FI FR GB GR HR HU IE IS IT LI LT LU LV MC MK MT NL NO PL PT RO RS SE SI SK SM TR**  
 Designated Extension States:  
**BA ME**  
 Designated Validation States:  
**MA MD**

(72) Inventors:  
 • **KIM, Kwang Moo**  
**13525 Seongnam-si (KR)**  
 • **HONG, Seung Kyun**  
**16084 Uiwang-si (KR)**  
 • **CHOI, Sang Woo**  
**14231 Gwangmyeong-si (KR)**  
 • **LEE, Kyu Hong**  
**17046 Yongin-si, (KR)**

(30) Priority: **28.11.2016 KR 20160158908**

(74) Representative: **Wablat Lange Karthaus**  
**Anwaltssozietät**  
**Potsdamer Chaussee 48**  
**14129 Berlin (DE)**

(71) Applicant: **Charm Engineering Co., Ltd.**  
**Gyeonggi-do 17118 (KR)**

(54) **SENSOR FOR DEPTH OF ANESTHESIA AND CEREBRAL BLOOD OXYGEN SATURATION**

(57) Provided is an integrated depth-of-anesthesia/cerebral-oxygen-saturation detection sensor. Particularly, the depth-of-anesthesia/cerebral-oxygen-saturation detection sensor includes a strap and a sensing unit that is arranged on the strap, and sensing unit includes a

depth-of-anesthesia sensor and a cerebral oxygen saturation sensor that are arranged on the same plane. Therefore, it is possible to simultaneously measure a depth of anesthesia and cerebral oxygen saturation with a single detection sensor, so that it is possible to reduce cost.

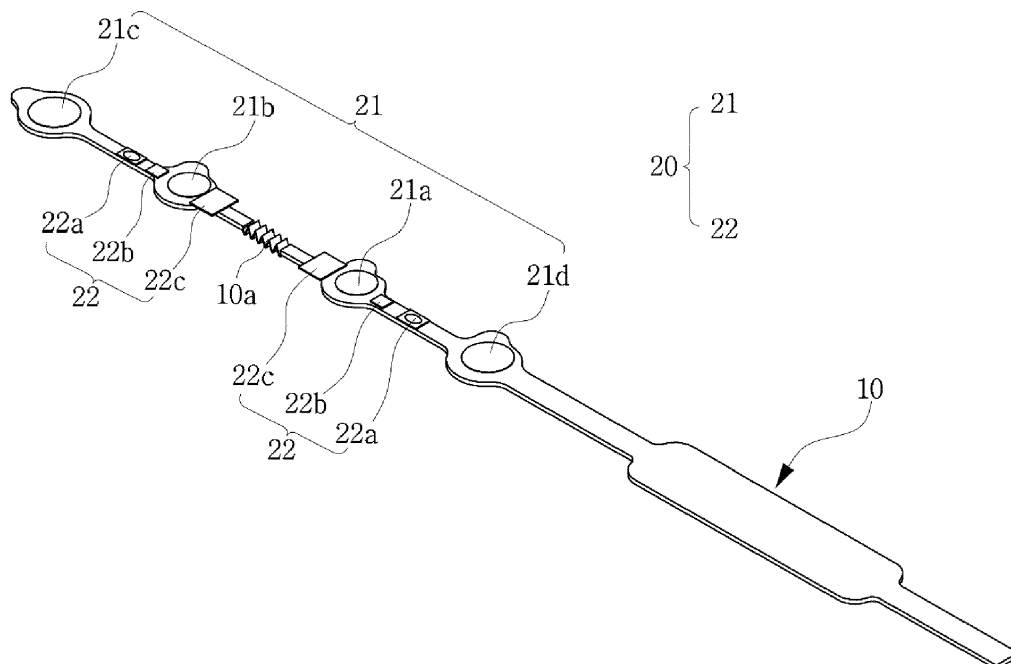

**FIG. 1**

**Description**

[Disclosure]

[Technical Field]

[Technical Problem]

**[0001]** The present invention relates to an integrated depth-of-anesthesia/cerebral oxygen saturation detection sensor, and more particularly, to an integrated depth-of-anesthesia/cerebral oxygen saturation detection sensor capable of measuring a depth of anesthesia and cerebral oxygen saturation with a single sensor.

5 **[0007]** The present invention is conceived to solve the above-described problems in the related art, and an object of the present invention is to an integrated depth-of-anesthesia/cerebral-oxygen-saturation detection sensor where a depth-of-anesthesia sensor and a cerebral oxygen saturation sensor are installed on a single strap, so that a depth of anesthesia and cerebral oxygen saturation can be measured by the single sensor at the same time.

10

[Background Art]

[Technical Solution]

**[0002]** Generally, if a subject (patient) suffers from pain during medical care such as surgery and treatment or skin care, the pain is eliminated or reduced by blocking neurotransmission through anesthetics.

15 **[0008]** In order to achieve the above object, according to an aspect of the present invention, there is provided an integrated depth-of-anesthesia/cerebral-oxygen-saturation detection sensor including a strap and a sensing unit arranged on the strap, wherein the sensing unit includes a depth-of-anesthesia sensor and a cerebral oxygen saturation sensor which are arranged on the same plane.

20

**[0003]** In particular, If surgery is performed on a patient having a sever disease or symptom, the patient needs to be put under general anesthetics to remove all of the body reactions. In addition, the patient's anesthetized state needs to be continuously monitored under such general anesthetics.// In other words, the patient's anesthetized state needs to be checked by detecting the depth of anesthesia, and the operation needs to be performed in a sufficiently anesthetized state so as to prevent a problem in that the patient experiences psychological distress due to awakening during surgery. Currently, the detection of the depth of anesthesia is performed by attaching an EEG sensor to a human body and then collecting and amplifying biological signals including high and low potential differences.

25

**[0009]** Herein, the depth-of-anesthesia sensor may include a ground electrode; and a reference electrode that is arranged to be separated from the ground electrode; and first and second measurement electrodes that are arranged on two sides of the ground electrode and the reference electrode so that the ground electrode and the reference electrode are located between the ground electrode and the reference electrode,

30

**[0004]** On the other hand, cerebral oxygen saturation indicating oxygen saturation of cortical tissues is used as an important parameter in clinical field such as hypoxia, neonatal monitoring, or emergency medicine and, particularly, the cerebral oxygen saturation is very important in clinical management of critically ill patients. Currently, the detection of the cerebral oxygen saturation is performed by attaching a sensor to a human body and then emitting red light and near-infrared light to detect a degree of oxidation of hemoglobin.

35

**[0010]** In addition, the cerebral oxygen saturation sensor may include: a pair of light sources that irradiate a head with red light and near-infrared light having different wavelengths; a pair of first light detection units that receives light reflected from head skin or skull; and a pair of second light detection unit that receives light reflected from brain.

40

**[0005]** Both of the depth-of-anesthesia sensor or the cerebral oxygen saturation sensor are important means to effectively monitor an awakened level of a patient. Since the two sensors are manufactured as separate products and are individually used, the sensors are cumbersome in terms of usage, and it is difficult to integrally monitor the patient's awakened level.

45

**[0011]** In addition, the pair of light sources may be located between the first measurement electrode and the reference electrode and between the second measurement electrode and the ground electrode, and the pair of first light detection units may be arranged between the light source and the reference electrode and between the light source and the ground electrode, and the pair of second light detection unit may be located to be separated from each other between the reference electrode and the ground electrode.

50

[Cited Literature]

**[0012]** In addition, the strap may be formed to have wrinkles in a portion where the depth-of-anesthesia sensor and the cerebral oxygen saturation sensor are not arranged.

55

[Patent Document]

[Advantageous Effects]

**[0006]** Korean Patent Application No. 10-2010-0035977 (Registration No. 10-1079785, titled, "Electroencephalogram Analyzer for Calculating Depth of Anesthesia Index)

**[0013]** In an integrated depth-of-anesthesia/cerebral oxygen saturation detection sensor having the above-described configuration according to the present inven-

tion, a depth-of-anesthesia sensor and a cerebral oxygen saturation sensor are provided on a single strap, and thus, since a depth of anesthesia and cerebral oxygen saturation can be measured at the same time, the detection sensor can be conveniently used, and since there is no need to separately manufacture detection sensors for measuring the depth of anesthesia and the cerebral oxygen saturation, it is possible to advantageously reduce cost.

[Description of Drawings]

**[0014]**

Fig. 1 is a perspective view of an integrated depth-of-anesthesia/cerebral-oxygen-saturation detection sensor according to the present invention.

Fig. 2 is a view illustrating a use state of the integrated depth-of-anesthesia/cerebral-oxygen-saturation detection sensor according to the present invention.

[Best Mode]

**[0015]** Hereinafter, embodiments of an integrated depth-of-anesthesia/cerebral-oxygen-saturation detection sensor according to the present invention will be described in detail with reference to the accompanying drawings.

**[0016]** Fig. 1 is a perspective view illustrating an integrated depth-of-anesthesia/cerebral-oxygen-saturation detection sensor according to the present invention, and Fig. 2 is a view illustrating a use state of the integrated depth-of-anesthesia/cerebral-oxygen-saturation detection sensor according to the present invention.

**[0017]** An integrated depth-of-anesthesia/cerebral-oxygen-saturation detection sensor according to the present invention is configured to include a strap 10 and a sensing unit 20 arranged on the strap 10.

**[0018]** A material of the strap 10 needs to be selected in consideration of characteristics of a human body, particularly, the head of the human body to which the integrated depth-of-anesthesia/cerebral-oxygen-saturation detection sensor according to the present invention are attached.

**[0019]** Namely, in consideration of the fact that the surface of the head is not flat but curved, a material that is flexible so as to be easily bended and folded needs be selected, a material that is highly adhesive to the human body so as to be well adhered to the forehead or scalp and to be well detached needs to be selected, and a material that does not irritate the human body even if the strap is frequently attached and detached needs to be selected to manufacture the strap. Particularly, the above-mentioned effect can be obtained by using a hydrogel which is capable of adhering to the human body several times and, at the same time, not causing irritation to the skin.

**[0020]** The sensing unit 20 is configured to include a depth-of-anesthesia sensor 21 and a cerebral oxygen saturation sensor 22. The depth-of-anesthesia sensor 21 and the cerebral oxygen saturation sensor 22 are arranged on the same plane.

**[0021]** The depth-of-anesthesia sensor 21 is configured to include a ground electrode 21a, a reference electrode 21b, and first and second measurement electrodes 21c and 21d that are arranged on two sides of the ground electrode 21a and the reference electrode 21b so as to be located between the ground electrode 21a and the reference electrode 21b.

**[0022]** The ground electrode 21a is in contact with a portion of the human body for electrical safety of the subject during the measurement of the biological signal, so that the subject is maintained to be in the grounded state. In other words, the ground electrode 21a prevents a safety accident caused by an abnormal voltage during the measurement of the biological signal, and when a fault current occurs, the ground electrode performs a function of discharging the current quickly to the outside of the human body to suppress an increase in an abnormal potential and ensuring the electrical safety of the subject. The ground electrode 21a is provided on one side of the strap 10.

**[0023]** The reference electrode 21b is an electrode as a reference for measuring a biological signal and is provided as a reference for measuring a potential difference between the first and second measurement electrodes 21c and 21d. The reference electrode 21b is provided on one side of the strap 10 and is separated from the ground electrode 21a by a predetermined distance.

**[0024]** The first measurement electrode 21c is attached to the head of the human body and senses a biological signal in the anesthetized state or during the anesthetic operation to measure and detect brain waves generated in the head. The first measurement electrode 21c is arranged at one of the two sides of the reference electrode 21b and is arranged at a position separated from the ground electrode 21a.

Similarly to the first measurement electrode 21c, the second measurement electrode 21d is attached to the head of the human body and senses a biological signal in the anesthetized state or during the anesthetic operation to measure and detect brain waves generated in the head.// Since the measurement electrodes performs the function of measuring and detecting the biological signal, collecting and analyzing the biological signal in a wider range is more advantageous in consideration of the precision and efficiency of the measurement. Particularly, in the case where the brain waves are measured by the measurement electrodes like the present invention, it is preferable that the brain waves of the left brain and right brain are measured. Therefore, when the first measurement electrode 21c measures the brain waves of the left brain, it is preferable that the second measurement electrode 21d measures the brain waves.

**[0025]** Accordingly, the second measurement elec-

trode 21d is arranged so as to be separated from the first measurement electrode 21c as far as possible. That is, the second measurement electrode 21d is arranged on one of the two side of the ground electrode 21a and is arranged at a position separated from the first measurement electrode 21c.

**[0026]** The cerebral oxygen saturation sensor 22 irradiates the red light and the near-infrared light, calculates the ratio of the reflected red light and infrared light components, and then estimates the oxygen saturation based on the calculated ratio of the red light and infrared light components. The cerebral oxygen saturation sensor is configured to include a pair of first light detection units 22b and a pair of second light detection units 22c.

**[0027]** The light source 22a irradiates the head with red light and near-infrared light having different wavelengths. One light source 22a is arranged between the first measurement electrode 21c and the reference electrode 21b and the other is arranged between the second measurement electrode 21d and the ground electrode 21a.

**[0028]** The first light detection unit 22b receives the red light and the near-infrared light which are emitted from the light source 22a and are reflected from the head skin or the skull. That is, the first light detection unit 22b receives the light that cannot penetrate into a deep portion of the head and is reflected at a shallow portion of the head such as a head skin or a skull. One of the first light detection unit 22b is arranged between the light source 22a and the reference electrode 21b and the other is arranged between the light source and the ground electrode 21a.

**[0029]** In the case where the red light and the near-infrared light emitted from the light source 22a are reflected from the brain, the second light detection unit 22c receives the light. That is, the second light detection unit 22c receives the light that passes through a shallow portion such as the head skin or a skull, reaches the brain, and is reflected from the brain. Each of a pair of the second light detection units 22c is arranged between the reference electrode 21b and the ground electrode 21a so that the second light detection units 22c are separated from each other.

**[0030]** Since the light sources 22a, first light detection units 22b and the second light detection units 22c are located in the above-described manner, one of the light sources 22a, one of the first light detection units 22b, and one of the second light detection units 22c are arranged in the vicinity of the reference electrode 21b, and the other of the light sources 22a and the other of the first light detection units 22b, and the other of the second light detection units 22c are arranged in the vicinity of the ground electrode 21a. Therefore, when one of the light sources 22a, one of the first light detection units 22b, and one of the second light detection units 22c arranged in the vicinity of the reference electrode 21b measure the oxygen saturation of the left brain, the other of the light sources 22a and the other of the first light detection units

22b, and the other of the second light detection units 22c arranged in the vicinity of the ground electrode 21a measure the oxygen saturation of the right brain.

**[0031]** Meanwhile, the strap 10 may be formed to have wrinkles 10a in a portion where the depth-of-anesthesia sensor 21 and the cerebral oxygen saturation sensor 22 are not arranged. As described above, since the surface of the head of a person is not flat but curved, it is also important to select a flexible material for the strap 10 itself in order to effectively adhere the strap 10 to such a head shape. In addition, it is also necessary to form the strap 10 to have an auxiliary means such as wrinkles 10a so that the flexible strap 10 can be well bended.

**[0032]** In addition, if the width of the portion of the strap 10 where the depth-of-anesthesia sensor 21 and the cerebral oxygen saturation sensor 22 are not arranged is smaller than that of the portion where the depth-of-anesthesia sensor 21 and the cerebral oxygen saturation sensor 22 are arranged, the strap 10 may be well bended. Therefore, the depth-of-anesthesia sensor 21 and the cerebral oxygen saturation sensor 22 can be attached better.

[Reference Numerals]

**[0033]**

10: strap  
 10a: wrinkle  
 20: sensing unit  
 21: depth-of-anesthesia sensor  
 21a: ground electrode  
 21b: reference electrode  
 21c: first measurement electrode  
 21d: second measurement electrode  
 22: cerebral oxygen saturation sensor  
 22a: light source  
 22b: first light detection unit  
 22c: second light detection unit

#### Claims

1. An integrated depth-of-anesthesia/cerebral-oxygen-saturation detection sensor comprising:
  - a strap (10); and
  - a sensing unit (20) arranged on the strap (10), wherein the sensing unit (20) includes a depth-of-anesthesia sensor (21) and a cerebral oxygen saturation sensor (22) that are arranged on the same plane.
2. The integrated depth-of-anesthesia/cerebral-oxygen-saturation detection sensor according to claim 1, wherein the depth-of-anesthesia sensor (21) includes:

a ground electrode (21a);  
 a reference electrode (21b) that is arranged to be separated from the ground electrode (21a);  
 and  
 first and second measurement electrodes (21c and 21d) that are arranged on two sides of the ground electrode (21a) and the reference electrode (21b) so that the ground electrode (21a) and the reference electrode (21b) are located between the ground electrode (21a) and the reference electrode (21b).

- 3. The integrated depth-of-anesthesia/cerebral-oxygen-saturation detection sensor according to claim 2, wherein the cerebral oxygen saturation sensor (22) includes:

a pair of light sources (22a) that irradiate a head with red light and near-infrared light having different wavelengths;  
 a pair of first light detection units (22b) that receive light reflected from head skin or skull; and  
 a pair of second light detection units (22c) that receive light reflected from brain.

- 4. The integrated depth-of-anesthesia/cerebral-oxygen-saturation detection sensor according to claim 3,  
 wherein the pair of light sources (22a) are located between the first measurement electrode (21c) and the reference electrode (21b) and between the second measurement electrode (21d) and the ground electrode (21a),  
 wherein the pair of first light detection units (22b) are located between the light source (22a) and the reference electrode (21b) and between the light source (22a) and the ground electrode (21a), and  
 wherein the pair of second light detection units (22c) are located to be separated from each other between the reference electrode (21b) and the ground electrode (21a).

- 5. The integrated depth-of-anesthesia/cerebral-oxygen-saturation detection sensor according to claim 1,  
 wherein the strap (10) is formed to have wrinkles (10a) in a portion where the depth-of-anesthesia sensor (21) and the cerebral oxygen saturation sensor (22) are not arranged.

5

10

15

20

25

30

35

40

45

50

55

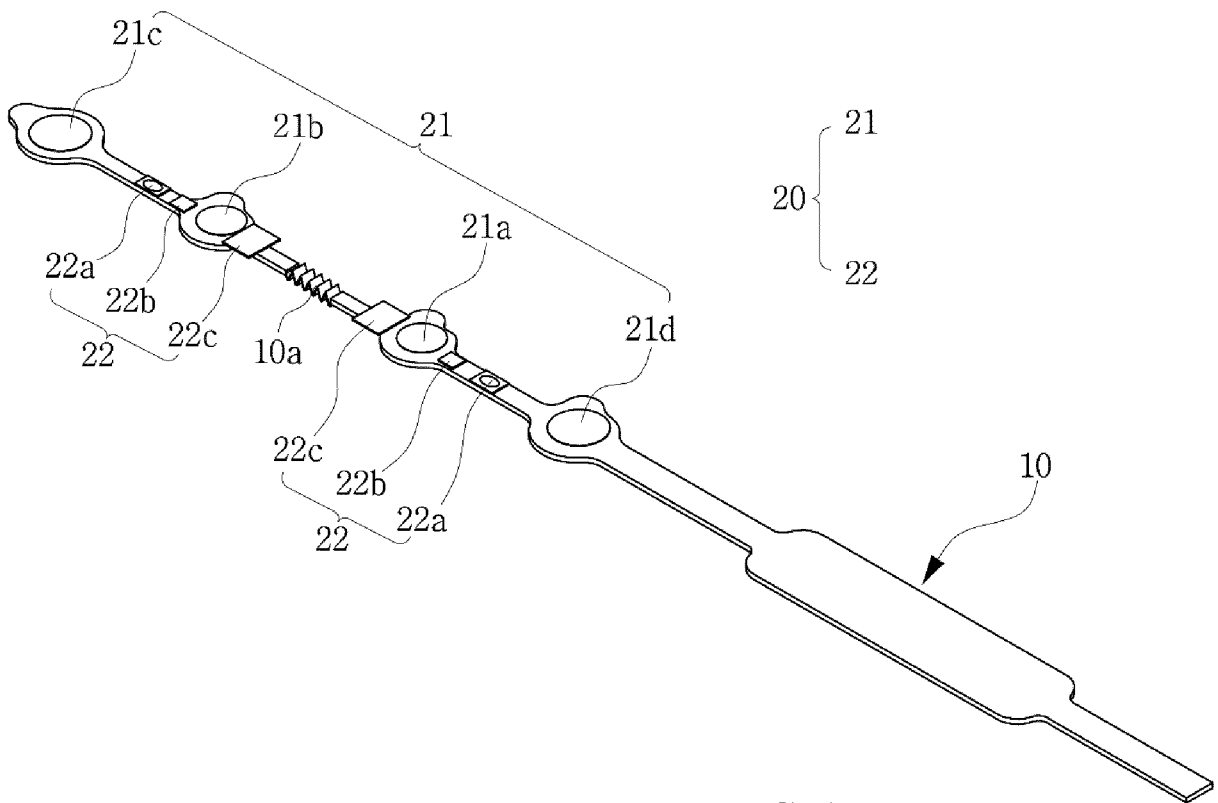

FIG. 1

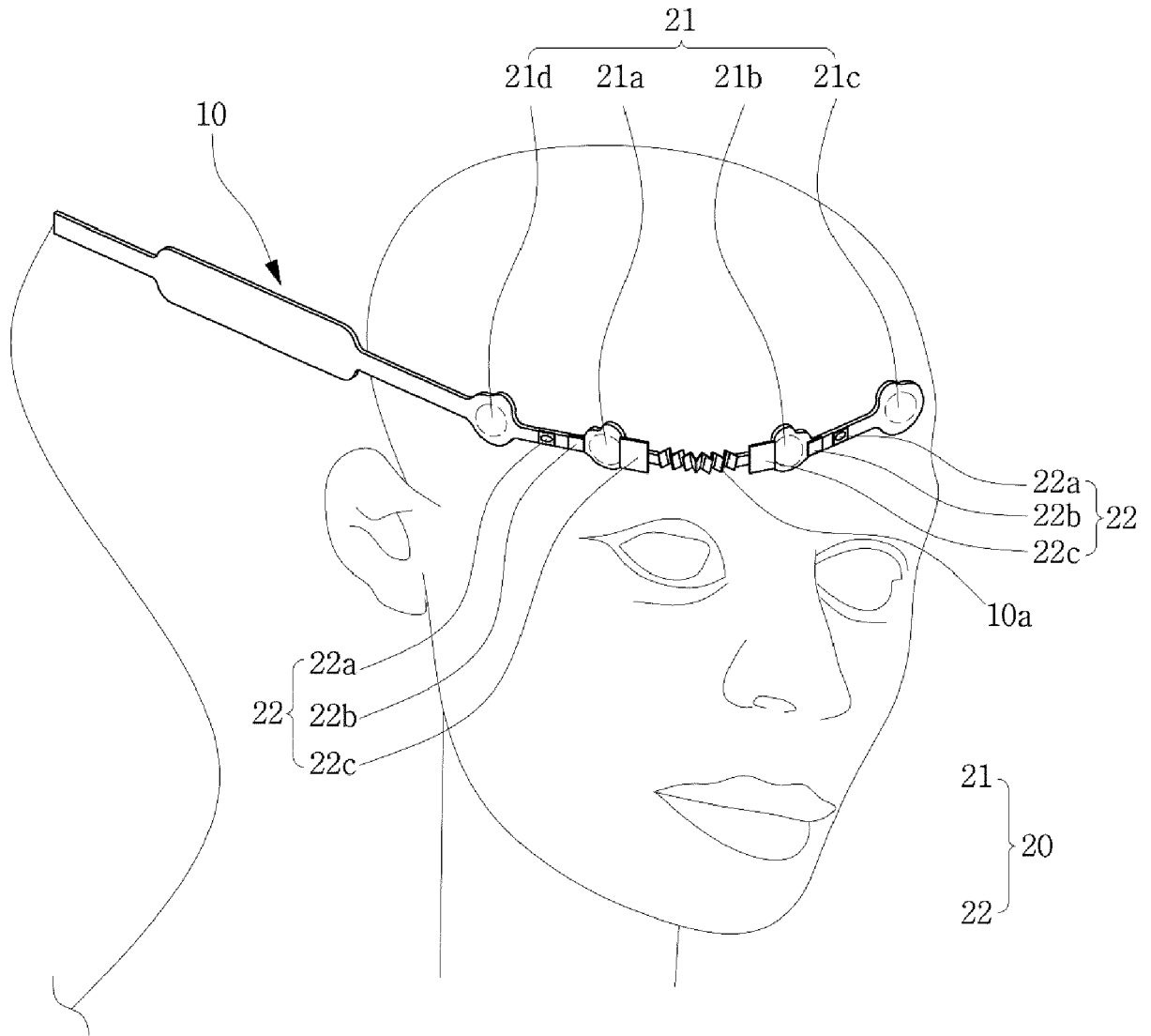

FIG. 2



EUROPEAN SEARCH REPORT

Application Number  
EP 17 20 3241

5

10

15

20

25

30

35

40

45

50

55

DOCUMENTS CONSIDERED TO BE RELEVANT			
Category	Citation of document with indication, where appropriate, of relevant passages	Relevant to claim	CLASSIFICATION OF THE APPLICATION (IPC)
X	US 2012/083673 A1 (AL-ALI AMMAR [US] ET AL) 5 April 2012 (2012-04-05)	1-4	INV. A61B5/1455 A61B5/00 A61B5/0476
Y	* paragraphs [0013], [0077]-[0097], [0106]-[0109], [0112]-[0115]; figure 3 *	5	
Y	----- US 2012/277548 A1 (BURTON DAVID [AU]) 1 November 2012 (2012-11-01) * paragraph [0041]; figure 4 *	5	
X	----- US 2016/095548 A1 (AL-ALI AMMAR [US] ET AL) 7 April 2016 (2016-04-07) * paragraph [0023] - paragraph [0034]; figure 1 *	1-4	
X	----- US 2013/030267 A1 (LISOGURSKI DANIEL [US] ET AL) 31 January 2013 (2013-01-31) * paragraph [0038] - paragraph [0039]; figures 5-9 *	1-3	
A	----- US 2007/208269 A1 (MUMFORD JOHN R [CA] ET AL) 6 September 2007 (2007-09-06) * paragraph [0074] *	1-5	TECHNICAL FIELDS SEARCHED (IPC) A61B
The present search report has been drawn up for all claims			
Place of search The Hague		Date of completion of the search 14 February 2018	Examiner Konstantinou, G
CATEGORY OF CITED DOCUMENTS X : particularly relevant if taken alone Y : particularly relevant if combined with another document of the same category A : technological background O : non-written disclosure P : intermediate document T : theory or principle underlying the invention E : earlier patent document, but published on, or after the filing date D : document cited in the application L : document cited for other reasons & : member of the same patent family, corresponding document			

EPO FORM 1503 03.02 (P04C01)

ANNEX TO THE EUROPEAN SEARCH REPORT  
ON EUROPEAN PATENT APPLICATION NO.

EP 17 20 3241

5

This annex lists the patent family members relating to the patent documents cited in the above-mentioned European search report. The members are as contained in the European Patent Office EDP file on  
The European Patent Office is in no way liable for these particulars which are merely given for the purpose of information.

14-02-2018

10

15

20

25

30

35

40

45

50

55

Patent document cited in search report	Publication date	Patent family member(s)	Publication date
US 2012083673 A1	05-04-2012	EP 2621333 A2	07-08-2013
		JP 5710767 B2	30-04-2015
		JP 2013541990 A	21-11-2013
		US 2012083673 A1	05-04-2012
		US 2014371548 A1	18-12-2014
		US 2017156620 A1	08-06-2017
		WO 2012050847 A2	19-04-2012
US 2012277548 A1	01-11-2012	AU 2010282150 A1	26-07-2012
		AU 2016202435 A1	23-06-2016
		CN 102946797 A	27-02-2013
		CN 107095656 A	29-08-2017
		EP 2464283 A1	20-06-2012
		JP 5754054 B2	22-07-2015
		JP 2013501542 A	17-01-2013
		KR 20120049337 A	16-05-2012
		KR 20160050092 A	10-05-2016
		US 2012277548 A1	01-11-2012
WO 2011017778 A1	17-02-2011		
US 2016095548 A1	07-04-2016	US 2016095548 A1	07-04-2016
		WO 2016057553 A1	14-04-2016
US 2013030267 A1	31-01-2013	NONE	
US 2007208269 A1	06-09-2007	NONE	

EPO FORM P0459

For more details about this annex : see Official Journal of the European Patent Office, No. 12/82

**REFERENCES CITED IN THE DESCRIPTION**

*This list of references cited by the applicant is for the reader's convenience only. It does not form part of the European patent document. Even though great care has been taken in compiling the references, errors or omissions cannot be excluded and the EPO disclaims all liability in this regard.*

**Patent documents cited in the description**

- KR 1020100035977 [0006]
- KR 101079785 [0006]

专利名称(译)	传感器用于麻醉深度和脑血氧饱和度		
公开(公告)号	<a href="#">EP3326530A1</a>	公开(公告)日	2018-05-30
申请号	EP2017203241	申请日	2017-11-23
[标]申请(专利权)人(译)	灿美工程股份有限公司		
申请(专利权)人(译)	CHARM ENGINEERING CO. , LTD.		
当前申请(专利权)人(译)	CHARM ENGINEERING CO. , LTD.		
[标]发明人	KIM KWANG MOO HONG SEUNG KYUN CHOI SANG WOO LEE KYU HONG		
发明人	KIM, KWANG MOO HONG, SEUNG KYUN CHOI, SANG WOO LEE, KYU HONG		
IPC分类号	A61B5/1455 A61B5/00 A61B5/0476		
CPC分类号	A61B5/4821 A61B5/0476 A61B5/14552 A61B5/14553 A61B5/6814 A61B5/6831 A61B5/6832		
优先权	1020160158908 2016-11-28 KR		
外部链接	<a href="#">Espacenet</a>		

摘要(译)

提供了一个完整的麻醉深度/脑氧饱和度检测传感器。特别地，麻醉深度/脑氧饱和度检测传感器包括带子和布置在带子上的感测单元，并且感测单元包括布置有麻醉深度传感器和脑氧饱和度传感器，在同一架飞机上。因此，可以用一个检测传感器同时测量麻醉深度和脑血氧饱和度，从而可以降低成本。

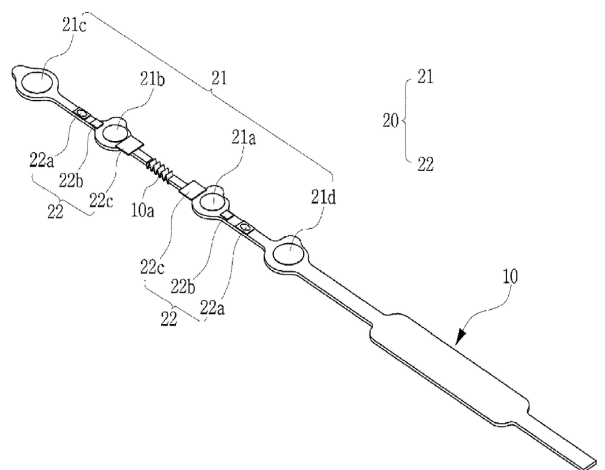

FIG. 1